



US00D439356S

(12) **United States Design Patent**
Martinson et al.

(10) **Patent No.:** **US D439,356 S**

(45) **Date of Patent:** **** Mar. 20, 2001**

(54) **LIGHTING INSTRUMENT**

(75) Inventors: **Timothy S. Martinson**, Arlington;
Travis J. Reinert, Rowlett; **Breck M. Outland**, Dallas; **Vincent W. Brown**, Addison, all of TX (US)

(73) Assignee: **Vari-Lite, Inc.**, Dallas, TX (US)

(**) Term: **14 Years**

(21) Appl. No.: **29/112,443**

(22) Filed: **Oct. 15, 1999**

(51) **LOC (7) Cl.** **26-05**

(52) **U.S. Cl.** **D26/63**

(58) **Field of Search** D26/60-66; 362/267,
362/269, 271, 272, 282, 287, 418, 419,
427

(56) **References Cited**

U.S. PATENT DOCUMENTS

D. 324,431	*	3/1992	Richardson et al.	D26/63
D. 372,550	*	8/1996	Stultz	D26/63
D. 413,995	*	9/1999	Lee et al.	D26/63

* cited by examiner

Primary Examiner—Susan J. Lucas

(74) *Attorney, Agent, or Firm*—Carr & Storm, L.L.P.

(57) **CLAIM**

We claim the ornamental design for a lighting instrument, as shown and described.

DESCRIPTION

The nature of the lighting instrument is such that it includes a lamp housing having a clear lens at one end thereof

through which a beam of light is projected, a yoke assembly supporting the lamp housing, and a generally rectangular enclosure supporting the yoke assembly. The lighting instrument is intended for use in entertainment lighting applications, such as stage lighting and the like, and is intended to be used in a manner that includes dynamic repositioning of the lamp housing with respect to the yoke assembly and/or dynamic repositioning of the yoke assembly with respect to the generally rectangular enclosure. The lighting instrument may be used in any orientation but, for convenience, is shown resting upon the generally rectangular enclosure, although the lighting instrument may also be used more frequently in an inverted orientation by attaching support hooks or clamps to the generally rectangular enclosure.

FIG. 1 is a side view of a lighting instrument;

FIG. 2 is a front view thereof;

FIG. 3 is another side view thereof;

FIG. 4 is a rear view thereof;

FIG. 5 is a top view thereof;

FIG. 6 is a bottom view thereof;

FIG. 7 is a perspective view (in an inverted orientation) showing the front, bottom, and side thereof;

FIG. 8 is a perspective view (in an inverted orientation) showing the rear, bottom, and side thereof;

FIG. 9 is a perspective view showing the front, top, and side thereof; and,

FIG. 10 is a perspective view showing the rear, top, and side thereof.

1 Claim, 5 Drawing Sheets

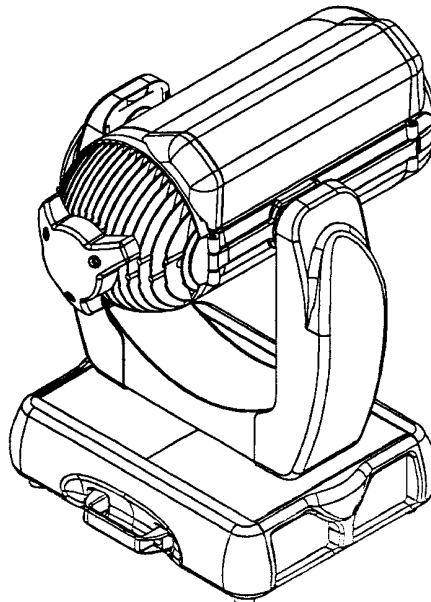
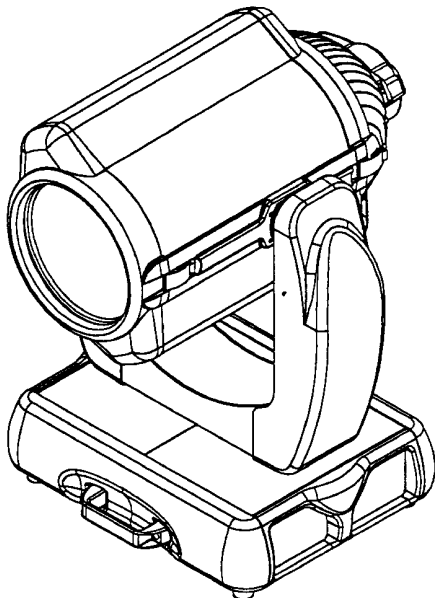

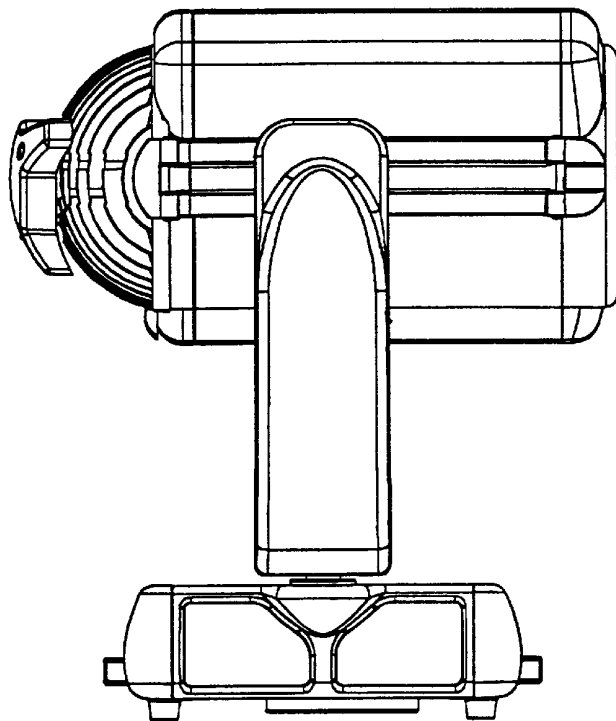

FIG. 1

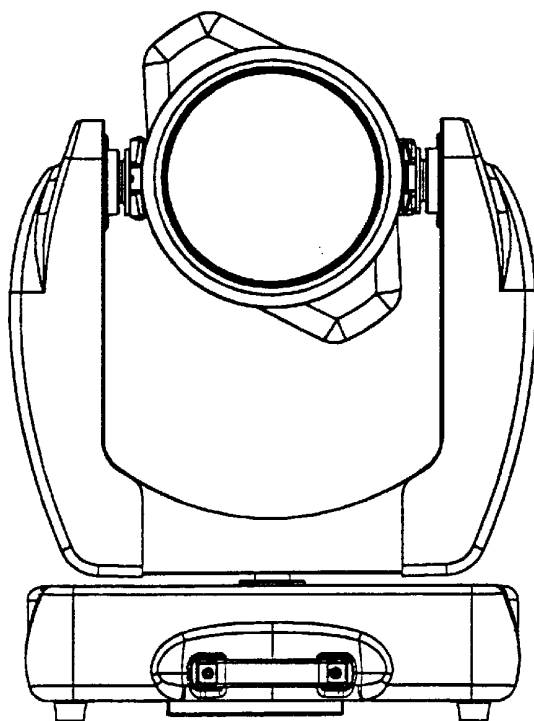

FIG. 2

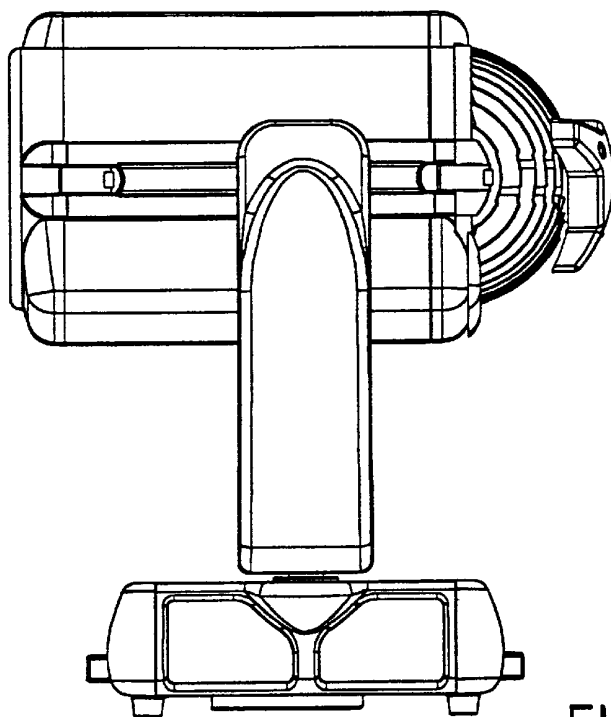

FIG.3

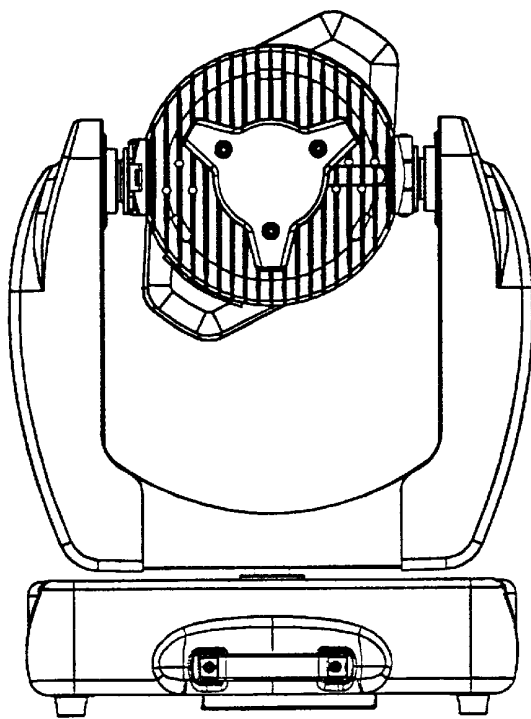

FIG.4

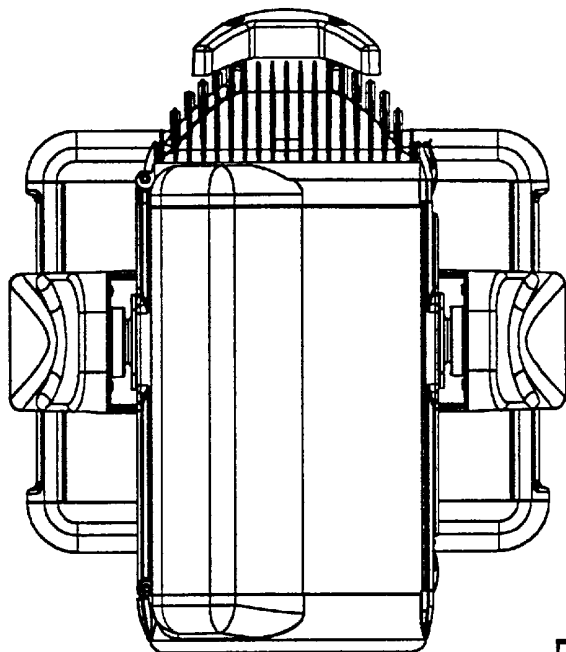

FIG. 5

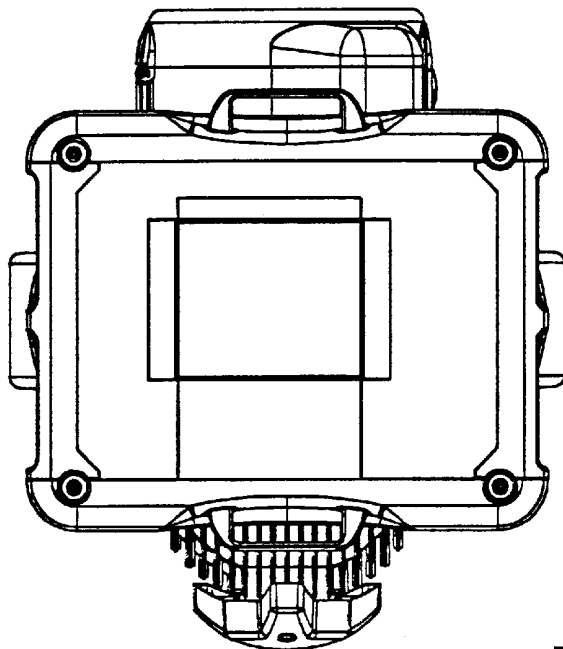

FIG. 6

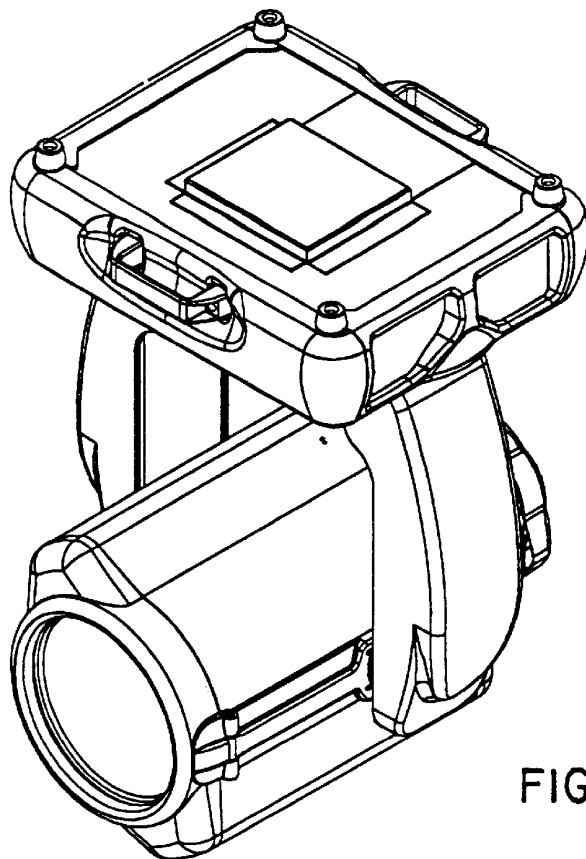

FIG. 7

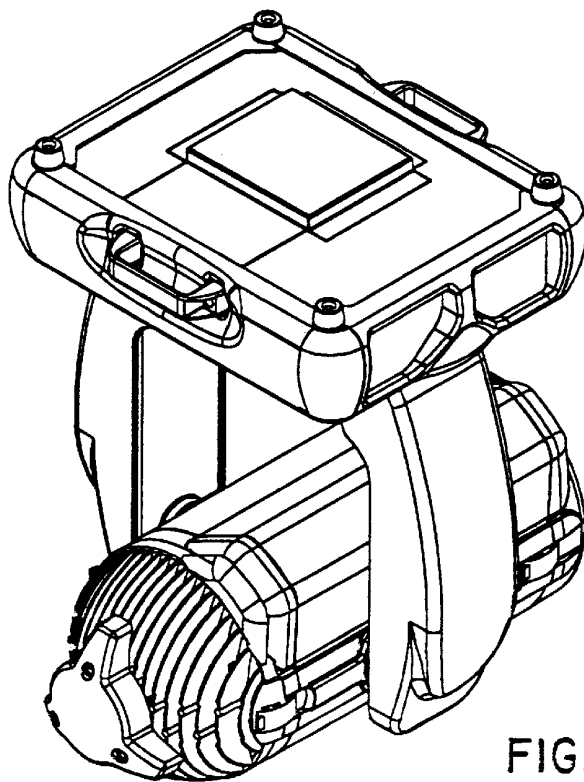

FIG. 8

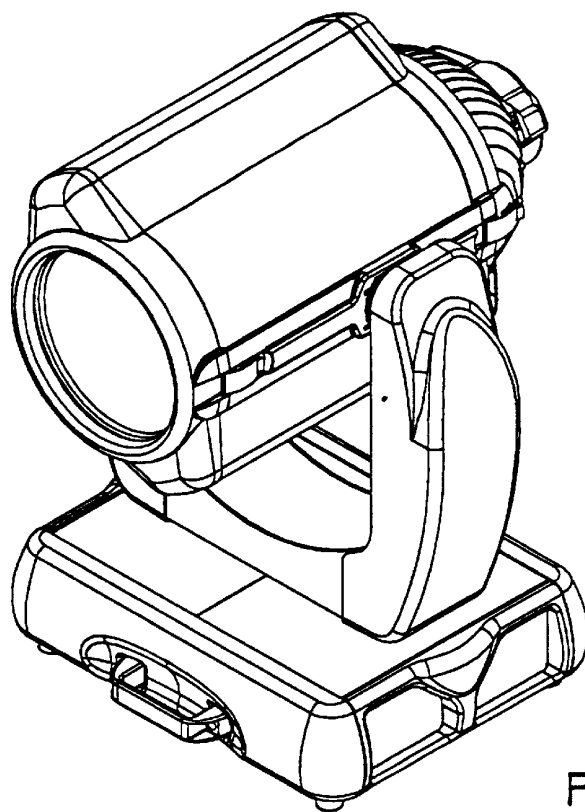

FIG. 9

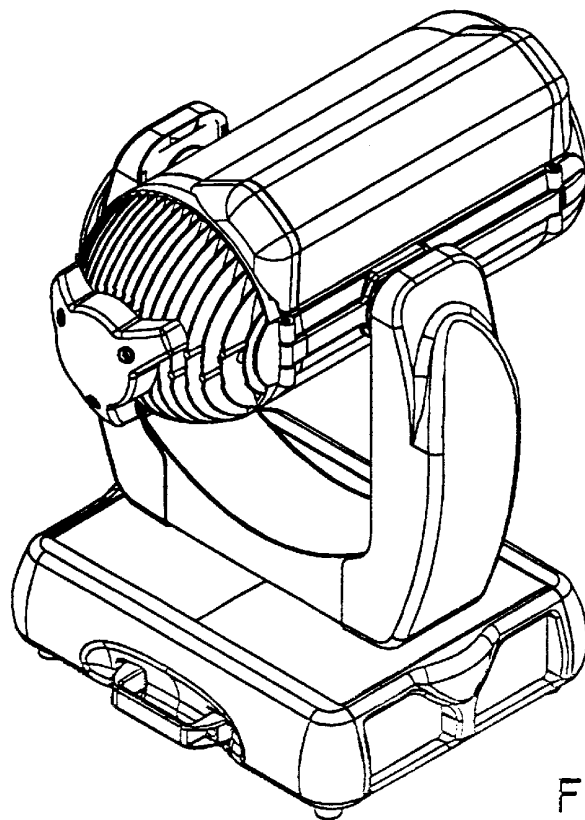

FIG. 10