



US00D415301S

United States Patent [19]
Stacy et al.

[11] **Patent Number: Des. 415,301**
[45] **Date of Patent: ** Oct. 12, 1999**

[54] **ADJUSTABLE COMPACT LUMINAIRE**

[75] Inventors: **Timothy D. Stacy**, Plano; **Douglas A. Hanson**, Arlington; **Timothy W. Terleski**, Garland, all of Tex.

[73] Assignee: **Vari-Lite, Inc.**, Dallas, Tex.

[**] Term: **14 Years**

[21] Appl. No.: **29/046,482**

[22] Filed: **Nov. 16, 1995**

[51] **LOC (6) Cl.** **26-05**

[52] **U.S. Cl.** **D26/63**

[58] **Field of Search** D26/60, 61, 63;
362/269, 277, 285, 287, 418, 419, 427,
281, 284, 283

[56] **References Cited**

U.S. PATENT DOCUMENTS

D. 326,331	5/1992	Riccadelli	D26/63
D. 370,075	5/1996	Mier-Langner et al.	D26/63
5,295,056	3/1994	Peck	362/267

Primary Examiner—Susan J. Lucas
Attorney, Agent, or Firm—Hughes & Luce, L.L.P.

[57] **CLAIM**

We claim the ornamental design for an adjustable compact luminaire, as shown and described.

DESCRIPTION

FIG. 1 is a perspective view of the ornamental appearance of the adjustable compact luminaire of the present invention. FIG. 2 is a front view of the adjustable compact luminaire shown in FIG. 1. FIG. 3 is a rear view of the adjustable compact luminaire shown in FIG. 1. FIG. 4 is a side view of the adjustable compact luminaire shown in FIG. 1. FIG. 5 is another side view of the adjustable compact luminaire shown in FIG. 1. FIG. 6 is a top view of the adjustable compact luminaire shown in FIG. 1; and, FIG. 7 is a bottom view of the adjustable compact luminaire shown in FIG. 1.

1 Claim, 7 Drawing Sheets

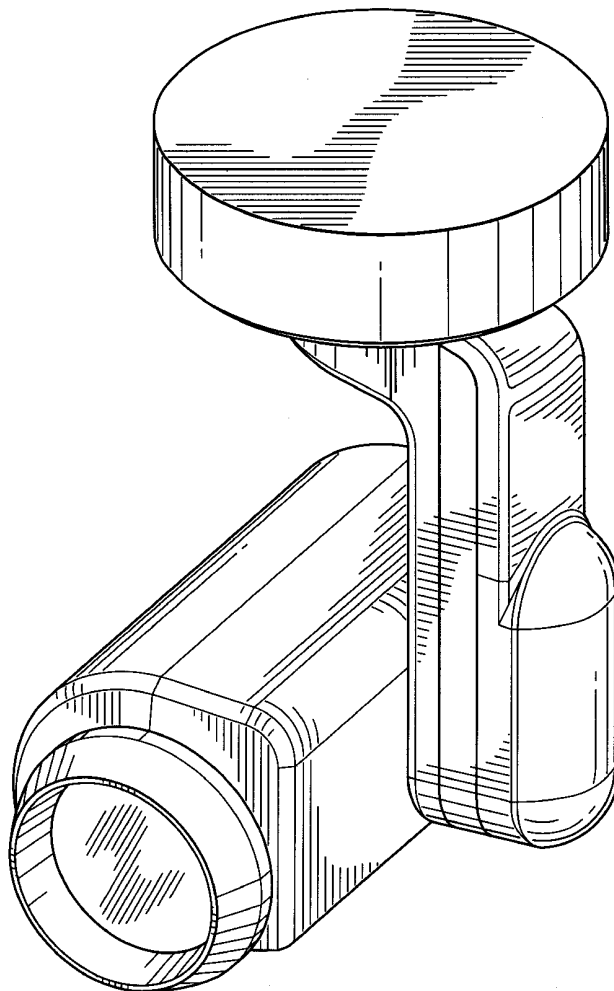

FIG. 1

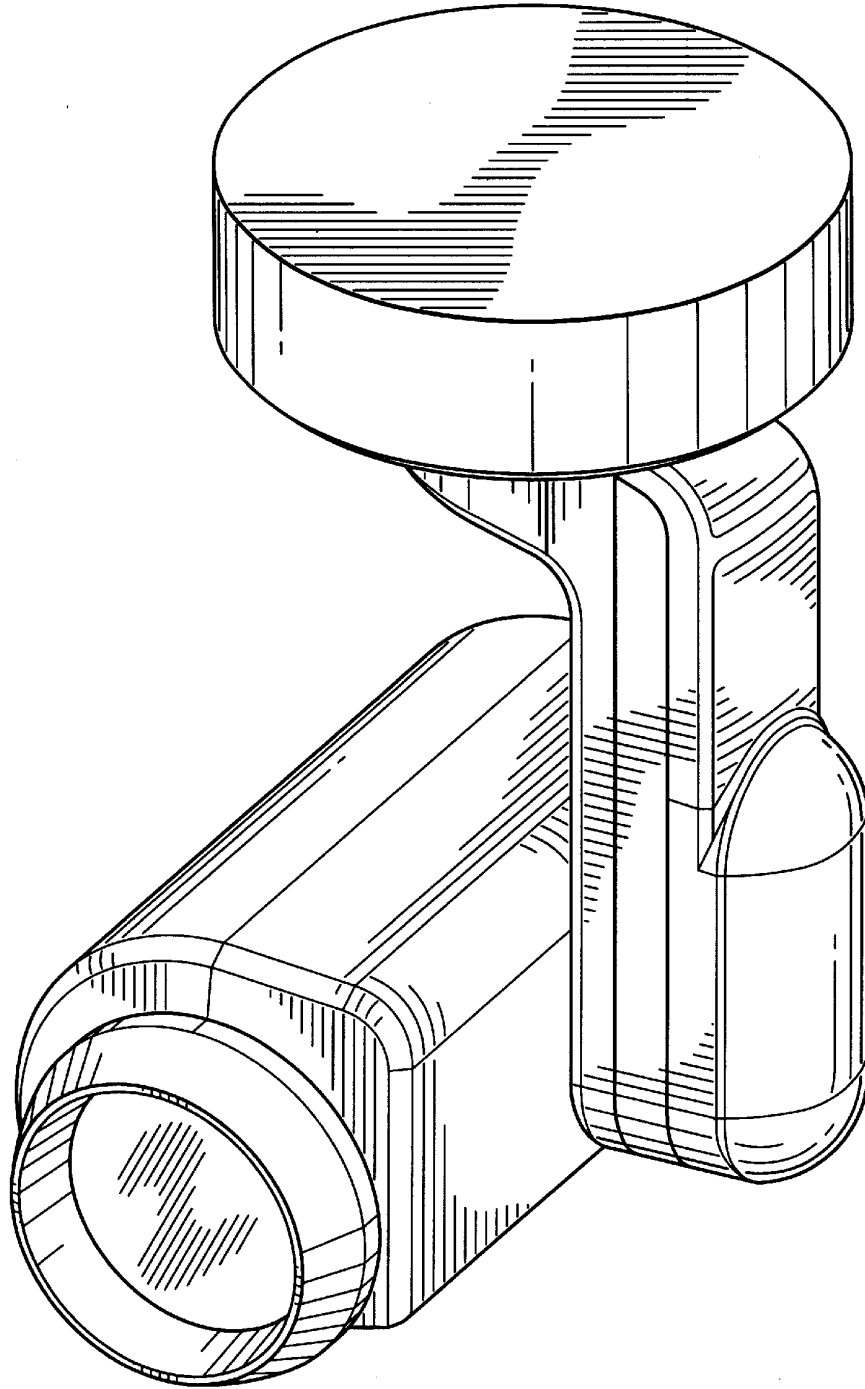

FIG. 2

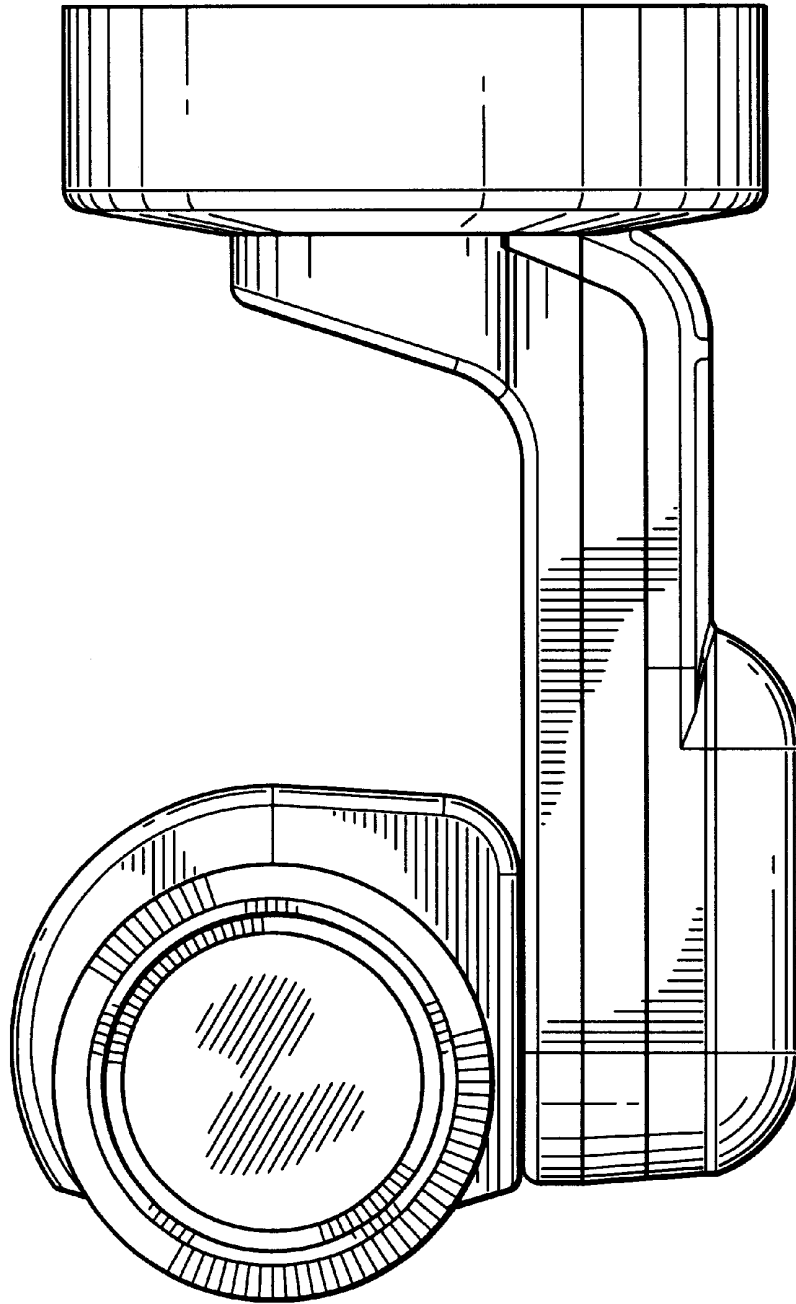

FIG. 3

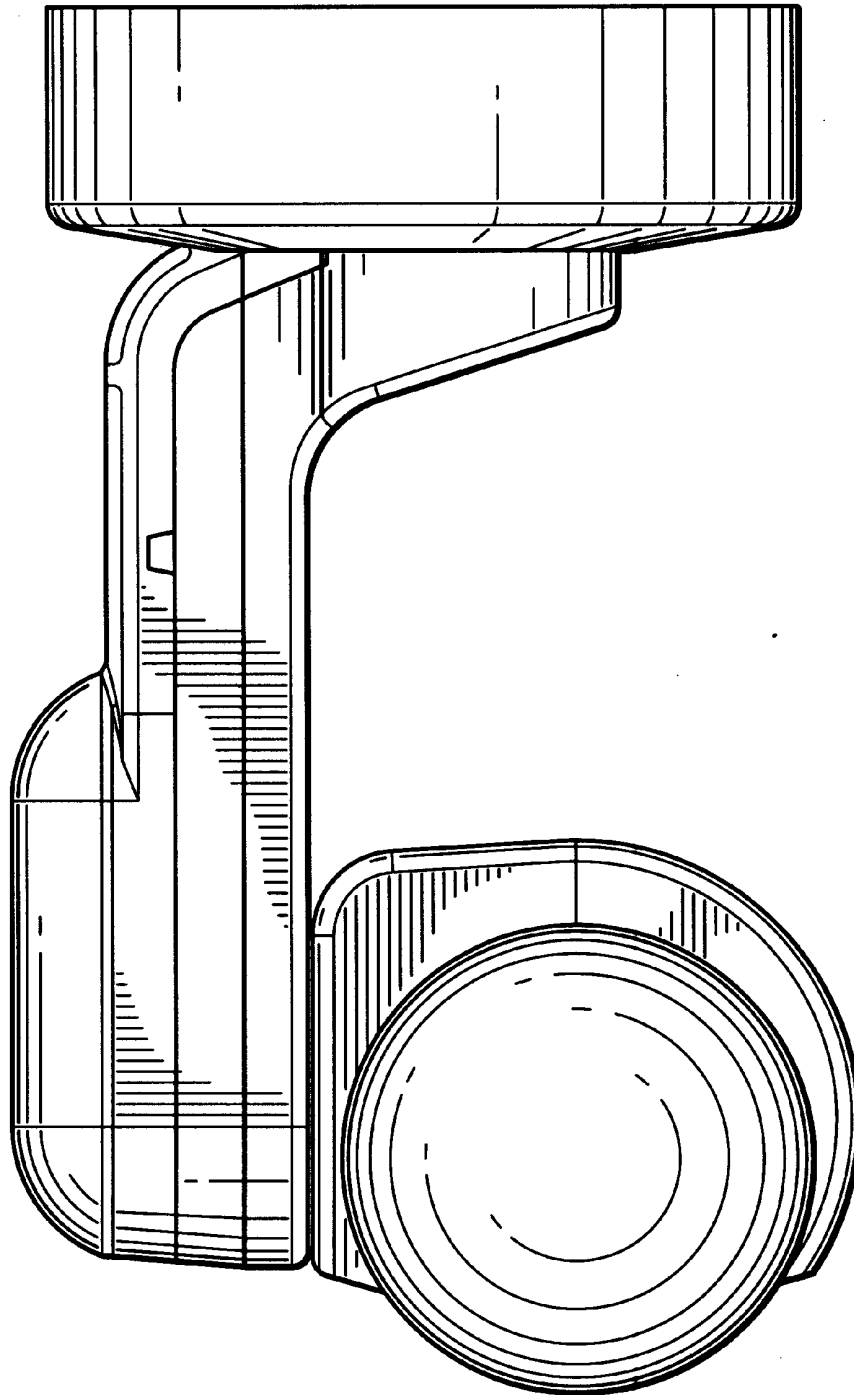

FIG. 4

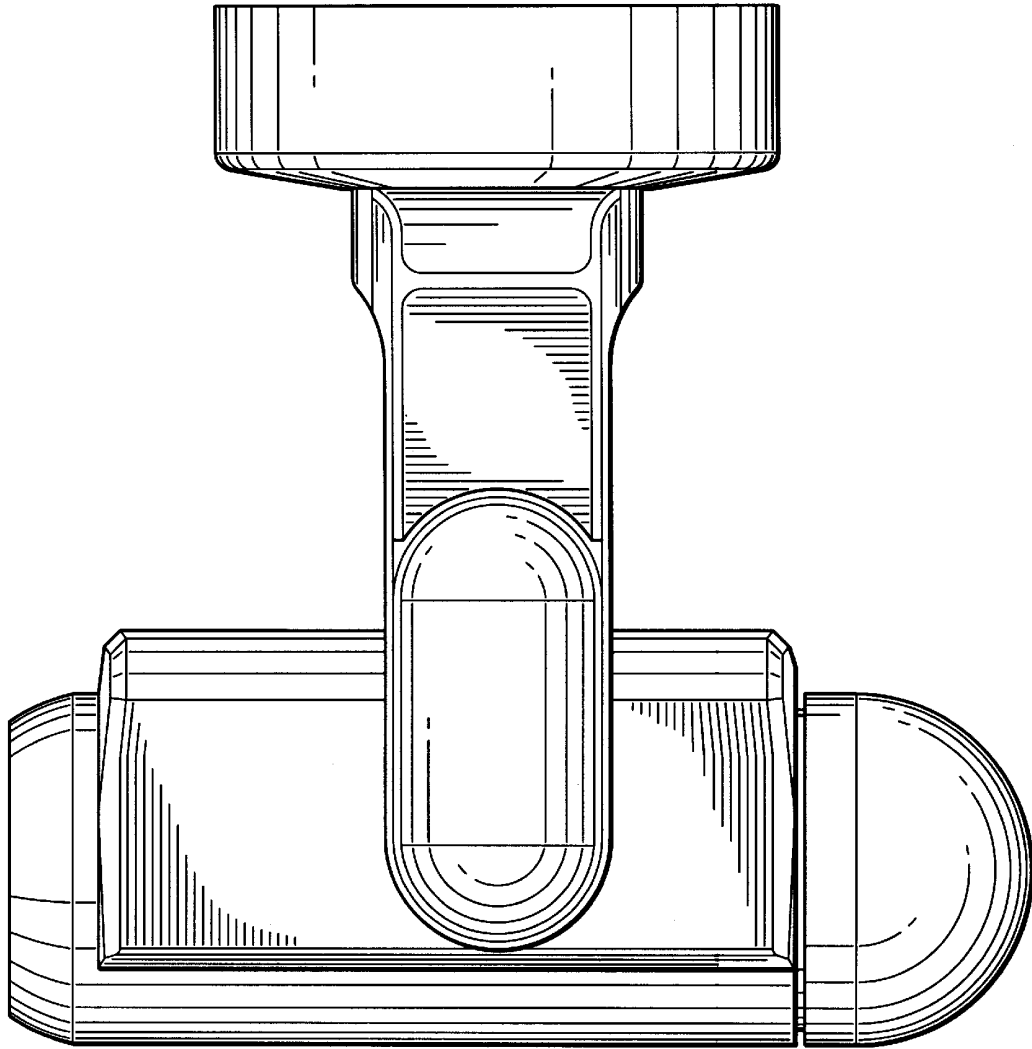

FIG. 5

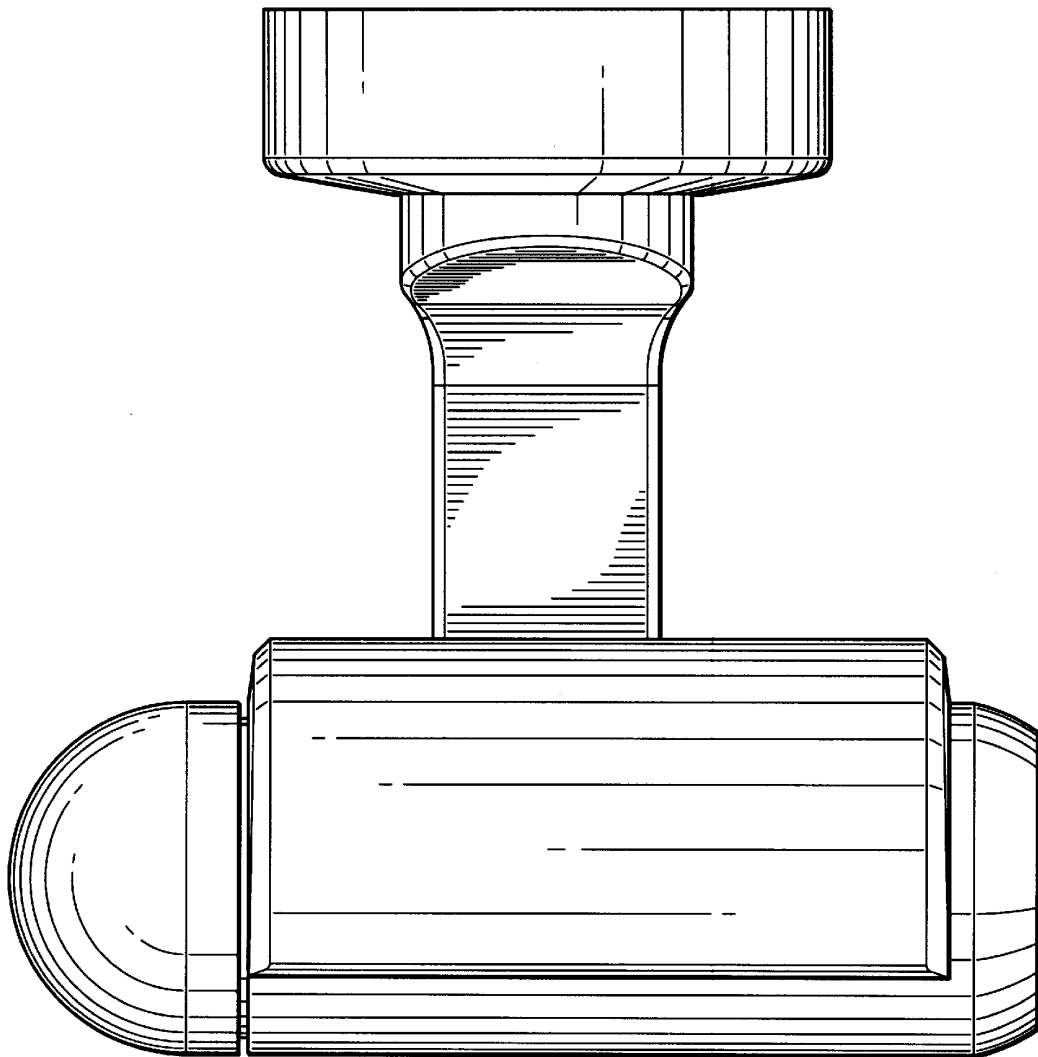

FIG. 6

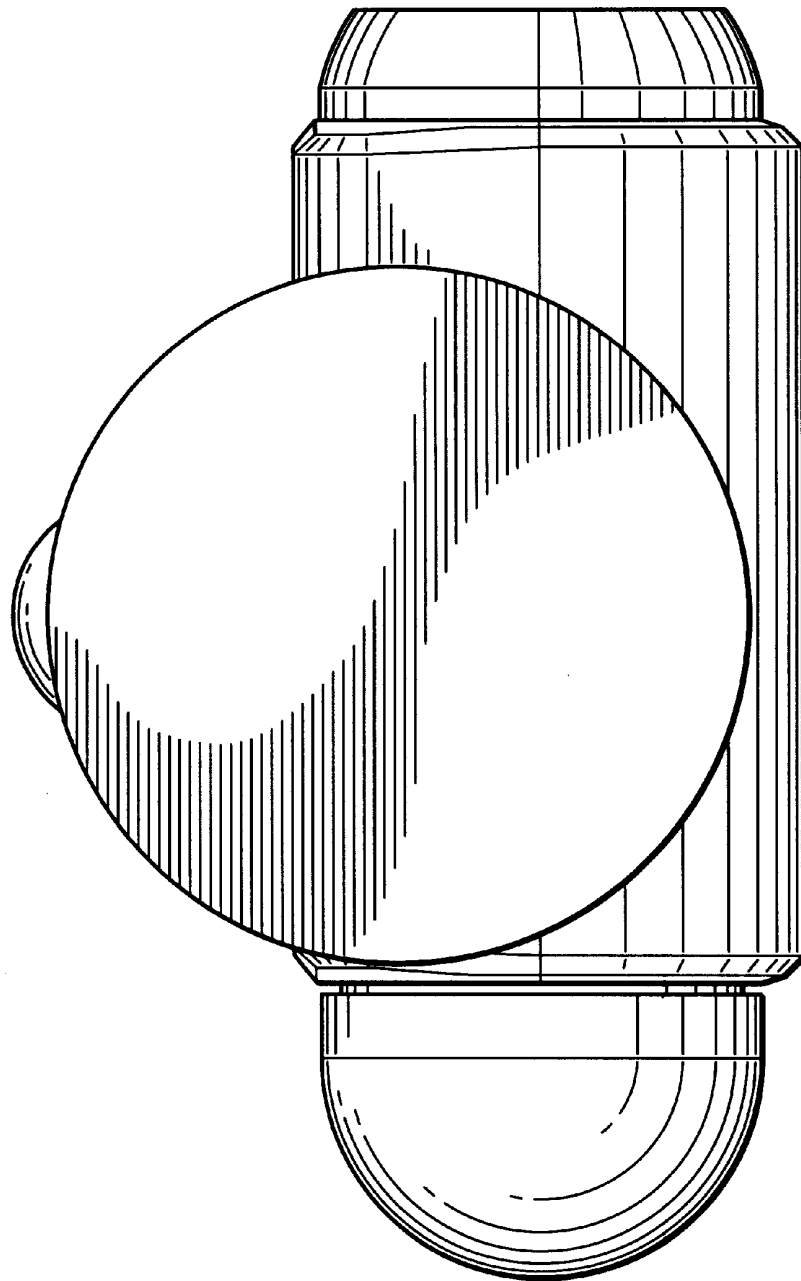

FIG. 7

