



US009502866B1

(12) **United States Patent**  
**Liposky**

(10) **Patent No.:** **US 9,502,866 B1**  
(45) **Date of Patent:** **Nov. 22, 2016**

(54) **CONFIGURABLE MODULAR POWER CONTROL SYSTEM**

174/50, 520, 522, 526; 307/18, 42, 43, 147,  
307/149; 315/112, 114, 115, 291, 312;  
312/223.1, 223.2, 236

(71) Applicant: **Lex Products Corporation**, Shelton, CT (US)

See application file for complete search history.

(72) Inventor: **Joshua Liposky**, Seymour, CT (US)

(56) **References Cited**

(\*) Notice: Subject to any disclaimer, the term of this patent is extended or adjusted under 35 U.S.C. 154(b) by 0 days.

U.S. PATENT DOCUMENTS

(21) Appl. No.: **14/541,615**

(22) Filed: **Nov. 14, 2014**

4,024,441	A *	5/1977	Coyle	.....	H02B 1/36
					174/129 B
4,180,845	A *	12/1979	Shariff	.....	H02B 1/21
					174/133 B
4,528,614	A *	7/1985	Shariff	.....	H02B 1/36
					165/104.33
4,768,967	A *	9/1988	Fritsch	.....	H02B 1/36
					439/152
6,002,563	A	12/1999	Esakoff		
6,270,239	B1	8/2001	Sund		
6,628,089	B2	9/2003	Suomi		
D482,662	S	11/2003	Foster et al.		

**Related U.S. Application Data**

(63) Continuation-in-part of application No. 14/057,430, filed on Oct. 18, 2013, now Pat. No. 9,172,220.

(60) Provisional application No. 62/079,620, filed on Nov. 14, 2014, provisional application No. 61/715,358, filed on Oct. 18, 2012.

(Continued)

*Primary Examiner* — Michail V Datskovskiy

(74) *Attorney, Agent, or Firm* — Steven M. McHugh

(51) **Int. Cl.**  
**H02B 1/48** (2006.01)  
**H02B 1/56** (2006.01)  
**H02B 1/20** (2006.01)  
**H02B 1/36** (2006.01)

(57) **ABSTRACT**

A modular power control system is provided and includes an enclosure having an enclosure top, an enclosure bottom, an enclosure front, an enclosure rear, a first enclosure side and a second enclosure side, wherein the enclosure includes an input power connector. The MPCS further includes a module internal support, wherein the module internal support includes a first and module support connected to the enclosure sides, wherein the first module support includes a first module channel and the second module support includes a second module channel. The MPCS further includes at least one module, wherein the at least one module having module sides which define a module cavity, wherein the module sides include a side channel guide for interacting with the first and second module channels, wherein the module includes at least one module power connector configured to conductively associate with the input power connector.

(52) **U.S. Cl.**  
CPC **H02B 1/48** (2013.01); **H02B 1/20** (2013.01);  
**H02B 1/56** (2013.01)

(58) **Field of Classification Search**  
CPC .... H05K 7/20; H05K 7/1432; H05K 7/1457;  
H05K 7/20572; H05K 5/00; H02M 7/003;  
H02B 1/565; H02B 1/04; G06F 1/16; G06F  
1/20  
USPC ..... 361/601, 605, 611, 614, 622, 624, 627,  
361/641, 644, 631, 657, 679.46-679.5,  
361/690-695, 715, 728, 730, 87, 93.1, 93.9,  
361/103; 165/104.33, 185, 121-126;  
363/161, 144; 174/17 R, 17 VA, 17 CT,

**19 Claims, 58 Drawing Sheets**

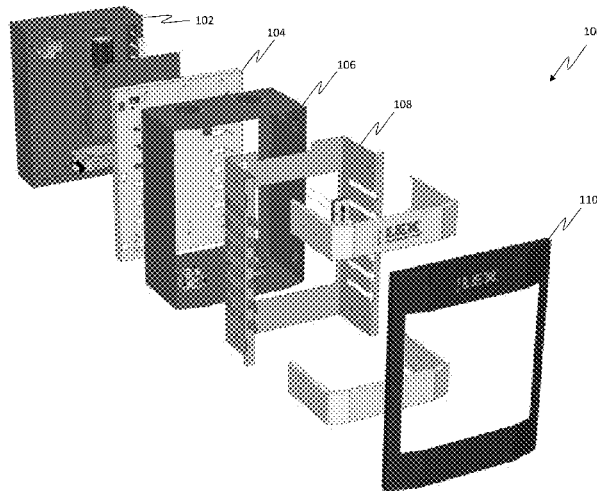

(56)

**References Cited**

U.S. PATENT DOCUMENTS

6,707,256 B2	3/2004	Brunker et al.	7,701,686 B2	4/2010	Kato et al.	
6,849,943 B2	2/2005	Thurk et al.	7,839,391 B2	11/2010	Varian et al.	
7,019,469 B1	3/2006	Thurk et al.	7,839,623 B2	11/2010	Coffey et al.	
7,233,112 B2	6/2007	Burke et al.	7,855,518 B2	12/2010	Xu	
7,304,834 B2	12/2007	Schomaker et al.	7,872,423 B2	1/2011	Biery et al.	
7,358,463 B2	4/2008	Mizuno et al.	8,040,651 B2	10/2011	Deml	
7,369,386 B2	5/2008	Rasmussen et al.	2002/0021548 A1*	2/2002	Muse .....	H02B 1/14 361/641
7,382,595 B2	6/2008	Thurk et al.	2003/0234619 A1	12/2003	Brunker	
7,405,923 B2	7/2008	Kelly et al.	2004/0246662 A1	12/2004	Thurk	
7,440,262 B2	10/2008	Coffey et al.	2005/0052152 A1	3/2005	Suomi et al.	
7,606,014 B2*	10/2009	Ziegler .....	2005/0052872 A1	3/2005	de Peralta	
		H01R 13/6666	2005/0185353 A1	8/2005	Rasmussen	
		361/115	2006/0267515 A1	11/2006	Burke et al.	
7,688,572 B2*	3/2010	Yee .....	2006/0268484 A1	11/2006	Thurk et al.	
		H02B 1/36				
		200/50.08				

\* cited by examiner

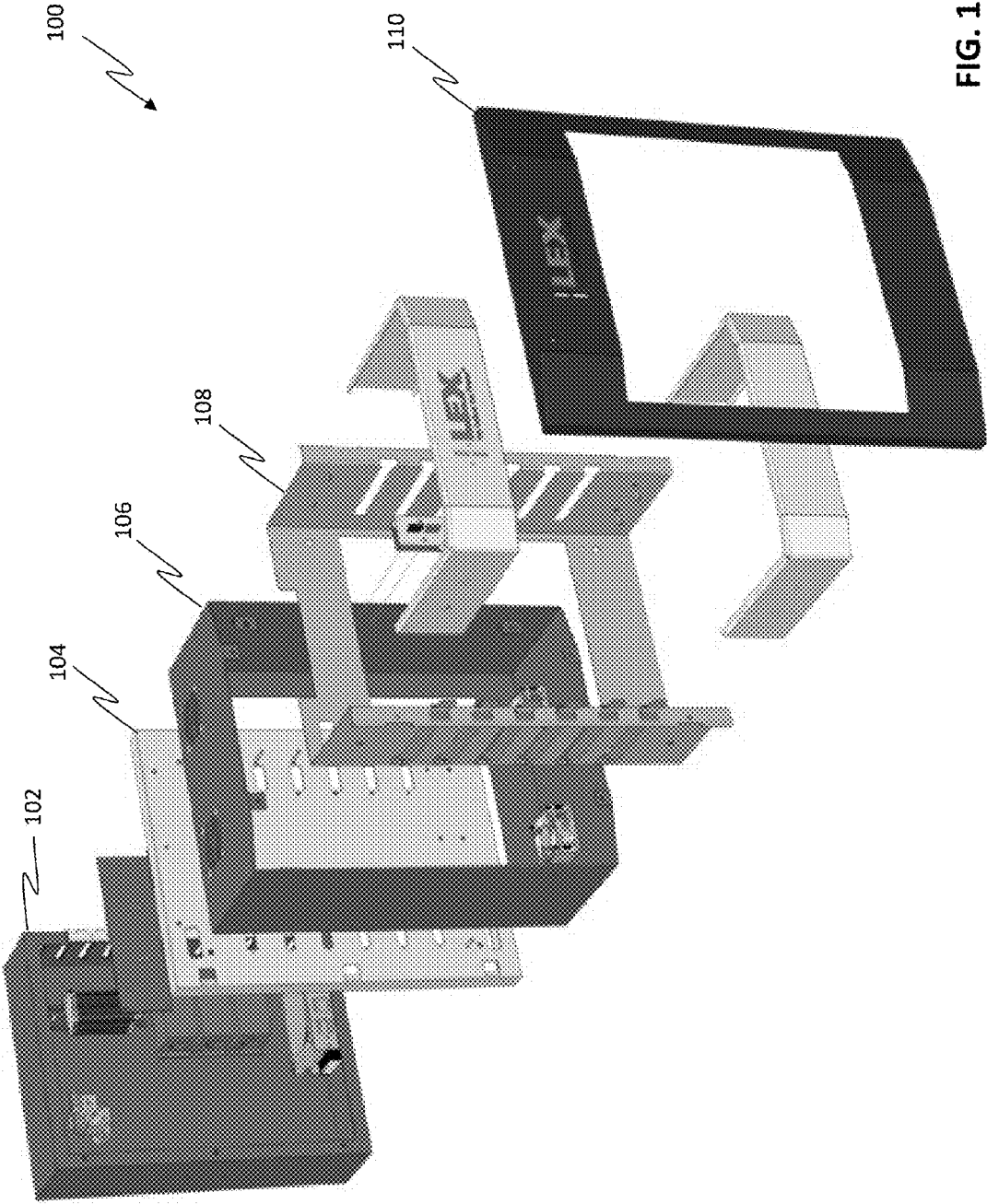

FIG. 1

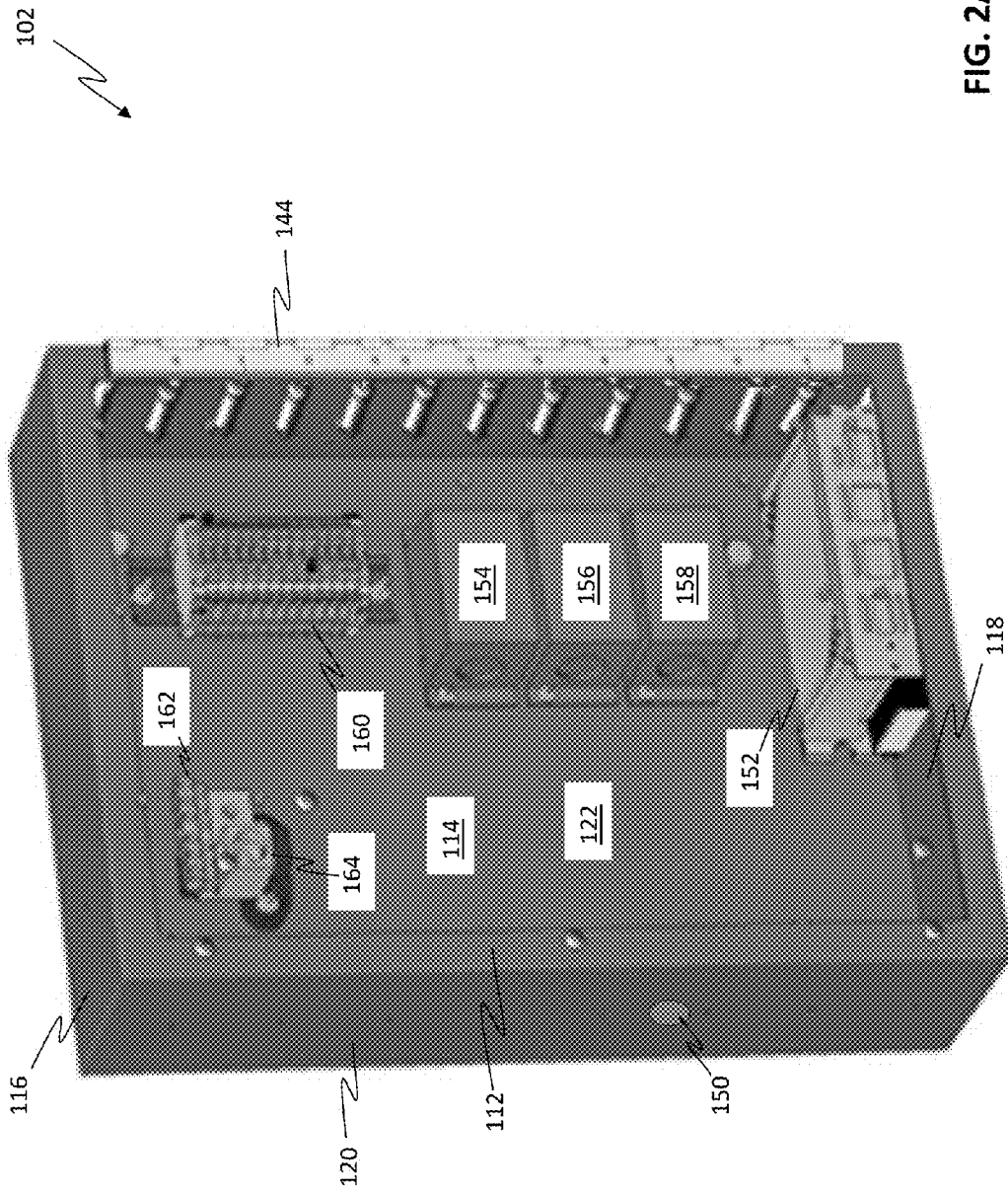

FIG. 2A

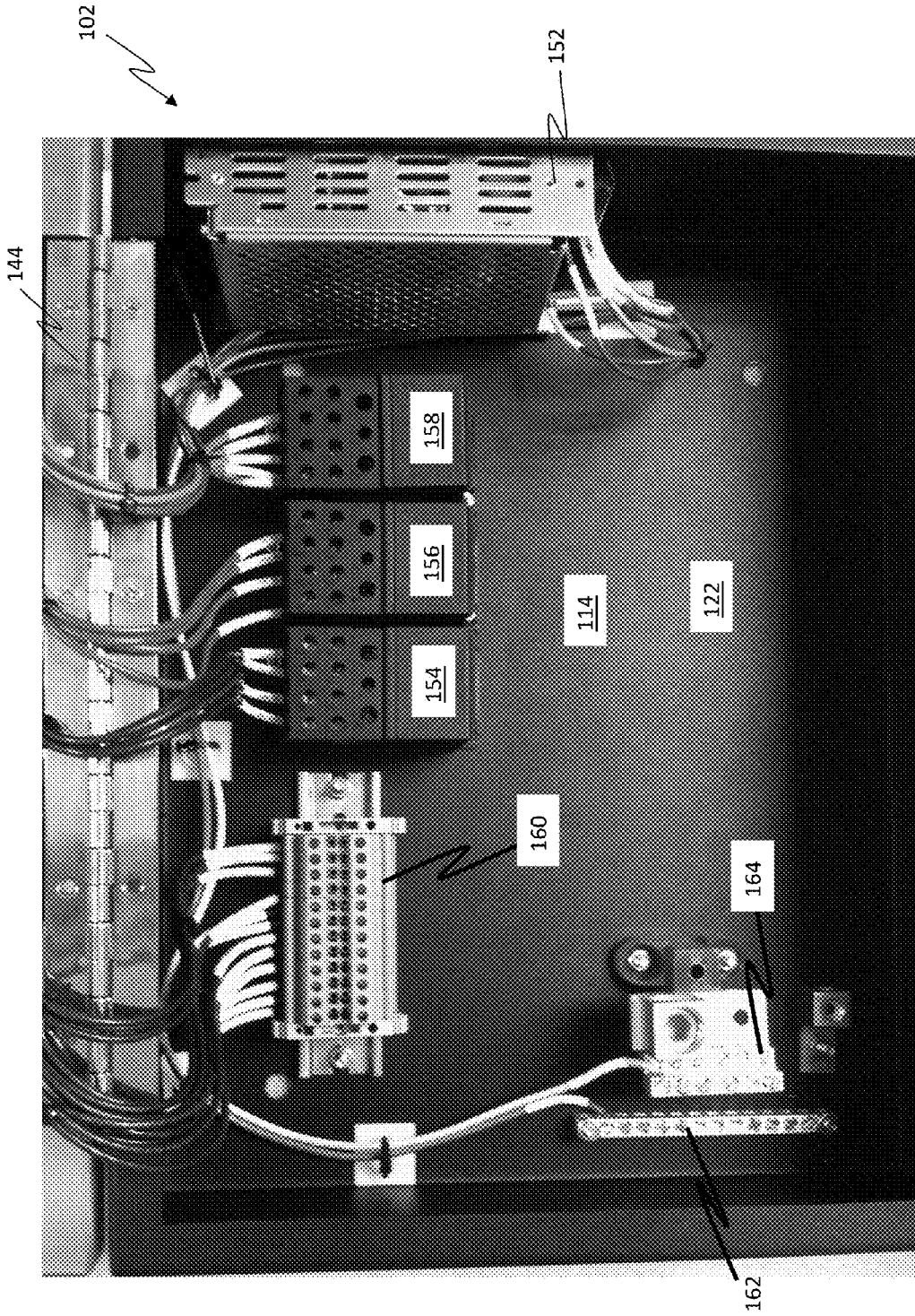

FIG. 2B

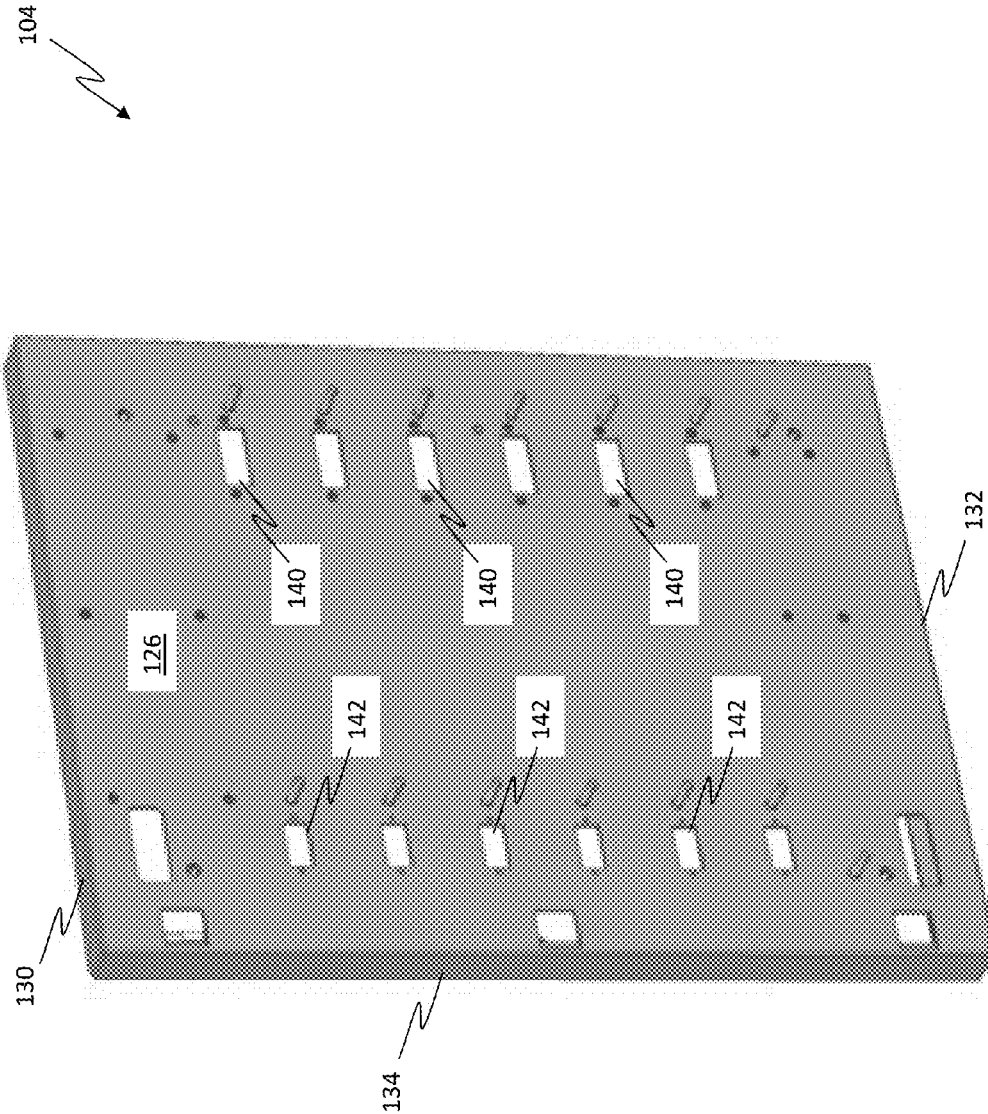

FIG. 3A

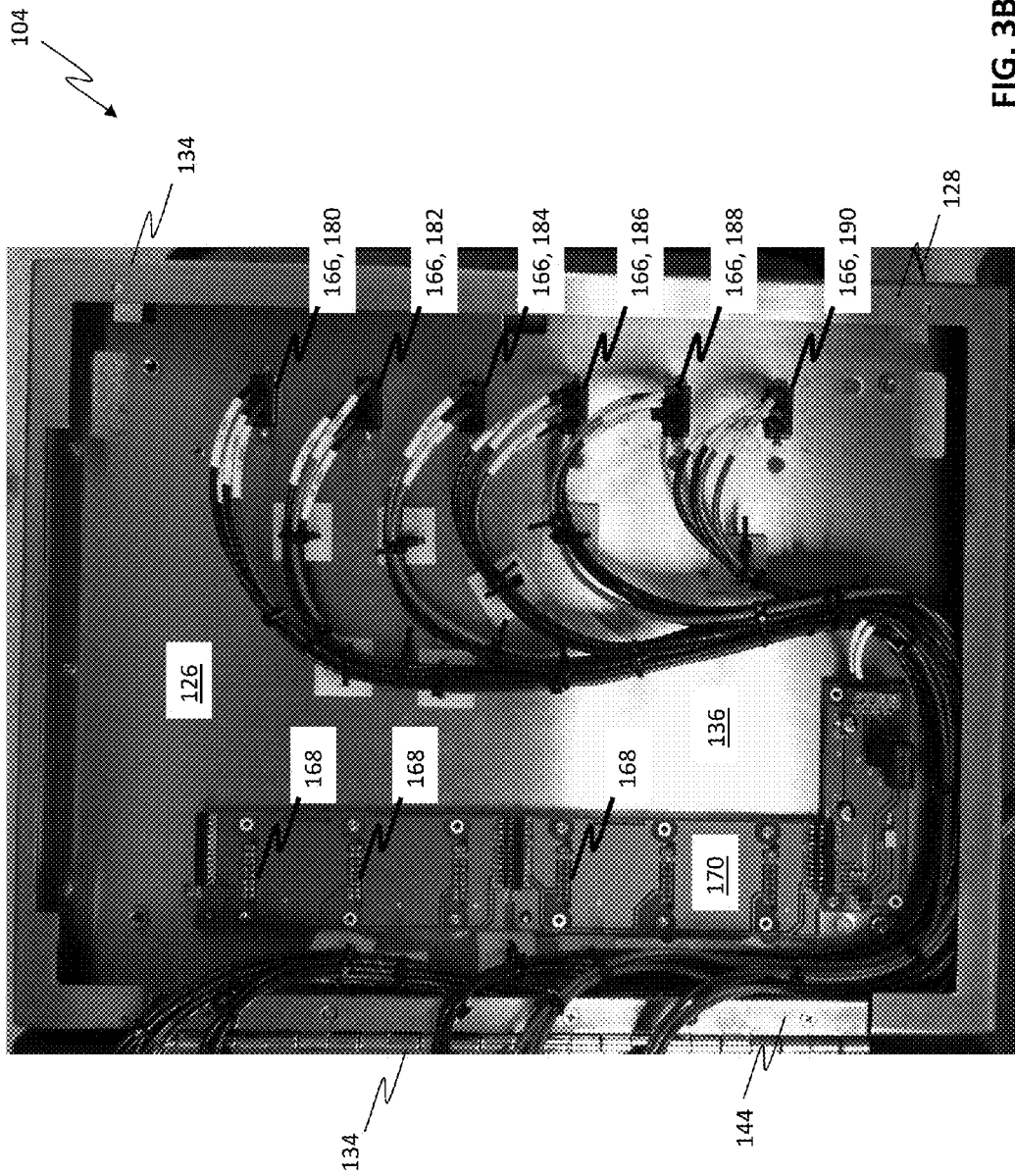

FIG. 3B

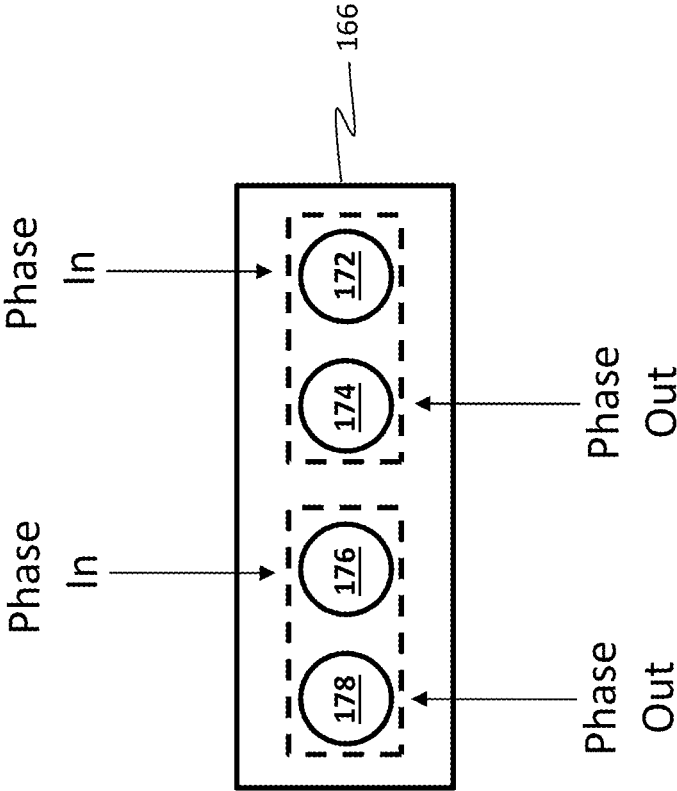

FIG. 4A

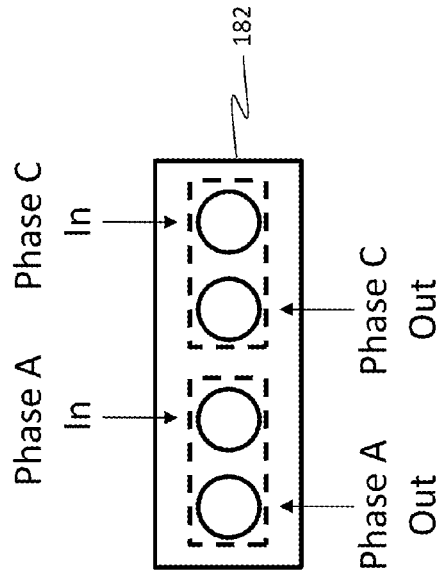
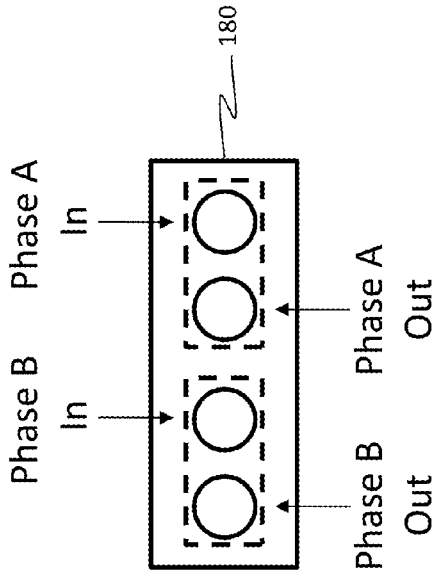

FIG. 4B

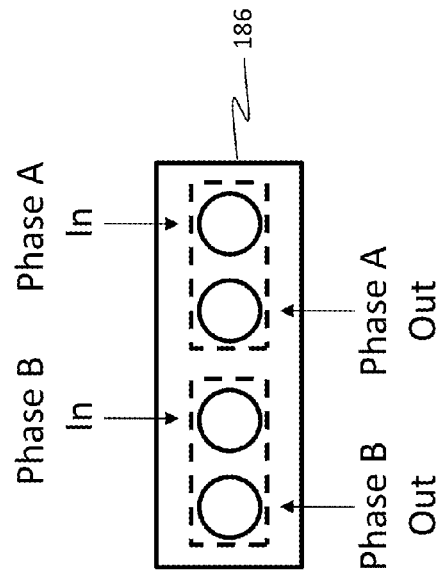
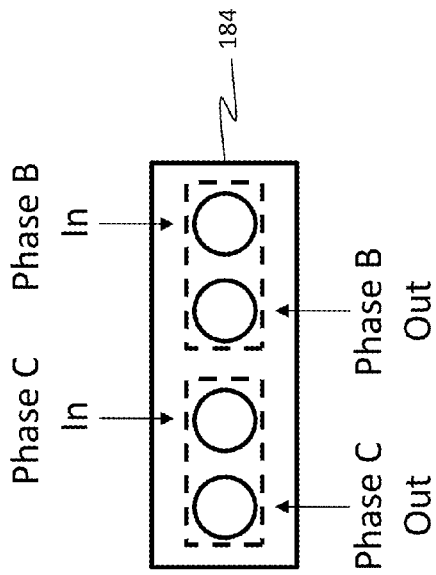

FIG. 4C

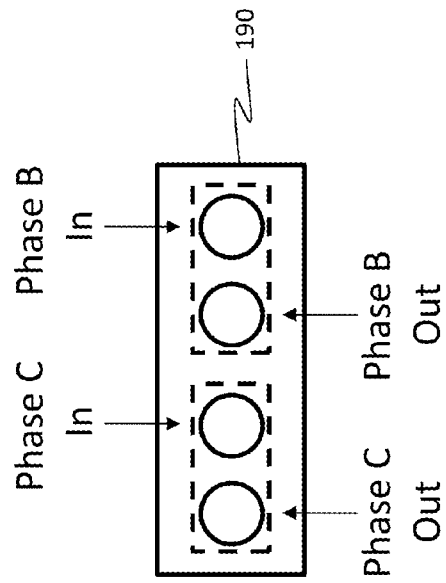
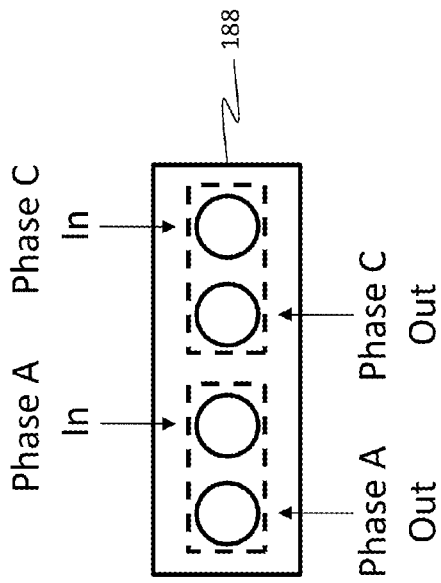

FIG. 4D

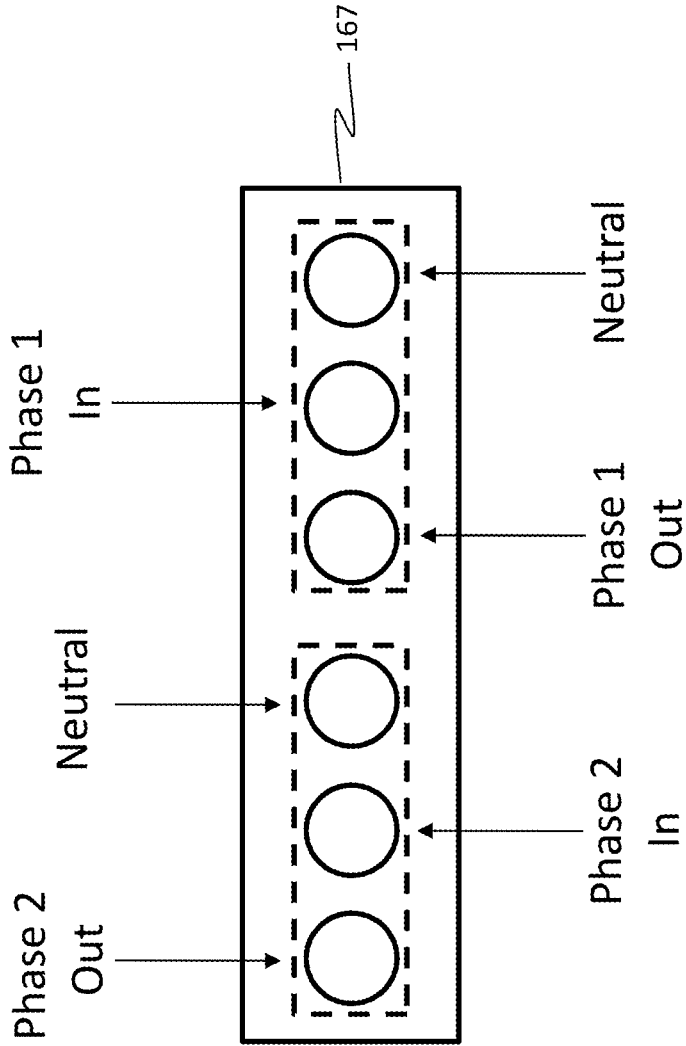

FIG. 4E

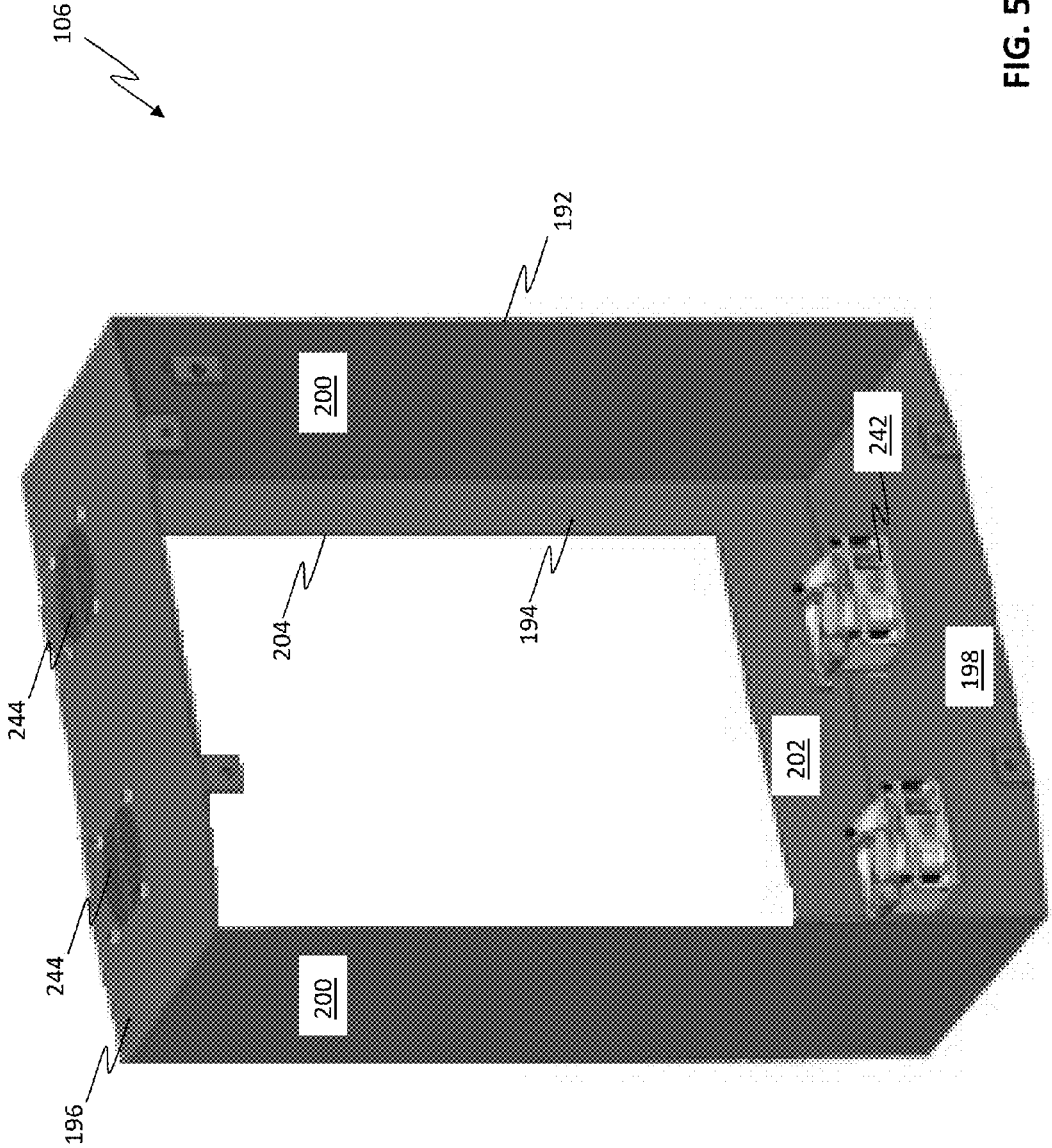

FIG. 5

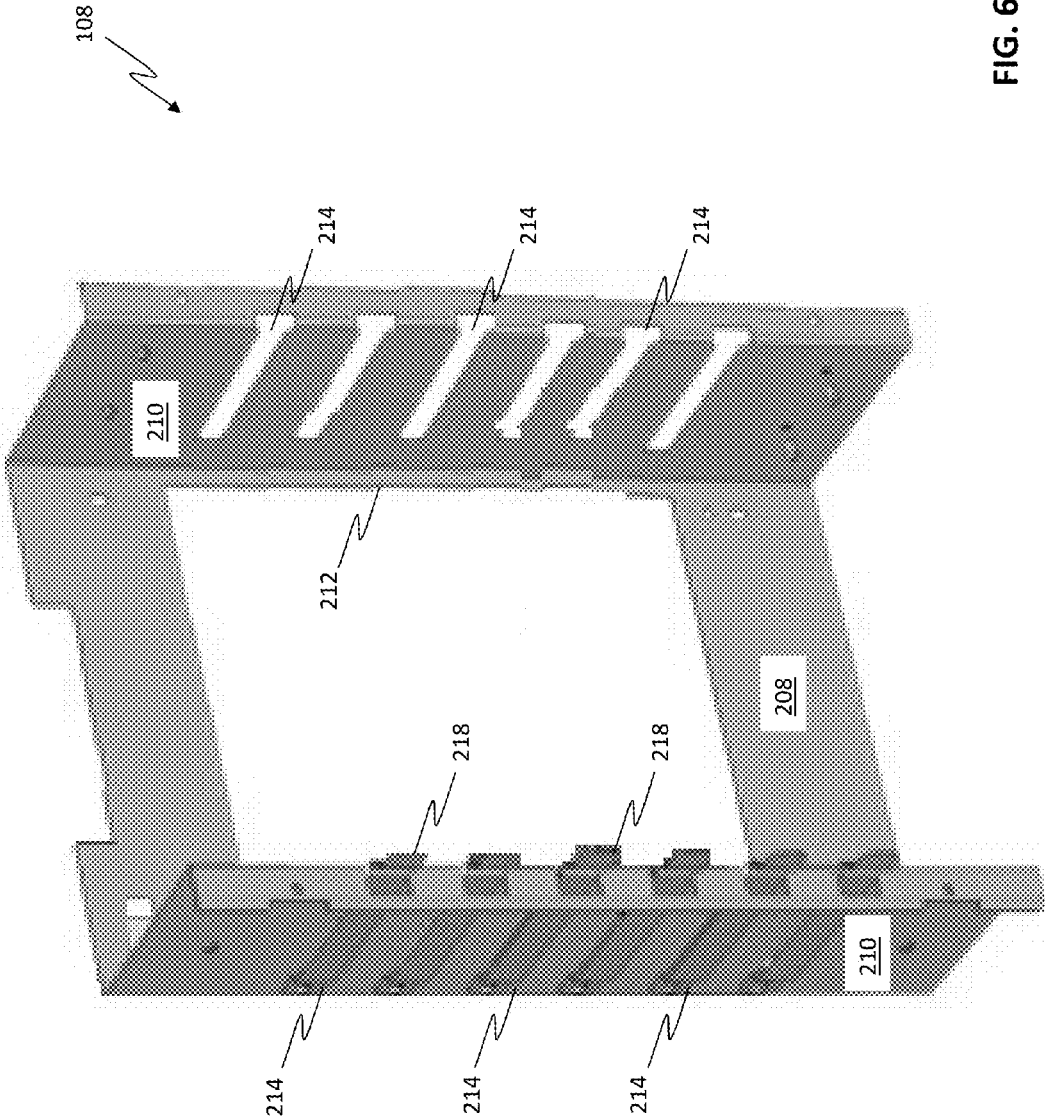

FIG. 6

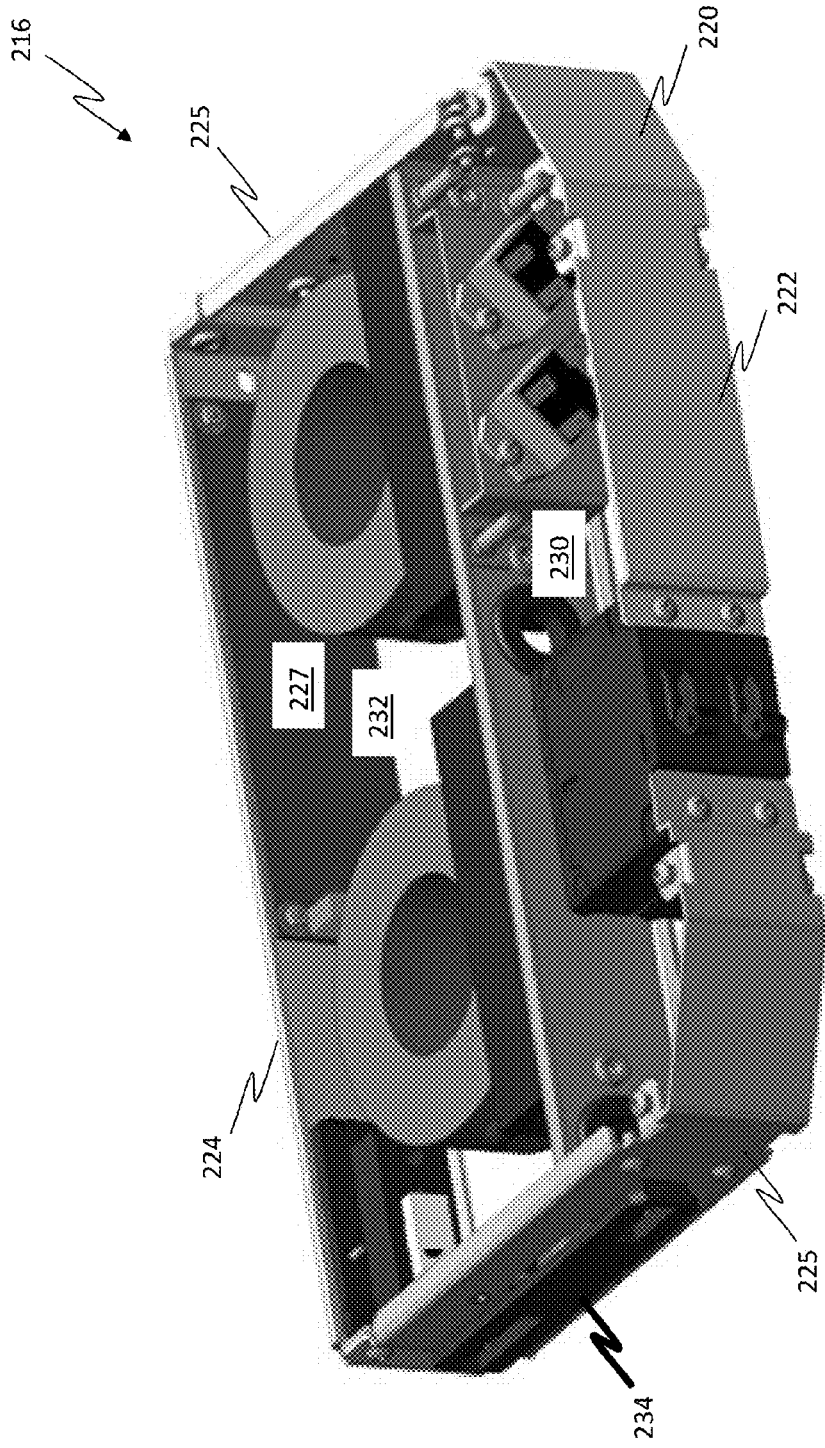
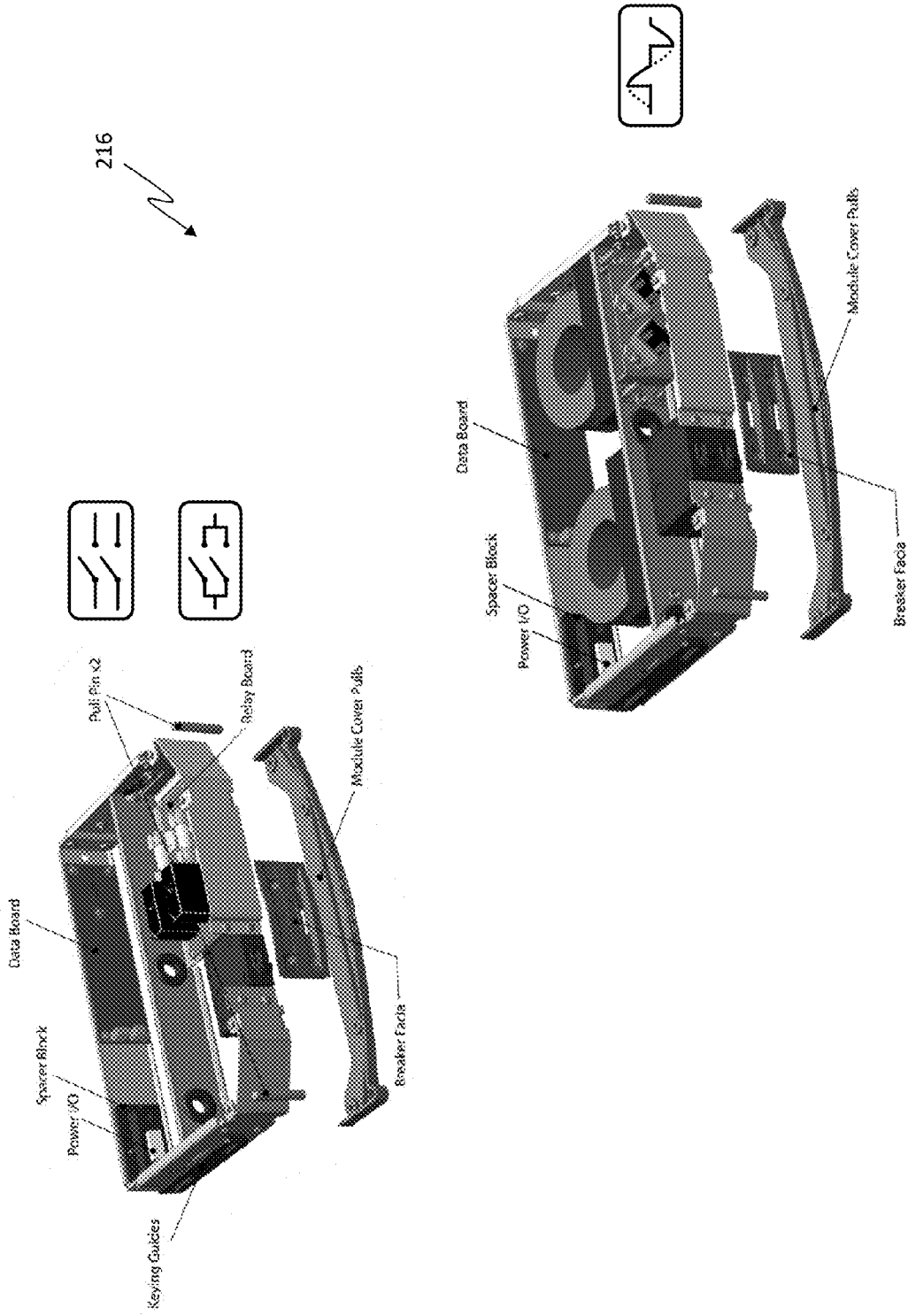

FIG. 7A



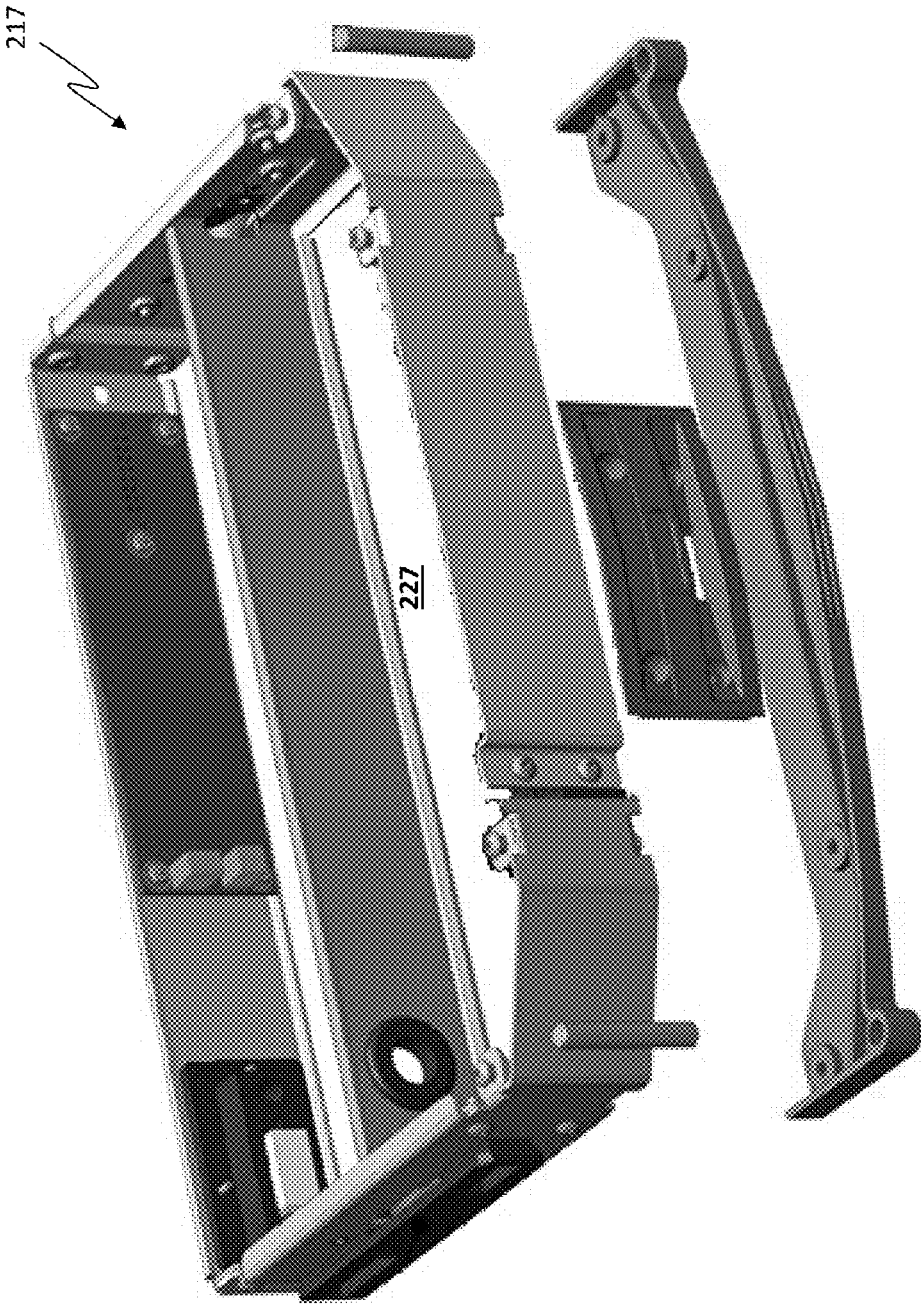
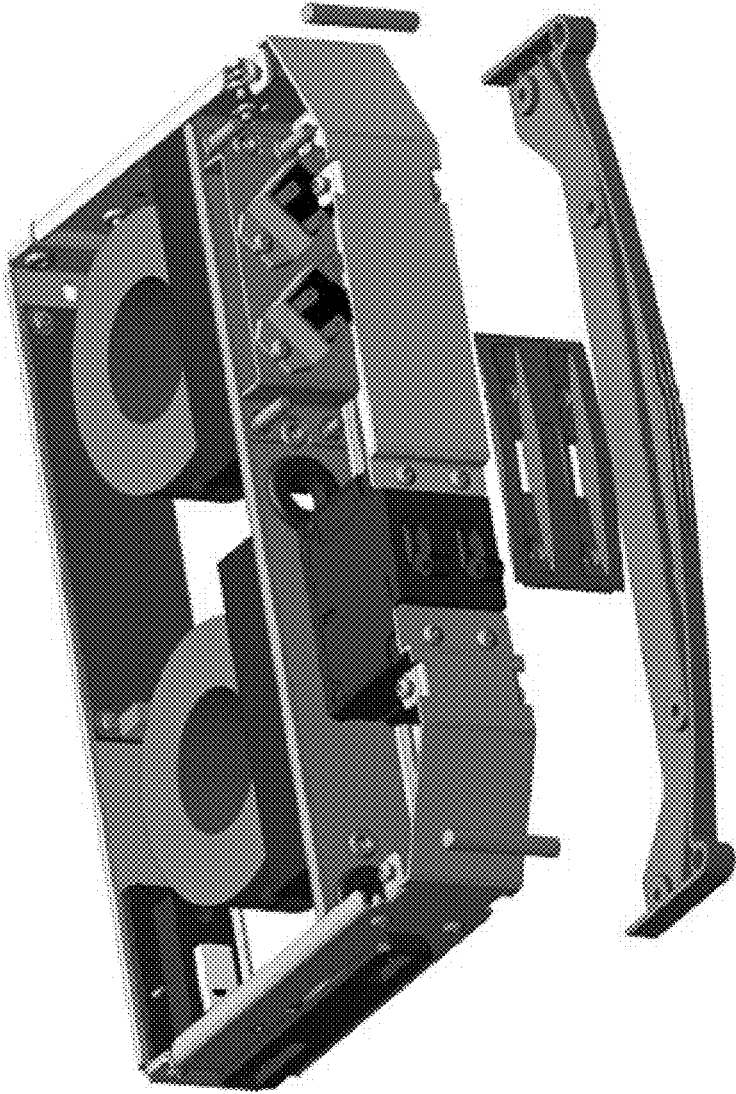

FIG. 7C

216



Two (2) SCR 120V  
10A Dimmers

FIG. 8

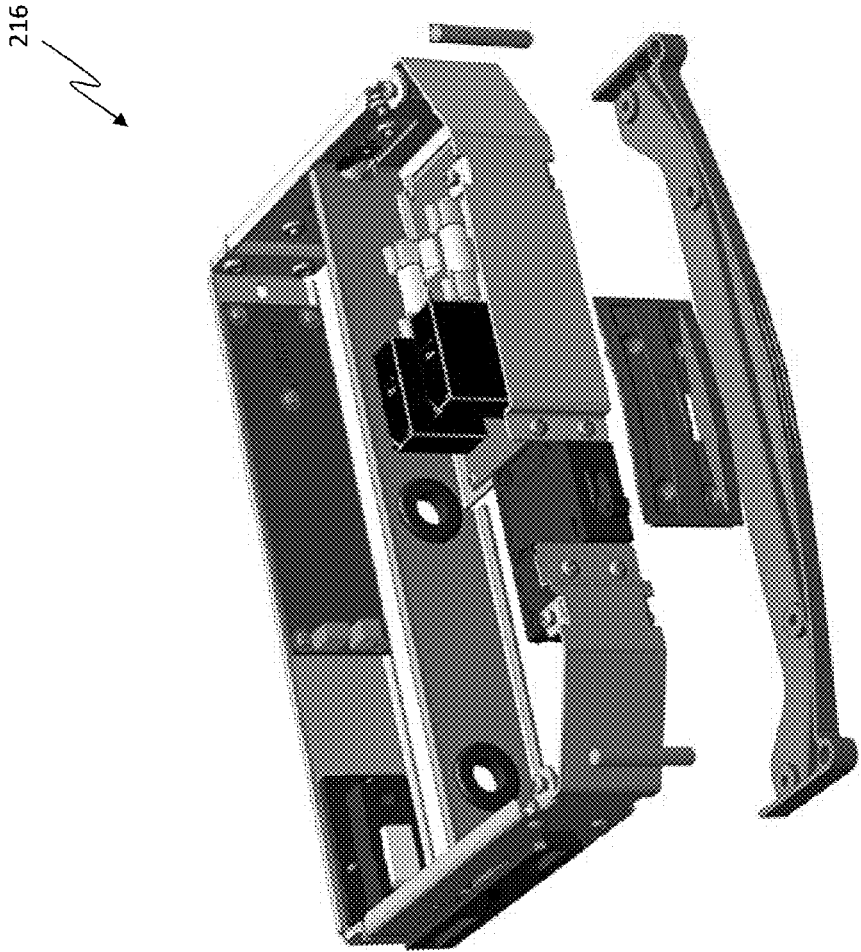

Two (2) Single-Pole  
20A 120V Relays

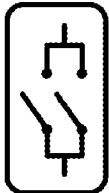

One (1) Double-  
Pole 20A 220V  
Relay

FIG. 9

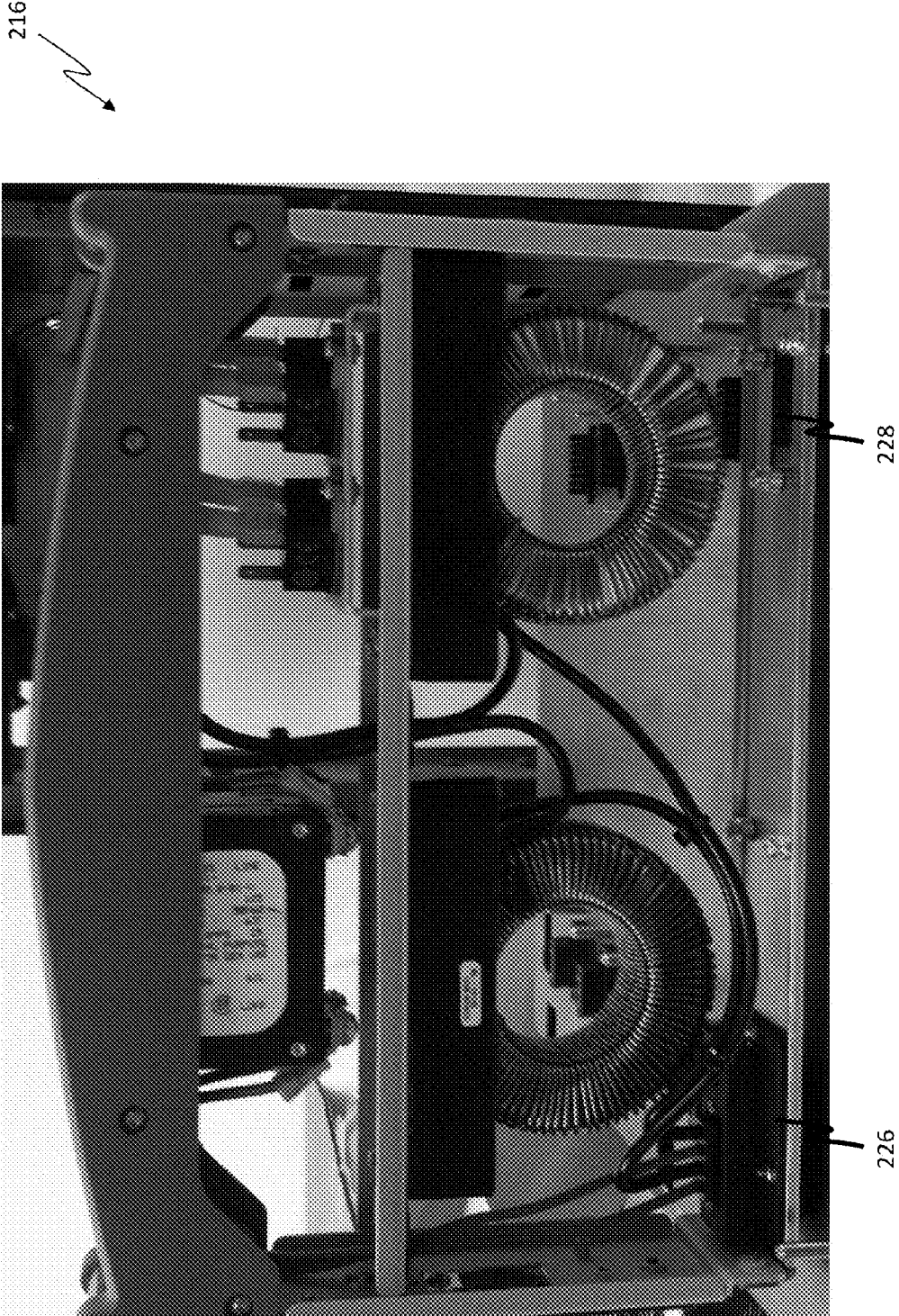

FIG. 10

110

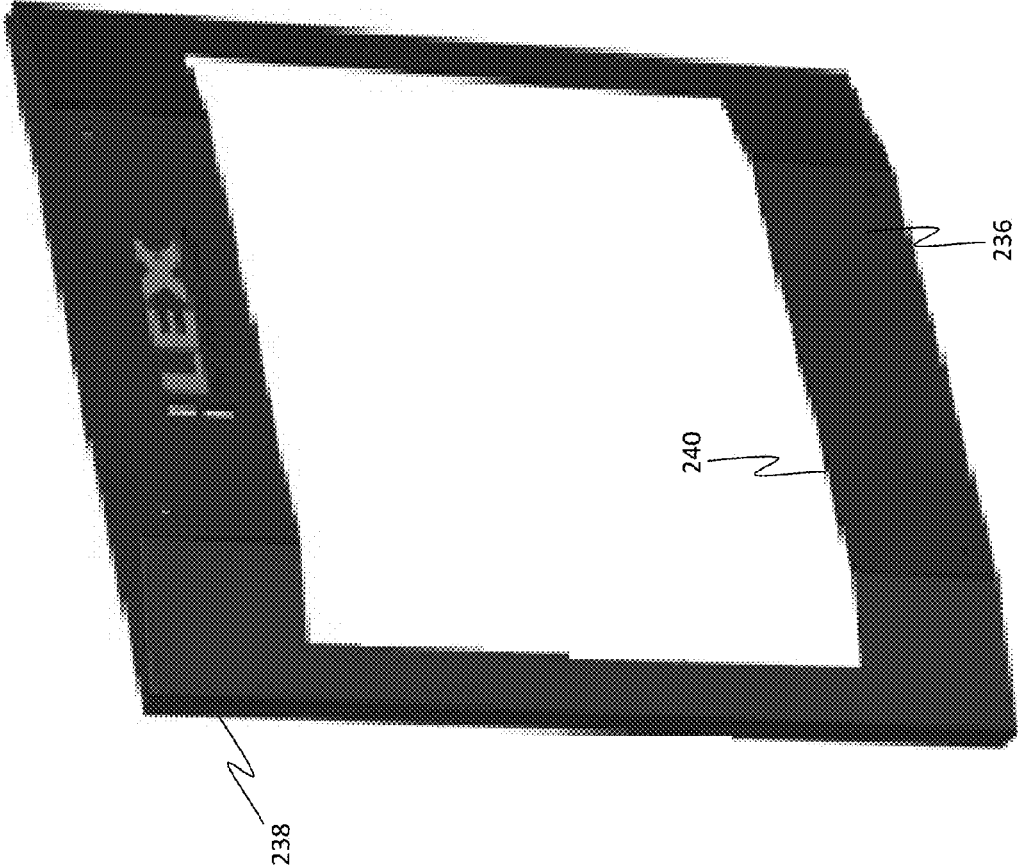
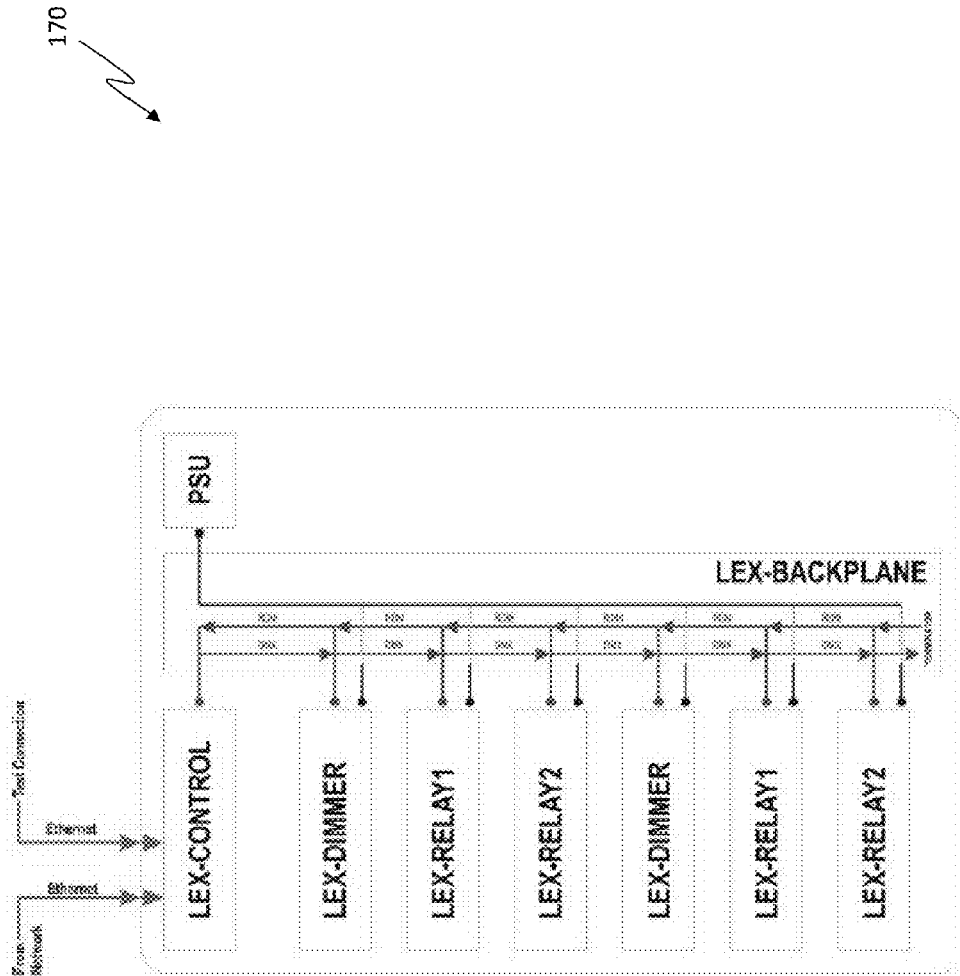

FIG. 11



Upto 15 Modules (30 channels) per Panel,  
One Control Module & One PSU

FIG. 12



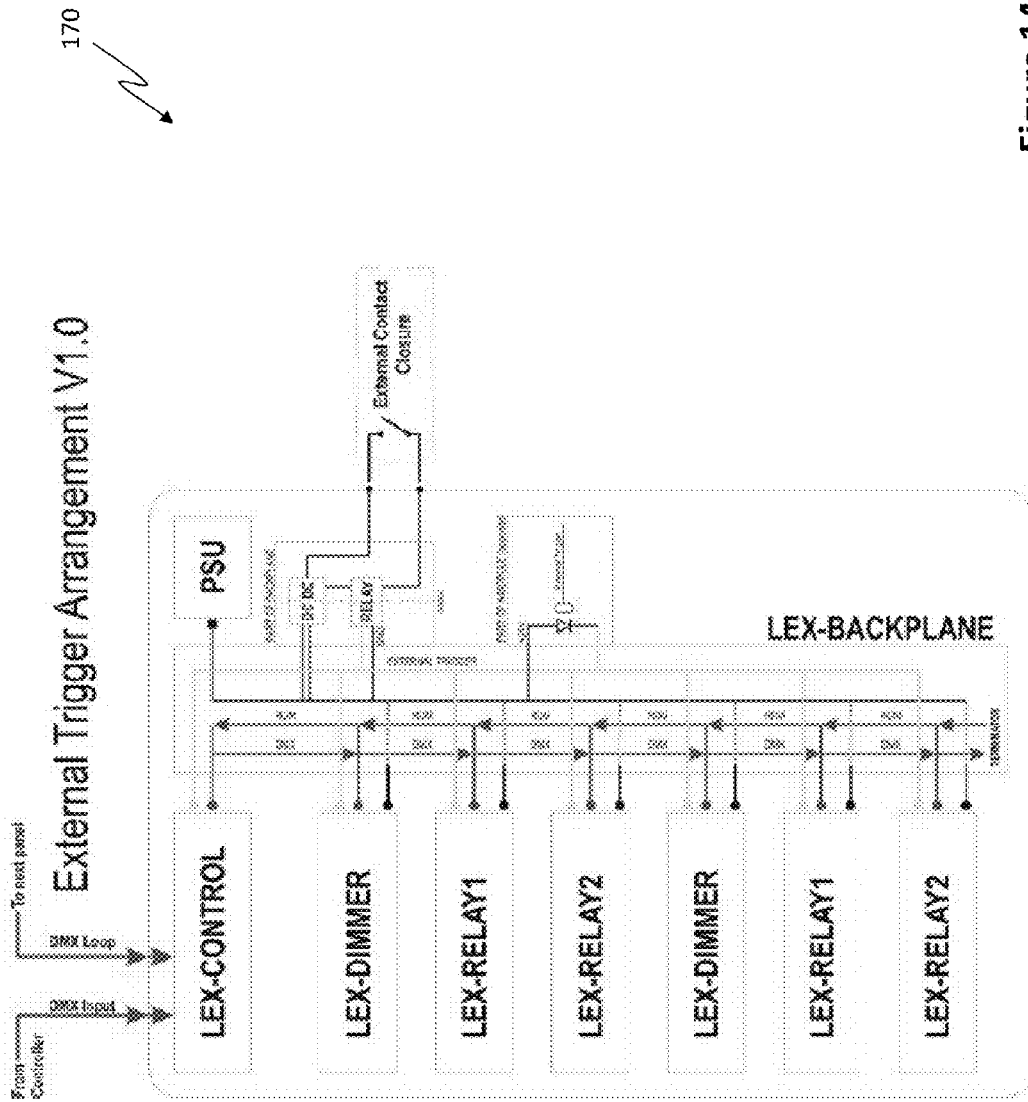

Figure 14

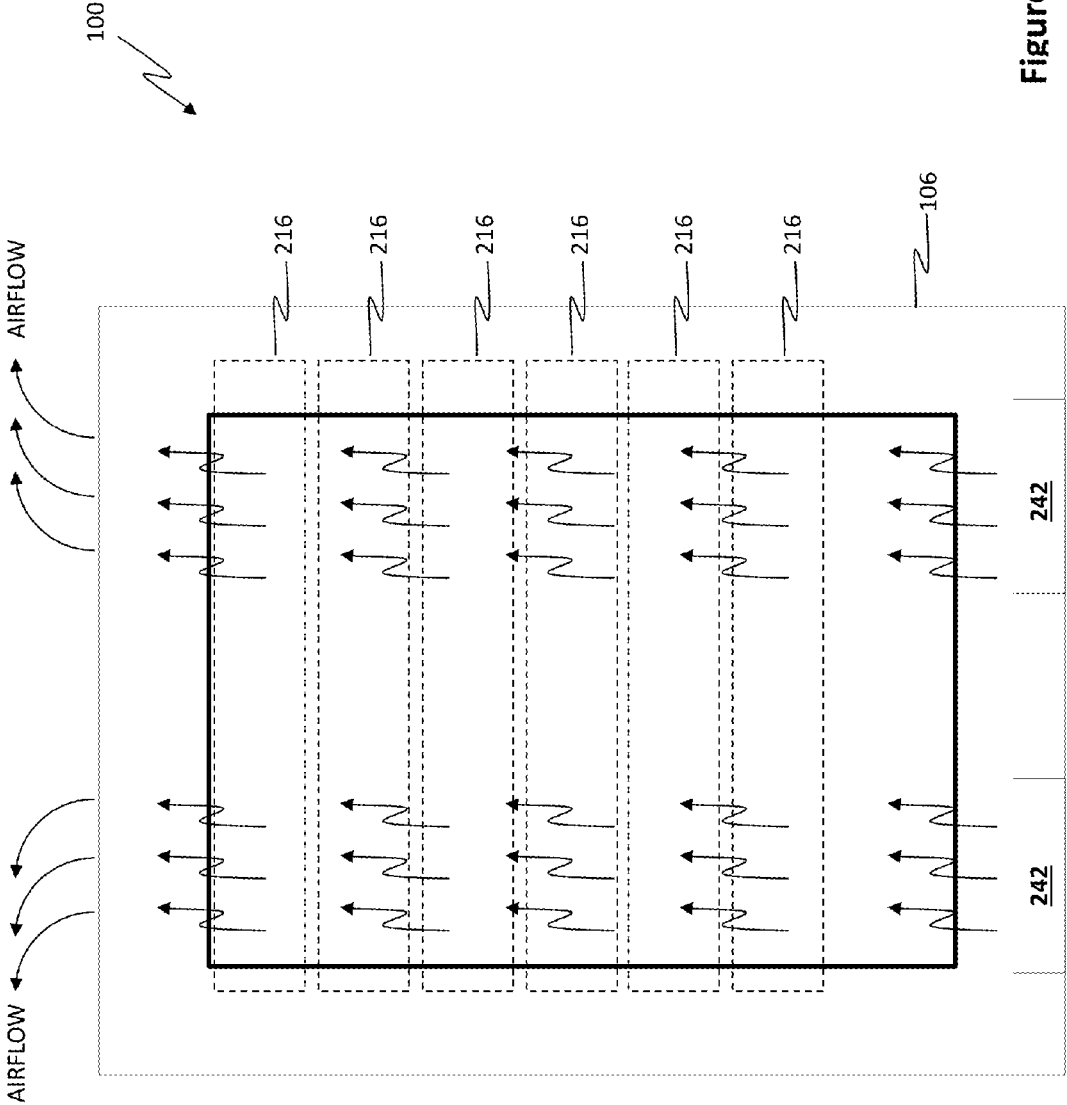

Figure 15

INSTALLATION PANELS				
MODULE CAPACITY	HEIGHT	WIDTH	DEPTH	PANEL CAPACITY
3	11.2"	12.8"	12.2"	40A 3Ø 208Y/120V
6	16.6"	12.8"	12.2"	80A 3Ø 208Y/120V
9	22.0"	12.8"	12.2"	120A 3Ø 208Y/120V
12	27.4"	12.8"	12.2"	160A 3Ø 208Y/120V
15	32.8"	12.8"	12.2"	200A 3Ø 208Y/120V

Figure 16

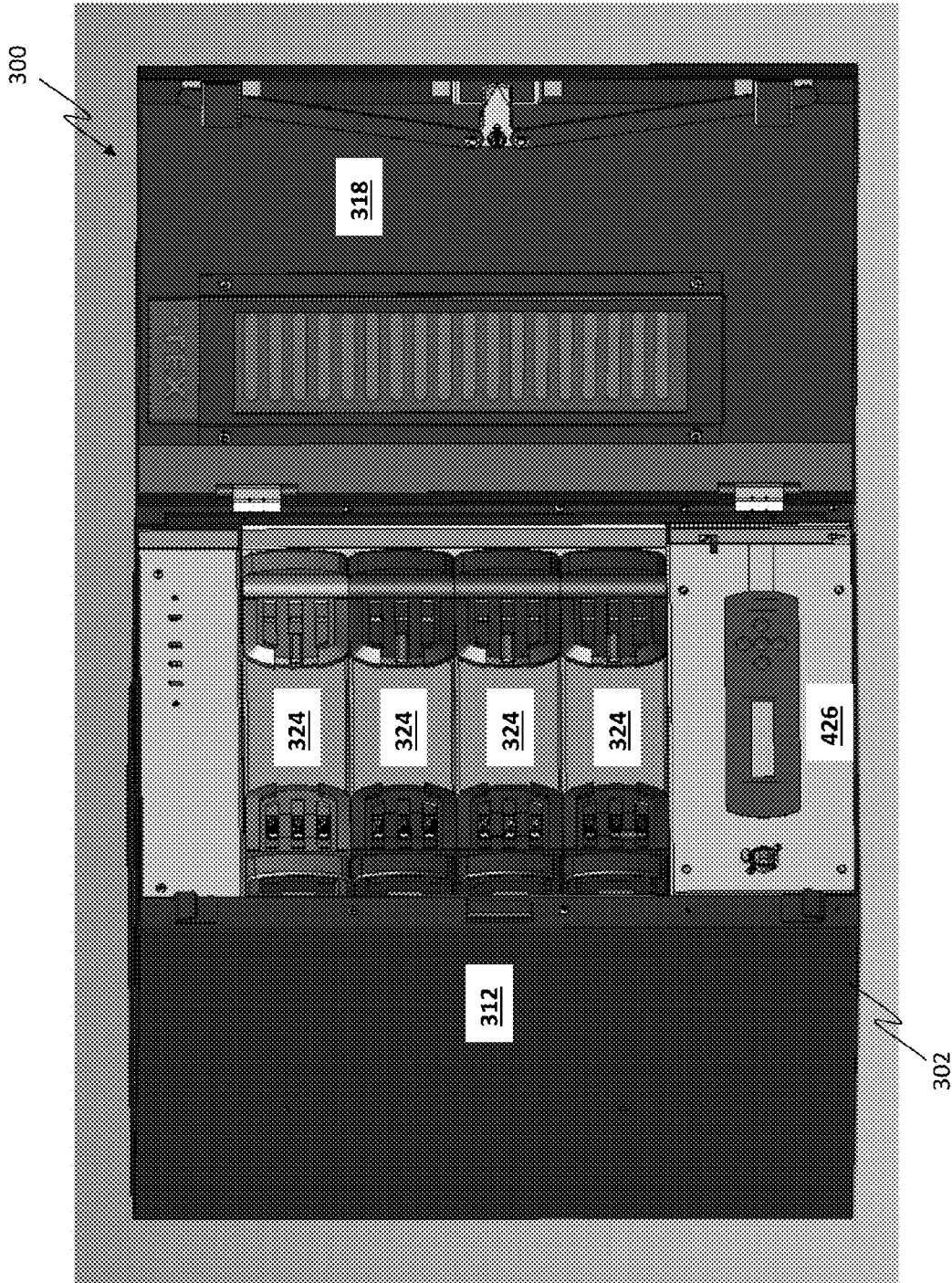

Figure 17

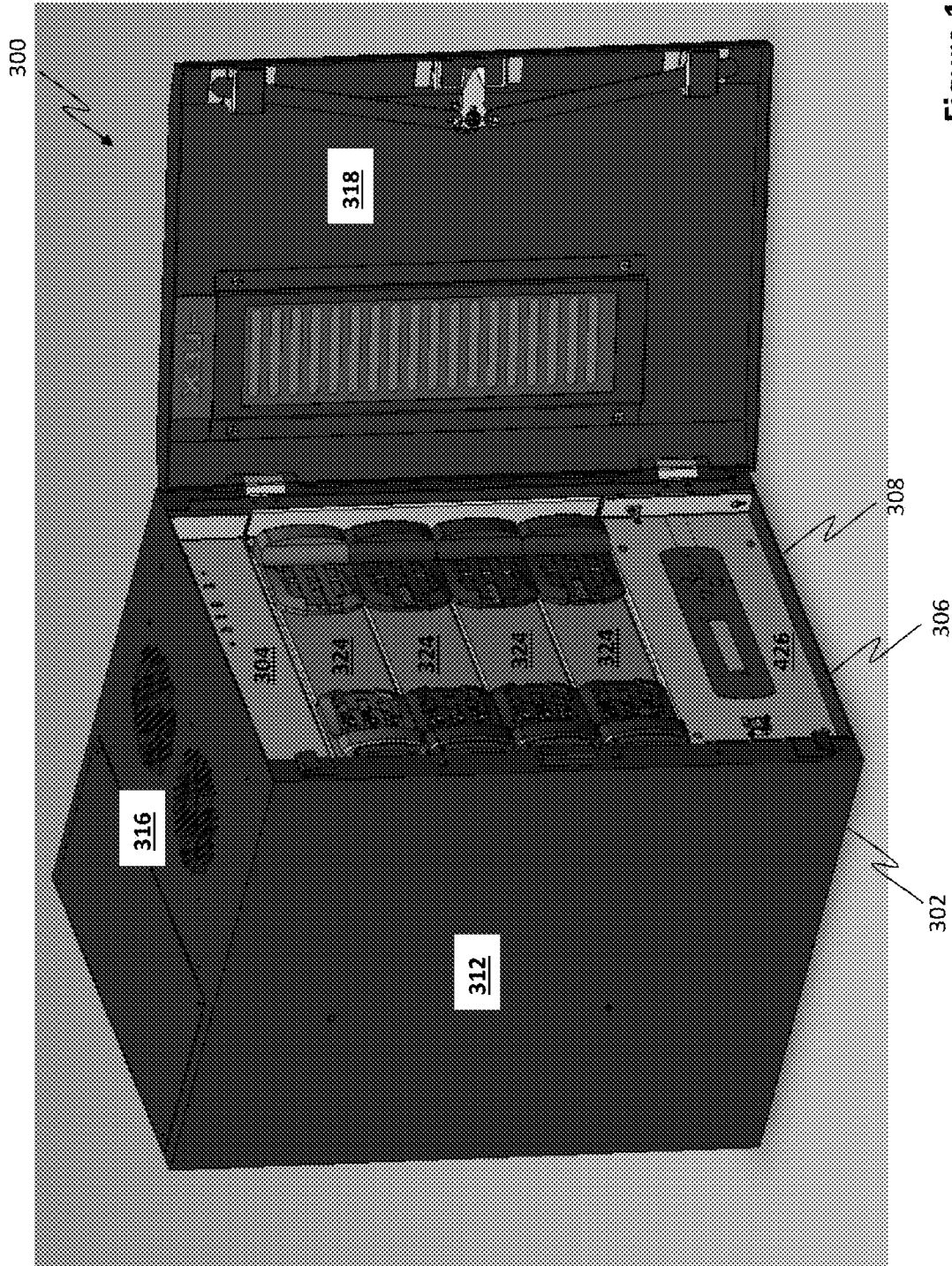

Figure 18

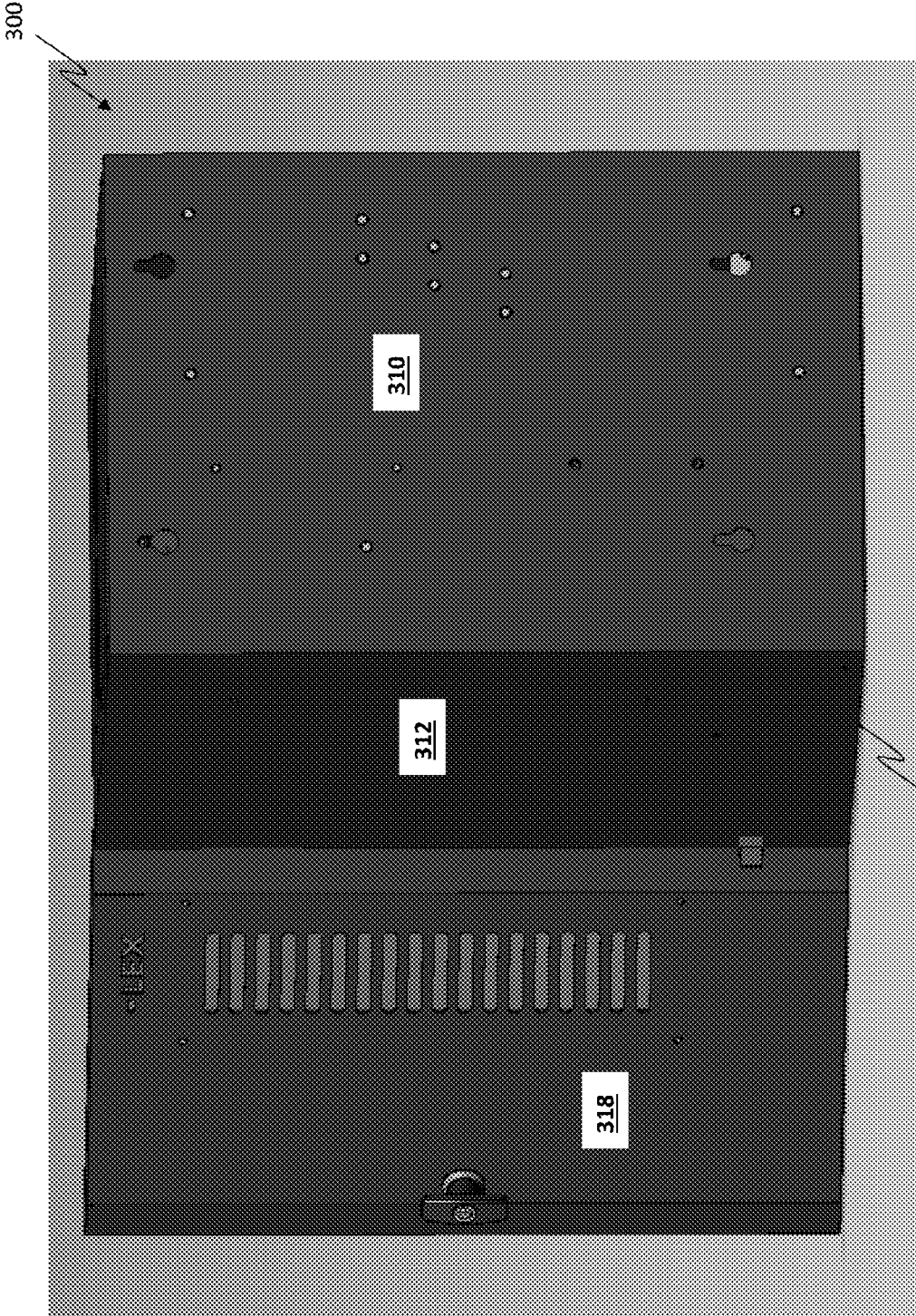

Figure 19

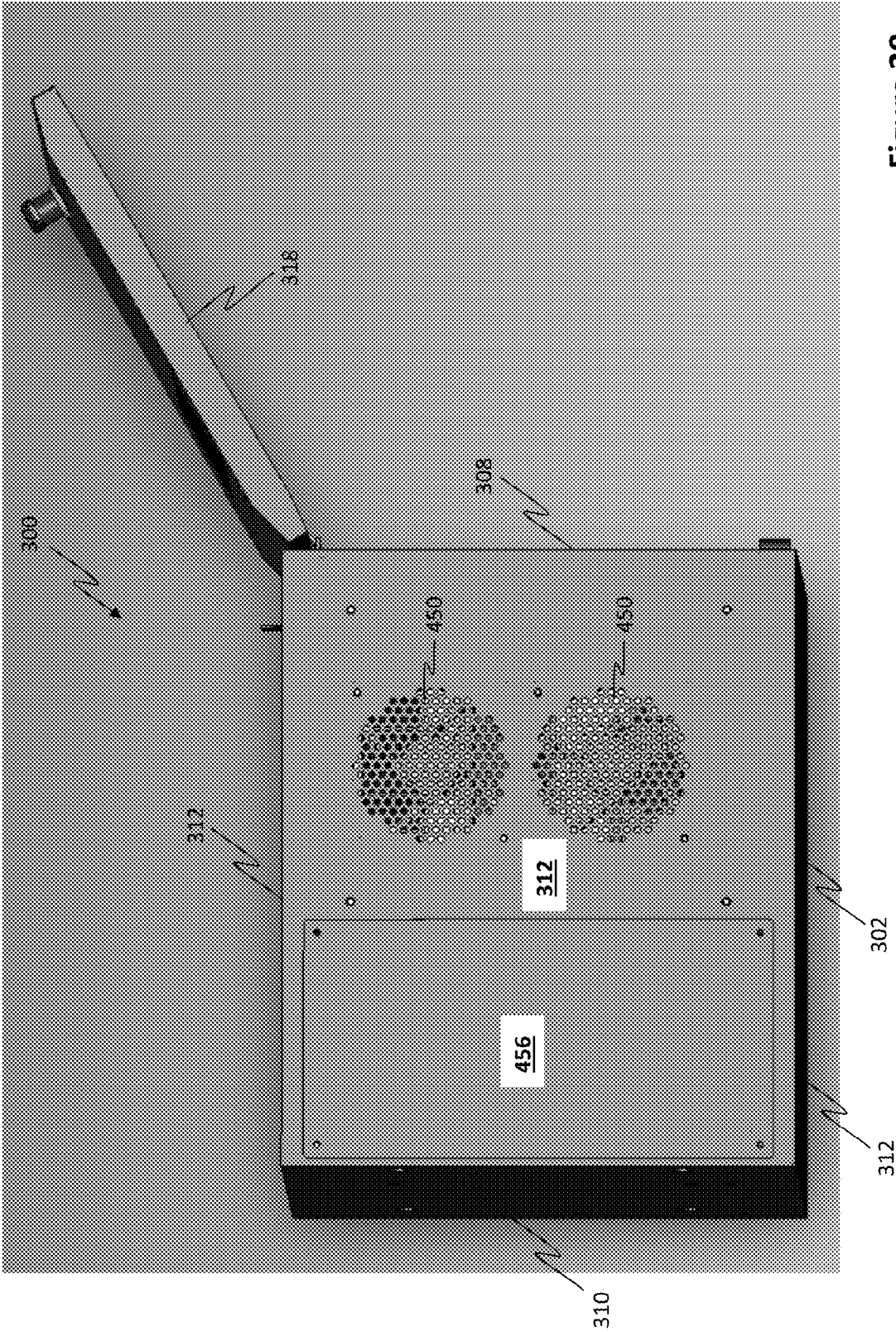

Figure 20

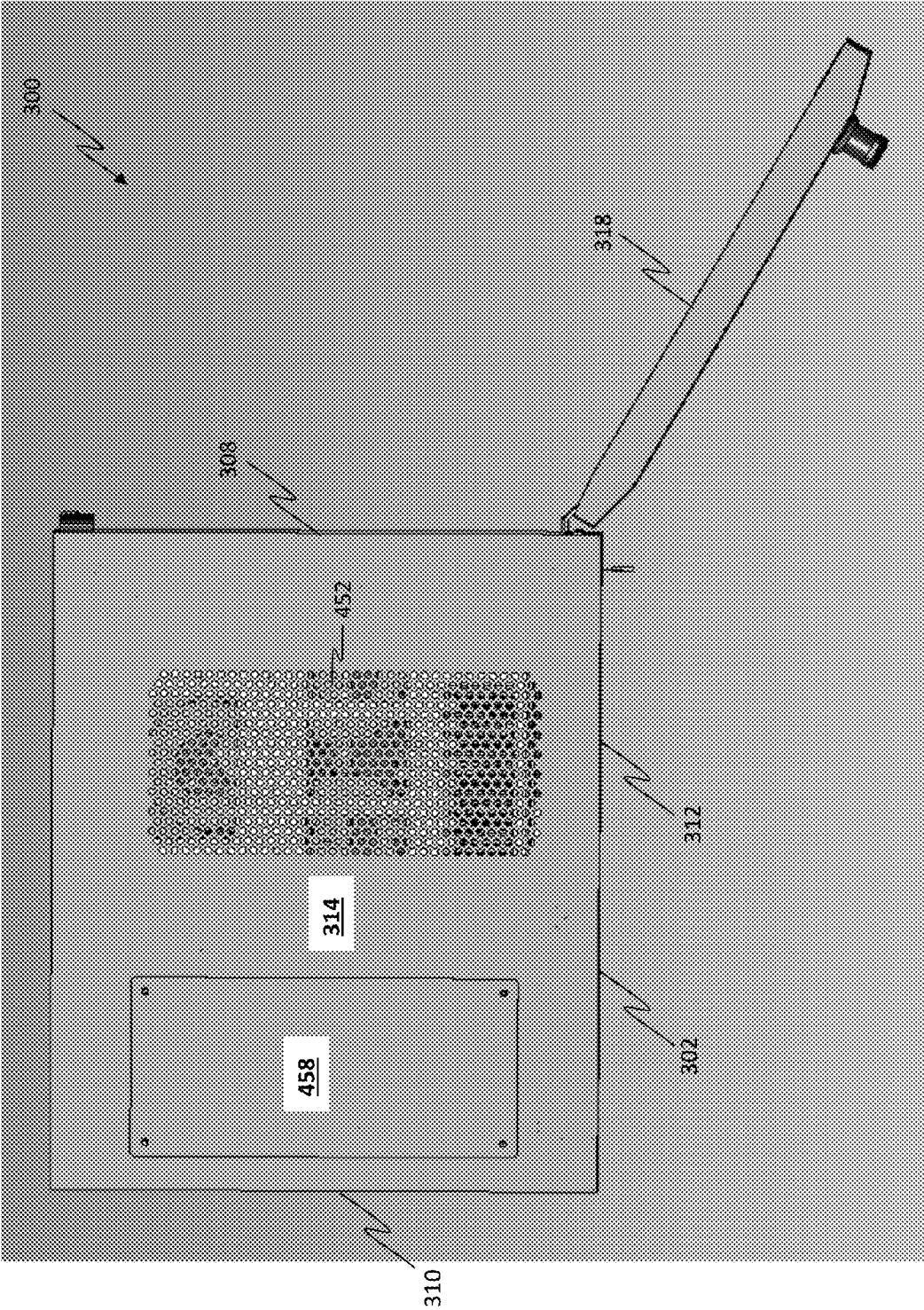

Figure 21

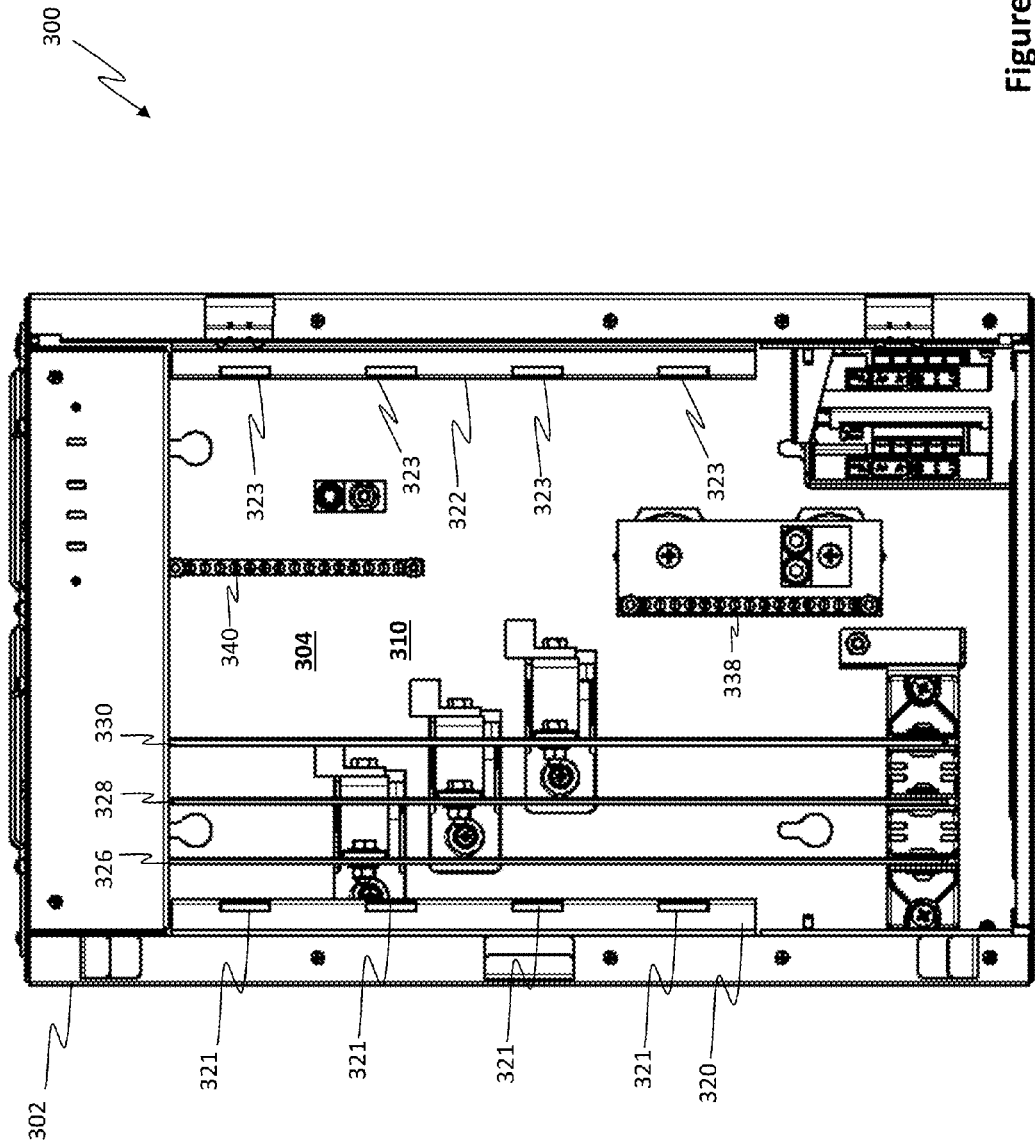

Figure 22A



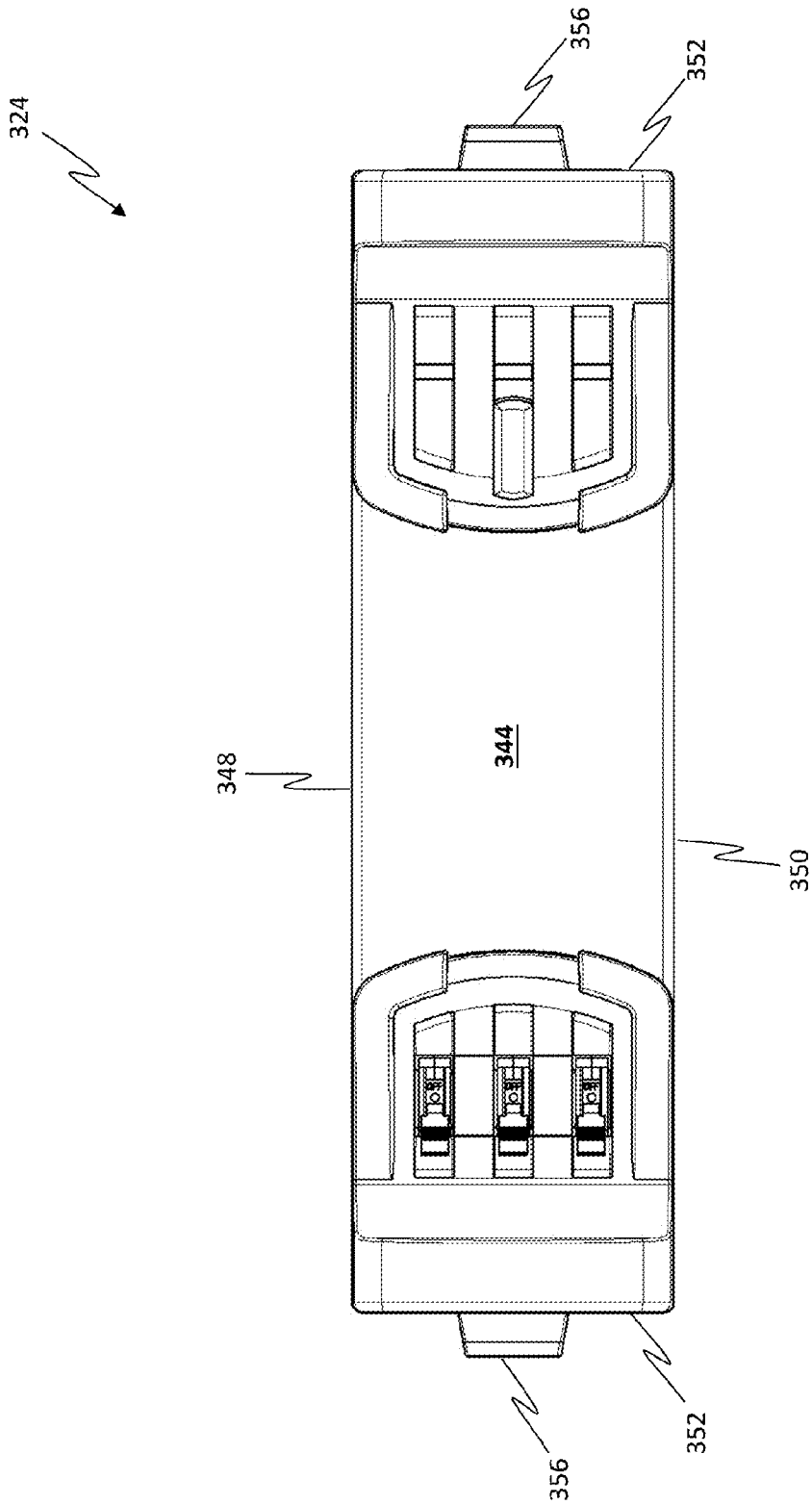

Figure 23

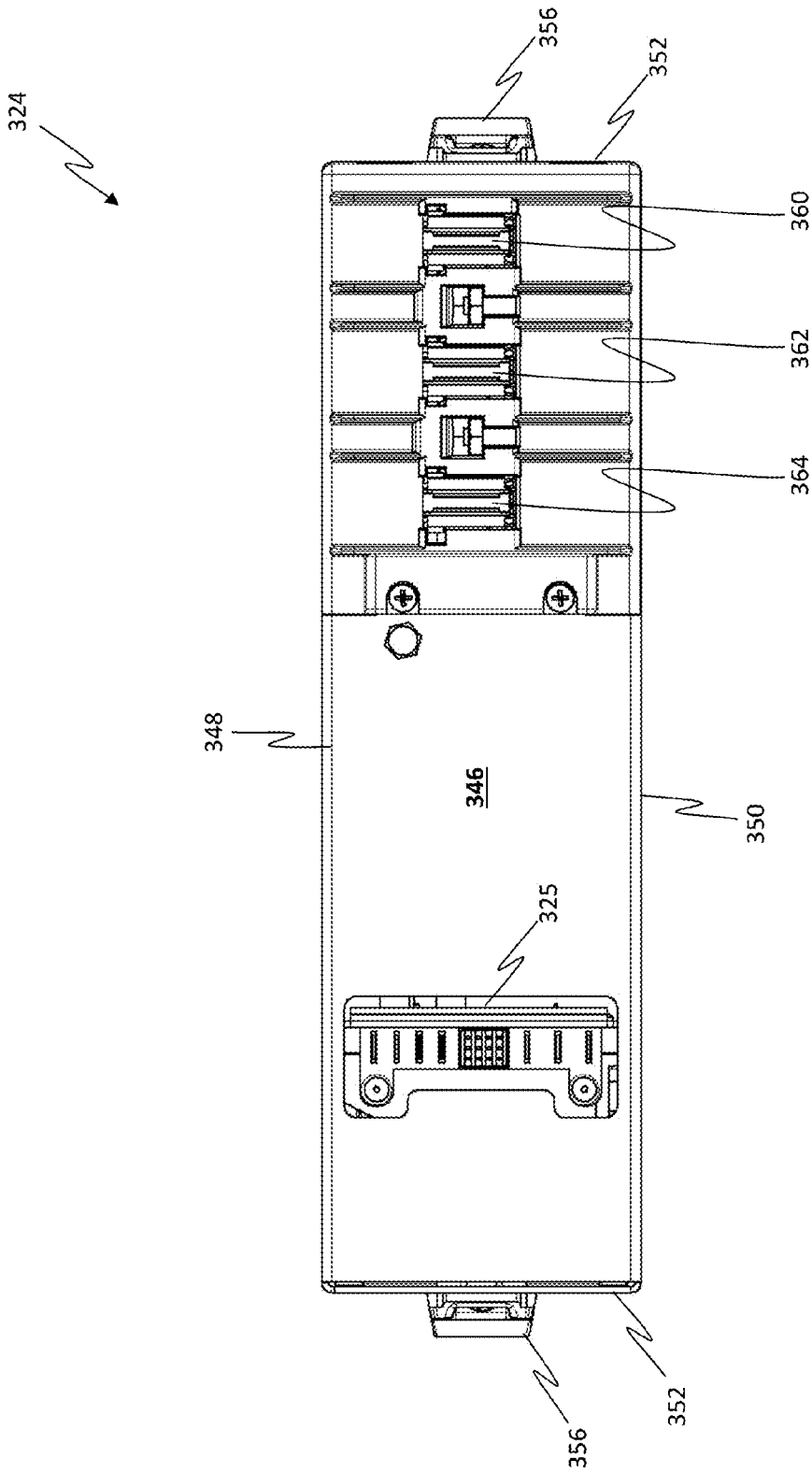

Figure 24

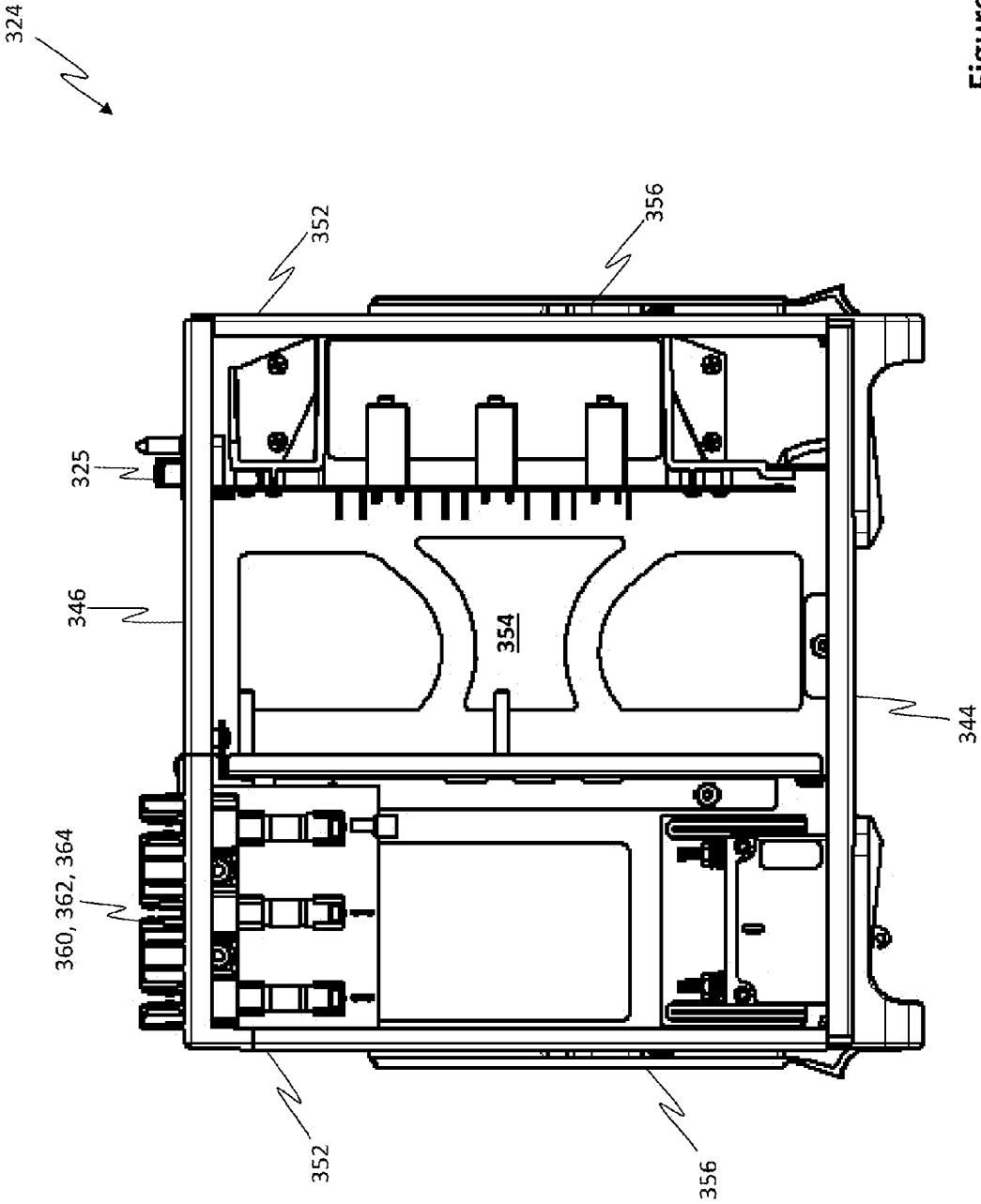

Figure 25

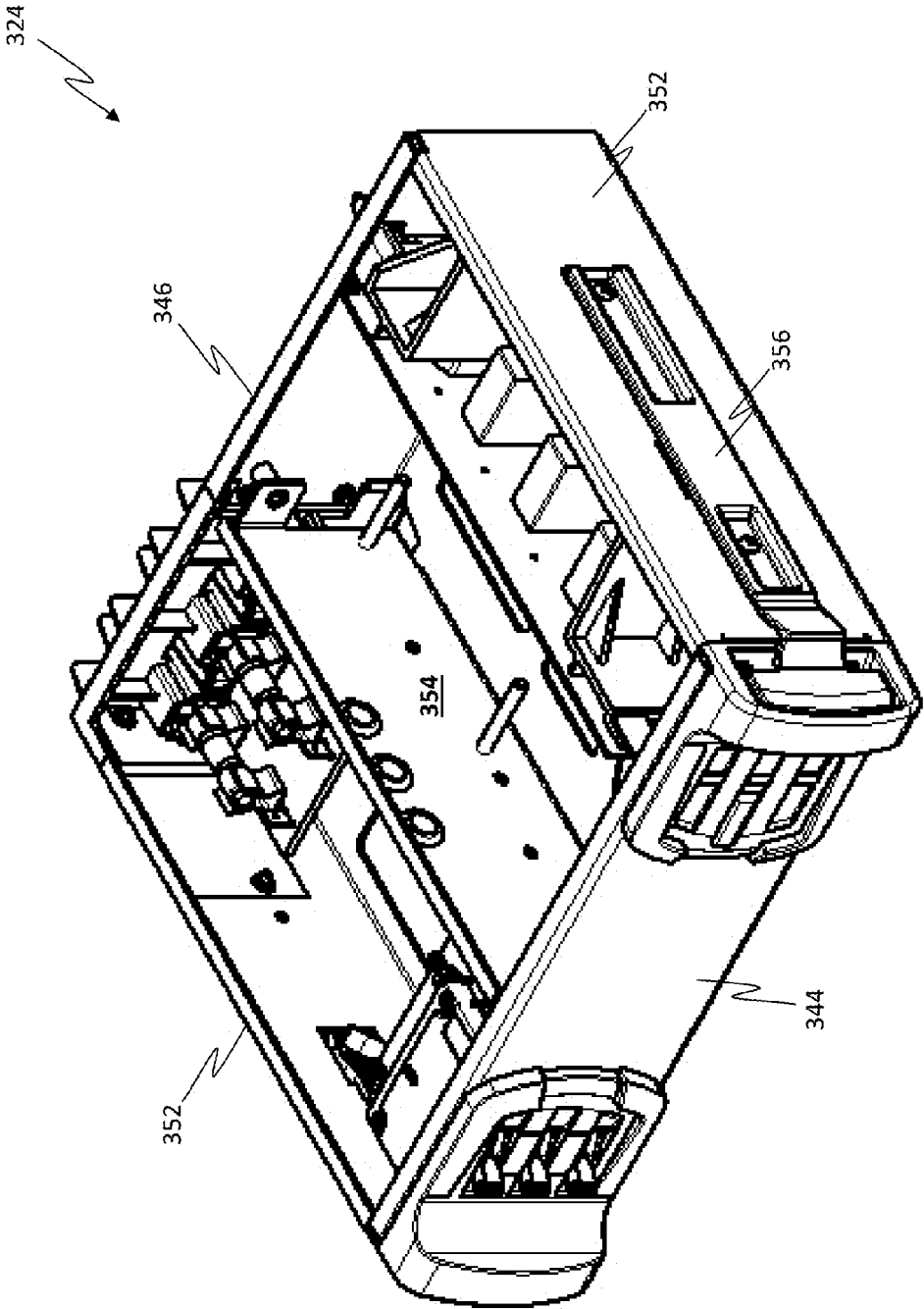

Figure 26

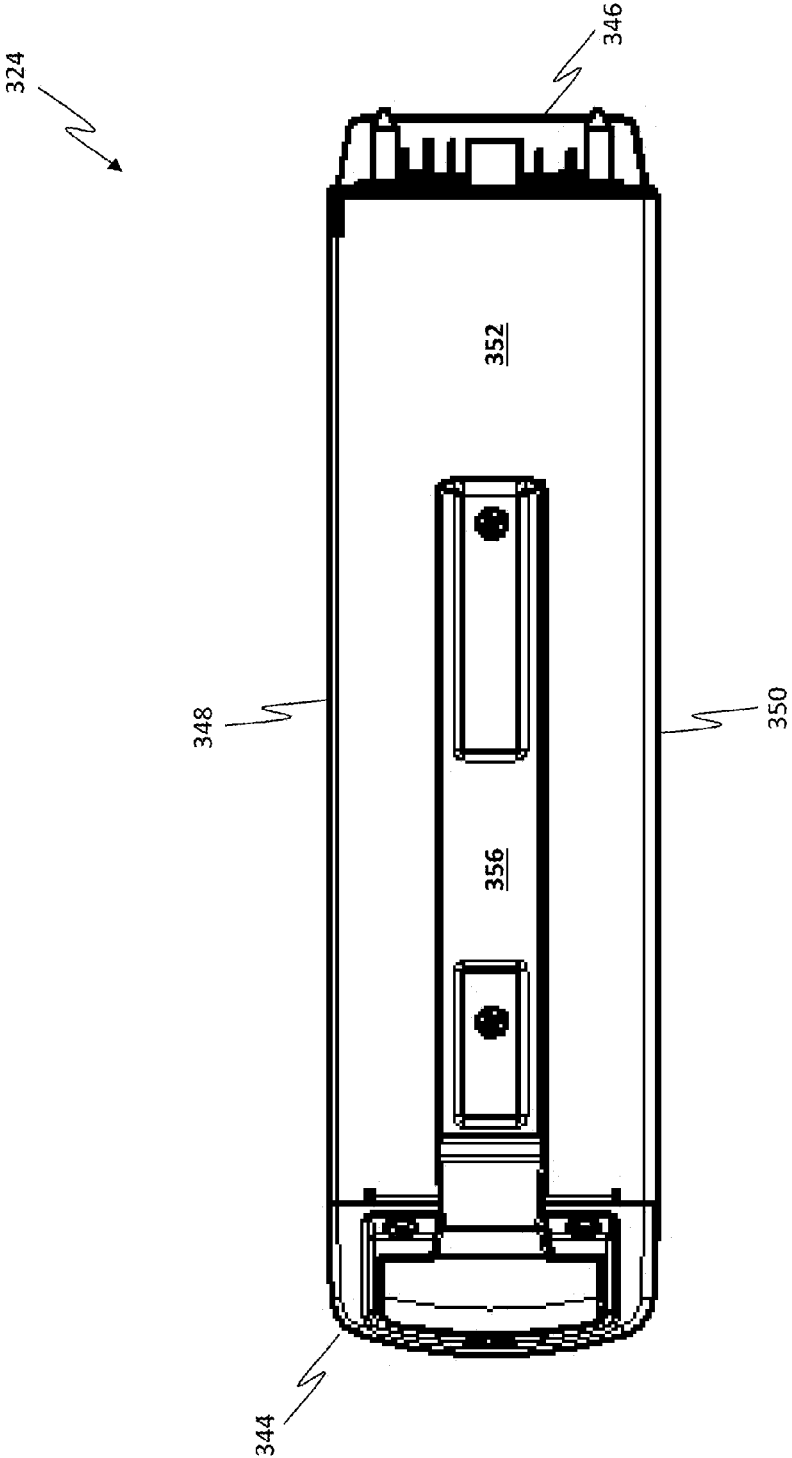

Figure 27

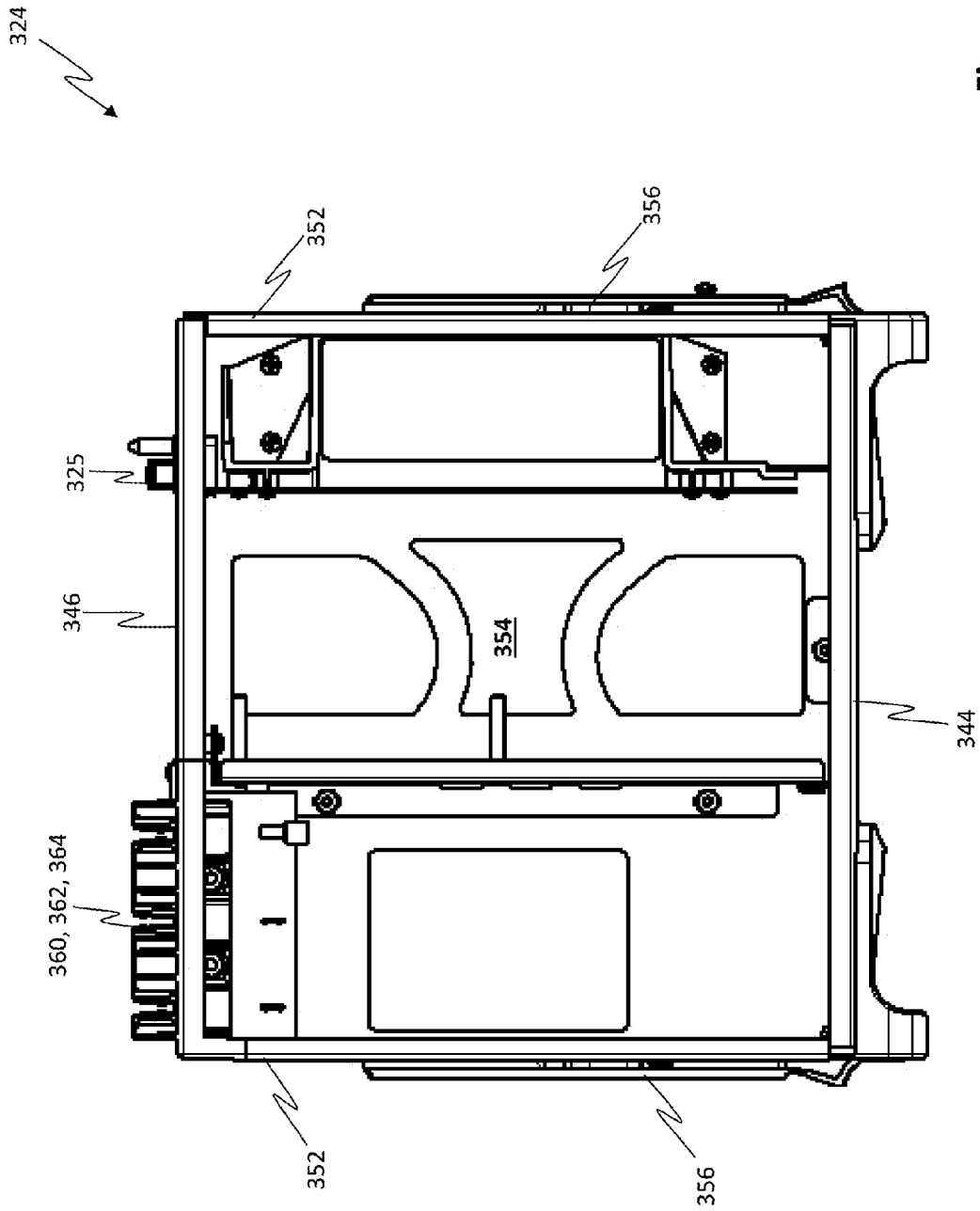

Figure 28

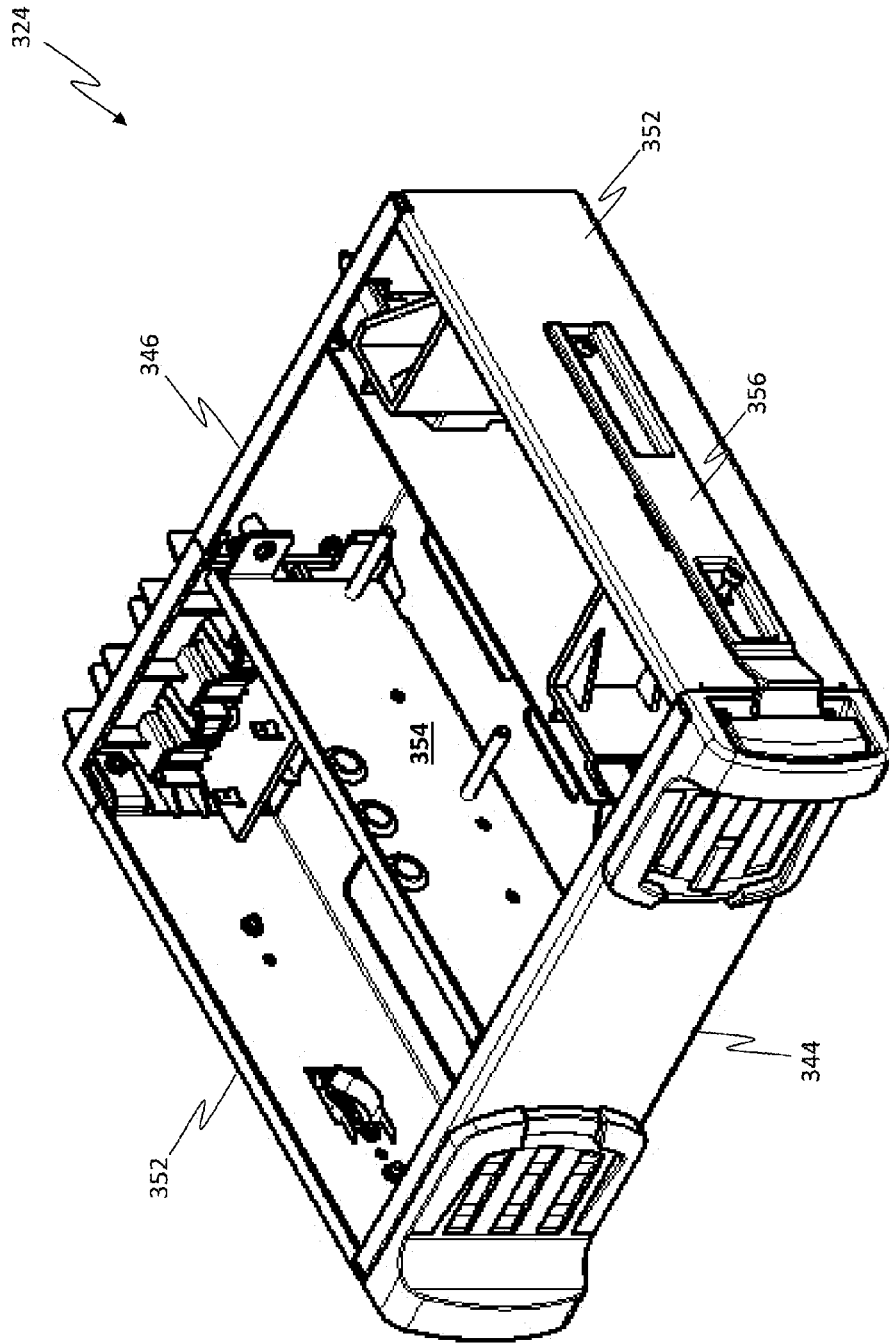

Figure 29

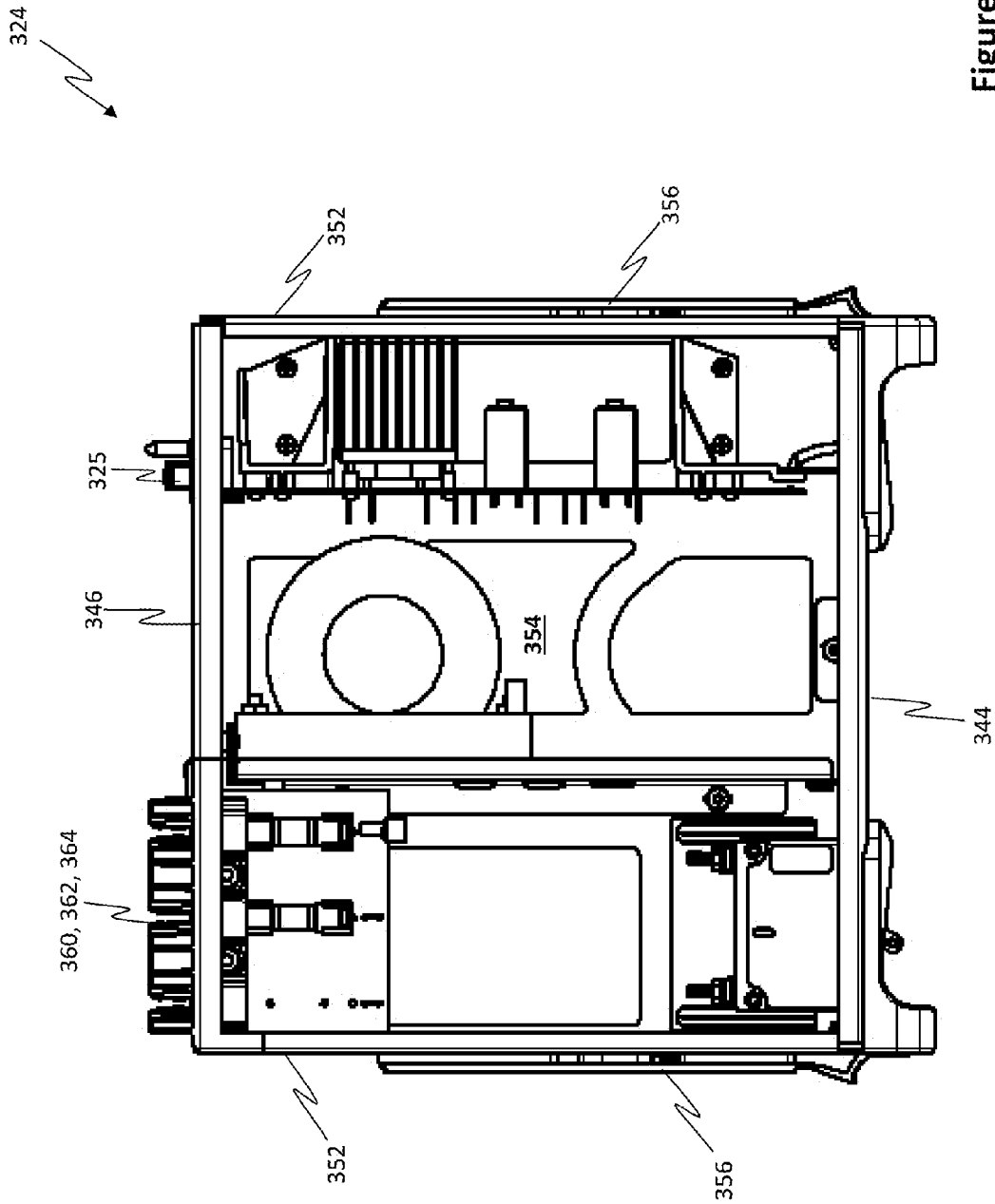

Figure 30

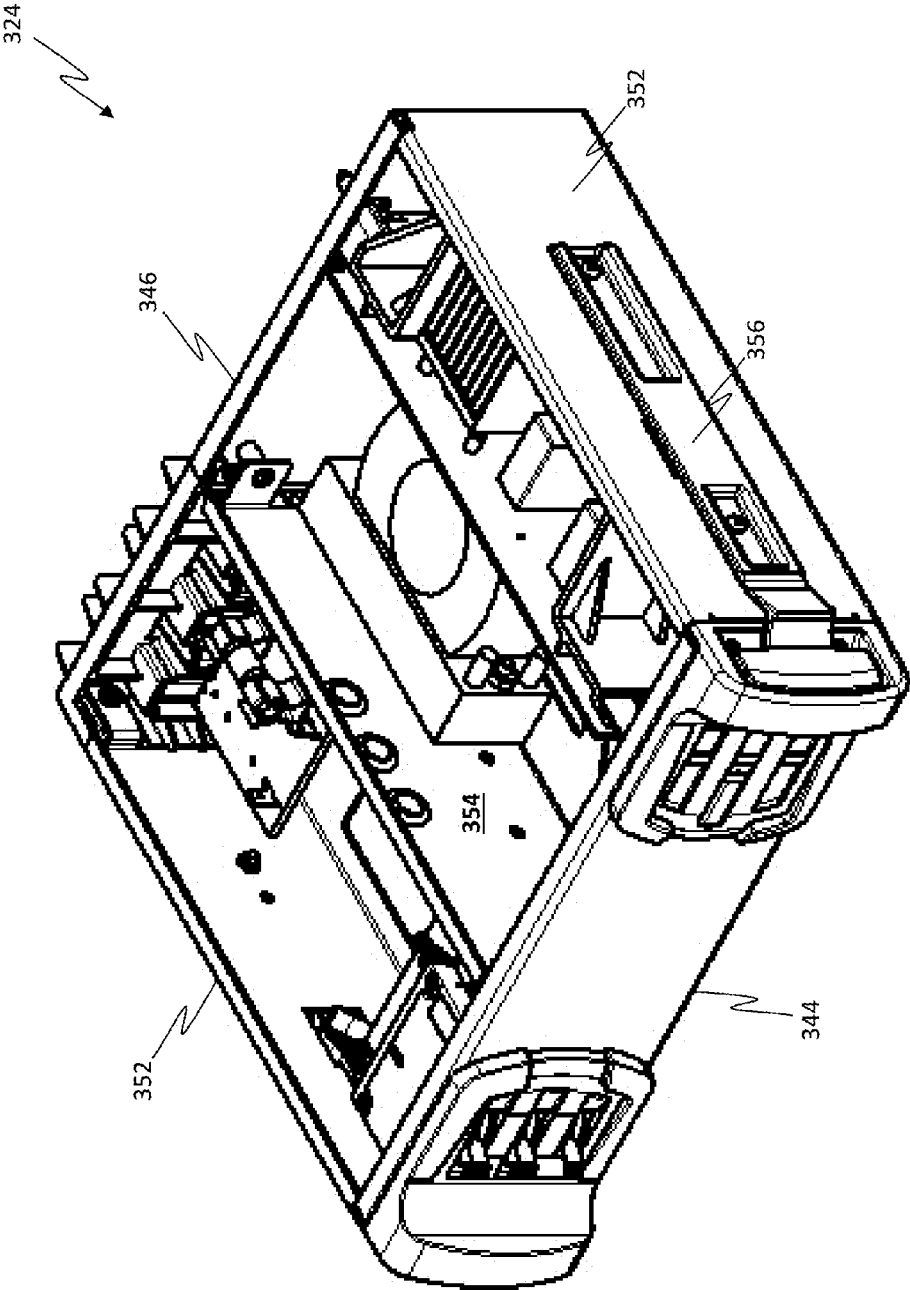

Figure 31

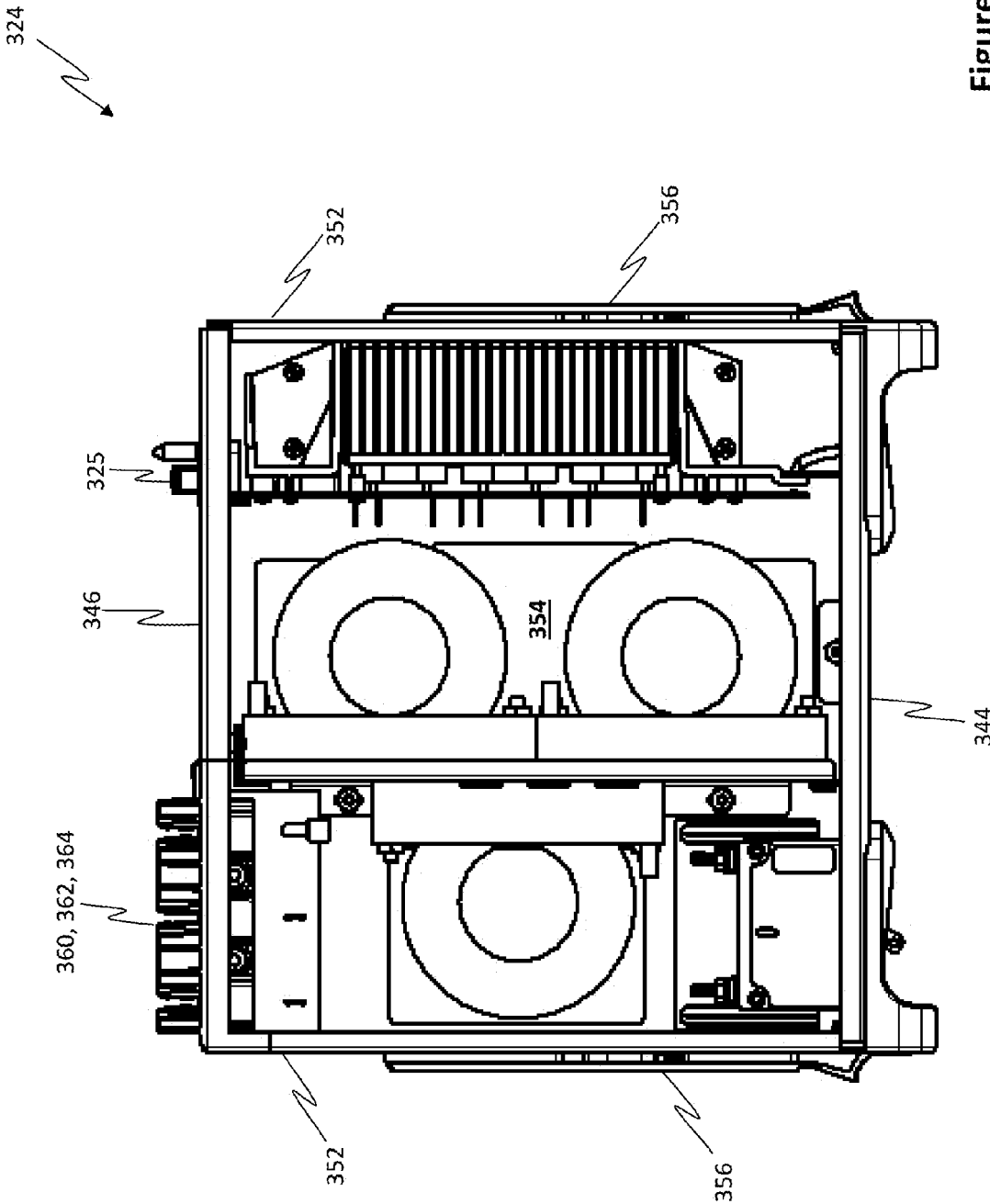

Figure 32

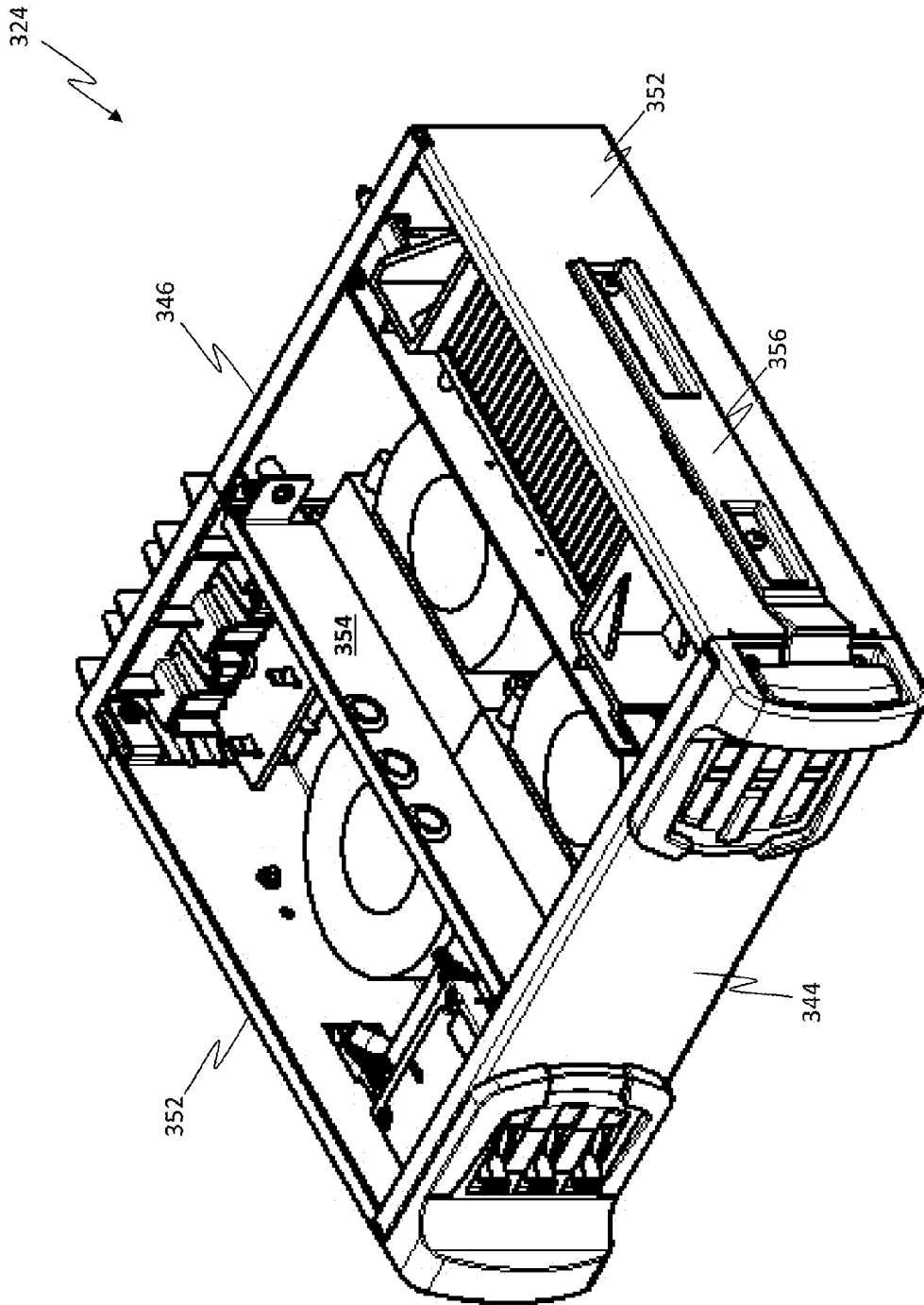

Figure 33A

208Y/120 VAC                      240 VAC  
3 Phase, 60Hz                      Single Phase, 60Hz  
(H,H,H,N,G.)                      (H,H,N,G.)

TRIO-I-4	80 Amps	120 Amps
TRIO-I-8	160 Amps	240 Amps
TRIO-I-16	310 Amps	310 Amps

Four (4)

Eight (8)

Sixteen (16)

Figure 33B

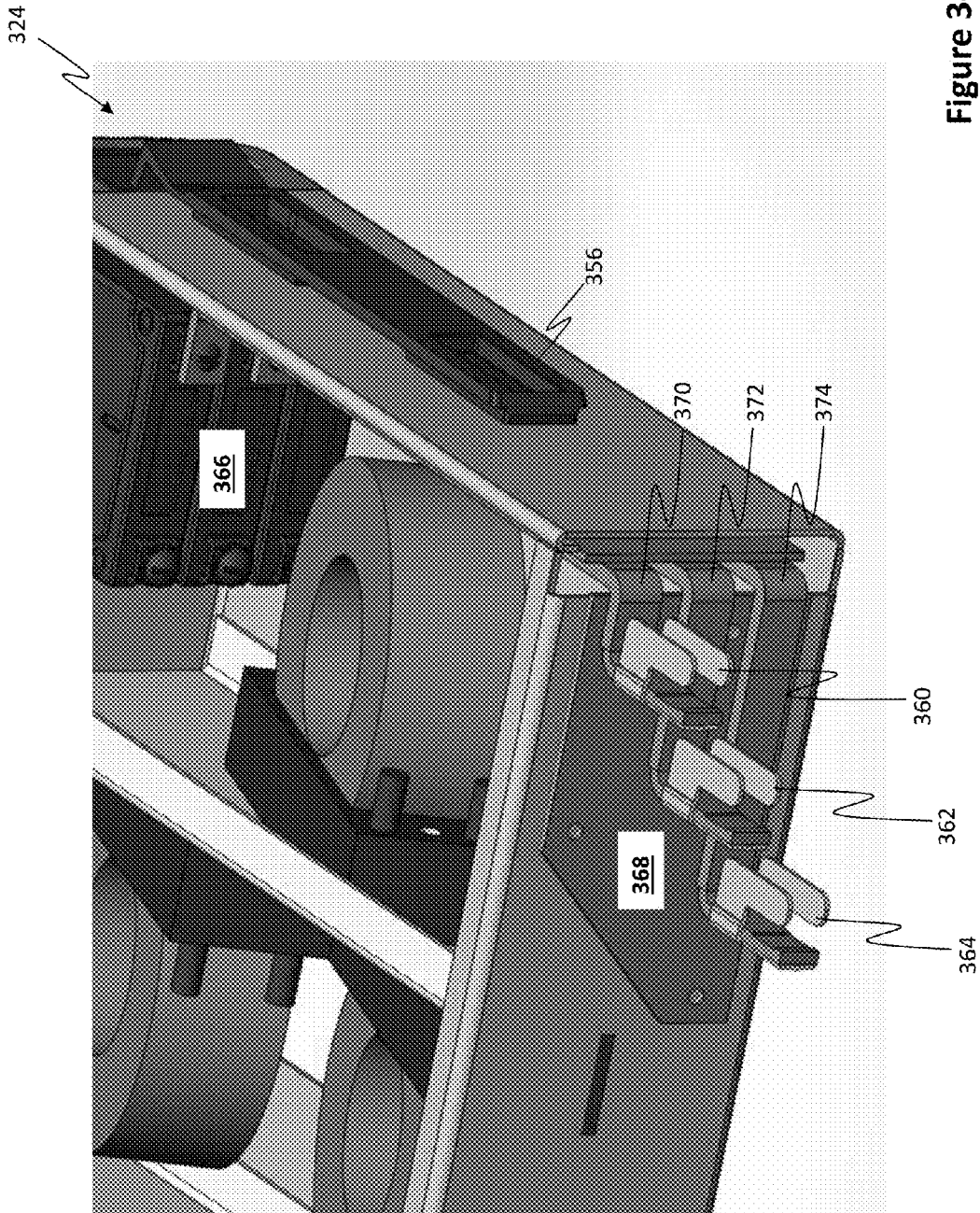

Figure 34

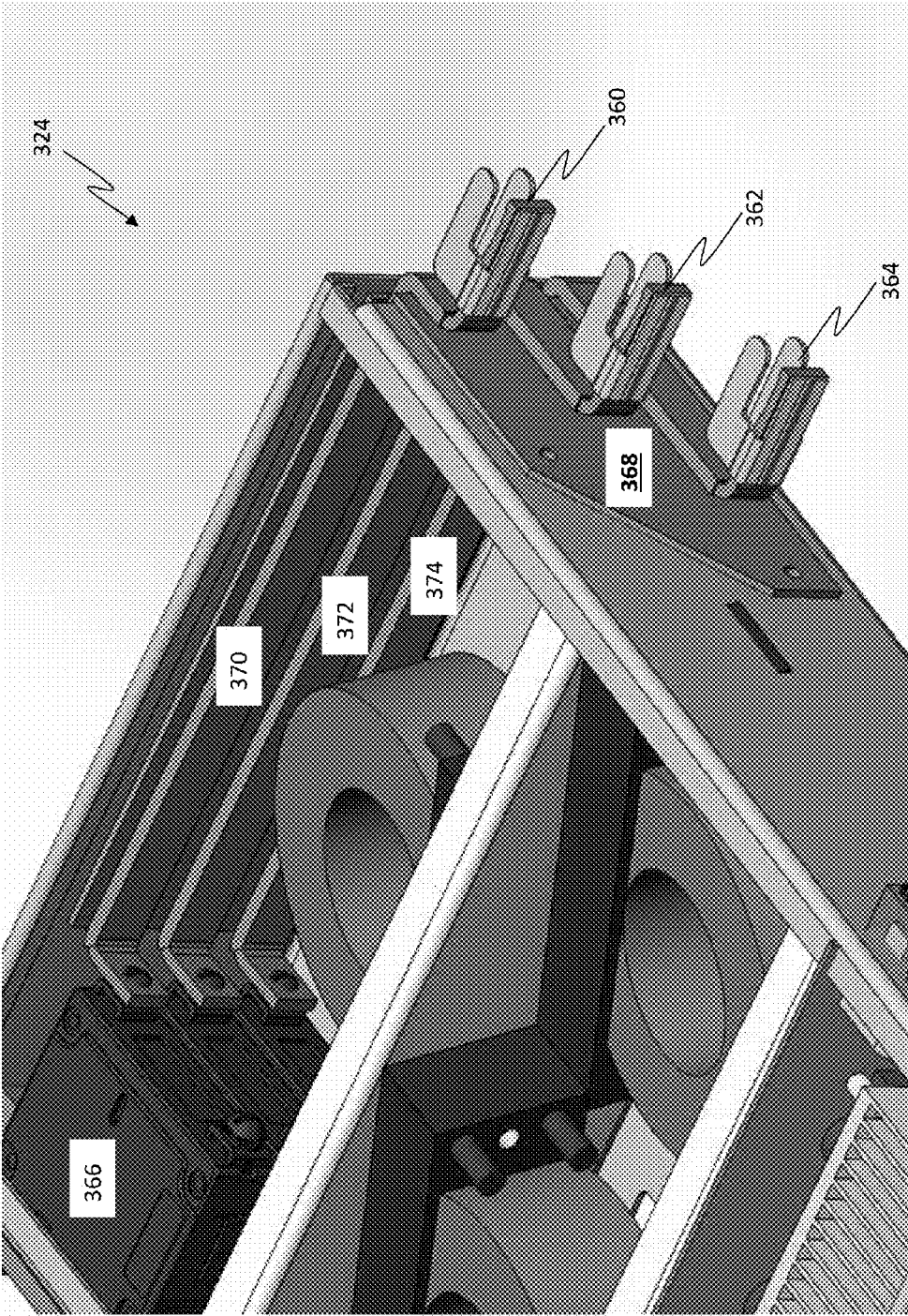

Figure 35

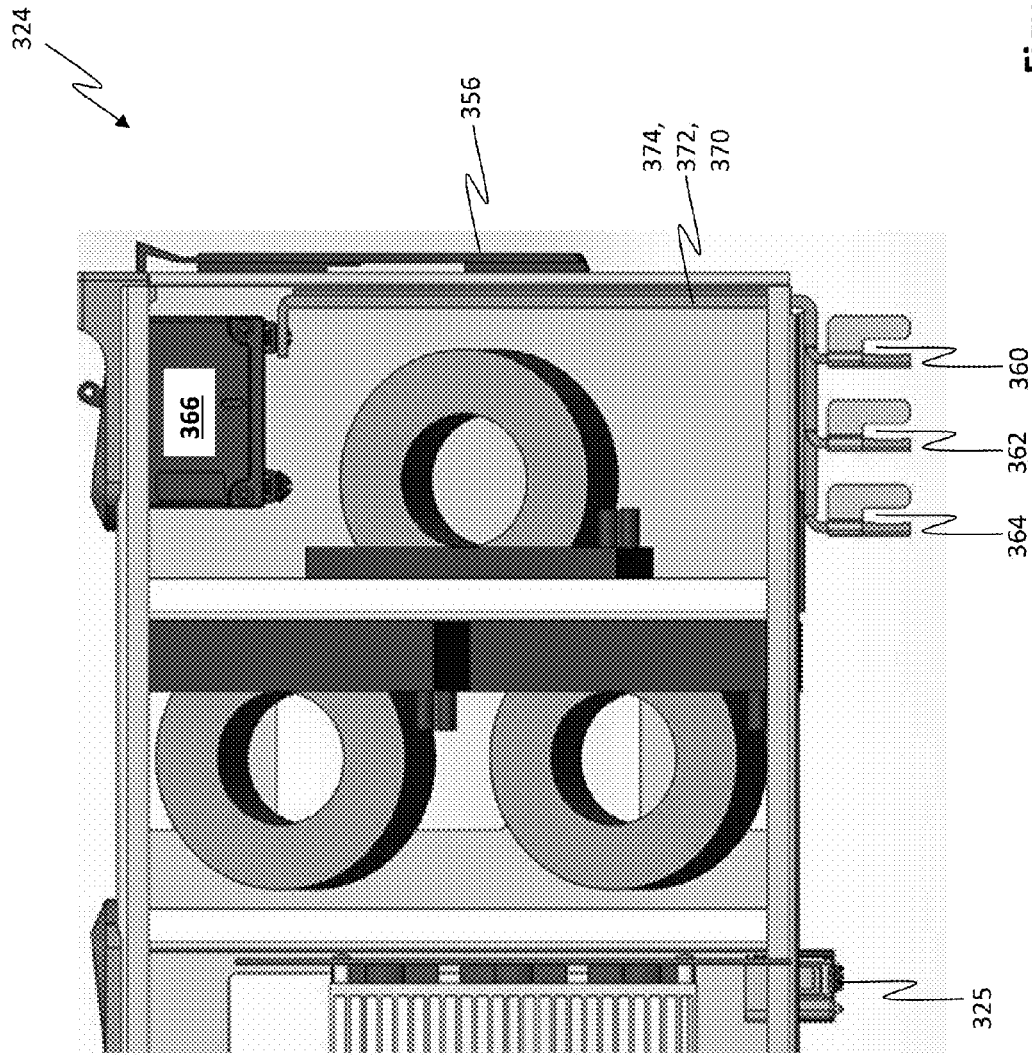

Figure 36

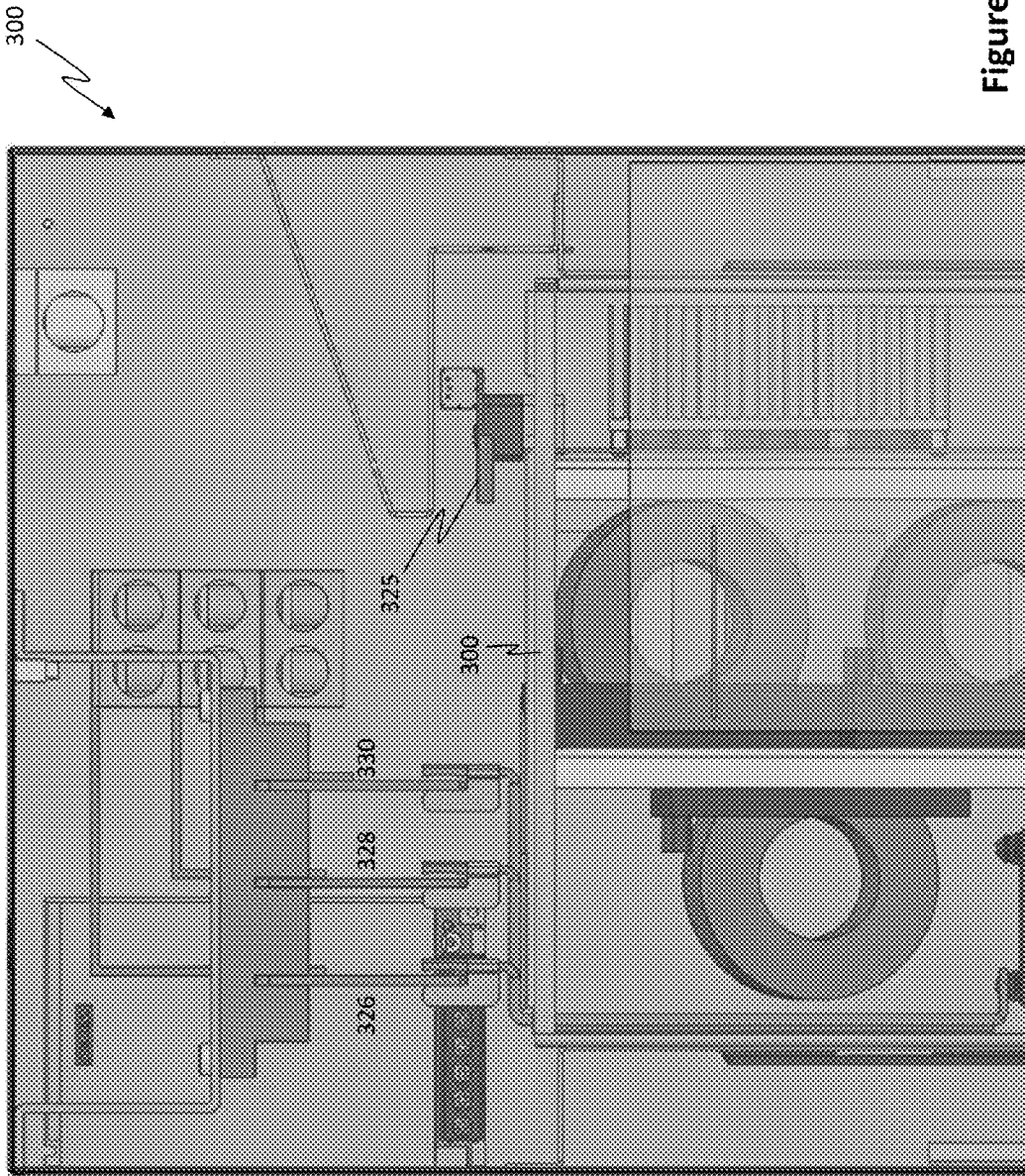

Figure 37

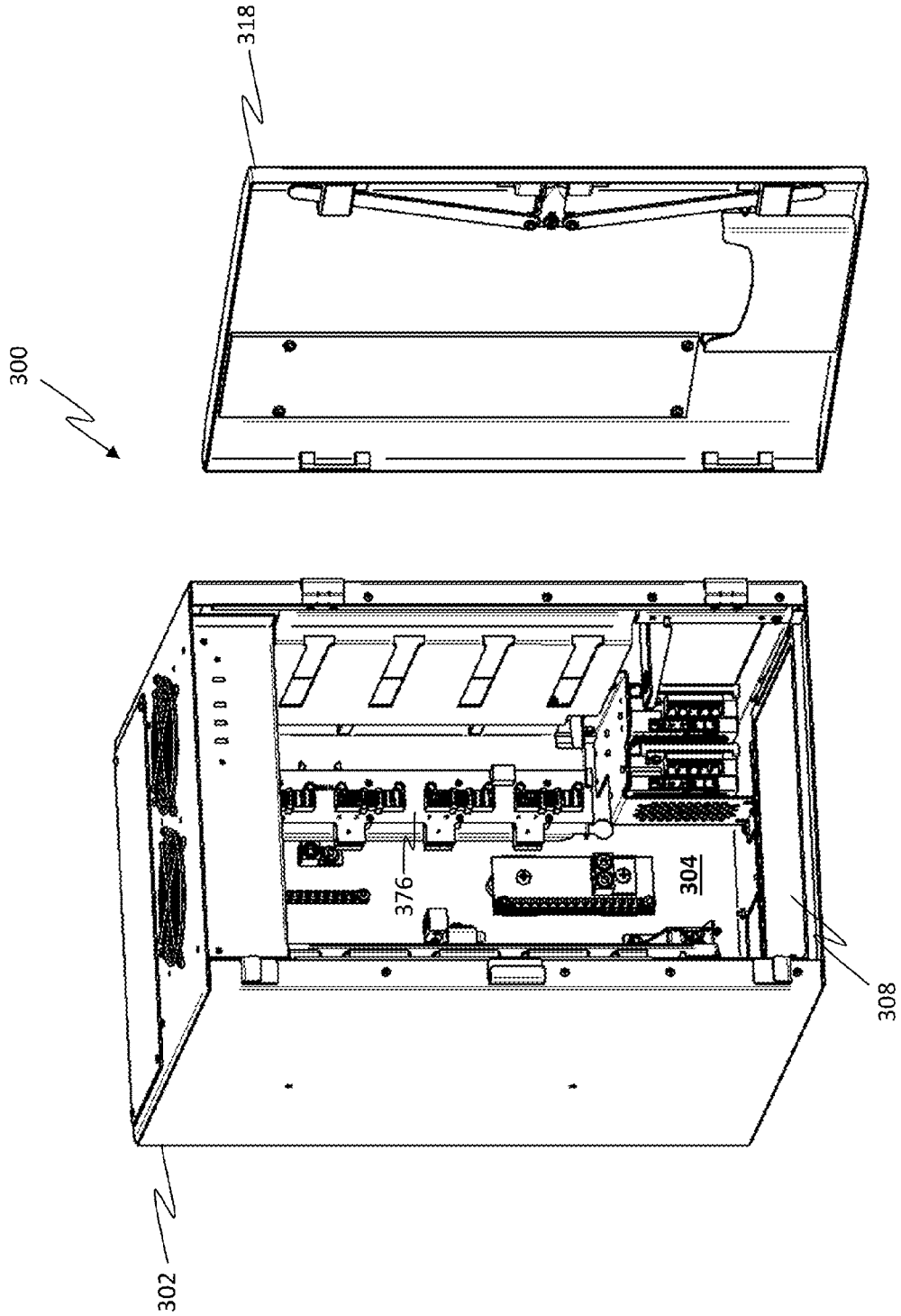

Figure 38

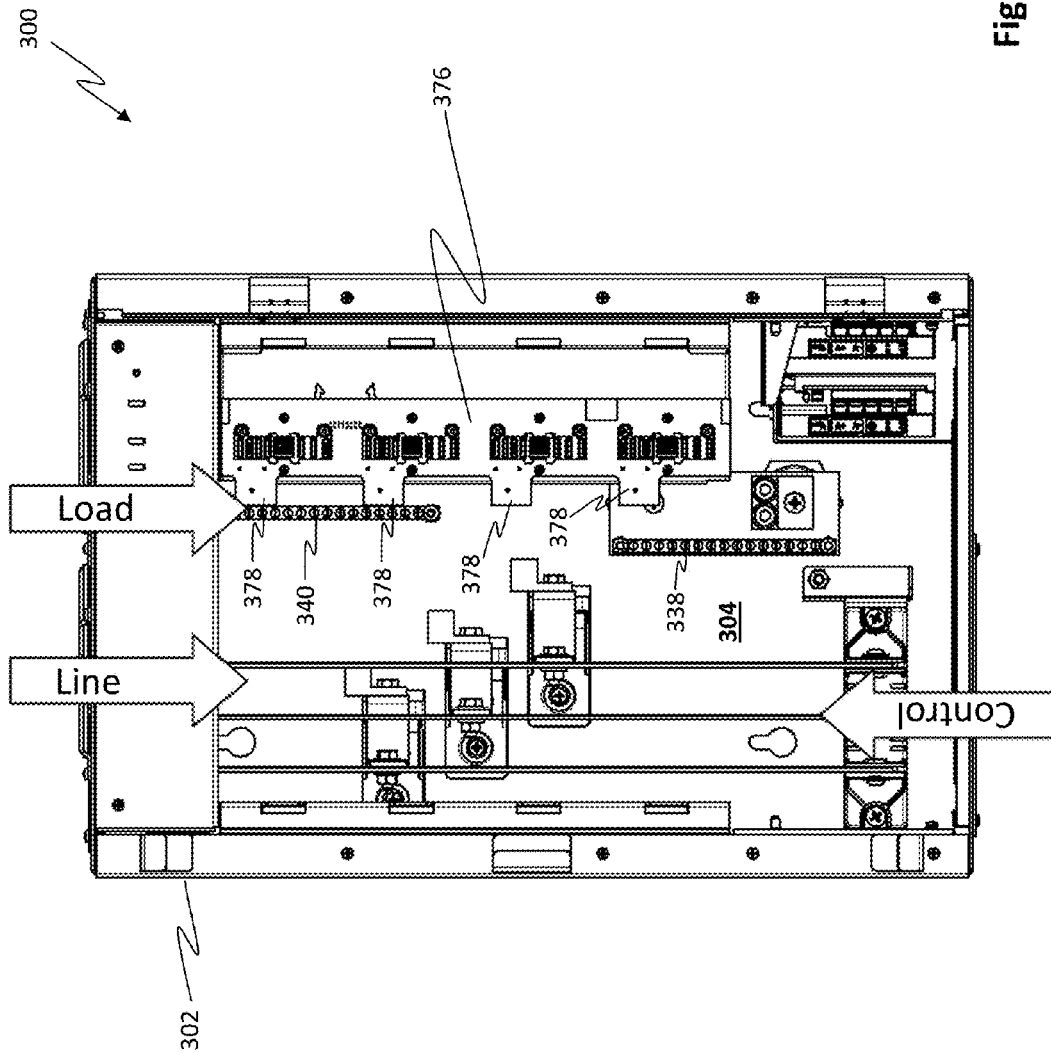

Figure 39

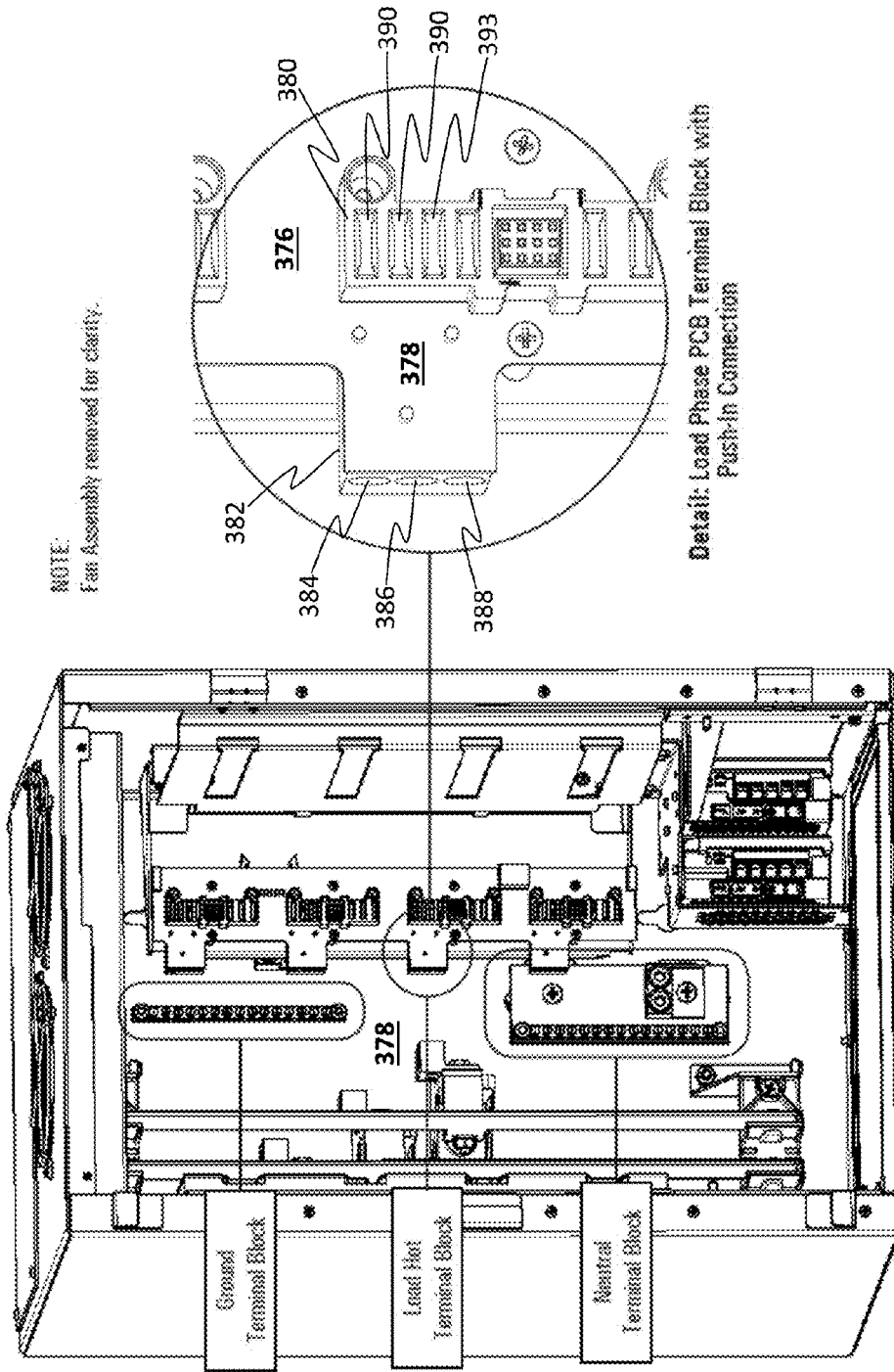

Figure 40

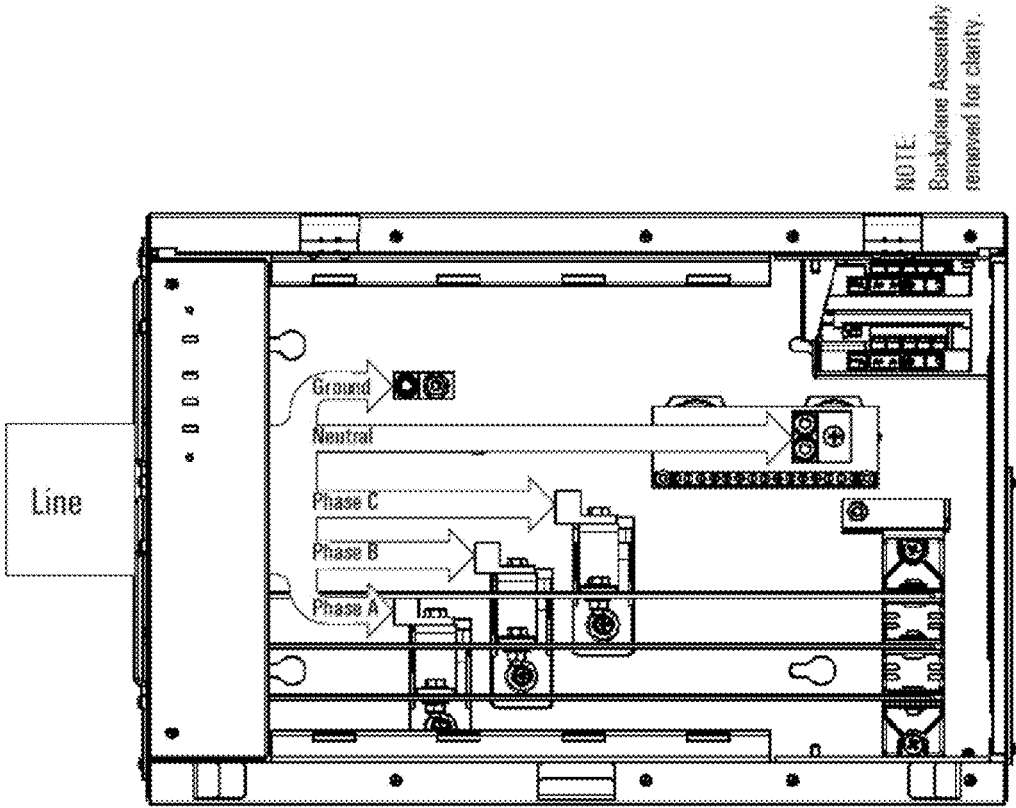

Figure 41

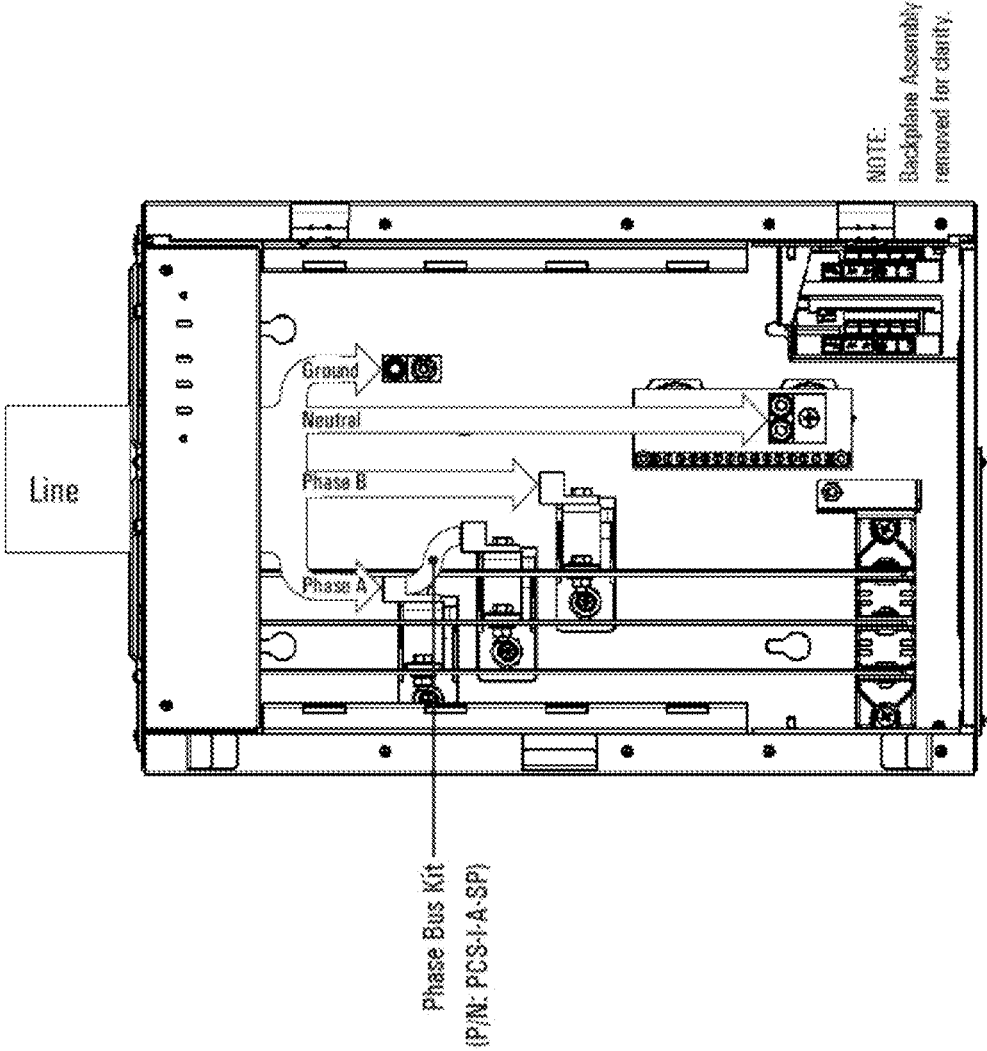
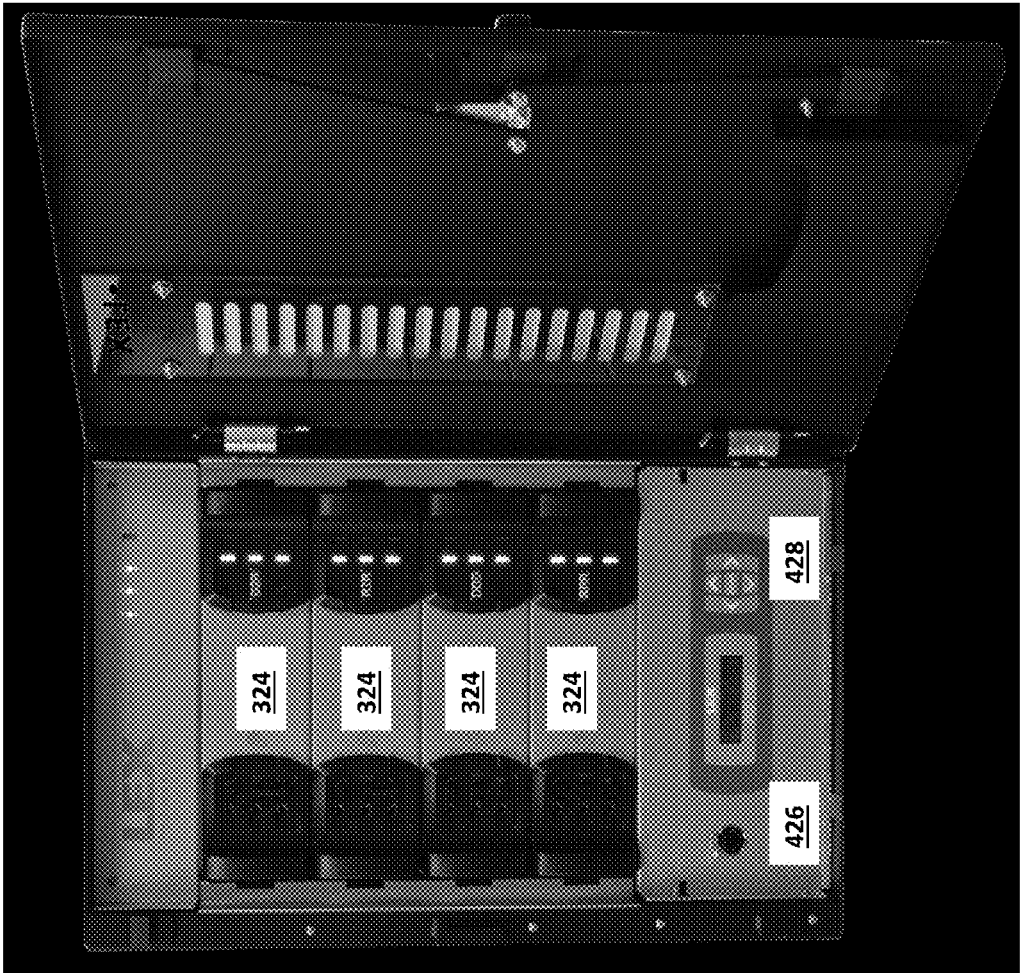

Figure 42

300 ↗



302 ↘

Figure 43

300

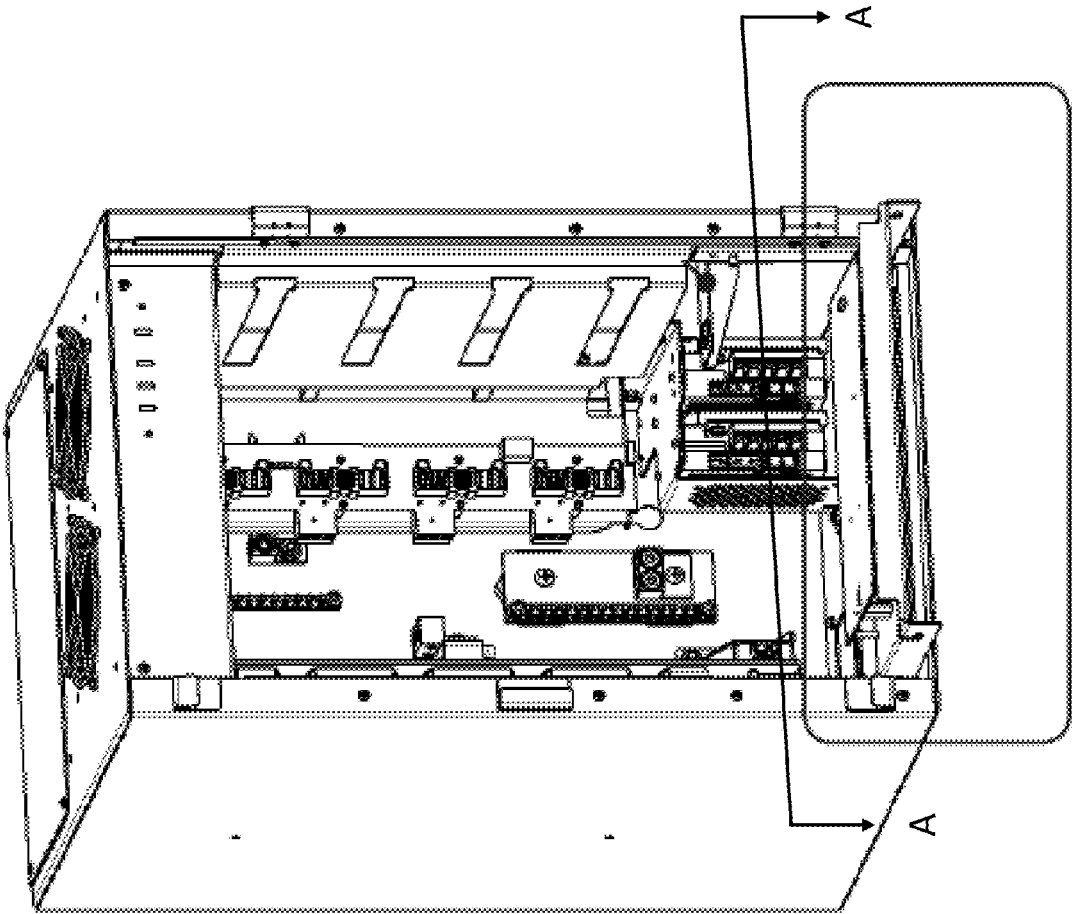

Figure 44

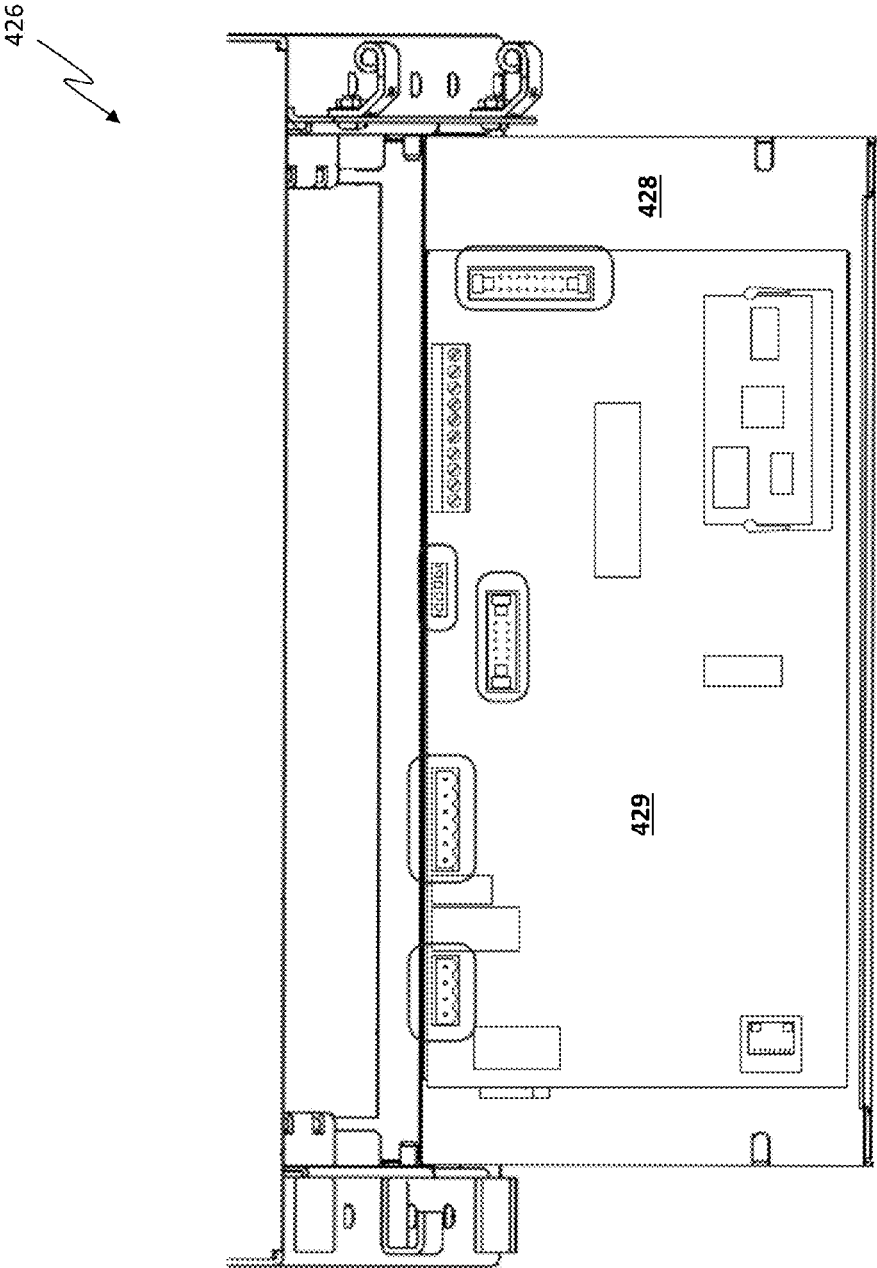

Figure 45

Section A-A

426 ↘

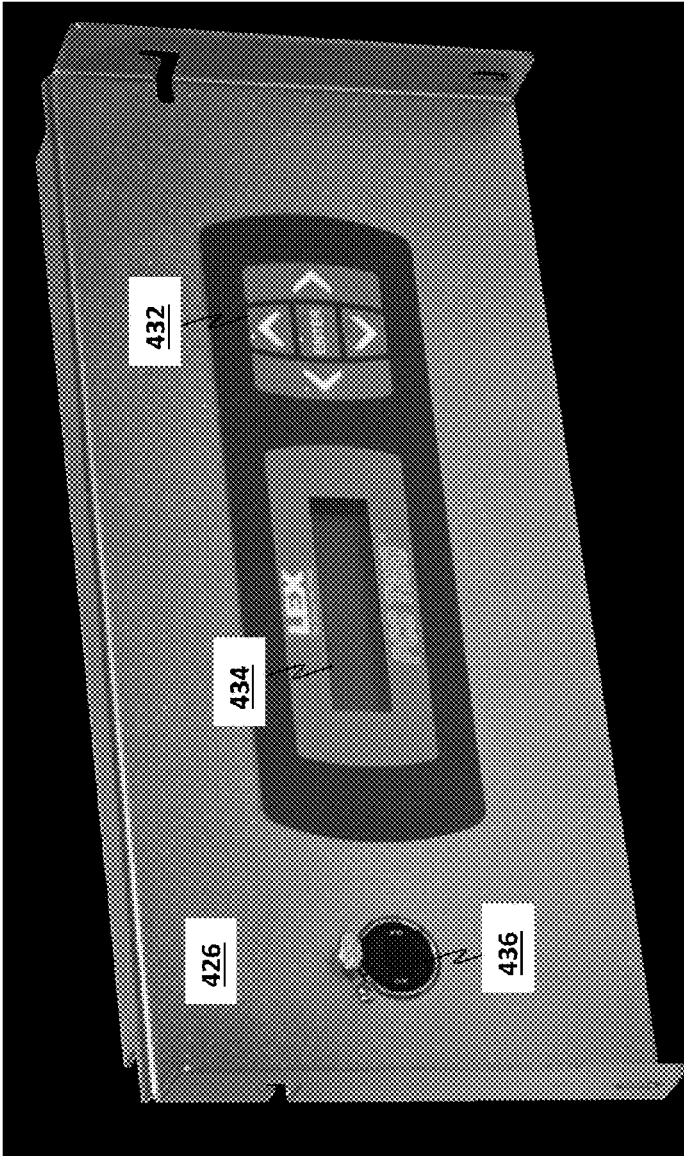

Figure 46

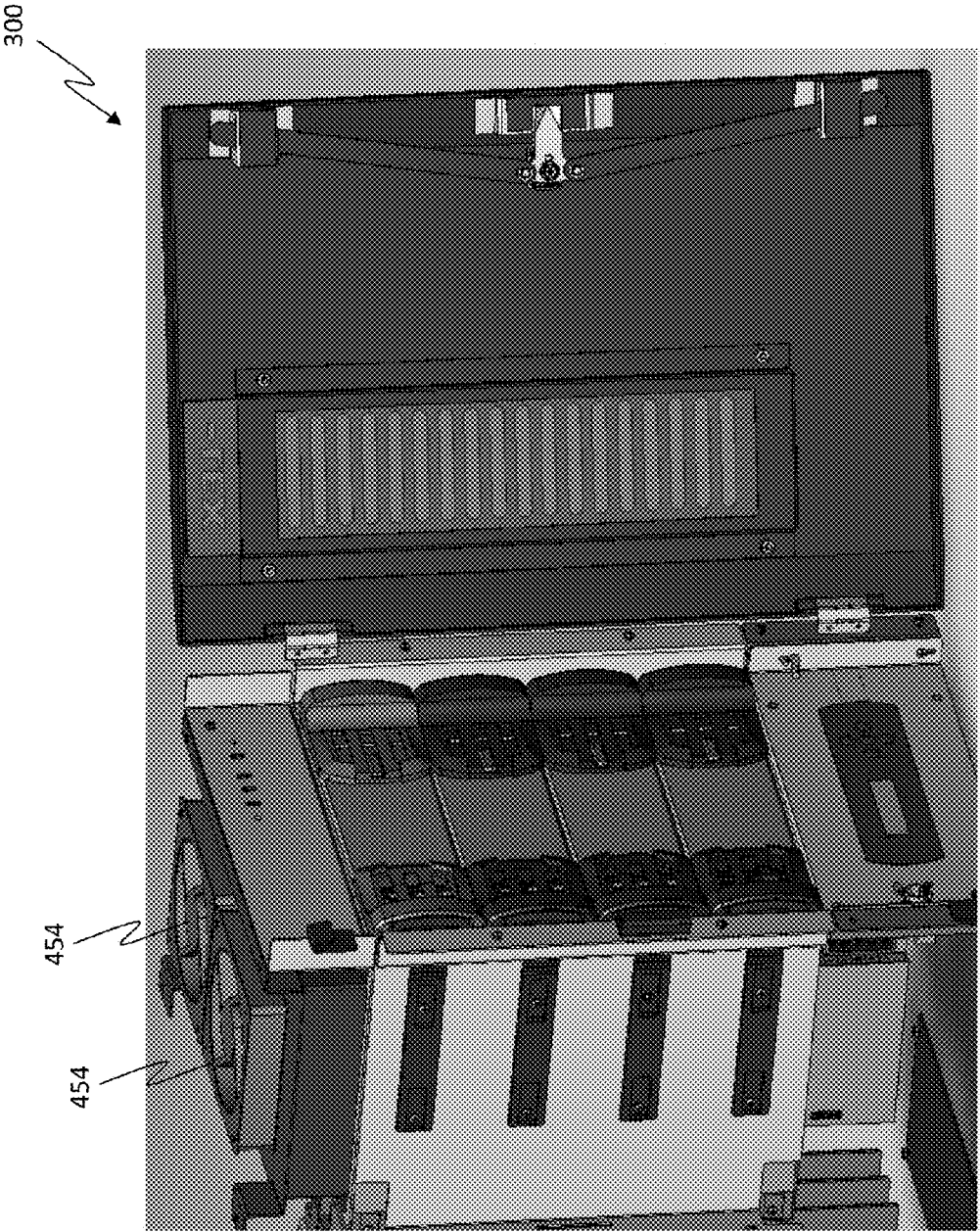

Figure 47

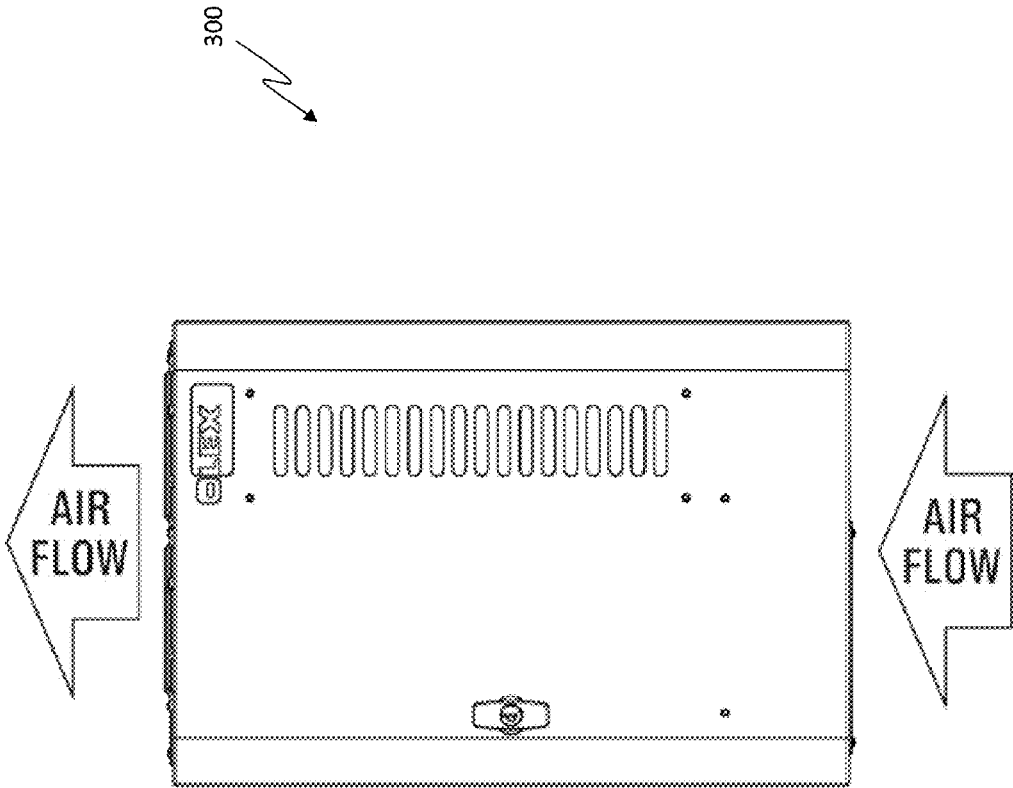

Figure 48

1

## CONFIGURABLE MODULAR POWER CONTROL SYSTEM

### RELATED APPLICATIONS

This application is a continuation-in-part application of U.S. Non-Provisional patent application Ser. No. 14/057,430 and claims the benefit of priority of U.S. Provisional Patent Application Ser. No. 62/079,620, U.S. Non-Provisional patent application Ser. No. 14/057,430 and U.S. Provisional Patent Application Ser. No. 61/715,358, the contents of all of which are incorporated by reference herein in their entireties.

### FIELD OF THE INVENTION

The present invention relates generally to a system for controlling power and more particularly to a modular power control system that is configurable to accomplish various types of power control operations such as dimmer control and single-pole/double-pole relay requirements.

### BACKGROUND OF THE INVENTION

Power control systems that control dimmer and power relay operations lighting and other devices are known in the art and are typically constructed using large enclosures that have exposed bus bars (one bus bar for each electrical phase) and other electrical connections. Moreover, the components used to accomplish the task of controlling dimmer and power relay functions are 'hardwired' into the enclosure and typically require a large amount of wiring which results in a virtual 'rats nest' of wires inside of the enclosure. Furthermore, as these systems deal with large power applications, the components used typically generate large amounts of heat.

Unfortunately however, current designs do little in the way of providing a safe environment for technicians that must work on these systems. The exposed bus bars and electrical connections create a safety hazard for people that have access the internal area of the enclosure. This is undesirable because electrocution and shock can not only occur when the components and bus bars are accidentally touch, but with high power devices such as relays, switches, circuit breakers, etc. if an individual gets to close an electric arc may occur. Accordingly, although a trained technician may have a reduced risk of electric shock, the exposed nature of the components and bus bars makes that risk more prevalent.

Additionally, the current enclosures are not designed to efficiently dissipate the heat generated by the components. Accordingly, the temperature within the enclosure typically rises to a high level and may result in failure of the components. This creates a tempting opportunity to leave the enclosure door open to help dissipate the heat. Unfortunately, this creates a furthermore safety hazard by allowing access into the system enclosure and exposing non-trained personnel to the electrical components within the enclosure.

### SUMMARY OF THE INVENTION

A modular power control system, comprising: an enclosure having an enclosure top, an enclosure bottom, an enclosure front, an enclosure rear, a first enclosure side and a second enclosure side, wherein the enclosure defines an enclosure cavity and wherein the enclosure further includes an input power connector; a module internal support,

2

wherein the module internal support includes a first module support connected to the first enclosure side and a second module support connected to the second enclosure side, wherein the first module support includes a first module channel and the second module support includes a second module channel; at least one module, wherein the at least one module includes a module rear, a module front and module sides which define a module cavity, wherein each of the module sides include a side channel guide for interacting with the first and second module channels to support the module, wherein the module includes at least one module power connector configured to conductively associate with the input power connector when the at least one module is located within the enclosure cavity.

A modular power control system, comprising: an enclosure defining an enclosure cavity, an input power Phase A bus bar, an input power Phase B bus bar, an input power Phase C bus bar; a first module support and a second module support located within the enclosure cavity and connected to the enclosure, wherein the first module support includes a first module channel and the second module support includes a second module channel; and a module, wherein the module includes a module rear, a module front and module sides, wherein each of the module sides include a side channel guide configured to slidably interacting with the first and second module channels to support the module within the enclosure cavity and wherein the module rear includes a module power Phase A connector configured to conductively mate with the input power Phase A bus bar, a module power Phase B connector configured to conductively mate with the input power Phase B bus bar and a module power Phase C connector configured to conductively mate with the input power Phase C bus bar when the module is contained within the enclosure cavity.

### BRIEF DESCRIPTION OF THE DRAWINGS

The foregoing and other features and advantages of the present invention will be better understood from the following detailed description of illustrative embodiments, taken in conjunction with the accompanying drawings in which:

FIG. 1 is a top down perspective exploded view of a Modular Power Control System (MPCS), in accordance with one embodiment of the present invention.

FIG. 2A is front isometric view of the base enclosure of the MPCS of FIG. 1.

FIG. 2B is front view of the base enclosure of the MPCS of FIG. 1.

FIG. 3A is a front perspective view of the base enclosure door of the MPCS of FIG. 1.

FIG. 3B is a rear view of the base enclosure door showing the base enclosure door cavity of the MPCS of FIG. 1.

FIG. 4A is a rear view of a power connector of the MPCS of FIG. 1 illustrating the pin configuration.

FIG. 4B is a rear view of the first and second power connectors of the MPCS of FIG. 1 illustrating the pin configuration.

FIG. 4C is a rear view of the third and fourth power connectors of the MPCS of FIG. 1 illustrating the pin configuration.

FIG. 4D is a rear view of the fifth and sixth power connectors of the MPCS of FIG. 1 illustrating the pin configuration.

FIG. 4E is a rear view of a power connector illustrating the pin configuration in accordance with an additional embodiment.

FIG. 5 is a front side isometric view of the module enclosure of the MPCPS of FIG. 1.

FIG. 6 is a front side isometric view of the module enclosure internal support of the MPCPS of FIG. 1.

FIG. 7A is top side isometric view of one embodiment of a module for use with the MPCPS of FIG. 1 illustrating an 'open' design.

FIG. 7B is top side isometric view of multiple embodiments of modules for use with the MPCPS of FIG. 1.

FIG. 7C is top side isometric view of a chimney airflow module for use with the MPCPS of FIG. 1.

FIG. 8 is top side isometric view of a dimmer module for use with the MPCPS of FIG. 1 illustrating an 'open' design.

FIG. 9 is top side isometric view of a relay (single-pole/double-pole) module for use with the MPCPS of FIG. 1 illustrating an 'open' design.

FIG. 10 is bottom up view of one embodiment of a module for use with the MPCPS of FIG. 1 illustrating an 'open' design.

FIG. 11 is a top side isometric view of the module enclosure front panel of the MPCPS of FIG. 1.

FIG. 12 is block diagram illustrating one embodiment of the PCB Backplane configured for Ethernet capability for use with the MPCPS of FIG. 1.

FIG. 13 is block diagram illustrating another embodiment of the PCB Backplane configured for DMX capability for use with the MPCPS of FIG. 1.

FIG. 14 is block diagram illustrating still yet another embodiment of the PCB Backplane configured for DMX capability for use with the MPCPS of FIG. 1.

FIG. 15 is front view of the module enclosure of FIG. 1 illustrating airflow within the module enclosure cavity.

FIG. 16 is chart illustrating some embodiments of various sizes of the MPCPS of FIG. 1.

FIG. 17 is a front side view of a Modular Power Control System (MPCPS), in accordance with another embodiment of the invention.

FIG. 18 is a top front side view of the MPCPS of FIG. 17.

FIG. 19 is rear view of the MPCPS of FIG. 17.

FIG. 20 is a top down view of the MPCPS of FIG. 17.

FIG. 21 is a bottom up view of the MPCPS of FIG. 17.

FIG. 22A is a front view of the MPCPS of FIG. 17 showing the enclosure cavity.

FIG. 22B is a top down side perspective view of the input power bus bars used in the MPCPS of FIG. 17, in accordance with one embodiment of the invention.

FIG. 23 is a front view of a module for use in the MPCPS of FIG. 17, in accordance with one embodiment of the invention.

FIG. 24 is a rear view of the module of FIG. 23.

FIG. 25 is a top down view of the module of FIG. 23 illustrating the module cavity.

FIG. 26 is a top down perspective view of the module of FIG. 23 illustrating the module cavity.

FIG. 27 is a side view of the module of FIG. 23.

FIG. 28 is a top down view of a module for use in the MPCPS of FIG. 17 illustrating the module cavity, in accordance with another embodiment of the invention.

FIG. 29 is a top down perspective view of the module of FIG. 28 illustrating the module cavity.

FIG. 30 is a top down view of a module for use in the MPCPS of FIG. 17 illustrating the module cavity, in accordance with still yet another embodiment of the invention.

FIG. 31 is a top down perspective view of the module of FIG. 30 illustrating the module cavity.

FIG. 32 is a top down view of a module for use in the MPCPS of FIG. 17 illustrating the module cavity, in accordance with still yet another embodiment of the invention.

FIG. 33A is a top down perspective view of the module of FIG. 32 illustrating the module cavity.

FIG. 33B is chart illustrating some embodiments of various power inputs of the MPCPS of FIG. 17.

FIG. 34 is left side rear perspective view of one embodiment of a module for use with the MPCPS of FIG. 17 illustrating the module input power connectors, in accordance with one embodiment of the invention.

FIG. 35 is right side rear perspective view of the module of FIG. 34 illustrating the module input power connectors.

FIG. 36 is a top down view of the module of FIG. 34 illustrating the module cavity.

FIG. 37 is a top down sectional view of the MPCPS and the module of FIG. 34 located within the enclosure cavity and connected to the input power bus bars of FIG. 22B.

FIG. 38 is a partially exploded front side view of the MPCPS of FIG. 17 illustrating the enclosure cavity.

FIG. 39 is a front view of the MPCPS of FIG. 17 illustrating the input power bus bars and the terminal backplane located within the enclosure cavity.

FIG. 40 is a front view of the MPCPS of FIG. 17 illustrating the terminal backplane located within the enclosure cavity and an exploded view of a terminal block, in accordance with one embodiment of the invention.

FIG. 41 is a front view of the MPCPS of FIG. 17 illustrating the input power bus bars configured for three-phase operation, in accordance with one embodiment of the invention.

FIG. 42 is a front view of the MPCPS of FIG. 17 illustrating the input power bus bars configured for single-phase operation, in accordance with one embodiment of the invention.

FIG. 43 is a front view of the MPCPS of FIG. 17.

FIG. 44 is a front view of the MPCPS of FIG. 17 illustrating the MPCPS controller front panel and showing the controller backplane.

FIG. 45 is a rear view of the controller front panel of FIG. 44 showing the controller backplane, in accordance with one embodiment of the invention.

FIG. 46 is front view of the controller front panel of the MPCPS of FIG. 17, in accordance with one embodiment of the invention.

FIG. 47 is a front side view of the MPCPS of FIG. 17 with the system enclosure removed showing the cooling fans, in accordance with one embodiment of the invention.

FIG. 48 is front view of the MPCPS of FIG. 17 illustrating airflow into and out of system enclosure, in accordance with one embodiment of the invention.

#### DETAILED DESCRIPTION OF THE INVENTION

It should be appreciated that although the modular power distribution system of the present invention is described herein in terms of a dimmer array system, the concept of the invention may be used for any situation that requires power to be distributed. It should also be appreciated that the present invention may be a portable or permanently installed unit configurable for operation with single and multiple phase applications of up to 200 A (and in some cases greater than 200 A), such as power distribution application for LEDs, moving lights, traditional dimming, etc.

Referring to FIG. 1, a Modular Power Control System (MPCPS) 100 is shown and includes a base enclosure 102, a

base enclosure door **104**, a module enclosure **106**, a module enclosure internal support **108** and a module enclosure front panel **110**.

Referring to FIG. 2A and FIG. 2B, the base enclosure **102** includes a base enclosure front **112**, a base enclosure back **114**, a base enclosure top **116**, a base enclosure bottom **118** and two base enclosure sides **120**, wherein the base enclosure front **112**, base enclosure back **114**, base enclosure top **116**, base enclosure bottom **118** and base enclosure sides **120** define a base enclosure cavity **122**. Additionally, the base enclosure front **112** includes a base enclosure opening **124** which allows access into the base enclosure cavity **122**. Referring to FIG. 3A and FIG. 3B, the base enclosure door **104** includes a base enclosure door front **126**, a base enclosure door back **128**, a base enclosure door top **130**, a base enclosure door bottom **132** and two base enclosure door sides **134**, wherein the base enclosure door front **126**, base enclosure door back **128**, base enclosure door top **130**, base enclosure door bottom **132** and base enclosure door sides **134** define a base enclosure door cavity **136**. Additionally, the base enclosure door back **128** includes a base enclosure door opening **138** which allows access into the base enclosure door cavity **136**. The base enclosure door also includes a plurality of power connector openings **140** and a plurality of signal connector openings **142**.

It should be appreciated that the base enclosure door **104** is attached to the base enclosure **102** via a hinge **144** such that the base enclosure door **104** is rotatable between an open configuration and a closed configuration. When in the open configuration, the base enclosure cavity **122** and base enclosure door cavity **136** are accessible. When in the closed configuration, the base enclosure door back **128** aligns with the base enclosure front **112** to enclose the base enclosure cavity **122**/base enclosure door cavity **136** and such that the base enclosure opening **124** and base enclosure door opening **138** are proximate each other. A base enclosure locking member may be included on at least one of the base enclosure **102** and the base enclosure door **104** to limit access to the base enclosure cavity **122** and the base enclosure door cavity **136**.

Referring again to FIG. 2A and FIG. 2B, the MPC **100** also includes a power input opening **150**, a power supply **152**, a Phase A power input terminal **154**, a Phase B power input terminal **156**, a Phase C power input terminal **158**, a power output distribution block **160**, a ground terminal **162** and a neutral terminal **164**, wherein the power supply **152**, Phase A power input terminal **154**, Phase B power input terminal **156**, Phase C power input terminal **158**, power output distribution block **160**, ground terminal **162** and neutral terminal **164** are securely located within the base enclosure cavity **122**. Additionally, referring again to FIG. 3A and FIG. 3B, the MPC **100** also includes a plurality of power connectors **166**, a plurality of signal connectors **168** and PCB Backplane **170** which are located within the base enclosure door cavity **136**. The plurality of power connectors **166** are associated with the plurality of power connector openings **140** and the plurality of signal connectors **168** are associated with the plurality of signal connector openings **142** such that the interface portion of the plurality of power connectors **166** and signal connectors **168** are accessible via the base enclosure door front **126**. It should be appreciated that the number of power connectors **166** and signal connectors **168** may be dependent on the number of modules that the MPC **100** can accommodate. Additionally, referring to FIG. 4A each of the power connectors **166** include a

first power input port **172**, a first power output port **174**, a second power input port **176** and a second power output port **178**.

It should be appreciated that the three-phase power is introduced into the MPC **100** via the power input opening **150** and includes a Phase A conductor that is connected to the Phase A power input terminal **154**, a Phase B conductor that is connected to the Phase B power input terminal **156** and a Phase C conductor that is connected to the Phase C power input terminal **158**. The three-phase power also includes a neutral conductor that is connected to the neutral terminal **164** and a ground conductor that is connected to the ground terminal **162**. Additionally, the power supply **152** may be powered via the three-phase power by connecting the power input of the power supply **152** to at least one of the Phase A power input terminal **154**, Phase B power input terminal **156** or Phase C power input terminal **158**.

Referring to FIG. 4B, FIG. 4C and FIG. 4D, one embodiment of the connection of the power phases to the plurality of power connectors **166** is illustrated. As shown, the MPC **100** is configured to accommodate six (6) modules and thus includes a first power connector **180**, a second power connector **182**, a third power connector **184**, a fourth power connector **186**, a fifth power connector **188** and a sixth power connector **190**. The first power connector **180** is configured to have a Phase A power input and output and a Phase B power input and output, the second power connector **182** is configured to have a Phase C power input and output and a Phase A power input and output, the third power connector **184** is configured to have a Phase B power input and output and a Phase C power input and output, the fourth power connector **186** is configured to have a Phase A power input and output and a Phase B power input and output, the fifth power connector **188** is configured to have a Phase C power input and output and a Phase A power input and output and the sixth power connector is configured to have a Phase B power input and output and a Phase C power input and output. It should be appreciated that the phase power inputs of the plurality of connectors **166** are connected to the appropriate Phase power input terminal and the phase power outputs of the plurality of connectors **166** are connected to the power output distribution block **160** for distribution to external loads. The signal connectors **168** are connected to the PCB Backplane **170**. Moreover, power conductors from the power supply **152** are also connected to the PCB Backplane **170** to provide power to the PCB Backplane **170**.

It should be appreciated that various types of power connectors **166** may be used in response for different configurations. For example, the power connectors **166** may vary from a four (4) pin configuration (See FIG. 4A) and may include a six (6) (or more) pin connector **167** (See FIG. 4E). In this embodiment, the six (6) pin connector **167** includes pins for two phases, where each phase includes a power phase output pin, a power phase input pin and a neutral pin. Other connector configurations are also contemplated and are responsive to the application.

Referring to FIG. 5, the module enclosure **106** includes a module enclosure front **192**, a module enclosure rear **194**, a module enclosure top **196**, a module enclosure bottom **198** and two module enclosure sides **200**, wherein the module enclosure rear **194**, module enclosure top **196**, module enclosure bottom **198** and module enclosure sides **200** define a module enclosure cavity **202**. Additionally, the module enclosure rear **194** includes a module enclosure rear opening **204** and the module enclosure front **192** includes a module enclosure front opening **206** to allow access to the module

enclosure cavity **202** from both the module enclosure front **192** and the module enclosure rear **194**. Referring to FIG. 6, the module enclosure internal support **108** includes a module enclosure internal support rear **208** and two module enclosure internal support sides **210**, where the module enclosure internal support rear **208** includes an internal support opening **212**. The module enclosure internal support **108** is securely located within the module enclosure cavity **202** such that the internal support opening **212** is aligned with the module enclosure rear opening **204**. It should be appreciated that the module enclosure internal support **108** is securely attached to the module enclosure rear **194** and/or the module enclosure sides **200** via screws. The module enclosure internal support **108** further includes a plurality of module guide channel pairs **214**, where one of the channels of the module guide channel pair **214** is located on one side of the module enclosure internal support sides **210** and the other of the channel of the module guide channel pair **214** is located on the other side of the module enclosure internal support sides **210**. These module guide channel pairs **168** are configured to slidably receive and contain a module **216** within the module enclosure **106**, where one channel of the module guide channel pairs **214** include a resilient member **218** which interacts with the module **216** as discussed further hereinafter to lockingly and securely contain the module **216** within the module guide channel pair **214**.

Referring to FIG. 7A and FIG. 7B, one embodiment of the module **216** is shown and includes a module housing **220** having a module housing front **222**, a module housing rear **224** and module housing sides **225**, wherein the module housing front **222**, module housing rear **224** and module housing sides **225** define a module housing cavity **227** for containing module components. It should be appreciated that the module components are dependent upon the function of the module **216**. For example, in one embodiment referring to FIG. 8 if the module **216** is a dimmer module, then the module **216** may contain dimmer power components (such as two (2) or more SCR 120V 10 A dimmers) as well as dimmer control circuitry. In another embodiment, referring to FIG. 9 if the module **216** is a relay module, then the module **216** may contain single-pole (such as two (2) Single-Pole 20 A 120V relays) or double-pole (such as one (1) Double-Pole 20 A 220V relay) relays as well as relay control circuitry/switches. It is contemplated that the modular power control system (MPCS) **100** may include any mix of different type modules **216**. For example, although the MPCS **100** is described herein as using relay and dimmer modules, any type of modules that may be used for power distribution applications (i.e. for architectural, entertainment, etc.) may be used, such as modules that provide power and control of fluorescent ballasts and various other dimming techniques. Also, the modules may be used for power distribution and control to various other types of electronic/electrical equipment. It should be appreciated that the present invention advantageously provides access to all power phases as desired without having to reconfigure the entire system.

Additionally, referring to FIG. 7C, it should be appreciated that module **216** may be configured as a chimney airflow module **217**, where the module housing cavity **227** is left unpopulated and substantially free of obstruction. The configuration of the chimney airflow module **217** advantageously acts as a flow path guide to direct airflow between the module enclosure bottom **198** and the module enclosure top **196**. This is discussed in further detail hereinafter.

Furthermore, the module housing cavity **227** may be divided into a front cavity portion **230** and a rear cavity

portion **232**. The module housing sides **225** include a side channel guide **234** that is configured (i.e. size and shape) to slidably and supportingly interact with the module guide channel pair **214**, where the side channel guide **234** on one module housing side **225** fits into one of the channels of the module guide channel pair **214** and the side channel guide **234** on the other module housing side **225** fits into the other of the channels of the module guide channel pair **214**. It should be appreciated that one (or more) of the side channel guides **234** are sized such that when the side channel guides **234** are contained within the module guide channel pair **214**, the resilient member **218** prevents the module **216** from being removed from the module guide channel pair **214**. When the resilient member **218** is compressed, the module **216** may be removed from the module guide channel pair **214**.

Moreover, referring to FIG. 10, the module housing rear **224** includes a module housing power connector **226** for providing input and output phase power to and from the module **216** and a module housing signal connector **228** for providing control signals to and from the module **216**. The module housing power connector **226** is configured to mate with a power connector of the plurality of power connectors **166** and the module housing signal connector **228** is configured to mate with a signal connector of the plurality of signal connectors **168**. As discussed further hereinafter, in one embodiment there is a power connector **166** and a signal connector **168** for each of the modules **216** and the power connector **166** and signal connector **168** are located on the base enclosure door front **126**, such that when the module **216** is located within the module enclosure **106**, the power connector **166** is mated to and connected with the module housing power connector **226** and the signal connector **168** is mated to and connected with the module housing signal connector **228**.

It should be appreciated one advantage of the present invention involves the physical distribution of the phases (Phase A, Phase B, Phase C) to the power connectors **166** (See FIG. 4A-FIG. 4D) which advantageously allows availability of and access to multiple phases for applications (via the module **216**) that use single or multiple phases (for example, single-pole or double-pole devices). Accordingly, while the invention is discussed herein as being used with dimmers and relays, a module of any functionality that incorporates single-pole or double-pole devices can be used with the present invention.

Referring to FIG. 11, the module enclosure front panel **110** is shown and includes a module enclosure front panel front **236**, a module enclosure front panel rear **238** and a module enclosure front panel opening **240**. The module enclosure front panel **110** is configured to securely associate with the module enclosure front **192** such that when modules **216** are located within the module enclosure **106** (i.e. within the module guide channel pairs **214**) the module housing front **222** is accessible to allow circuit breaker switches to be turned on and off.

It should be appreciated that the PCB Backplane **170** may be a modular PCB that includes circuitry to connect the Modules **216** together and to supply power and to provide DMX/RDM and external control trigger capabilities. Referring to FIG. 12, one embodiment of the PCB Backplane **170** which is configured for use with network capability (sACN and ArtNET) is shown. Referring to FIG. 13, another embodiment of the PCB Backplane **170** which is configured for use with DMX/RDM ("daisy chain") capability is shown. Referring to FIG. 14, still yet another embodiment of the PCB Backplane **170** which is configured for use with

DMX/RDM and External Trigger Arrangement capability is shown. Additionally, other PCB Backplanes may be used that are configured for use with sACN and ArtNET protocols.

Accordingly, the present invention allows for multiple levels of control. For example, in one configuration control may be accomplished using Streaming ACN or ArtNet and provides a full range of feedback and control abilities, such as providing amperage, temperature and lamp hours and the ability to check the status of any channel in any module in any panel in the system. In another configuration control may be provided using DMX or RDM and may provide the ability to check the status of any channel 'downstream' of the plug-in point. Additionally, all of the modules/devices used in the MPCs 100 may be UL924-compliant devices.

In accordance with one embodiment of the present invention, the MPCs 100 (which may a self support structure or may be mounted to a structure) may be assembled as follows. The base enclosure 102 is obtained and the power supply 152, Power Phase input terminals 154, 156, 158, power output distribution block 160, neutral terminal 164 and ground terminal 162 are secured within the base enclosure cavity 122. This may be accomplished via any method suitable to the desired end purpose such as screws, adhesive, clips, etc. Three-phase power conductors are introduced into the base enclosure cavity 122 via an opening (not shown) where the Phase A conductor is connected to the Phase A input terminal 154, the Phase B conductor is connected to the Phase B input terminal 156 and the Phase C conductor is connected to the Phase C input terminal 158. Additionally, the neutral conductor of the input power is connected to the neutral terminal 164 and the ground conductor of the input power is connected to the ground terminal 162. The power supply may be powered by the input power by connecting the power lead of the power supply to one of the Phase input terminals 154, 156, 158. Additionally, the base enclosure door 104 is obtained and the plurality of power connectors 166 (where the number of power connectors 166 being used is dependent upon the number of modules the system can accommodate) are secured to the base enclosure door 104 such that the mating portion of the power connectors are protruding through the plurality of power connector openings 140 such that the mating portion of the power connectors are accessible via the base enclosure door front 126. The PCB Backplane 170 is connected to the base enclosure door 104 to be located within the base enclosure door cavity 136 such that the plurality of signal connectors 168 are protruding from the plurality of signal connector openings 142.

The base enclosure door 104 is connected to the base enclosure 102 (such that the base enclosure opening 124 is proximate to the base enclosure door opening 138) via a hinge 144 which allows the base enclosure door 104 to rotate between a closed configuration (where the base enclosure door 104 covers and encloses the base enclosure cavity 122) and an open configuration (where the base enclosure door 104 is rotated away from the base enclosure 102). A locking device (not shown) may be provided to secure and/or lock the base enclosure door 104 in the closed configuration to limit and/or prevent access to the base enclosure cavity 122 for safety and/or security purposes. It should be appreciated that the locking device may be any type of locking device suitable to the desired end purpose, such as a lock/catch combination or the locking device may simply be one or more screws that secure the base enclosure door 104 to the base enclosure 102. The power phases at each of the Phase input terminals 154, 156, 158 are then connected to the power input pins of the power connectors 166 to be config-

ured as shown in FIG. 4B, FIG. 4C and FIG. 4D and the output pins of the power connectors 166 are connected to the power output distribution block 160. Moreover, the power from the power supply 152 is connected to the PCB Backplane 170. The base enclosure door 104 is then configured into the closed configuration to enclose and isolate the base enclosure cavity 122 and the base enclosure door cavity 136 from the external environment. This configuration advantageously secures the base enclosure cavity 122 and the base enclosure door cavity 136 from unwanted access but also provides a high degree of safety by preventing unintended contact with high power components.

The module enclosure 106 is securely mounted to the base enclosure door 104 such that that the module enclosure rear opening 204 is adjacent the base enclosure door front 126. Guide pins may be provided on the on the base enclosure door front 126 and guide holes may be provided on the module enclosure rear 194 to help position the module enclosure 106 for mounting. It should be appreciated that the module enclosure rear opening 204 allows access to the plurality of power connectors 166 and plurality of signal connectors 168 via the module enclosure front opening 206. The module enclosure internal support 108 is located within the module enclosure cavity 202 and mounted to the module enclosure sides 200 and/or module enclosure rear 194. The module enclosure 106 may be secured to the base enclosure door 104 and the module enclosure internal support 108 may be secured to the module enclosure 106 via any device or method suitable to the desired end purpose, such as screws, clips, adhesive, etc. It should be appreciated that the design of the module enclosure 106 and module enclosure internal support 108 allow for the module enclosure cavity 202 to be substantially open. It should be further appreciated that one or more airflow fans 242 (powered by the power supply 152) may be mounted (via screw, clip, adhesive, etc.) on the module enclosure bottom 198 under the modules 216 and vent openings 244 may be included on the module enclosure top 196. Additionally, it should be appreciated that the chimney airflow module 217 may be associated with the module enclosure internal support 108 to be located proximate the module enclosure bottom 198.

Referring to FIG. 15, this configuration advantageously creates and functions as a "heat chimney" within the module enclosure, with the chimney airflow module 217 directing the air flow from the airflow fans 242 upward toward the modules 216 and out of the vent openings 244. Additionally, the modules 216 are configured as an 'open' design (See FIG. 7A) where the top and bottom of the module 216 is open (or includes openings) to accommodate airflow through the module 216 to flow between the top of the module 216 and the bottom of the module 216. This advantageously allows the airflow to contact the components within the module 216 and thus any heat generated from the module component is directed up and out of the module enclosure 106 via the vent openings 244. It should be appreciated that the Modular Power Control System (MPCS) 100 may or may not include (one or more) chimney airflow modules 217 as desired. For example, in a Modular Power Control System (MPCS) 100 which is filled with modules 216 a chimney airflow module 217 may not be used. Moreover, in a Modular Power Control System (MPCS) 100 which is not completely filled with modules 216, the empty module locations may be kept empty as desired.

At this point, one or more modules 216 may be located within the module enclosure 106 by inserting the side channel guides 234 of the module 216 within the module

guide channel pairs **214** and sliding the module **216** along the module guide channel **214** toward the back of the module enclosure cavity **202**. As the module **216** approaches the back of the module enclosure cavity **202**, the module housing power connector **226** and the module housing signal connector **228** contact the power connector **166** and signal connector **168**, respectively and mate together such that the power and signal leads from the module housing power connector **226** is connected to the power connector **166** and such that the module housing signal connector **228** is connected to the signal connector **168**. This advantageously provides power and signal connection between the module **216** and the base enclosure **102**.

Accordingly, when the airflow fans **242** are activated, the air flow path is directed upward toward the vent openings **244**. As discussed above the chimney airflow module **217** may be used to further direct the airflow to the modules **216**. This advantageously creates and operates as a “heat chimney” directing the airflow over the module component and directing heat from the modules components up and out of the vent openings **244**.

In accordance with one embodiment of the present invention, a method for reducing heat within a module enclosure is provided and includes creating and/or receiving an airflow into the enclosure, directing the airflow through the enclosure such that the airflow is at least partially incident on at least one of the heat generating and/or non-heat generating components and directing the airflow out of the enclosure, where the airflow may be created/directed using active methods (i.e. fans) and/or passive methods (guides).

It should be appreciated that the enclosure proportions may be based on airflow and/or Ampacity requirements. This advantageously allows for the enclosures to be reduced in size. For example, FIG. **16** shows one embodiment of different sizes for an MPC **100** relative to Ampacity with varying number of modules. Additionally, the configuration of the present invention advantageously provides a degree of isolation between the internal components of the MPC **100** and the external environment, resulting in a safer system and reducing/eliminating the introduction of dust and other debris into the MPC **100**. Furthermore, the fan(s) **242** may be operated on a continuous basis (no on/off noise transitioning) to advantageously allow the MPC **100** to be used in noise sensitive environments. Moreover, the communication ability of the modules may allow the modules **216** to have the ability to report operational characteristics. For example, the module may be configured to report the temperature and amperage present at each channel. Or the module may be configured to check amperage, temperature or lamp hours of any other module from anywhere in the system. Also, modules may have zero-cross sensing to prevent arcing and extend the life of all the relays, whether they are single, double or dimming.

Additionally, it is contemplated that multiple MPCs's **100** may be connected together to create a larger control array. Furthermore, the design of the MPC **100** allows modules with single-pole devices and modules with double-pole devices to be used in the same system. Also, the design allows modules to be stacked in numerical order (if desired) and do not require balancing.

It should be appreciated that although the MPC **100** of the present invention is discussed herein as having six (6) modules, the MPC **100** of the present invention is preferably configured to accommodate any number of modules (in multiples of three (3)) suitable to the desired end result, such as 3, 6, 9, 12 or 15 modules. This is because the power phases (Phase A, Phase B, Phase C) are distributed across

three (3) of the power connectors **166**. For example, as discussed hereinabove, the first power connector **180** provides a connection to power Phase A and power Phase B, the second power connector **182** provides a connection to power Phase C and power Phase A and the third power connector **184** provides a connection to power Phase B and power Phase C. Accordingly, this configuration advantageously helps to ensure that the loads connected to the power phases are as balanced as possible across all three (3) phases (Phase A, Phase B, Phase C). It should be appreciated that in the above configuration the power phase-connector pattern (A-B, C-A, B-C) may be repeated every third power connector **166**. However, it should be appreciated that although the modules are discussed herein as being in groups of three (3, 6, 9, 12, 15, 18, etc. . . .) for load balancing purposes, any number of modules may be used as desired, such as 4, 5, 7, etc. . . . In this case, the system would operate, but would be unbalanced and thus less stable.

Referring to FIGS. **17-22**, a Modular Power Control System (MPCS) **300** is shown in accordance with another embodiment and includes a system enclosure **302** defining an enclosure cavity **304** and having an enclosure front **306** defining a front opening **308** communicated with the enclosure cavity **304**. The system enclosure **302** includes an enclosure rear **310**, enclosure sides **312**, enclosure bottom **314** and an enclosure top **316**. The system enclosure **302** further includes an enclosure door **318** which is attached to at least one of the enclosure front **304** and/or enclosure side **312**, where the enclosure door **318** is configurable (for example by rotating) to cover and/or uncover the front opening **308** to allow or prevent access to the enclosure cavity **304**. Additionally, the MPC **300** further includes at least one first module internal support **320**, at least one second module internal support **322**, at least one module **324** and a MPC controller **426**. It should be appreciated that the MPC **300** is configurable to include one or more modules **324** as desired. Additionally, for each module **324**, the MPC **300** includes one first module internal support slot **321** and one second module internal support slot **323**, wherein the first module internal support **320** and one side of the module **324** engage with each other and the second module internal support **322** and the other side of the module **324** engage with each other such that the module **324** is securely and removably contained within the enclosure cavity **304**.

Referring to FIG. **22A** and FIG. **22B**, the MPC **300** includes a first bus bar **326**, a second bus bar **328** and a third bus bar **330**, wherein the first bus bar **326**, second bus bar **328** and third bus bar **330** are connected to the enclosure rear **310** via an electrically insulated mount. It should be appreciated that the first bus bar **326** includes a Phase A power input terminal **332** connected to the first bus bar **326**, a Phase B power input terminal **334** connected to the second bus bar **328** and a Phase C power input terminal **336** connected to the third bus bar **330**. It should be further appreciated that the first bus bar **326**, second bus bar **328** and third bus bar **330** are configured to extend vertically between the enclosure top **316** and enclosure bottom **314** to be proximate to and extend away from the enclosure rear **310**. The MPC **300** further includes a neutral terminal **338** and a ground terminal **340** located proximate the enclosure rear **310** and the enclosure top **316** (and/or enclosure bottom **314** as desired) includes one or more openings of which input power are brought into and output power is brought out of the system enclosure **302**. Thus, the ground connection for the modules **324** is provided through the system chassis. Referring to FIG. **22B**, it should be appreciated that although the bus bars **326**, **328**, **330** are

shown as being generally rectangular plates of a conductive material, the bus bars **326**, **328**, **330** may be any shape desired. Additionally it should be appreciated that the bus bars **326**, **328**, **330** are securely connected to the enclosure rear **310** via a bus bar mounting device **327** wherein the bus bars **326**, **328**, **330** are connected to the bus bar mounting device **327** via an insulated mounting block **329**.

As discussed briefly above the MPCS includes at least one first module internal support slot **321** and at least one second module internal support slot **323**, wherein the first module internal support slot **321** and second module internal support slot **323** are located within the enclosure cavity **304**. It should be appreciated that the first module internal support **320** is securely connected to the internal surface of one enclosure side **312** and the second module internal support **322** is securely connected to the internal surface of the other enclosure side **312**, such that the first module internal support slot **321** and the second module internal support slot **323** form a slot pair and are located in approximately the same horizontal plane. It should be appreciated that in the embodiment disclosed herein, MPCS **300** includes four (4) modules **324** wherein each of the modules **324** is removably associated with the system enclosure **302** via a pair of first and second module internal support slots **321**, **323**. It is contemplated that in other embodiments, the MPCS **300** may be configured to have as many modules **324** as desired, such as one (1) module **324** or ten (10) modules **324**. Additionally, it is contemplated that multiple first module internal supports slots **321** and/or multiple second module internal support slots **323** may be combined in a single structure (See FIG. 22A) and/or may be single units that are connected to the internal side wall of the system enclosure **302**.

Referring to FIG. 23 to FIG. 33B, the module(s) **324** are similar to the modules as discussed hereinabove and includes a module front **344**, a module rear **346**, a module top **348**, a module bottom **350** and two module sides **352**, wherein the module rear **346**, module top **348**, module bottom **350** and module sides **352** define a module cavity **354** for containing multiple components. It should be appreciated that as discussed hereinabove, the module components are dependent upon the function of the module **324**. For example, if the module **324** is a dimmer module, then the module **324** may contain dimmer power components (such as two (2) or more SCR 120V 10 A dimmers) as well as dimmer control circuitry. In another embodiment, if the module **324** is a relay module, then the module **324** may contain single-pole (such as two (2) Single-Pole 20 A 120V relays) or double-pole (such as one (1) Double-Pole 20 A 220V relay) relays as well as relay control circuitry/switches. It is contemplated that the MPCS **300** may include any mix of modules **324** as desired. For example, although the MPCS **300** is described herein as using relay and dimmer modules, any type of modules that may be used for power distribution applications (i.e. for architectural, entertainment, etc.) may be used, such as modules that provide power and control of fluorescent ballasts and various other dimming techniques. Also, the modules may be used for power distribution and control to various other types of electronic/electrical equipment. It should be appreciated that the present invention advantageously provides access to all power phases as desired without having to reconfigure the entire system. Furthermore, the modules **324** include a module output terminal **325** electrically associated with one or more of the module components to allow the power that was conditioned by the module components to be distributed out of the MPCS **300**, wherein the module output terminal **325**

includes a Phase A conductor electrically connected to the conditioned Phase A signal, a Phase B conductor electrically connected to the conditioned Phase B signal and a Phase C conductor electrically connected to the conditioned Phase C signal.

Additionally, similar to the module shown in FIG. 7C, it should be appreciated that module **324** may also be configured as a chimney airflow module **324**, where the module cavity **354** is left unpopulated (or only sparsely populated) with an area that is substantially free of obstruction to allow airflow there through. The configuration of the chimney airflow module **324** advantageously acts as a flow path guide to direct airflow between the enclosure bottom **314** and the enclosure top **316**. Referring to FIGS. 23-33B, the module sides **352** include a side channel guide **356** that is configured (i.e. size and shape) to slidingly and supportingly interact with the first and second module internal supports **320**, **322**, where the side channel guide **356** on one module side **352** interacts with the first module internal support **320** and the side channel guide **356** on the other module side **356** interacts with the second module internal support **322**, such that the module **324** is securely and removably contained with the enclosure cavity **304**. This may be accomplished via a resilient member **358** (associated with the first and/or second module internal support **320**, **322** and/or the side channel guide **356**) that prevents the module **324** from being removed from the side channel guide **356**. When the resilient member **358** is compressed, the module **324** may be removed from the side channel guide **356**.

Referring again to FIGS. 23-33B, as discussed above it should be appreciated that various types of modules **324** may be used with the MPCS **300**, wherein the MPCS **300** may include only one type of module or various types of modules, as desired. In one embodiment, a module **324** may be a Triple Single Pole Relay Module which is rated for 120V, 20 A power per circuit. In another embodiment, a module **324** may be a Triple Dimmer Module which is rated for 120V, 20 A power per circuit. In this embodiment, the dimmer may include a toroidal filter assembly which modifies the rate of current rise ("rise time") within that circuit and may operate with a rise time of 350 microseconds ( $\mu$ s). In still yet another embodiment, a module **324** may be a Single Pole Relay/Double Pole Relay Module which is rated for 120V, 20 A power per circuit. In still yet another embodiment, a module **324** may be a Single Dimmer/Dual Single Pole Relay Module which is rated for 120V, 20 A power per circuit. In this embodiment, the dimmer may include a toroidal filter assembly which modifies the rate of current rise ("rise time") within that circuit and may operate with a rise time of 350 microseconds ( $\mu$ s). In still yet another embodiment, a module **324** may be a Single Dimmer/Double Pole Relay Module which includes one SCR Dimmer Circuit rated for 120V, 20 A and one Double Pole Relay Circuit each rated for 240V, 20 A. In still yet another embodiment, a module **324** may be a Plenum Module which may occupy unpopulated module chamber slots. It should be appreciated that the MPCS **300** may be rated for any voltage/ampereage needed per application and as suitable to the desired end purpose. For example, FIG. 33B, illustrates embodiments of MPCS **300** configured for four (4), eight (8) and sixteen (16) modules.

Referring to FIGS. 34-37, the module **324** further includes a Phase A bus bar connector **360**, a Phase B bus bar connector **362** and a Phase C bus bar connector **364** located proximate the module rear **346**, wherein the Phase A bus bar connector **360** is configured to conductively associate with the first bus bar **326**, the Phase B bus bar connector **362** is

configured to conductively associate with the second bus bar **328** and the Phase C bus bar connector **364** is configured to conductively associate with the third bus bar **330**. It should be appreciated that the Phase A bus bar connector **360**, Phase B bus bar connector **362** and Phase C bus bar connector **364** are configured to have a receiving slot **365** that is sized and shaped to receive and conductively interact with the bus bars **326**, **328**, **330** such that a conductive connection is made between the bus bar connectors **360**, **362**, **364** and the bus bars **326**, **328**, **330**.

It should be appreciated that the Phase A, B, C connectors **360**, **362**, **364** are securely associated with the module rear **346** to extend therefrom and are connected to a circuit breaker **366** (or other switch or component that is located within the module). Additionally, an electrically insulated material **368** (such as Mylar and/or FR4 (Epoxy Laminate)) is used to separate the module rear **346** from the electrically conductive bus bars **326**, **328**, **330**. The Phase A connector **360** is connected to the circuit breaker **366** via a first bus bar **370**, the Phase B connector **362** is connected to the circuit breaker **366** via a second bus bar **372** and the Phase C connector **364** is connected to the circuit breaker **366** via a third bus bar **374**, wherein the first, second and third bus bars **370**, **372**, **374** are isolated via an insulating material (such as Powder Coat or Lamination). It should be appreciated that the Phase A, Phase B and Phase C power is then distributed to the module **324** following the circuit breaker **366** to allow the power phases to be isolated from the rest of the module **324** as desired. It should be appreciated that in other embodiments, the MPCS may be configured such that the electrically conductive bus bars **326**, **328**, **330** may be located on the rear of the module **324** and the bus bar connectors **360**, **362**, **364** are located on the rear of the enclosure. Additionally, it should be appreciated that the electrically conductive bus bars **326**, **328**, **330** may also include a neutral bus bar and a ground bus bar and the bus bar connectors may include a neutral bus bar connector and a ground bus bar connection for connection to the module **324**. This would allow the neutral and ground to be connected directly to the modules **324** if desired. It is contemplated that any number and/or arrangement of bus bars and bus bar connectors may be used as desired.

Additionally, referring to FIG. **38** to FIG. **40**, the MPCS **300** further includes a terminal backplane **376** having one or more Terminal Blocks (TB) **378**, wherein each of the Terminal Blocks (TB) **378** include a Terminal-Module Interface (TMI) **380** and an output distribution block **382**. It should be appreciated that the output distribution block **382** includes a Phase A output wire connector **384**, a Phase B output wire connector **386** and a Phase C output wire connector **388** and the TMI **380** includes a TMI Phase A connector **390**, a TMI Phase B connector **392** and a TMI Phase C connector **394**, wherein the Phase A output wire connector **384** is electrically connected to the TMI Phase A connector **390**, the Phase B output wire connector **386** is electrically connected to the TMI Phase B connector **392** and the Phase C output wire connector **386** is electrically connected to the TMI Phase C connector **392**. Moreover, it should be appreciated that in one embodiment the TMI **380** is configured to receive and frictionally contain the module output terminal **325** of the module **324** via a "push-in" connection.

When the module **324** is associated with the MPCS **300**, the side channel guide **356** on one module side **352** interacts with the first module internal support **320** and the side channel guide **356** on the other module side **356** interacts with the second module internal support **322** to lockingly and securely locate the module with the MPCS **300**. When

the module **324** is fully inserted into the MPCS **300** the first bus bar **326** slides into and is contained within the Phase A bus bar connector **360** to conductively associate with the first bus bar **326**, the second bus bar **328** slides into and is contained within the Phase B bus bar connector **362** to conductively associate with the second bus bar **328** and the third bus bar **330** slides into and is contained within the Phase C bus bar connector **364** to conductively associate with the third bus bar **330**.

Referring again to FIG. **37** the bus bar **326**, **328**, **330** fits within the Phase A, B, C connectors **360**, **362**, **364** such that a conductive connection between the bus bar **326**, **328**, **330** and the Phase A, B, C connectors **360**, **362**, **364** exists. In this way, the Phase A, Phase B and Phase C power is connected to the modules **324**. It should be appreciated that this conductive connection may be accomplished via any method suitable to the desired end purpose, such as, but not limited to, a friction fit connection. Additionally, as the module **324** is lockingly and securely located within the MPCS **300**, the module output terminal **325** is pressingly and frictionally associated with the TMI **380** such that the Phase A conductor of the module output terminal **325** is electrically connected to the TMI Phase A connector **390**, the Phase B conductor of the module output terminal **325** is electrically connected to the TMI Phase B connector **392** and the Phase C conductor of the module output terminal **325** is electrically connected to the TMI Phase C connector **394**. As shown in FIG. **41** and FIG. **42**, it should be appreciated that the MPCS **300** may be configured for three-phase use or for single-phase use as desired.

Referring to FIGS. **43-46**, the MPCS controller **426** includes a controller front panel **428**, a controller backplane **429** and a system controller which may include a processing device and may be configured to accept multiple control communication protocols, distribute communications to modules **324** within the MPCS **300** and provide a user interface for panel commissioning and configuration. In accordance with one embodiment of the invention, the MPCS controller **426** may be configured to support a plurality of control protocols (such as, but not limited to DMX-512A, RDM, E1.31, sACN and ArtNET) and the front panel **428** may include a multi-button keypad **432** (that may be hard and/or soft (Touch Menu Items) keys) to control the MPCS **300** and input information and commands. The front panel **428** may further include a display **434** (for example, one embodiment may include a back-lit, two line, 20 character display visible on the front panel **428** that provides information for panel configuration and status indication) and may be configured to store multiple preset commands/parameters, wherein the preset commands/parameters may be user programmable and executable. Additionally, the MPCS controller **426** may be accessed and operated remotely and/or on-site and may be configured with a recorded preset that serves as an 'emergency' look (UL924) and that may be activated from the remote source. Furthermore, the MPCS controller **426** is communicated with the modules **324** to control the operation of the modules **324**. The MPCS controller **426** is configured to allow a user to set individual circuits to specific levels and allows the modules **324** to be active. Moreover, the front panel further includes a Ethernet connector **436** (for example, Neutrik®, ether-CON®) which allows for connection to Ethernet-based communication networks. Additionally, the controller backplane **429** is configured to distribute power (and/or control the distribution of power) throughout the system for operation of the MPCS **300**. In still yet other embodiments, the MPCS **300** may be operated via the MPCS controller **426** to

17

be fully automatic and/or each of the modules 324 may be configured to include a controller to assume partial or full control of the function of the modules 324 and may be configurable to operate in a parallel and/or a serial configuration.

Referring to FIG. 47 and again to FIG. 20, FIG. 21 and FIG. 39, the enclosure top 316 includes one or more upper vents 450 and the enclosure bottom 314 includes a lower vent 452, wherein the upper vent 450 is located to be directly over the modules 324 and the lower vent 452 is located to be directly under the modules 324. The MPCS 300 further includes one or more fans 454 which are located above the modules 324 to be between the modules 324 and the upper vent 450. It should be appreciated that in other embodiments the fans 454 and/or additional fans may be located below the modules 324 to be between the modules 324 and the lower vent 452. Referring to FIG. 48, it should be appreciated that this configuration allows for a combination of convention and forced-air airflow to flow into the lower vent 452, over and/or through the module components and cavities 354 and out of the upper vent 450. Additionally, the enclosure top 316 includes one or more top openings 456 (which may have removable covers) to allow input power to be brought in and output power to be brought out and the enclosure bottom 314 may include one or more bottom openings 458 (which may have removable covers) to allow control signals to be brought in.

It is contemplated that MPCS 100, 300 may include processing circuitry that is configurable to monitor the modules 324 and/or perform a self-check diagnostic procedure in a manner responsive to a predetermined algorithm on a system wide basis and/or on a module by module basis. Additionally, it is contemplated that the MPCS 100, 300 may also include a storage device that may store the results of the diagnostic procedure and/or performance history, wherein the storage device may be a volatile and/or a non-volatile memory suitable to the desired end purpose. Accordingly, the processing circuitry may include, but not be limited to, a processor(s), computer(s), memory, storage, register(s), timing, interrupt(s), communication interface(s), and input/output signal interface(s), as well as combination comprising any of the foregoing.

The invention may include (at least in part) a computer or controller implemented processes which may also be embodied in the form of computer program code containing instructions embodied in tangible media, such as floppy diskettes, CD-ROMs, hard drives, and/or any other computer-readable medium, wherein when the computer program code is loaded into and executed by a computer or controller, the computer or controller becomes an apparatus for practicing the invention. The invention can also be embodied in the form of computer program code, for example, whether stored in a storage medium, loaded into and/or executed by a computer or controller, or transmitted over some transmission medium, such as over electrical wiring or cabling, through fiber optics, or via electromagnetic radiation, wherein when the computer program code is loaded into and executed by a computer or a controller, the computer or controller becomes an apparatus for practicing the invention. When implemented on a general-purpose microprocessor the computer program code segments may configure the microprocessor to create specific logic circuits.

It should be appreciated that while the invention has been described with reference to an exemplary embodiment, it will be understood by those skilled in the art that various changes, omissions and/or additions may be made and equivalents may be substituted for elements thereof without

18

departing from the spirit and scope of the invention. In addition, many modifications may be made to adapt a particular situation or material to the teachings of the invention without departing from the scope thereof. Therefore, it is intended that the invention not be limited to the particular embodiment disclosed as the best mode contemplated for carrying out this invention, but that the invention will include all embodiments falling within the scope of the appended claims. Moreover, unless specifically stated any use of the terms first, second, etc. do not denote any order or importance, but rather the terms first, second, etc. are used to distinguish one element from another.

What is claimed is:

1. A modular power control system, comprising:
  - a an enclosure having an enclosure top, an enclosure bottom, an enclosure front, an enclosure rear, a first enclosure side and a second enclosure side, wherein the enclosure defines an enclosure cavity and wherein the enclosure further includes an input power connector;
  - a a module internal support, wherein the module internal support includes a first module support connected to the first enclosure side and a second module support connected to the second enclosure side, wherein the first module support includes a first module channel and the second module support includes a second module channel;
  - at least one module, wherein the at least one module includes a module top, a module bottom, a module rear, a module front and module sides which define a module cavity, wherein each of the module sides include a side channel guide for interacting with the first and second module channels to support the module, wherein the module includes at least one module power connector configured to conductively associate with the input power connector when the at least one module is located within the enclosure cavity and wherein the module top and module bottom are at least partially open to allow airflow through the module cavity.
2. The modular power control system of claim 1, wherein the at least one module power connector includes a module Phase A connector, a module Phase B connector and a module Phase C connector.
3. The modular power control system of claim 2, wherein each of the module Phase A connector, module Phase B connector and module Phase C connector defines a connector slot for interacting with the input power connector.
4. The modular power control system of claim 2, wherein the input power connector includes a Phase A bus bar, a Phase B bus bar and a Phase C bus bar, wherein the Phase A bus bar, Phase B bus bar and Phase C bus bar are proximate to and extend away from the enclosure rear.
5. The modular power control system of claim 4, wherein the module Phase A connector, module Phase B connector and module Phase C connector each define a connector slot and wherein when the at least one module is located within the enclosure cavity, the Phase A bus bar is located within the connector slot of the module Phase A connector, the Phase B bus bar is located within the connector slot of the module Phase B connector and the Phase C bus bar is located within the connector slot of the module Phase C connector.
6. The modular power control system of claim 1, wherein the enclosure top includes at least one opening configured to receive input power for distribution to the input power connector.
7. The modular power control system of claim 1, wherein the at least one module includes a plurality of modules

located within the enclosure cavity such that one of the plurality of modules is located either directly below or directly above another of the plurality of modules.

8. The modular power control system of claim 7, wherein the enclosure top includes a top vent opening and the enclosure bottom includes a bottom vent opening, wherein the plurality of modules are located within the enclosure cavity to be below the top vent opening and above the bottom vent opening.

9. The modular power control system of claim 8, further including at least one fan located within the enclosure cavity to be above the plurality of modules and below the top vent opening, such that when operated an airflow is created from the bottom vent opening through the plurality of modules to the top vent opening.

10. The modular power control system of claim 1, further comprising at least one of a neutral connection and a ground connection located proximate to the enclosure rear.

11. A modular power control system, comprising:  
an enclosure having an enclosure rear and defining an enclosure cavity,

an input power Phase A bus bar,  
an input power Phase B bus bar,  
an input power Phase C bus bar;

a first module support and a second module support located within the enclosure cavity and connected to the enclosure, wherein the first module support includes a first module channel and the second module support includes a second module channel; and

at least one module, wherein the at least one module includes a module top, a module bottom, a module rear, a module front and module sides, wherein each of the module sides include a side channel guide configured to slidably interacting with the first and second module channels to support the module within the enclosure cavity and wherein the module rear includes a module power Phase A connector configured to conductively mate with the input power Phase A bus bar, a module power Phase B connector configured to conductively mate with the input power Phase B bus bar and a module power Phase C connector configured to conductively mate with the input power Phase C bus bar when the module is contained within the enclosure cavity and wherein the module top and module bottom are at least partially open to allow air to flow through the module.

12. The modular power control system of claim 11, wherein the module power Phase A connector defines a connector slot configured to interact with the input power Phase A bus bar, the module power Phase B connector defines a connector slot configured to interact with the input power Phase B bus bar and the module power Phase C connector defines a connector slot configured to interact with the input power Phase C bus bar.

13. The modular power control system of claim 12, wherein when the at least one module is located within the enclosure cavity, the Phase A bus bar is located within the connector slot of the module Phase A connector, the Phase B bus bar is located within the connector slot of the module Phase B connector and the Phase C bus bar is located within the connector slot of the module Phase C connector.

14. The modular power control system of claim 11, wherein the input power Phase A bus bar, input power Phase B bus bar and input power Phase C bus bar are located proximate to and extend away from the enclosure rear.

15. The modular power control system of claim 11, wherein the enclosure includes an enclosure top and an enclosure bottom, wherein the enclosure top includes at least one opening configured to receive input power for distribution to at least one of the input power Phase A bus bar, input power Phase B bus bar and input power Phase C bus bar.

16. The modular power control system of claim 11, wherein the at least one module includes a plurality of modules located within the enclosure cavity such that one of the plurality of modules is located either directly below or directly above another of the plurality of modules.

17. The modular power control system of claim 11, wherein the enclosure includes an enclosure top and an enclosure bottom, wherein the enclosure top includes a top vent opening and the enclosure bottom includes a bottom vent opening, wherein the at least one module is located within the enclosure cavity to be below the top vent opening and above the bottom vent opening.

18. The modular power control system of claim 15, further comprising at least one fan located within the enclosure cavity to be above the at least one module and below the top vent opening, such that when operated an airflow is created from the bottom vent opening through the at least one module to the top vent opening.

19. The modular power control system of claim 11, further comprising at least one of a neutral connection and a ground connection located proximate to the enclosure rear.

\* \* \* \* \*