



US008496354B2

(12) **United States Patent**
Jurik et al.

(10) **Patent No.:** **US 8,496,354 B2**
(45) **Date of Patent:** **Jul. 30, 2013**

(54) **BEAM CONTROL SYSTEM FOR AN LED LUMINAIRE**

(75) Inventors: **Pavel Jurik**, Postredni Becva (CZ);
Josef Valchar, Postredni Becva (CZ)

(73) Assignee: **ROBE Lighting s.r.o.**, Postredni Becva (CZ)

(*) Notice: Subject to any disclaimer, the term of this patent is extended or adjusted under 35 U.S.C. 154(b) by 49 days.

(21) Appl. No.: **13/018,203**

(22) Filed: **Jan. 31, 2011**

(65) **Prior Publication Data**

US 2012/0127710 A1 May 24, 2012

Related U.S. Application Data

(60) Provisional application No. 61/417,194, filed on Nov. 24, 2010.

(51) **Int. Cl.**
F21V 33/00 (2006.01)

(52) **U.S. Cl.**
USPC **362/279**; 362/290; 362/342; 362/325;
362/311.02

(58) **Field of Classification Search**
USPC 362/279, 290, 342, 343, 311.02,
362/325
See application file for complete search history.

(56) **References Cited**

U.S. PATENT DOCUMENTS

7,517,113 B2 * 4/2009 Bruckner 362/290
7,587,109 B1 * 9/2009 Reiningger 385/116
2009/0009861 A1 * 1/2009 Hyobu 359/456

* cited by examiner

Primary Examiner — Laura Tso

(57) **ABSTRACT**

Described are an improved automated multi source luminaire and luminaire systems. More particularly an multicolor LED array luminaire system with a series of lenses and light louvers to control the light beam.

1 Claim, 12 Drawing Sheets

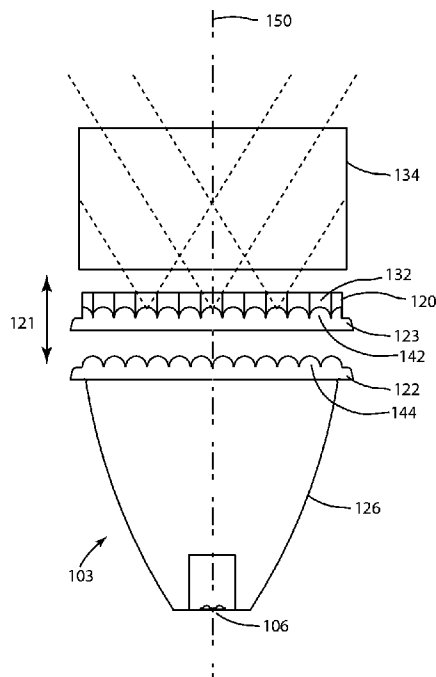
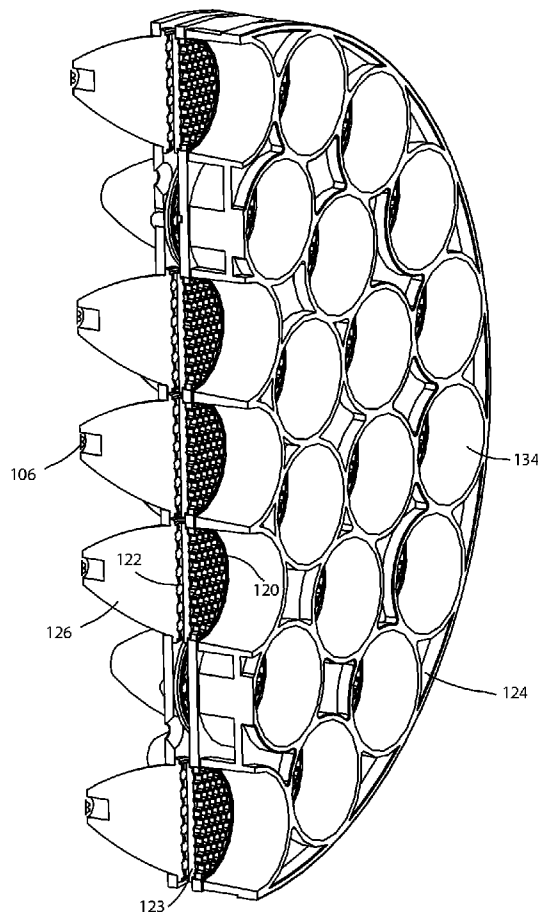

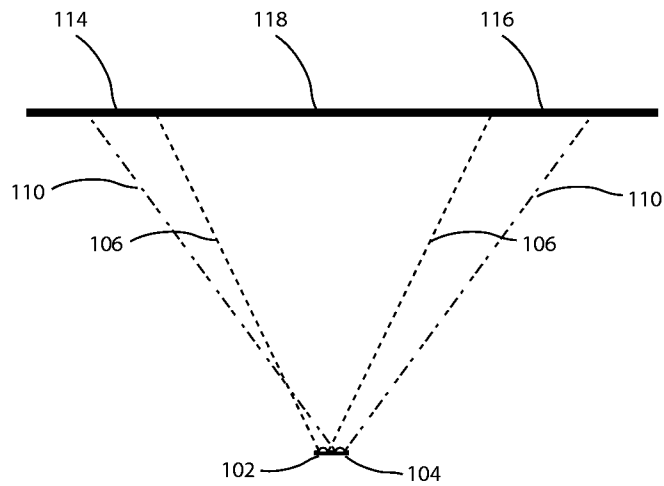

(Prior art)

FIG 1

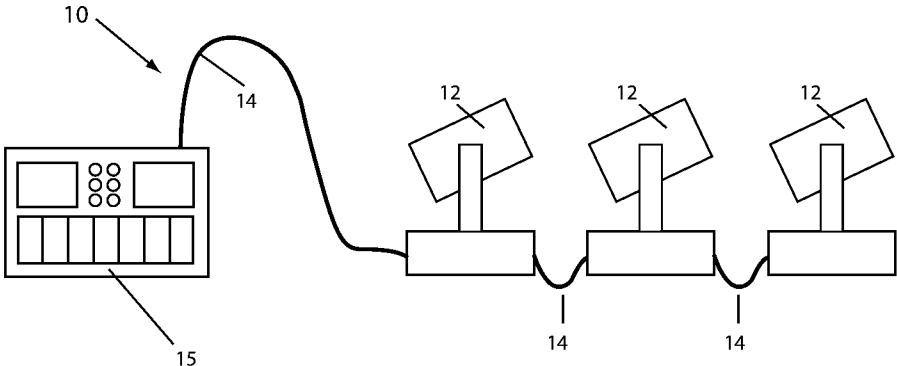

FIG 2

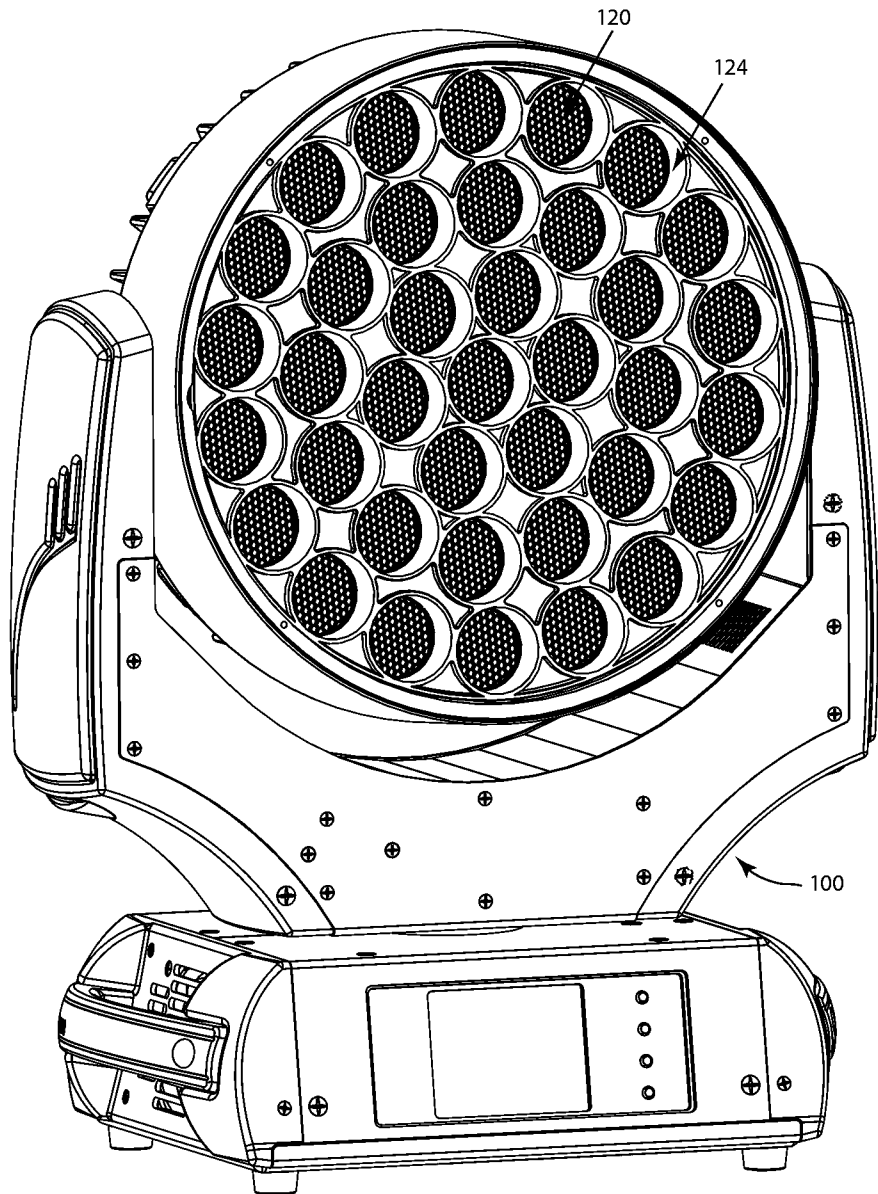

FIG 3

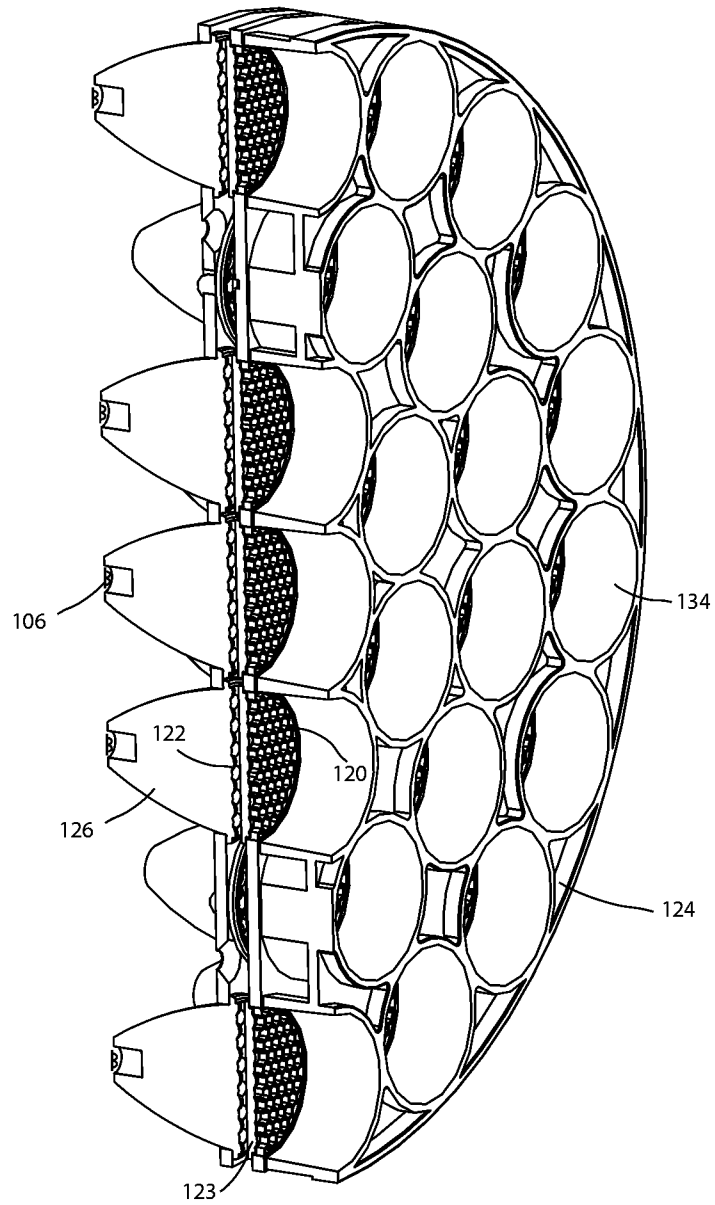

FIG 4

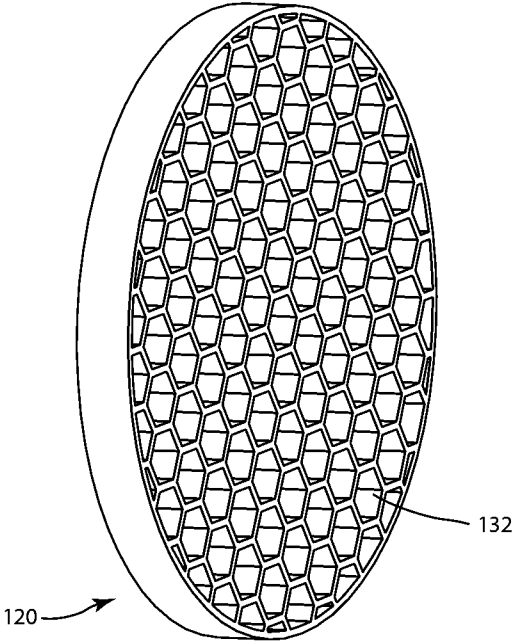

FIG 5

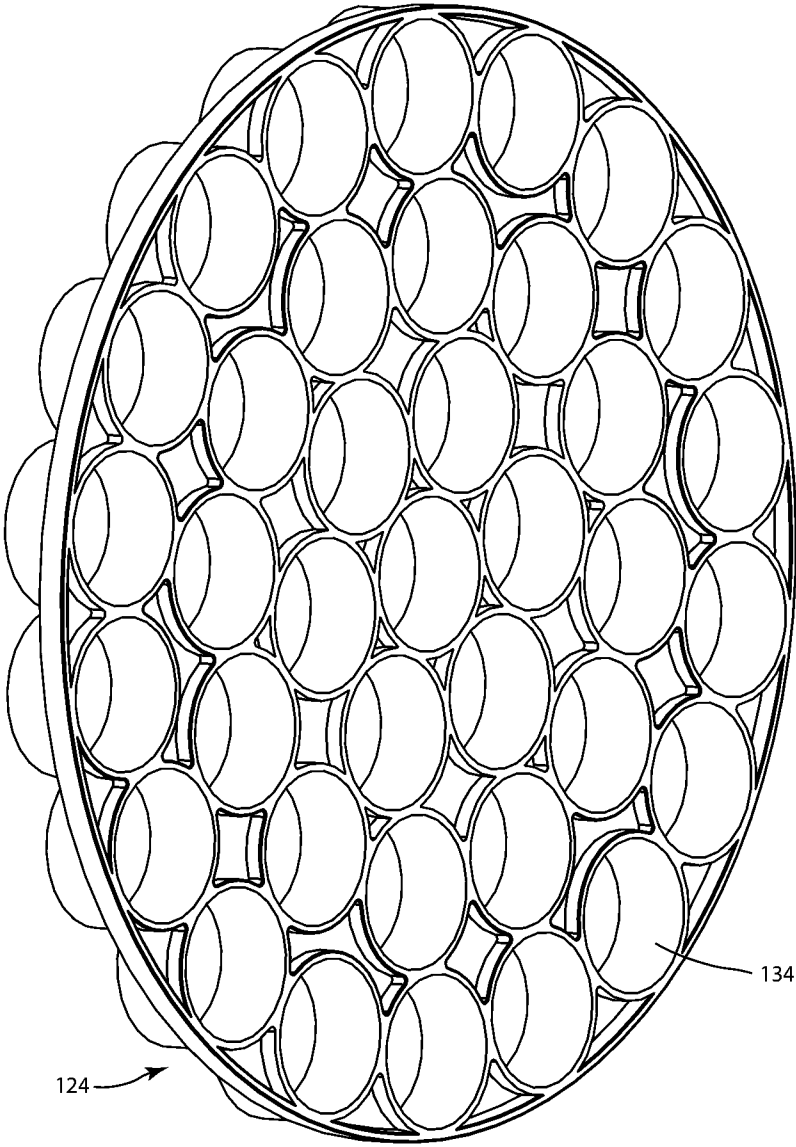

FIG 6

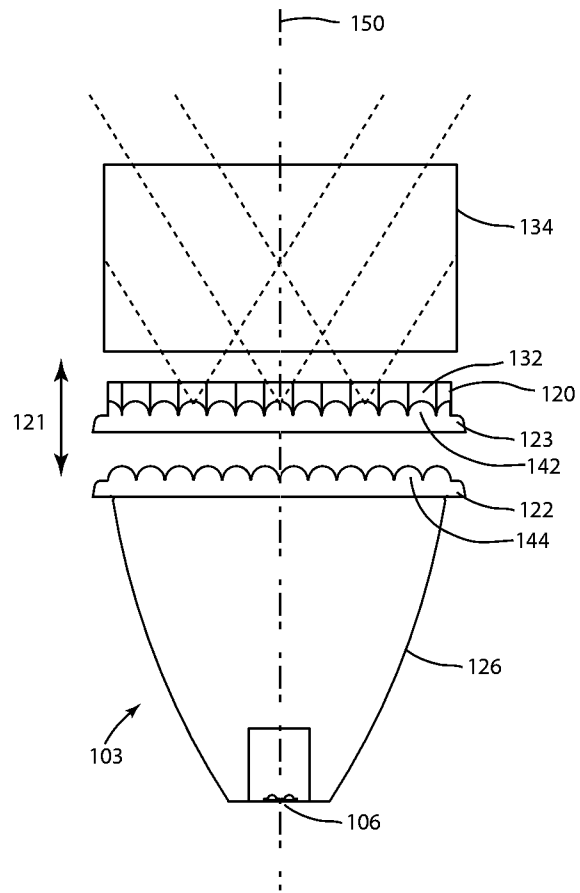

FIG 7

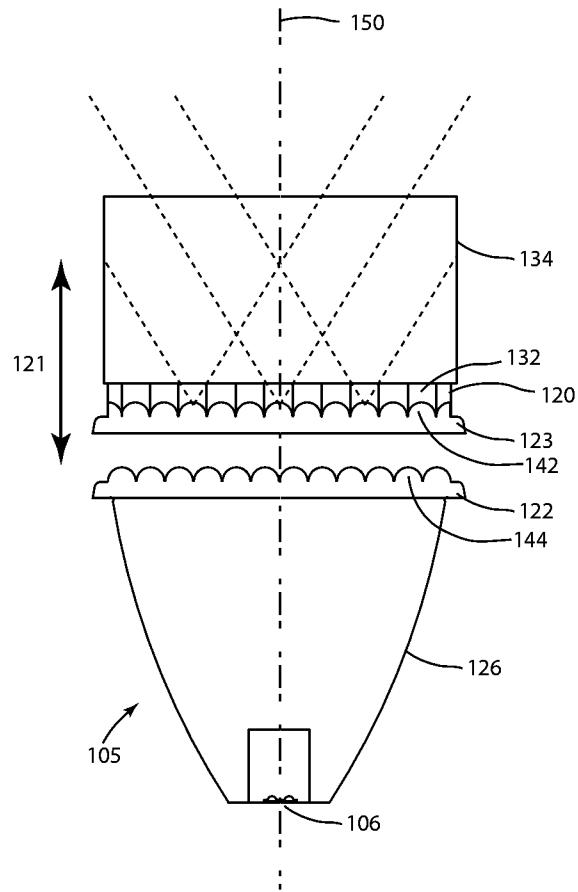

FIG 8

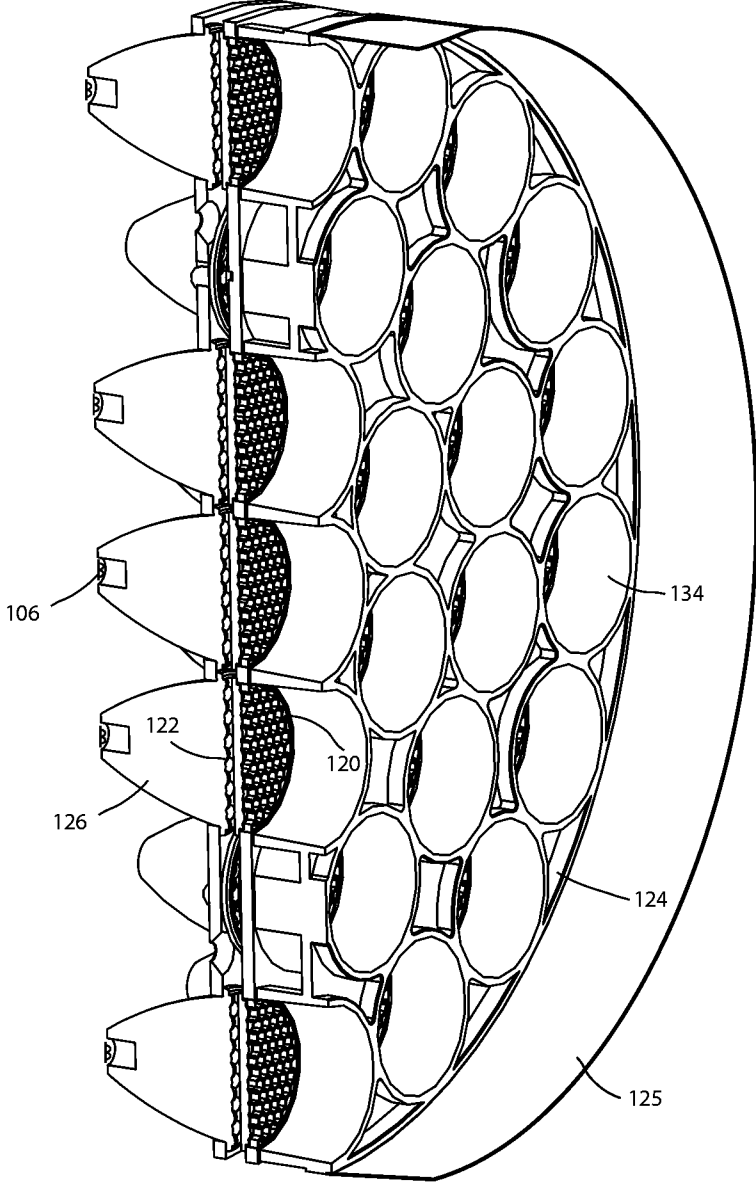

FIG 9

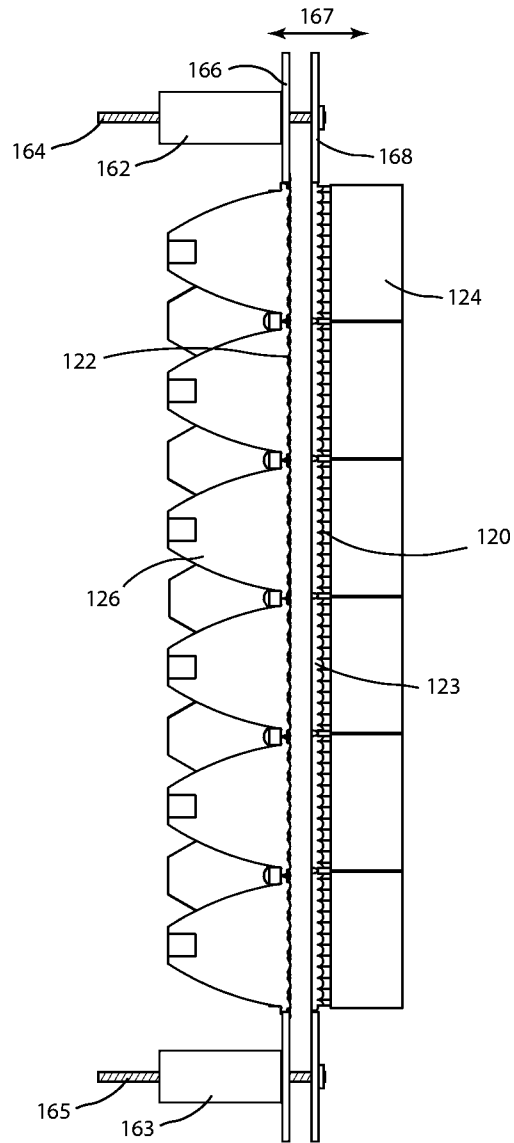

FIG 10

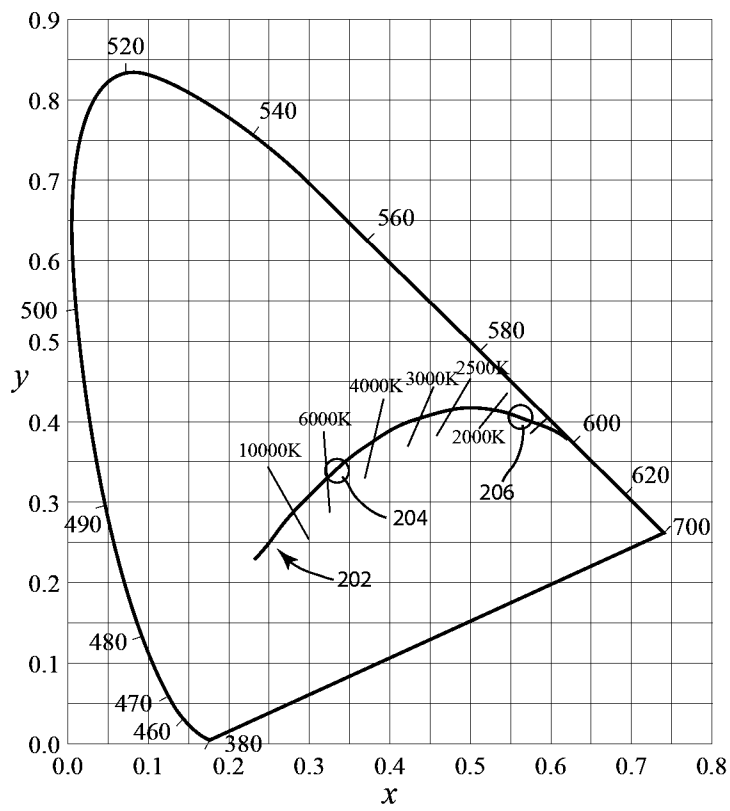

FIG 11

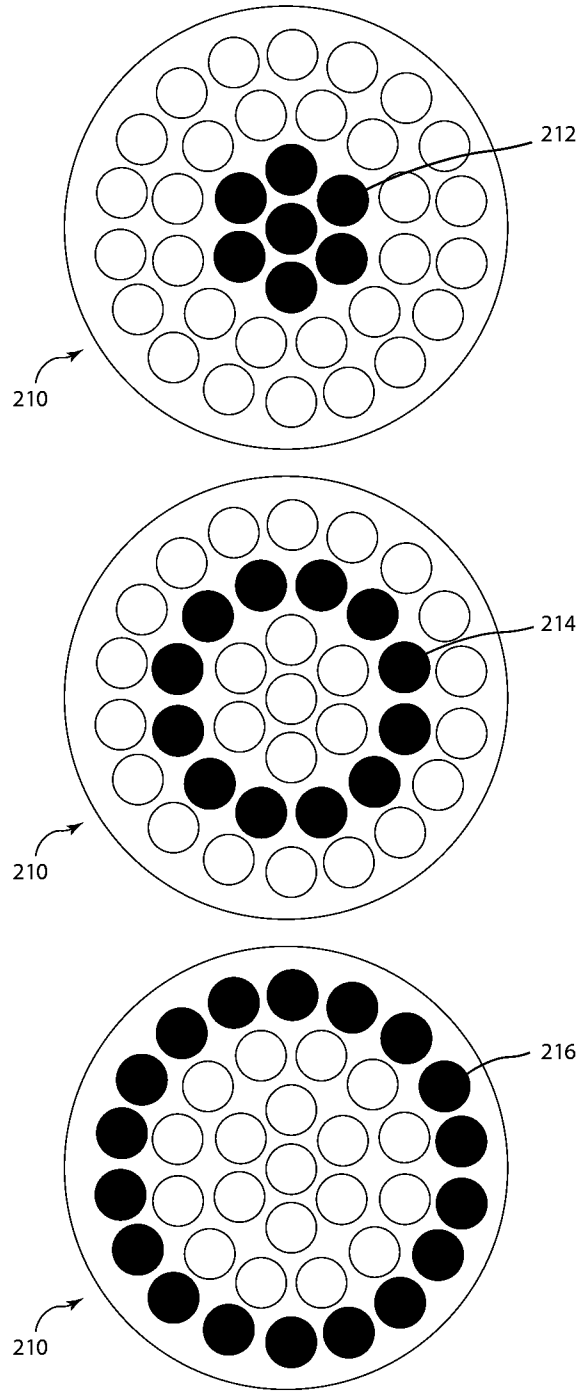

FIG 12

1

**BEAM CONTROL SYSTEM FOR AN LED
LUMINAIRE**

RELATED APPLICATION

The present application claims priority on Provisional Application No. 61/417,194 filed on 24 Nov. 2010.

TECHNICAL FIELD OF THE INVENTION

The present invention generally relates to a method for controlling the light output from an array of LEDs when used in a light beam producing luminaire, specifically to a method relating to preventing spill light and/or for controlling the beam angle of the array.

BACKGROUND OF THE INVENTION

High power LEDs are commonly used in luminaires—for example in the architectural lighting industry in stores, offices and businesses as well as in the entertainment industry in theatres, television studios, concerts, theme parks, night clubs and other venues. These LEDs are also being utilized in automated lighting luminaires with automated and remotely controllable functionality. For color control it is common to use an array of LEDs of different colors. For example a common configuration is to use a mix of Red, Green and Blue LEDs. This configuration allows the user to create the color they desire by additively mixing appropriate levels of the three colors. For example illuminating the Red and Green LEDs while leaving the Blue extinguished will result in an output that appears Yellow. Similarly Red and Blue will result in Magenta, and Blue and Green will result in Cyan. By judicious control of these three controls the user may achieve any color they desire within a color gamut. More than three colors may also be used and it is well known to add an Amber or White LED to the Red, Green and Blue to enhance the color mixing and improve the gamut of colors available.

The differently colored LEDs may be arranged in an array in the luminaire where there is physical separation between each LED, and this separation, coupled with differences in die size and placement for each color, may affect the spread of the individual colors and results in objectionable spill light and/or color fringing of the combined mixed color output beam. It is common to use a zoom lens or other optical device in front of each LED to allow the user to control the beam shape and angle of the output beam; however these optical devices commonly have differing effect for different colors and color fringing or other aberrations may be visible in the output beam. It would be advantageous to have a system where the beam angle is remotely variable and where stray light and aberrations are well controlled.

There is a need for a beam control system for an LED array based luminaire which can be remotely variable and provide improvements in spill light reduction and beam angle control.

BRIEF DESCRIPTION OF THE DRAWINGS

For a more complete understanding of the present invention and the advantages thereof, reference is now made to the following description taken in conjunction with the accompanying drawings in which like reference numerals indicate like features and wherein:

FIG. 1 illustrates a prior art system;

FIG. 2 illustrates a typical automated lighting system;

FIG. 3 illustrates an embodiment of the invention;

2

FIG. 4 illustrates a cut-away view of components of the embodiment of the invention illustrated in FIG. 3;

FIG. 5 illustrates a small louver mask of an embodiment of the invention;

FIG. 6 illustrates a large louver mask of an embodiment of the invention;

FIG. 7 illustrates a single module of the embodiment of the invention illustrated in FIG. 3;

FIG. 8 illustrates a single module of an alternative embodiment of the invention;

FIG. 9 illustrates a cut-away view of an embodiment of the invention;

FIG. 10 illustrates a side cross-sectional view of an embodiment of the invention;

FIG. 11 illustrates the CIE 1931 chromaticity space with Planckian locus; and

FIG. 12 illustrates strobe and control zones of an embodiment of the invention.

DETAILED DESCRIPTION OF THE INVENTION

Preferred embodiments of the present invention are illustrated in the FIGURES, like numerals being used to refer to like and corresponding parts of the various drawings.

The present invention generally relates to a method for controlling the light output from an array of LEDs when used in a light beam producing luminaire, specifically to a method relating to preventing spill light and for controlling the beam angle of the array.

FIG. 1 illustrates a prior art system showing two LEDs as may be used in a luminaire. LED 102 and LED 104 may be of differing colors and, due to the different optical properties and construction of the LED dies, respectively produce light beams 106 and 110. These beams may differ in beam spread and position. These differences result in light beams from LEDs 102 and 104 impinging on an illuminated object 118 in such a way that areas 114 and 116 of the object are illuminated by a single LED only rather than the desired mix of both. This results in areas 114 and 116 being colored differently from the central mixed area and appearing as colored fringes. Only Two (2) LEDs are illustrated in FIG. 1 for clarity and simplicity. It should be appreciated that the same problem exists with systems incorporating more than two colors of LED. In addition to multiple colors of LEDs the luminaire may incorporate multiple sets of luminaires and the spacing between the LEDs and sets of LED's may vary within a single luminaire or in different luminaire designs.

FIG. 2 illustrates a typical multiparameter automated LED luminaire system 10 which may incorporate the invention. These systems commonly include a plurality of multiparameter automated luminaires 12 which typically each contain on-board an array of LEDs, and electric motors coupled to mechanical drives systems and control electronics (not shown). In addition to being connected to mains power either directly or through a power distribution system (not shown), each luminaire is connected in series or in parallel to data link 14 to one or more control desk(s) 15. The luminaire system 10 is typically controlled by an operator through the control desk 15. Consequently, to affect this control, both the control desk 10 and the individual luminaires typically include electronic circuitry as part of the electromechanical control system for controlling the automated lighting parameters.

FIG. 3 illustrates an automated luminaire embodiment of the invention. Luminaire 100 contains multiple LED modules each of which is fitted with primary optics, first and second micro lens arrays and relatively small 120 and large 124 louver masks. Different louver masks 120 and 124 may have

different heights and width louvers array. By changing the louver masks to ones with different heights of louver array the user may control the beam angle, stray light and color fringing of the luminaire in addition to that control provided by the variable focal length micro lens arrays system described in greater detail below. Louver mask arrays **120** and **124** may further provide mechanical protection and dust exclusion for the micro lens arrays and LED modules.

FIG. 4 illustrates a cut-away view of assembled light path components of an embodiment of the dual louvered LED arrays from the automated luminaire **100** of FIG. 1. From left to right individual LED module(s) **106** is/are paired with primary optic(s) **126**, which in turn is/are paired with a first micro lens array **122**, which in turn is paired with a second micro lens array **123**, which in turn is paired with small louver array mask **120**, which in turn is paired with large louver mask **134**. In the embodiment illustrated in FIG. 4, the LED modules **106** are configured in an array and the large louver masks **134** also forms an array **124** where each LED Module **106** is paired a large louver mask **134** in the large louver mask array **124**.

In various embodiments Each LED module **106** may comprise a single LED die of a single color or a group of LED dies of the same or differing colors. For example in one embodiment LED **106** comprises one each of a Red, Green, Blue and White die. In some embodiments these LED die(s) may be paired with optical lens element(s) as part of the LED module. Though the LED modules **106** shown are illustrated as individual pieces, in various embodiments these modules **106** may set out in an array of multiple modules as a one piece or multiple pieces. Similarly the primary optics **126** are illustrated as one piece per LED module. In other embodiments the primary optics may be configured in an array of multiple primary optics to be paired with an array of multiple LED modules. Likewise the first micro lens arrays **122** are illustrated as individual pieces. In other embodiments the first micro lens arrays **122** may be part of a larger array to be paired with an array of multiple LED modules.

FIG. 5 illustrates a small louver mask array of an embodiment of the invention. Louver mask **120** contains multiple cells **132** each of which may be aligned with a single lens **142** of second micro lens array **123** as illustrated in FIG. 7 and FIG. 8. The illustrated louver mask utilizes hexagonal cells **132** however in other embodiments the cells may make up any shape such as round, triangular, square, or other shape(s). In the embodiment shown, the small louver mask array is shown as a piece for a single LED module **106** (not shown in this figure). In other embodiments where there is an array of LED modules **106**, the small louver mask arrays may in turn be configured as an array of small louver masks to be paired with an array of LED modules **106**. In other embodiments the small louver mask may be a single part that covers multiple LED modules **106**.

In one embodiment of the invention every louver mask **120** on each module in the luminaire is identical and every cell **132** within those masks is also identical but in further embodiments the louver masks **120** or cells **132** may differ within a single module or between different modules across the luminaire. In yet further embodiments the height of louver mask array **120** may be varied to effect different controlled beam angles for the emitted light. Such combinations of differing optical elements and louver array height may be advantageously chosen so as to allow fine control of the beam shape and quality. The louver mask arrays reduce color fringing or halation and control the beam angle to provide the lighting designer with a well controlled and defined beam of a single homogeneous color.

FIG. 6 illustrates the large louver masks array **124** of the embodiment of the invention illustrated in FIG. 3 and FIG. 4. Louver mask array **124** contains multiple cells **134** each of which may be aligned with an LED module **106** (not shown in FIG. 6) and its associated primary optic **126** (not shown in FIG. 6), first **122** (not shown in FIG. 6) and second micro lens array **123** (not shown in FIG. 6) and first, small, louver mask **120** (not shown in FIG. 6). The illustrated louver mask utilizes round cells **134** however in other embodiment other cell shapes may be employed.

In one embodiment of the invention every louver mask cell **134** is identical but in further embodiments the louver mask cells **134** may differ at different positions across the array. In yet further embodiments the height of cells **134** of louver mask array **124** may be varied to effect different controlled beam angles for the emitted light. Such combinations of differing optical elements and louver array height may be advantageously chosen so as to allow fine control of the beam shape and quality.

FIGS. 7 and 8 illustrate operation of the various optical elements of the luminaire as they relate to a single LED module **106** of an embodiment of the invention in two different embodiments **103** and **105**. The light output from an LED module **106** which may contain multiple LEDs of the same or differing colors enters primary optic **126**. Primary optic **126** provides beam collimation and may be a reflector or a lens utilizing total internal refraction (TIR). After passing through and being constrained by primary optic **126** the light beam enters first and second micro lens arrays **122** and **123** comprised of micro lenses **144** and **142** respectively. In the embodiment illustrated the first micro lens array **122** is fixed in position relative to LED module **106** and primary optic **126** while second micro lens array **123** is able to move **121** along or parallel to the optical axis **150** of the system. The two micro lens arrays **122** and **123** together form an optical system whose focal length may be varied by moving second micro lens array **123** towards and away from first micro lens array **122** as indicated by arrow **121**. The micro lenses in micro lens arrays **122** and **123** may both face in the same direction as illustrated here or may face in opposing directions. The use of micro lens arrays as opposed to single larger lenses has a number of advantages, including but not limited to:

- a. Micro lens arrays may be significantly thinner than a single lens of the same focal length and thus lighter and easier to move.
- b. Micro lens arrays may provide homogenization of the light beam as well as altering the beam divergence.

In the present disclosed embodiment second micro lens array **123** is associated with a first, small, louver mask **120** which may be attached to second micro lens **123** and will move along the optical axis with it. Small louver mask **120** may be in contact with second micro lens array **123** in order to maximize the effectiveness and prevent any stray light from passing underneath small louver mask **120**. As the combination of second micro lens array **123** and associated small louver mask **120** traverses backwards and forwards along or parallel to the optical axis **150** of the optical system as indicated by arrow **121** the focal length of the optical system formed by micro lens arrays **122** and **123** and primary optic **126** will vary, and thus the divergence of the light beam exiting second micro lens array **123** will vary as it passes through small beam louver **120**. This resultant output beam is then further constrained by second, large, beam louver **124**.

Large beam louver **124** may be in a fixed position relative to LED module **106**, primary optic **126** and first micro lens array **122** as shown with embodiment **103** as illustrated in FIG. 7 or may be allowed to traverse along the optical axis of

5

the optical system in conjunction with small louver mask **120** and micro lens array **123** as shown with embodiment **105** as illustrated in FIG. **8** and indicated by arrow **121**. In either configuration large beam louver **124** provides a further masking of any stray light from the variable focal length system and further serves to eliminate colored fringing from the light beam. An advantage of the embodiment illustrated in FIG. **7** is that the output louver **124** does not move. The advantage of the embodiment illustrated in FIG. **8** is that the controlling effects of the louver are consistent throughout the range of beam angle control when it remains adjacent to the first louver mask array **120**. FIG. **9** illustrates that a final, third, overall louver mask **125** may optionally be fitted to the luminaire. Such a louver mask is commonly known in the art as a 'top hat' and, in the described embodiments, will cooperate with the louver masks **120** and **124** to further control any remaining light spill from the luminaire. Optional louver mask **125** may advantageously be provided as a removable component such that the user may easily insert or remove it from the luminaire as desired. Optional louver mask **125** may be of fixed height or may be adjustable. Optional louver mask **125** may advantageously be non-reflective so as to avoid spill light, this may be achieved by painting or coating the louver mask with matte black paint, anodizing or other coating as known in the art.

It can be seen that changing the heights of one or both louver masks **120** and **124** will alter the constrained beam angle of the output beam. A taller louver will produce a narrower beam and a shorter louver will produce a wider beam. The louver masks **120** and **124** may be of fixed height or may be adjustable. As previously described Louver masks **120** and **124** may be non-reflective so as to avoid spill light, this may be achieved by painting or coating the louver mask with matte black paint, anodizing or other coating as known in the art. LED module **106** may contain LEDs of a single color and type or of multiple colors. The invention is not limited by the number, colors, or types of LEDs used and is applicable with any layout of any number of any type and any color of LEDs or OLEDs.

FIG. **10**, an illustration of a side cross-sectional view of the embodiment detailed in FIG. **8**. Louver masks **120** and **124** and second micro lens array **123** are mounted to carrier **168** to be carried back and forth in direction(s) **167** increasing or decreasing their distance from first micro lens array **122** as further described below. Stepper motor linear actuators **162** and **163** are mounted to plate **166** which is fixed relative to first micro lens array **122** and primary optic **126**. The output rods **164** and **165** of linear actuators **162** and **163** are connected to carrier **168**. As stepper motor linear actuators **162** and **163** are operated their respective output rods **164** and **165** will be extended or retracted, causing carrier plate **168** and attached louver masks **120** and **124** and second micro lens array **123** to move away from or closer to first micro lens array **122** and primary optic **126**. Although two stepper motor linear actuators are herein illustrated the invention is not so limited and any number of stepper motor linear actuators may be utilized. Stepper motor linear actuators **162** and **163** may be operated cooperatively and simultaneously such that carrier **168** and its attached optical assembly remains parallel to plate **166** and its attached optical assembly.

FIG. **11** and FIG. **12** illustrate a further improvements of the previously described embodiments of an LED based luminaire related to adjusting the white light produced by suitable combinations of intensities of colored light from LED modules **106**. For example red, green and blue LEDs may be mixed to form a white light by choosing appropriate levels for each of the three colors. The color temperature of the white

6

light produced may be selected from a range as illustrated by line **202** on the standard CIE 1931 chromaticity space as illustrated in FIG. **11**. The range of white light points of different color temperatures are shown on such a diagram by the curved line **202** is well known as the Planckian Locus or Black Body Line. Specific points on the Planckian locus are defined by the color temperature at that point, where the color temperature is the temperature in Kelvin (K) that a theoretically perfect black body would have to be to emit the same radiation spectrum. For example, an incandescent lamp may have a color temperature of 3,200K which indicates that the white light radiation from it is the same as that emitted from a perfect black body heated to 3,200K. Color temperatures of white light may range from the very high, blue, end of the Planckian locus at 10,000K or more down to the very low, red, end at 1,000K or less. As an incandescent lamp is dimmed from full output to blackout its color temperature will drop and its color point will tend to move along the Planckian locus. This is familiar as the well-known phenomenon of an incandescent lamp getting redder as it dims. For example a lamp whose color temperature is 5,600K (as shown by point **204** in FIG. **11**) may be dimmed in output and its color temperature may drop to around 1,500K (as shown by point **206** in FIG. **11**). Although LED emitters do not naturally exhibit this phenomenon as they are dimmed, the described embodiment simulates such a color temperature shift by continuously varying the intensity mix of colored light from LED modules **106** so as to produce white light of the appropriate color temperature. Such a simulation in the change of color temperature as the luminaire is dimmed allows the LED luminaire to emulate the appearance of an incandescent luminaire. The desired combinations of the colored LED emitters necessary to produce white light of any required color temperature along the Planckian locus may be stored in a look-up table within the luminaire or calculated as needed from calibration parameters. To further improve the simulation of an incandescent light source by the disclosed LED luminaire further embodiments of the invention may also include a delay in the intensity control so as to simulate the thermal lag of an incandescent filament. When the power being supplied to an incandescent bulb is altered, the resultant light level emitted from the lamp doesn't immediately change to follow the power change. Instead there is a slight delay as the filament in the lamp either heats up or cools down until it reaches its new equilibrium. This delay, or thermal lag, is familiar to users of incandescent products and appears natural, thus the very rapid control of LED based luminaires, which follow power changes with almost no lag, can appear unnatural and mechanical. In the described invention means are provided, either through software or through electrical circuitry, to simulate this thermal lag by regulating the power supplied to the LED emitters so as to mimic the heat up and cool down delay of an incandescent filament.

FIG. **12** illustrates the strobe and control zones of an embodiment of the invention. In one embodiment of the invention the LED modules **106** are arranged in rings or control zones. FIG. **12** shows luminaire **210** with control zones **212**, **214** and **216**. Although three control zones are herein illustrated the invention is not so limited and any number and shape of control zones may be utilized. It is common in automated LED luminaires to provide a single strobe control channel for the entire luminaire such that varying speeds and styles of strobing may be selected for the luminaire. In one embodiment of the invention the luminaire is instead provided with a number of strobe control channels, one for each zone. Each of the control zones **212**, **214** and **216** may be controlled individually and independently of the other

control zones. In particular a different strobe speed and style may be applied to each of the control zones. These styles and speeds may further be coordinated such that a pleasing overall effect is obtained automatically. Strobe styles may be selected from a list comprising but not limited to; simple strobe, snap-ramp strobe, ramp-snap strobe, ramp-ramp strobe, random strobe, flicker strobe and other strobe styles known in the art. In yet further embodiments the overall synchronization of control zones may be coordinated through an additional master strobe channel and associated macros.

While the disclosure has been described with respect to a limited number of embodiments, those skilled in the art, having benefit of this disclosure, will appreciate that other embodiments may be devised which do not depart from the scope of the disclosure as disclosed herein. The disclosure has been described in detail, it should be understood that various changes, substitutions and alterations can be made hereto without departing from the spirit and scope of the disclosure.

What is claimed is:

1. A luminaire comprising:
 - an array of LED modules generating a directional light beam
 - a first lenslet array
 - a second lenslet array coupled with a first multi-cell louver mask array which can be moved along the light beam
 - a second multi-cell louver mask array where each cell is large enough to contain the area bounded by a plurality of cells from the first louver mask.

* * * * *