



US008408755B2

(12) **United States Patent**
Quadri et al.

(10) **Patent No.:** **US 8,408,755 B2**
(45) **Date of Patent:** **Apr. 2, 2013**

(54) **STAGE LIGHTING FIXTURE AND METHOD OF OPERATING A STAGE LIGHTING FIXTURE**

(75) Inventors: **Pasquale Quadri**, Torre de' Roveri (IT); **Angelo Cavenati**, Brusaporto (IT)

(73) Assignee: **Clay Paky S.p.A.**, Seriate (IT)

(*) Notice: Subject to any disclaimer, the term of this patent is extended or adjusted under 35 U.S.C. 154(b) by 247 days.

(21) Appl. No.: **12/877,607**

(22) Filed: **Sep. 8, 2010**

(65) **Prior Publication Data**

US 2011/0063847 A1 Mar. 17, 2011

(30) **Foreign Application Priority Data**

Sep. 11, 2009 (IT) MI2009A1563

(51) **Int. Cl.**
F21V 9/00 (2006.01)
F21V 14/08 (2006.01)

(52) **U.S. Cl.** **362/321**; 362/293; 362/281

(58) **Field of Classification Search** 362/317, 362/321, 277, 293, 281; 353/97
See application file for complete search history.

(56) **References Cited**

U.S. PATENT DOCUMENTS

3,940,606 A 2/1976 Lemons

4,317,613 A *	3/1982	Grosser	359/370
4,890,208 A *	12/1989	Izenour	362/294
4,899,267 A *	2/1990	Mardon	362/277
5,590,955 A *	1/1997	Bornhorst et al.	362/324
5,788,365 A *	8/1998	Hunt et al.	362/301
6,744,693 B2 *	6/2004	Brockmann et al.	362/321

FOREIGN PATENT DOCUMENTS

DE	517056	3/1929
DE	10229012	1/2004
EP	1001210	5/2000
EP	1158239	11/2001
EP	1482240	12/2004
GB	304274	10/1929

* cited by examiner

Primary Examiner — Peggy A. Neils

(74) *Attorney, Agent, or Firm* — Leason Ellis LLP

(57) **ABSTRACT**

A stage lighting fixture has a casing having a closed first end and an open second end; a light source housed inside the casing, close to the first end, to emit a light beam along an optical axis oriented longitudinally with respect to the casing; an objective optical system located along the optical axis, at the second end of the casing, and having a focus position; a circular-aperture diaphragm located along the optical axis, between the light source and the objective optical system, to intercept the beam; and an iris diaphragm located along the optical axis, between the light source and the objective optical system, and which can be set to the focus position.

16 Claims, 4 Drawing Sheets

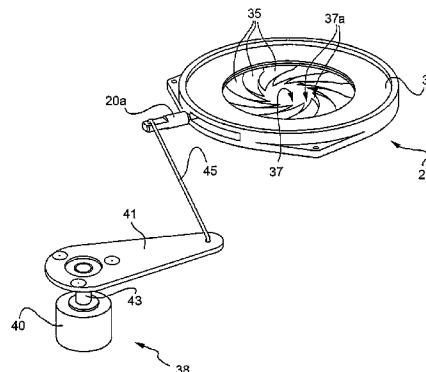
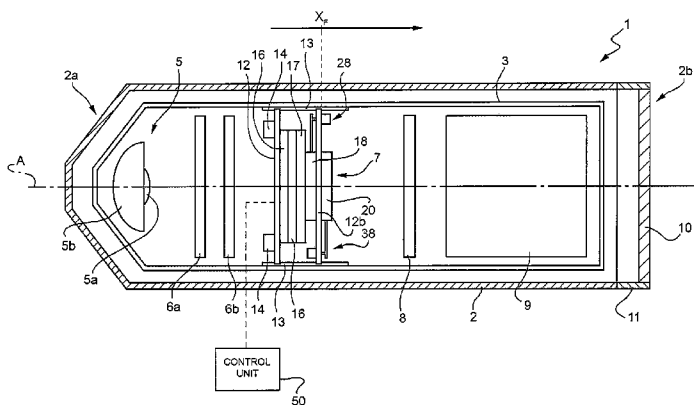

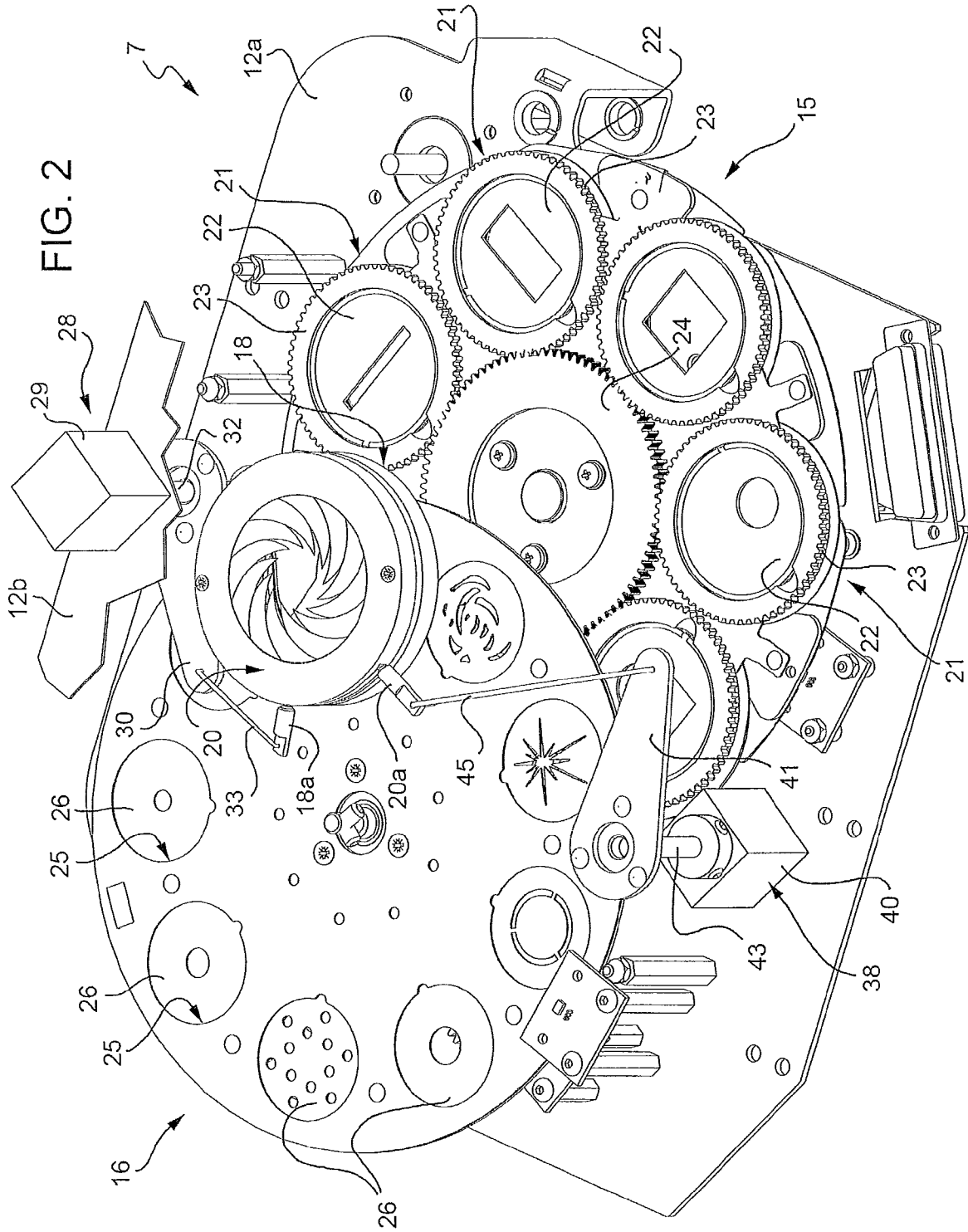

FIG. 3

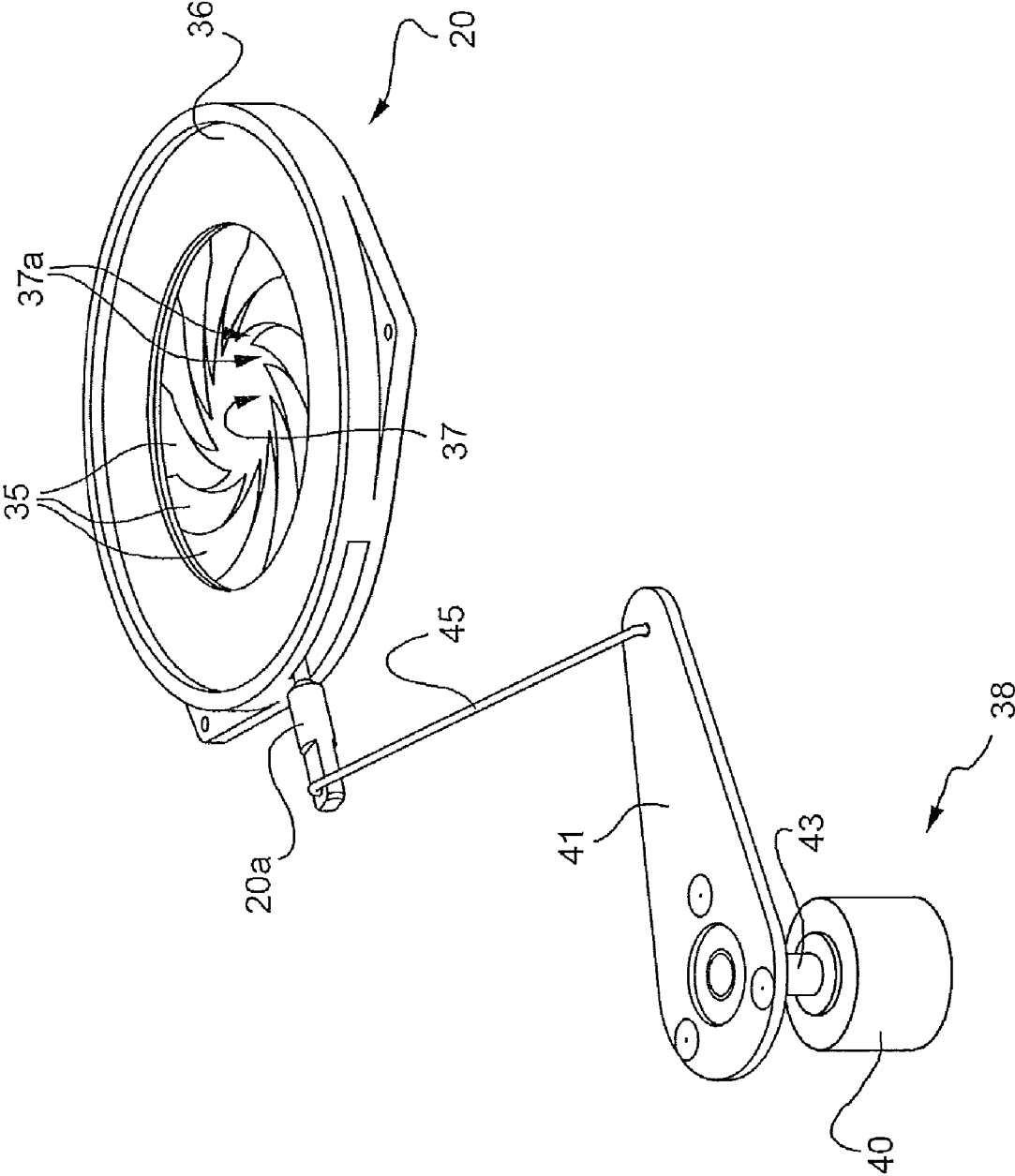
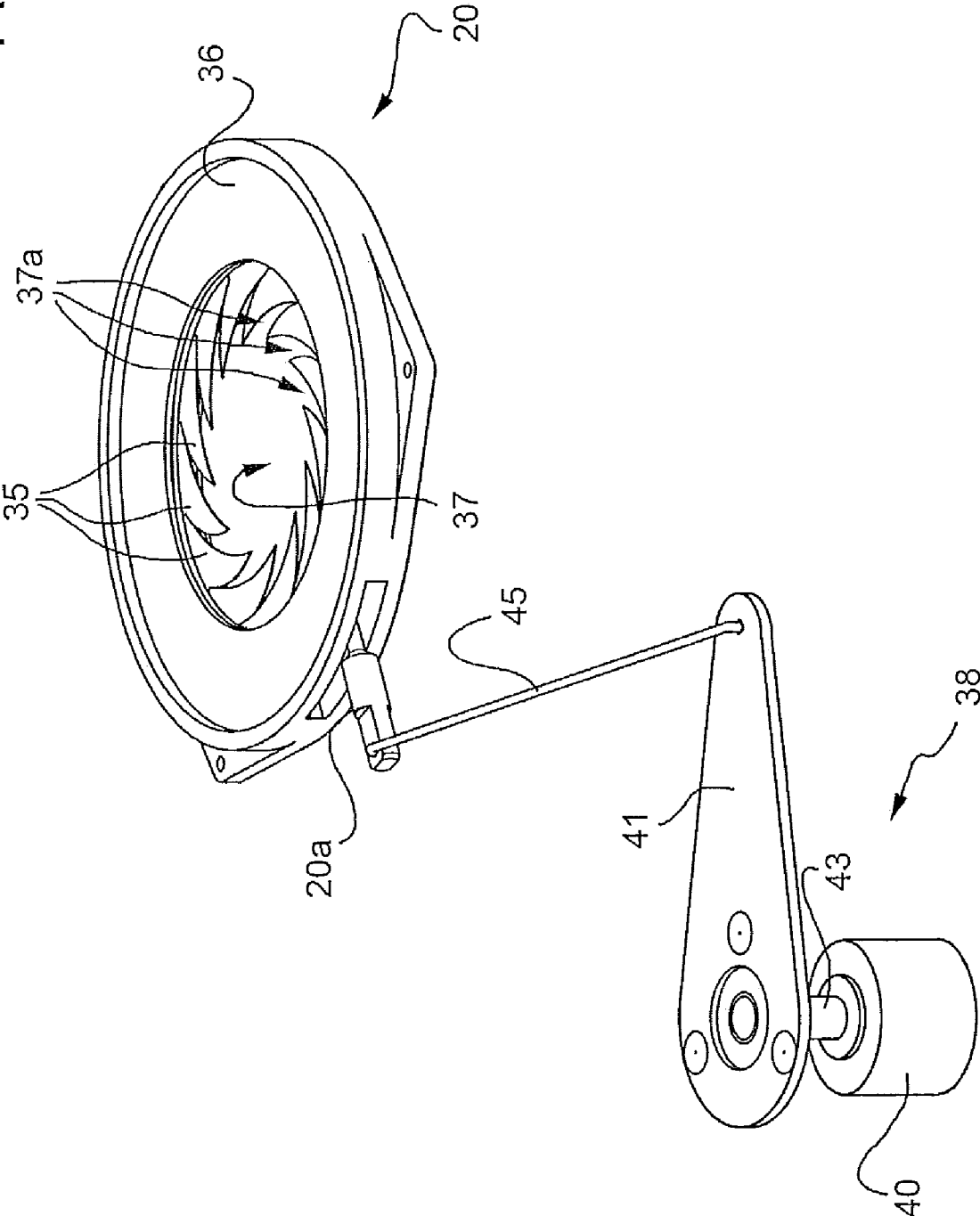

FIG. 4



1

STAGE LIGHTING FIXTURE AND METHOD OF OPERATING A STAGE LIGHTING FIXTURE

The present invention relates to a stage lighting fixture, and
to a method of operating a stage lighting fixture.

BACKGROUND OF THE INVENTION

As is known, a stage lighting fixture comprises a casing
housing a light source, beam filtering and profiling means,
and an objective lens.

The casing extends along a longitudinal axis, is open at one
end, and is closed at the opposite end, where the light source
is located. In actual use, the light source, e.g. a halogen lamp,
emits a beam substantially along the optical axis of the lighting
fixture, which normally coincides with the longitudinal
axis of the casing.

The beam filtering and profiling means are located between
the light source and the objective lens to intercept the beam,
are designed to produce special beam effects, and comprise,
for example, beam colouring assemblies, a diaphragm, a
number of gobos, and other lighting effect devices.

The diaphragm comprises a plurality of movable leaves
fitted to an annular support and substantially located (over-
lapping) in a plane perpendicular to the optical axis. The
leaves are arranged to form a substantially flat shield with a
regular-polygon-shaped or circular central aperture, of which
each leaf defines a side (or arc), and are movable jointly by a
control and actuator to adjust the size of the central aperture.
The diaphragm may be used as a dimmer or profiler to adjust
the brightness or size of the lighting fixture beam respectively.

Gobos are disks, normally of stainless steel or glass,
shaped or patterned to produce given lighting effects when
they intercept the beam.

The objective lens is located at the open end of the casing,
is substantially perpendicular to the optical axis, and is mov-
able to adjust its focus position with respect to the beam
filtering and profiling means.

Known lighting fixtures provide for a fairly wide, but
somewhat limited, range of lighting effects. For example, the
devices normally featured in lighting fixtures are unsuitable
for projecting variable-sized shapes other than convex poly-
gons.

SUMMARY OF THE INVENTION

It is an object of the present invention to provide a stage
lighting fixture, and a method of operating a stage lighting
fixture, designed to produce a wider range of lighting effects.

According to the present invention, there are provided a
stage lighting fixture, and a method of operating a stage
lighting fixture, as claimed in the attached Claims.

BRIEF DESCRIPTION OF THE DRAWINGS

A non-limiting embodiment of the invention will be
described by way of example with reference to the accompa-
nying drawings, in which:

FIG. 1 shows a schematic, longitudinally sectioned side
view of a stage lighting fixture in accordance with one
embodiment of the present invention;

FIG. 2 shows a three-quarter view in perspective, with parts
removed for clarity, of a portion of the FIG. 1 lighting fixture;

FIG. 3 shows an enlarged three-quarter view in perspective
of a detail in FIG. 2 in a first operating configuration;

2

FIG. 4 shows the FIG. 3 detail in a second operating con-
figuration.

DETAILED DESCRIPTION OF THE INVENTION

Number 1 in FIG. 1 indicates as a whole a stage lighting
fixture, which comprises a casing 2 extending along a longi-
tudinal axis, and having a closed first end 2a, and an opposite
open second end 2b. On a frame 3, casing 2 houses a light
source 5, fixed lighting effect devices 6a, 6b, a movable
lighting effect assembly 7, a beam splitter 8, a zoom assembly
9, and an objective lens 10, which are arranged successively
along an optical axis A substantially coincident with the longi-
tudinal axis of casing 2.

Lighting fixture 1 is also equipped with a control unit 50,
which, in the embodiment described, is located outside casing
2 and designed to control light source 5, fixed lighting effect
devices 6a, 6b, movable lighting effect assembly 7, beam
splitter 8, and zoom assembly 9.

Light source 5 is located close to the closed first end 2a of
casing 2, and comprises a lamp 5a, and a parabolic or elliptic
reflector 5b designed to form the light from lamp 5a into a
light beam along optical axis A. The beam travels through
fixed devices 6a, 6b, movable lighting effect assembly 7, and
beam splitter 8, and is projected out through zoom assembly
9 and objective lens 10, which is fixed to the open second end
2b of casing 2, coaxially with axis A. More specifically,
objective lens 10 is fitted to a supporting ring 11 fixed to frame
3; and zoom assembly 9 and objective lens 10 define an
objective optical system with a focus at a focus position X_F
along optical axis A.

Fixed lighting effect devices 6a, 6b are fixed to frame 3,
between light source 5 and movable lighting effect assembly
7, and are known (e.g. may comprise a dimmer and colour
fadeout or colour temperature conversion filters).

Movable lighting effect assembly 7 comprises a plurality
of beam filtering and profiling devices fitted to a carriage 12
movable along guides 13 fixed to frame 3.

In the embodiment described, the beam filtering and pro-
filing devices comprise, in succession, a first rotary-gobo
plate 15, a fixed-gobo plate 16, a second rotary-gobo plate 17,
a circular- or polygonal-aperture diaphragm 18 (hereinafter
referred to simply as a circular diaphragm), and an iris dia-
phragm 20, all described in detail below. It is understood,
however, that carriage 12 may be fitted with other types of
devices for producing different lighting effects when traver-
sed by the beam.

Carriage 12 is located between light source 5 and objective
lens 10, and is driven by on-board electric motors 14 con-
trolled by control unit 50 to move carriage selectively into a
plurality of positions along optical axis A. More specifically,
carriage 12 may be positioned with one beam filtering and
profiling device located at objective optical system focus
position X_F , and the other beam filtering and profiling devices
in respective out-of-focus positions; and may be positioned to
use circular diaphragm 18 out of focus, to adjust the intensity
of the beam (i.e. as a dimmer).

Beam splitter 8 is located along optical axis A, downstream
from movable lighting effect assembly 7, and, in one embodi-
ment, is a rotating prism for dividing the incident beam into a
plurality of sub-beams.

Going back to the beam filtering and profiling devices,
FIG. 2, in which parts are removed for clarity, shows a sup-
porting portion 12a of carriage 12, first rotary-gobo plate 15,
fixed-gobo plate 16, circular diaphragm 18, and iris dia-
phragm 20. Supporting portion 12a has a central opening (not
shown in FIG. 2) to let the beam through.

First rotary-gobo plate **15** is fitted to carriage **12** to rotate about a central axis (not shown) parallel to and offset with respect to optical axis A, and comprises a plurality of gobo holders **21** housing respective gobos **22** and arranged in a circle intersecting optical axis A, so each gobo **22** can be selectively positioned to intercept the beam. Each gobo holder **21** rotates about a respective axis perpendicular to first rotary-gobo plate **15**, and has a respective peripheral gear **23**, which meshes with a central gear **24** coaxial with and rotated with respect to first rotary-gobo plate **15** by a known actuator not shown. Second rotary-gobo plate **17** is substantially identical to first rotary-gobo plate **15** and therefore not shown.

Fixed-gobo plate **16** is fitted to carriage **12** to rotate about a central axis (not shown) parallel to and offset with respect to optical axis A, and comprises a plurality of seat **25** housing respective fixed gobos **26** and arranged in a circle intersecting optical axis A, so each gobo **26** can be positioned selectively to intercept the beam. Fixed-gobo plate **16** is also operated by an actuator not shown.

Circular diaphragm **18** and iris diaphragm **20** are fitted to a supporting portion **12b** of carriage **12** (shown schematically in FIG. **1** and only partly in FIG. **2** for the sake of clarity).

Circular diaphragm **18** is a conventional type, is coaxial with optical axis A, and has a control **18a** for adjusting its aperture. An actuator **28**—comprising a step motor **29**, a crank **30** fitted to a shaft **32** of step motor **29**, and a connecting rod **33** connected to control **18a**—is controlled by control unit **50** to adjust the aperture of circular diaphragm **18**, and is fitted to supporting portion **12b** of carriage **12** (FIG. **1**).

Iris diaphragm **20** is fitted to carriage **12**, coaxially with optical axis A and adjacent to circular diaphragm **18**.

The term “iris diaphragm” is intended here to mean any diaphragm comprising a plurality of substantially coplanar leaves connected at one end to a supporting frame, and the free ends of which do not overlap, so that, in other than the fully closed position, the free ends of pairs of adjacent leaves are separated by spaces through which light can pass, and the leaves define a non-convex aperture comprising a central region and peripheral regions, defined by non-overlapping ends of adjacent leaves and radiating or spiraling about the central region. Iris diaphragms are known, and are normally used, in out-of-focus positions, in filming or photographic equipment to adjust exposure. and instead of circular diaphragms to attenuate fading, characteristic of circular diaphragms, along the edges of the image.

In the FIGS. **3** and **4** embodiment, iris diaphragm **20** comprises a plurality of leaves **35** fitted to an annular support **36** so that their respective free ends do not overlap, and which are designed and positioned to define a star aperture **37**. More specifically, aperture **37** comprises a clear central region; and spiral-shaped peripheral regions **37a** defined between non-overlapping portions of adjacent leaves **35**. In other words, portions of leaves **35** alternate with peripheral regions **37a** of aperture **37** along a circle concentric with aperture **37** and larger in radius than the clear central region of aperture **37**.

The size of aperture **37** is adjusted by a control **20a** operated by an actuator **38** fitted to supporting portion **12b** of carriage **12** (FIG. **1**). More specifically, actuator **38** comprises a step motor **40**; a crank **41** fitted to a shaft **43** of step motor **40**; and a connecting rod **45** connected to control **20a** controlling iris diaphragm **20**. Like motors **14** of carriage **12**, and the actuators of the gobo plates and circular diaphragm **18**, actuator **38** of iris diaphragm **20** is also controlled by control unit **50**, which determines the size and adjustment rate of aperture **37** of iris diaphragm **20**. In FIGS. **3** and **4**, the iris diaphragm is shown in the minimum- and maximum-aperture configuration respectively.

In actual use, control unit **50** of lighting fixture **1** determines the position of carriage **12** and the devices fitted to it. Whereas circular diaphragm **18** is also used in an out-of-focus position to adjust the intensity of the beam, the first and second rotary-gobo plates **15**, **17**, fixed-gobo plate **16**, and iris diaphragm **20** are used in focus position X_F .

More specifically, iris diaphragm **20** is used in focus position X_F to shape the beam to achieve a special effect defined by a projected image of the same configuration as aperture **37**; and the size of the projected image is adjustable, like that aperture **37**.

When iris diaphragm **20** is in focus position X_F , the circular diaphragm is preferably maintained in the maximum-aperture configuration.

Combined with beam splitter **8**, the effect can be multiplied to project a plurality of images of the same configuration as aperture **37**.

When not in use, iris diaphragm **20** is positioned out of focus, is set to the maximum-aperture configuration, and has substantially no effect on the beam.

Clearly, changes may be made to the lighting fixture and method as described herein without, however, departing from the scope of the present invention, as defined in the accompanying Claims.

In particular, in one embodiment not shown, the iris diaphragm is fixed in the beam focus position.

In another embodiment not shown, the iris diaphragm is seated in a plate, e.g. a gobo plate, and is controlled by a toroidal motor on the plate itself.

In another embodiment not shown, the control unit is housed inside the casing and connectable to the outside by a connector.

The lighting fixture may obviously feature other devices, in addition to or instead of those described, to produce other lighting effects (stroboscopic, wind, etc.). For example, the iris diaphragm may be used in combination with a beam profiler, as opposed (or in addition) to gobo plates.

The invention claimed is:

1. A stage lighting fixture comprising:

a casing having a closed first end and an open second end; a light source housed inside the casing, close to the first end, to emit a light beam along an optical axis (A);

an objective optical system located along the optical axis, at the second end of the casing, and having a focus position (X_F); and

a circular-aperture diaphragm located along the optical axis (A), between the light source and the objective optical system, to intercept the beam;

and characterized by an iris diaphragm located along the optical axis (A), between the light source and the objective optical system, and which can be set to the focus position (X_F), wherein the iris diaphragm comprises a plurality of substantially coplanar leaves connected at one end to a supporting frame, and free ends thereof do not overlap so that the free ends of pair of adjacent leaves are separated by spaced through which light can pass.

2. A lighting fixture as claimed in claim **1**, wherein the circular-aperture diaphragm and the iris diaphragm are movable between the focus position (X_F) and respective out-of-focus positions.

3. A lighting fixture as claimed in claim **2**, comprising a control unit and positioning means controlled by the control unit for positioning the iris diaphragm alternatively at the focus position (X_F) and at least at the respective out-of-focus positions.

4. A lighting fixture as claimed in claim **3**, wherein the positioning means comprise a carriage, movable on guides

5

along the optical axis (A), and a motor and wherein the circular-aperture diaphragm and the iris diaphragm are fitted to the carriage.

5 **5.** A lighting fixture as claimed in claim 1, comprising an actuator; wherein the iris diaphragm has an adjustable aperture and an aperture control member; and wherein the actuator is connected to the aperture control member of the iris diaphragm.

10 **6.** A lighting fixture as claimed in claim 3, comprising an actuator; wherein the iris diaphragm has an adjustable aperture and an aperture control member; wherein the actuator is connected to the aperture control member of the iris diaphragm; and wherein the actuator is controlled by the control unit.

15 **7.** A lighting fixture as claimed in claim 6, wherein the control unit is configured to control an adjustment rate of the aperture of the iris diaphragm.

20 **8.** A lighting fixture as claimed in claim 1, comprising a beam splitter located along the optical axis (A), between the iris diaphragm and the objective optical system, for splitting the beam into a plurality of sub-beams.

9. A method for operating a stage lighting fixture, comprising:

25 projecting a light beam from a light source through a circular-aperture diaphragm and an objective optical system aligned with each other along an optical axis (A); characterized by positioning an iris diaphragm along the optical axis (A), between the light source and the objec-

6

tive optical system, at a focus position (X_F) of the objective optical system, wherein the iris diaphragm comprises a plurality of substantially coplanar leaves connected at one end to a supporting frame, and free ends thereof do not overlap so that the free ends of pair of adjacent leaves are separated by spaced through which light can pass.

10. A method as claimed in claim 9, comprising positioning the iris diaphragm alternatively at the focus position (X_F) and at least at an out-of-focus position.

11. A method as claimed in claim 9, comprising adjusting an aperture of the iris diaphragm.

12. A method as claimed in claim 11, comprising controlling an adjustment rate of the aperture of the iris diaphragm.

15 **13.** A method as claimed in claim 9, comprising splitting the beam into a plurality of sub-beams.

14. A method as claimed in claim 13, wherein splitting the beam comprises placing a beam splitter along the optical axis (A), between the iris diaphragm and the objective optical system.

15. A lighting fixture as claimed in claim 1, wherein the leaves define a non-convex aperture.

16. A lighting fixture as claimed in claim 1, wherein the leaves are configured and positioned to define a star aperture having a clear channel region and spiral-shaped peripheral regions, defined between non-overlapping portions of adjacent leaves.

* * * * *