



US008063906B2

(12) **United States Patent**  
**Belliveau et al.**

(10) **Patent No.:** **US 8,063,906 B2**  
(45) **Date of Patent:** **Nov. 22, 2011**

(54) **MULTIPARAMETER STAGE LIGHTING APPARATUS WITH GRAPHICAL OUTPUT**

(75) Inventors: **Richard S. Belliveau**, Austin, TX (US);  
**Thomas Edward Grimes**, Austin, TX (US)

(73) Assignee: **Barco Lighting Systems, Inc.**, Austin, TX (US)

(\* ) Notice: Subject to any disclaimer, the term of this patent is extended or adjusted under 35 U.S.C. 154(b) by 855 days.

(21) Appl. No.: **12/123,514**

(22) Filed: **May 20, 2008**

(65) **Prior Publication Data**

US 2009/0190346 A1 Jul. 30, 2009

**Related U.S. Application Data**

(63) Continuation-in-part of application No. 12/020,038, filed on Jan. 25, 2008.

(51) **Int. Cl.**

**G06T 13/00** (2011.01)  
**G06T 15/00** (2011.01)  
**G06F 3/038** (2006.01)  
**G06F 1/00** (2006.01)  
**H05B 37/00** (2006.01)  
**B60Q 1/26** (2006.01)  
**F21V 9/00** (2006.01)

(52) **U.S. Cl.** ..... **345/473**; 345/419; 345/204; 315/291; 315/320; 362/231; 362/232; 362/227

(58) **Field of Classification Search** ..... None  
See application file for complete search history.

(56) **References Cited**

**U.S. PATENT DOCUMENTS**

4,392,187 A 7/1983 Bornhorst ..... 362/233  
4,962,687 A 10/1990 Belliveau et al. .... 84/464 R  
5,752,766 A 5/1998 Baily ..... 362/250

6,016,038 A 1/2000 Mueller et al. .... 315/291  
6,357,893 B1 3/2002 Belliveau ..... 362/285  
6,908,214 B2\* 6/2005 Luk ..... 362/249.02  
2003/0057887 A1\* 3/2003 Dowling et al. .... 315/291  
2003/0112148 A1\* 6/2003 Belliveau ..... 340/825.71  
2006/0158461 A1\* 7/2006 Reese et al. .... 345/620

**OTHER PUBLICATIONS**

Product-Easy Color- PDF <http://www.aryton-light.com/download/productsspecific/easycol2.specif.uk.pdf>, Aryton located in Longjumeau, France, 2006.  
High End Systems Brochure 2000.  
ProLight Opto Technology Corporation, ProLight PG1X-3LIFE, 3W RGB Power LED, Technical Datasheet, Version 2.6, 12 pages, 2006.  
U.S. Appl. No. 11/516,822, filed Sep. 27, 2006, Belliveau.

\* cited by examiner

*Primary Examiner* — Xiao M. Wu

*Assistant Examiner* — Tize Ma

(74) *Attorney, Agent, or Firm* — Walter J. Tencza, Jr.

(57) **ABSTRACT**

A multiparameter stage lighting apparatus is provided comprising a lamp housing, which may include a plurality of sets of light emitting diodes, each set of light emitting diodes having a plurality of colors, the plurality of sets of light emitting diodes forming an additive color mixing system. The multiparameter stage lighting apparatus may further include a plurality of pie shaped light emitting circuit boards, one light emitting circuit board for each set of the plurality of sets of light emitting diodes, each set of the plurality of sets of light emitting diodes mounted to its respective light emitting circuit board. The multiparameter stage lighting apparatus may further include a plurality of light emitting diode signaling circuit boards, one for each of the plurality of pie shaped light emitting circuit boards. Each of the plurality of light emitting diode signaling circuit boards may be connected to its corresponding pie shaped light emitting circuit boards by a corresponding one of a plurality of multiconductor cables.

**10 Claims, 9 Drawing Sheets**

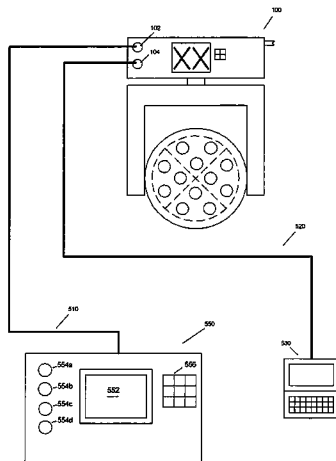

FIG 1

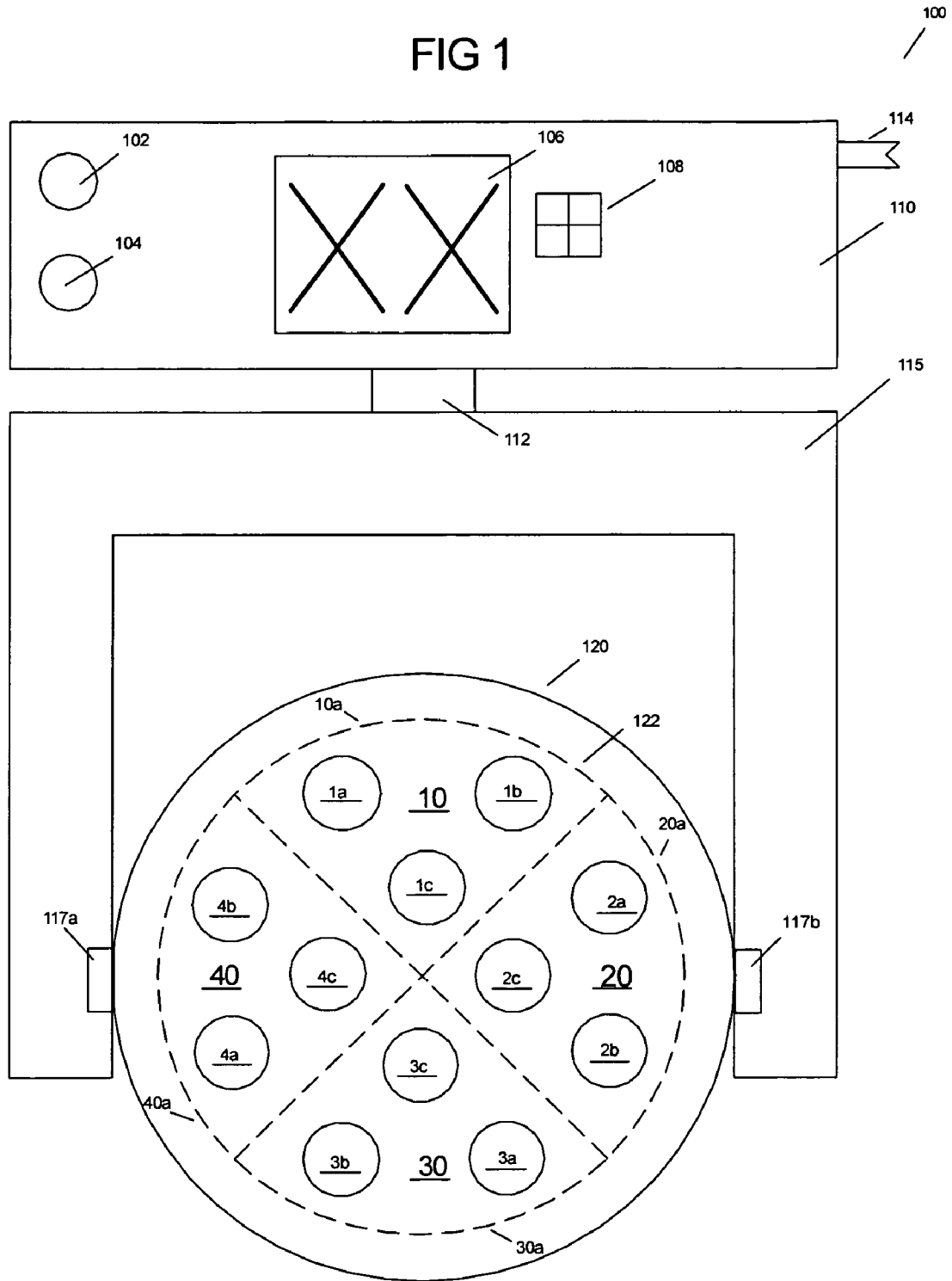

FIG 2

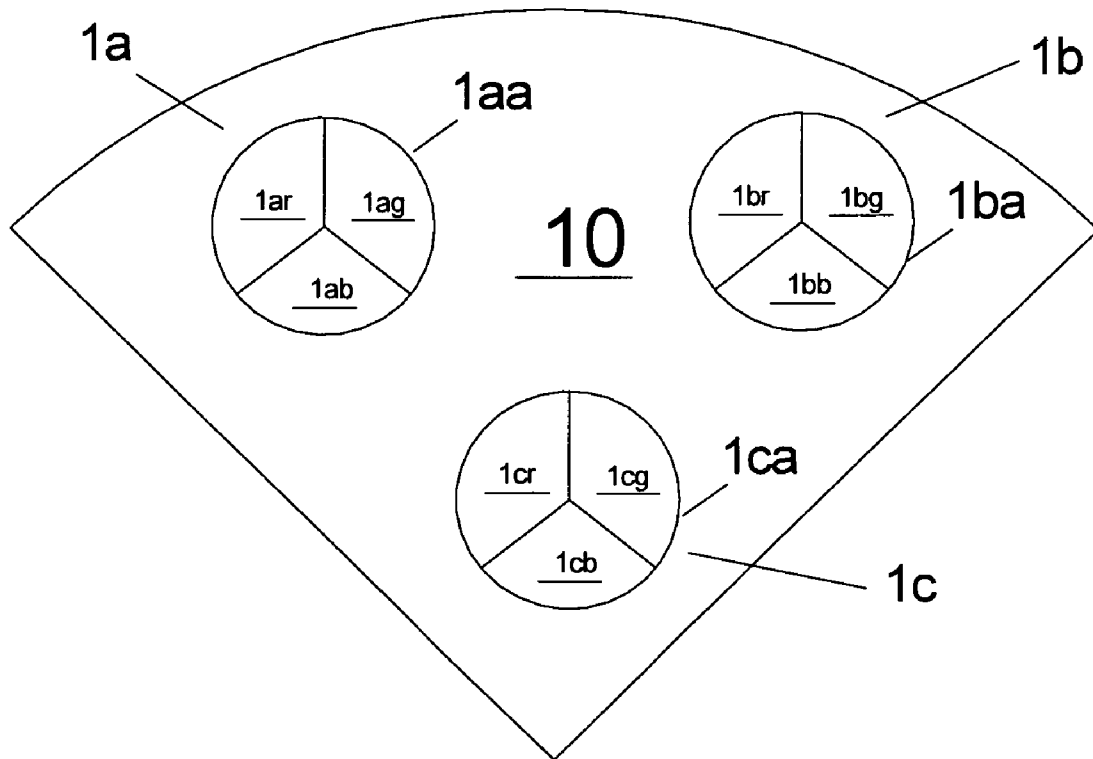

FIG 3

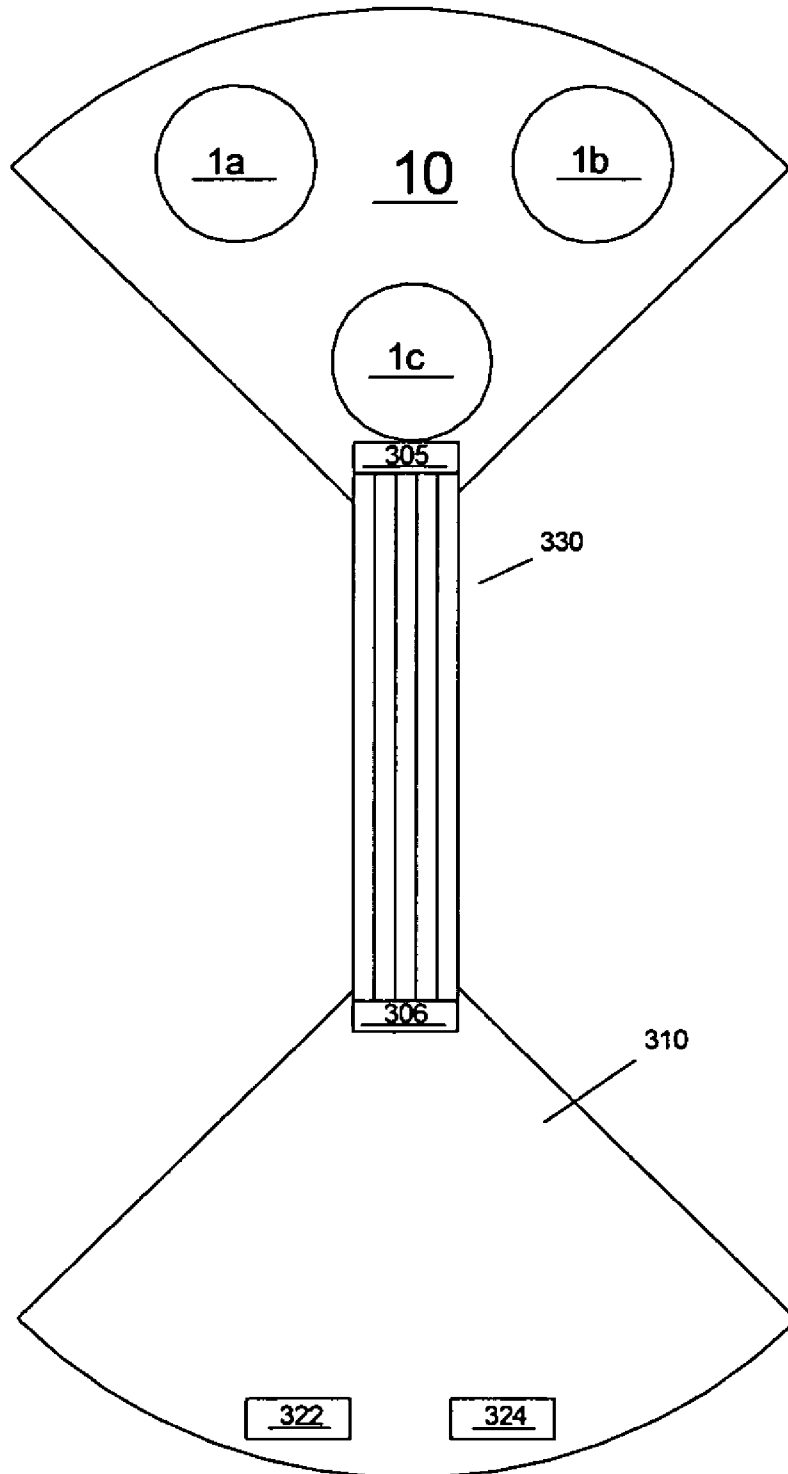

FIG 4

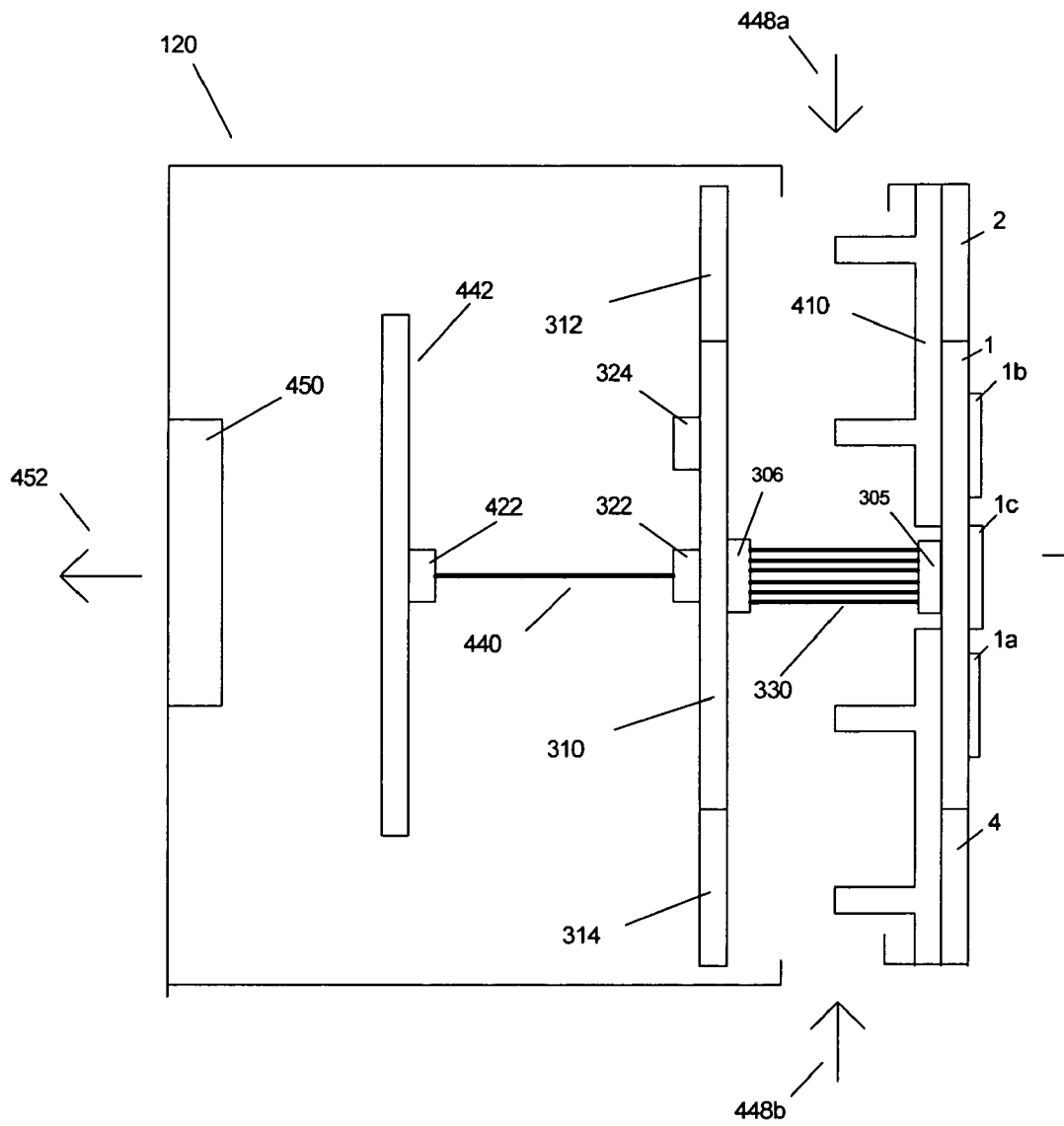

FIG 5

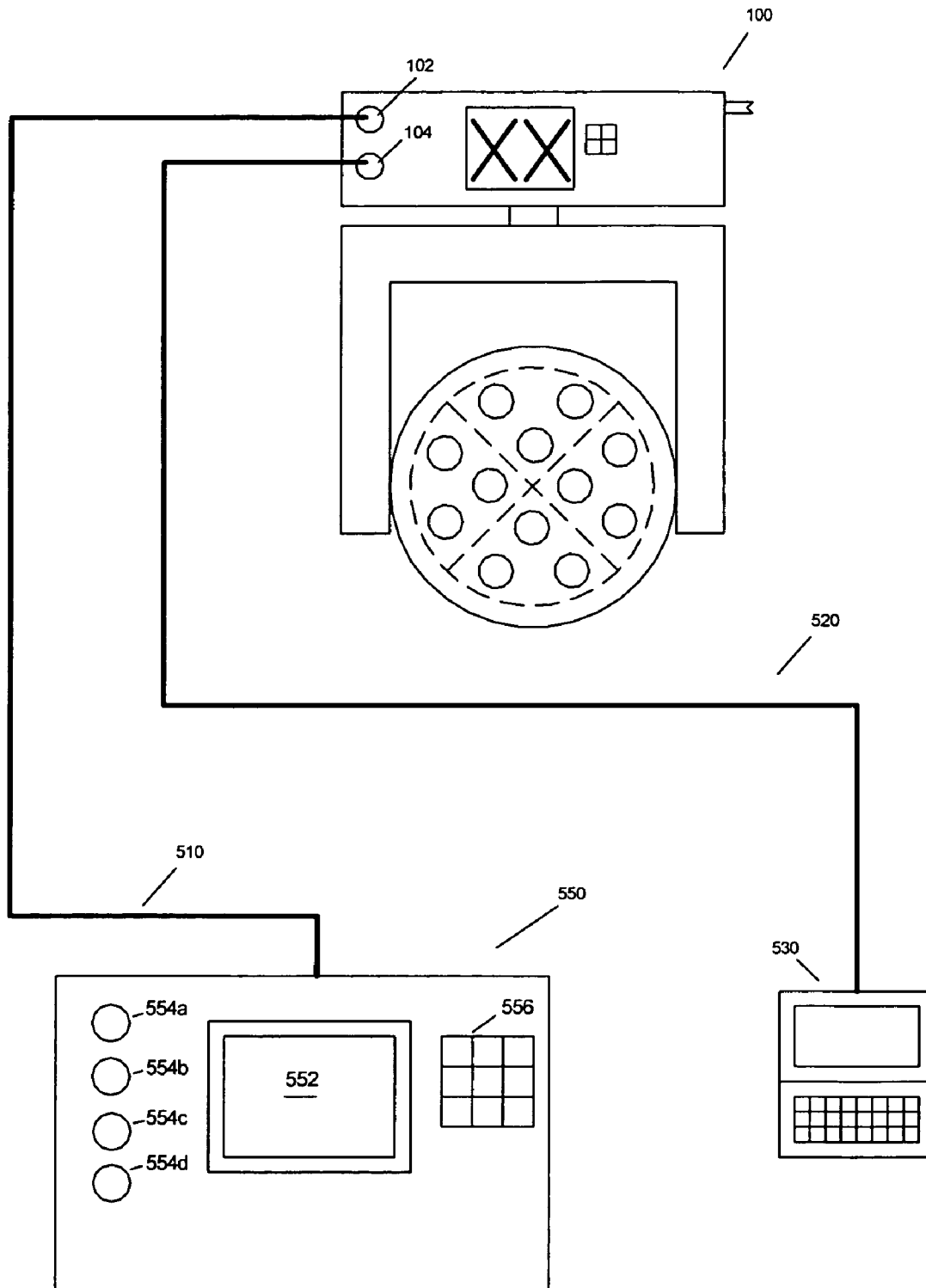

FIG 6

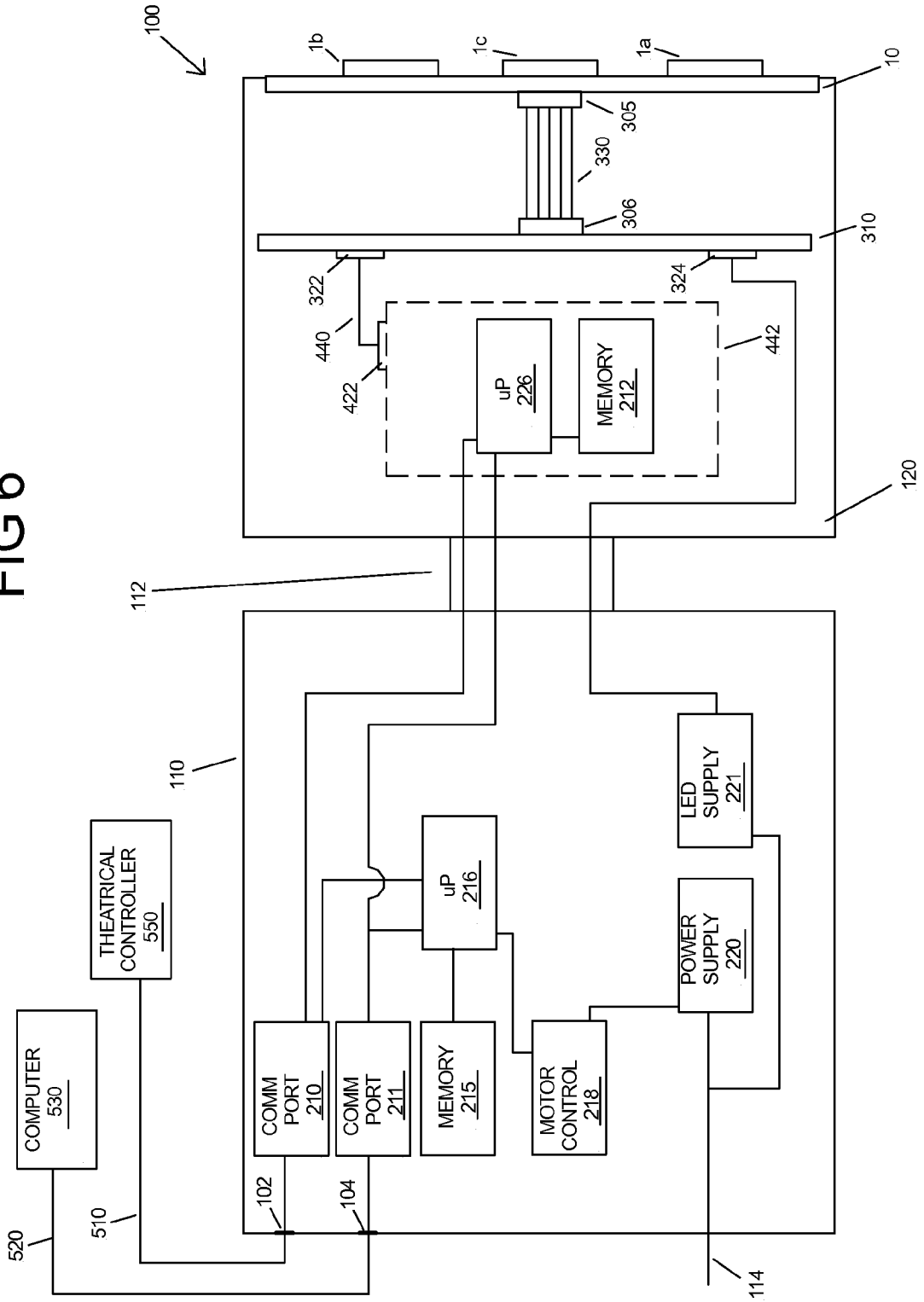

FIG 7

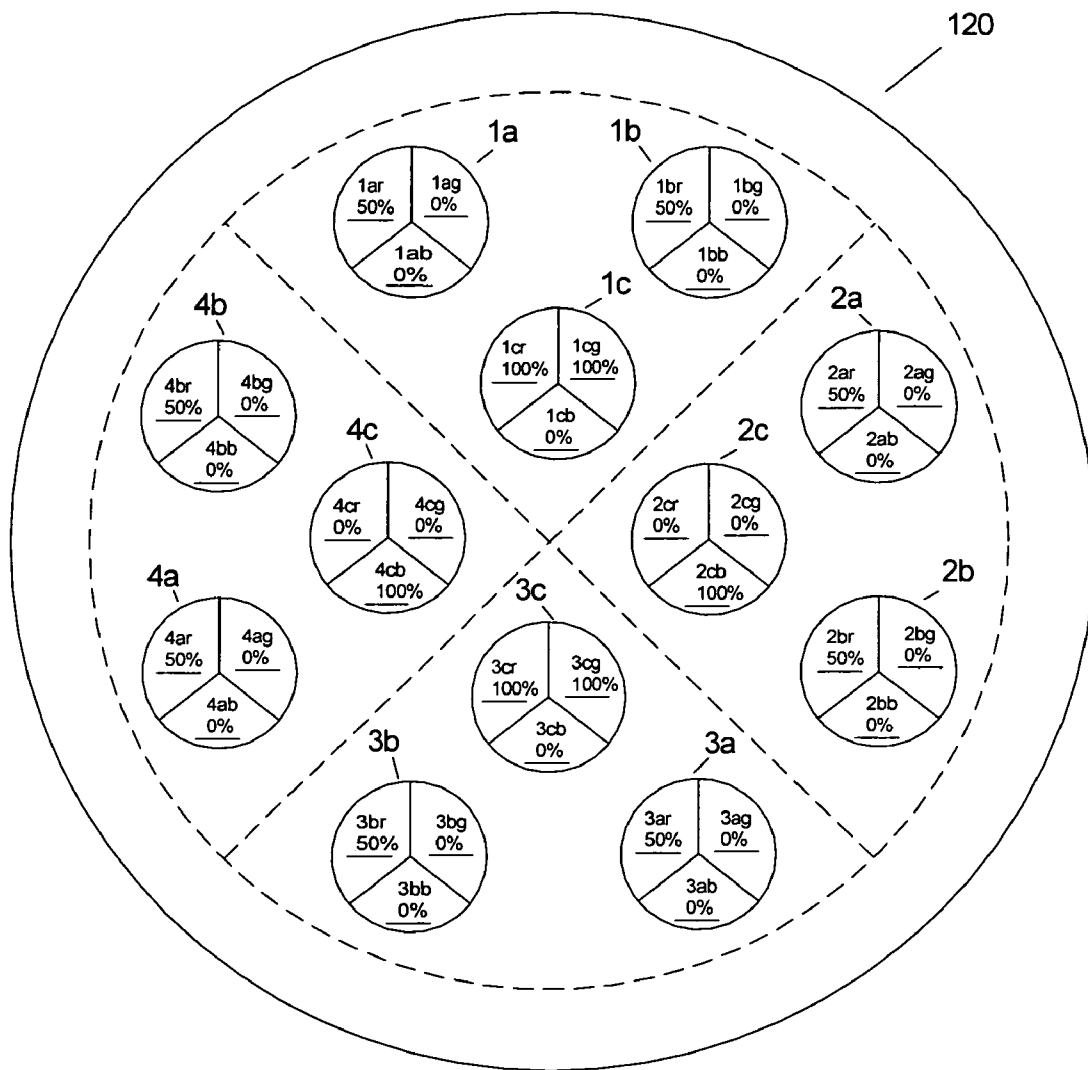

FIG 8

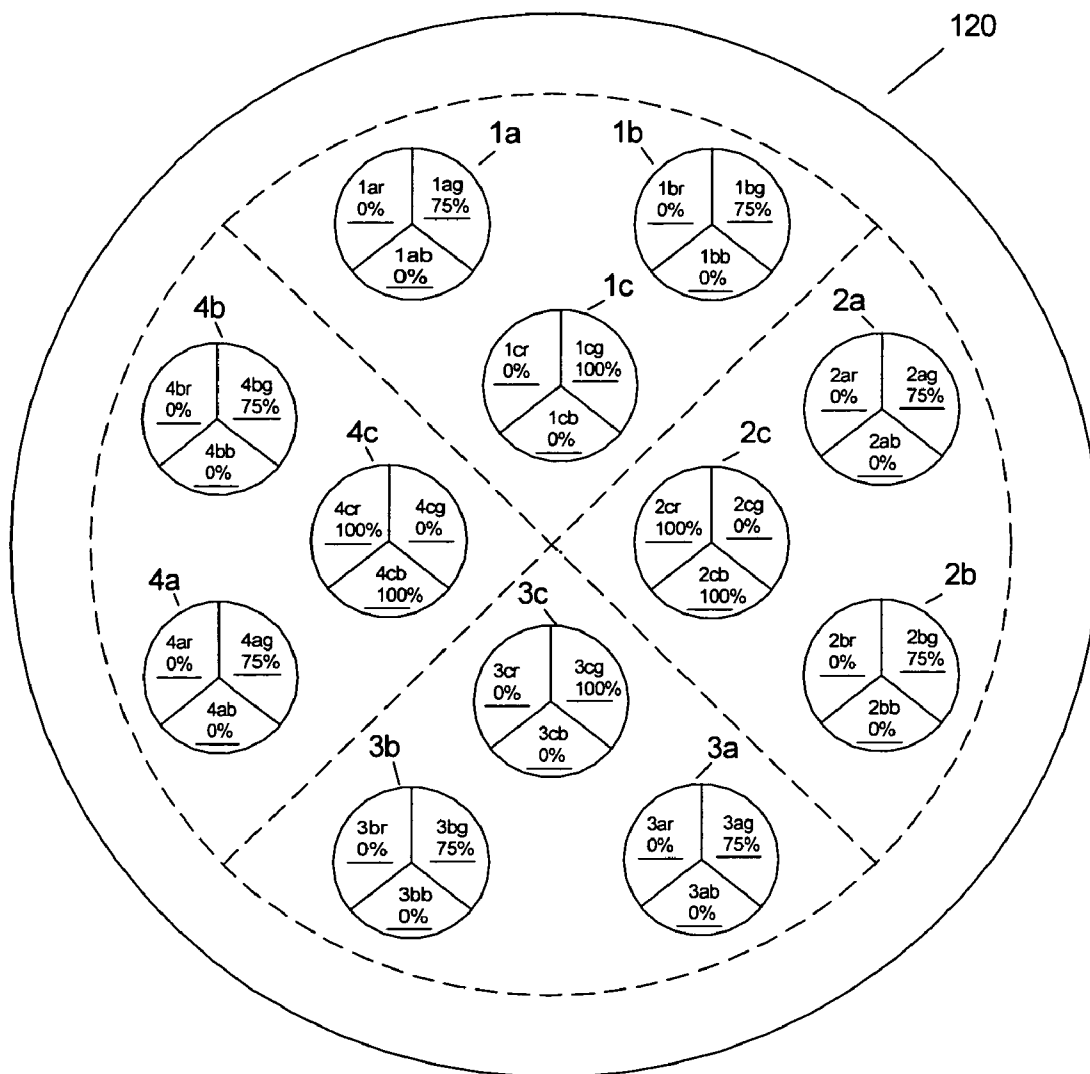

FIG 9A

DMX channels = 256

Second animated GCP = two frames

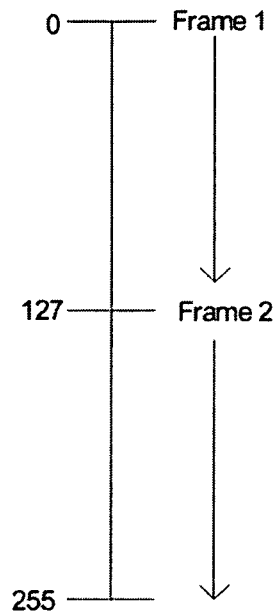
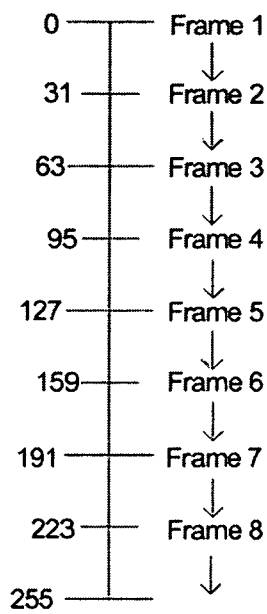

FIG 9B

DMX channels = 256

Third animated GCP = eight frames



## MULTIPARAMETER STAGE LIGHTING APPARATUS WITH GRAPHICAL OUTPUT

### CROSS REFERENCE TO RELATED APPLICATION(S)

The present application is a continuation in part of and claims the priority of U.S. patent application Ser. No. 12/020,038, titled "MULTIPARAMETER STAGE LIGHTING APPARATUS WITH GRAPHICAL OUTPUT", filed on Jan. 25, 2008.

### FIELD OF THE INVENTION

This invention relates to multiparameter stage lighting fixtures.

### BACKGROUND OF THE INVENTION

Multiparameter lighting fixtures are lighting fixtures, which illustratively have two or more individually remotely adjustable parameters such as focus, color, image, position, or other light characteristics. Multiparameter lighting fixtures are widely used in the lighting industry because they facilitate significant reductions in overall lighting system size and permit dynamic changes to the final lighting effect. Applications and events in which multiparameter lighting fixtures are used to great advantage include showrooms, television lighting, stage lighting, architectural lighting, live concerts, and theme parks. Illustrative multi-parameter lighting fixtures are described in the product brochure showing the High End Systems product line for the year 2000 and are available from High End Systems, Inc. of Austin, Tex.

Multiparameter lighting fixtures are commonly constructed with a lamp housing that may pan and tilt in relation to a base housing so that light projected from the lamp housing can be remotely positioned to project on the stage surface. Commonly a plurality of multiparameter lights are controlled by an operator from a central controller. The central controller is connected to communicate with the plurality of multiparameter lights via a communication system. U.S. Pat. No. 4,392,187 titled "Computer controlled lighting system having automatically variable position, color, intensity and beam divergence" to Bornhorst and incorporated herein by reference, disclosed a plurality of multiparameter lights and a central controller.

The lamp housing of the multiparameter light contains the optical components and the lamp. The lamp housing is rotatably mounted to a yoke that provides for a tilting action of the lamp housing in relation to the yoke. The lamp housing is tilted in relation to the yoke by a motor actuator system that provides remote control of the tilting action by the central controller. The yoke is rotatably connected to the base housing that provides for a panning action of the yoke in relation to the base housing. The yoke is panned in relation to the base housing by a motor actuator system that provides remote control of the panning action by the central controller.

Multiparameter lights may be constructed with various light sources. U.S. Pat. No. 6,357,893 to Belliveau, incorporated by reference herein, discloses various multiparameter lighting devices that have been constructed using light emitting diodes (LEDs) as light sources. U.S. Pat. No. 6,357,893 to Belliveau discloses a multiparameter light constructed of a plurality of LEDs that can individually vary the intensity of the light sources of the same wavelength or color in relation to each other.

U.S. patent application Ser. No. 11/516,822, to Belliveau, filed on Sep. 27, 2006, incorporated by reference herein, discloses that a plurality of LEDs may be constructed of a plurality of red, green and blue LEDs. In that application, a red, green and blue LED of the plurality of LEDs may be constructed as to emit their combined light from a single output aperture that produces an homogenous color blend to the eye.

### SUMMARY OF THE INVENTION

One or more embodiments of the present invention disclose a multiparameter stage lighting fixture constructed of a plurality of multiple wavelength LEDs. It has been found by the inventors of this application that a multiparameter stage lighting fixture of an embodiment of the present invention can be constructed of a system and method that can provide creative graphical control over a plurality of LED light sources.

In at least one embodiment of the present invention a multiparameter stage lighting apparatus is provided comprising a lamp housing. The lamp housing may be comprised of a plurality of sets of light emitting diodes, each set of light emitting diodes having a plurality of colors, the plurality of sets of light emitting diodes forming an additive color mixing system. The multiparameter stage lighting apparatus may further include a plurality of pie shaped light emitting circuit boards, one light emitting circuit board for each set of the plurality of sets of light emitting diodes, each set of the plurality of sets of light emitting diodes mounted to its respective light emitting circuit board. The multiparameter stage lighting apparatus may further include a plurality of light emitting diode signaling circuit boards, one for each of the plurality of pie shaped light emitting circuit boards. A plurality of multiconductor cables may also be provided, one for each of the plurality of pie shaped light emitting circuit boards. Each of the plurality of light emitting diode signaling circuit boards may be connected to its corresponding pie shaped light emitting circuit boards by a corresponding one of the plurality of multiconductor cables. The multiparameter stage lighting apparatus may further include a base housing. The lamp housing may be remotely positionable in relation to the base housing.

Each of the plurality of multiconductor cables may be a multiconductor flat cable. Each of the plurality of light emitting diode signaling circuit boards may be shaped in a pie shape. The multiparameter stage lighting apparatus may further include a communications port, and a memory. The communications port may receive a first graphical content program and the memory may store the first graphical content program.

### BRIEF DESCRIPTION OF THE DRAWINGS

FIG. 1 shows a multiparameter light in accordance with an embodiment of the present invention, with the a plurality of LED mounting substrates or a plurality of LED light emitting circuit boards;

FIG. 2 shows one of the plurality of LED mounting substrates of FIG. 1;

FIG. 3 shows the LED mounting substrate of FIG. 2 interconnected to an LED drive or signaling circuit board

FIG. 4 shows a lamp housing of the multiparameter light of FIG. 1, incorporating the LED drive or signaling circuit board of FIG. 3 and the LED mounting substrate of FIG. 3.

FIG. 5 shows a control system for operation of the multiparameter light of FIG. 1;

FIG. 6 shows the internal electronic components of the multiparameter light of FIG. 1;

FIG. 7 shows the resultant illumination of a plurality of LEDs of the multiparameter light of FIG. 1 when the multiparameter light responds to a first frame of a first graphical content program of data stored in a memory of FIG. 6;

FIG. 8 shows a resultant illumination of the plurality of LEDs of the multiparameter light of FIG. 1 when the multiparameter light responds to a second frame of data for the first graphical content program of data stored in the memory of FIG. 6;

FIG. 9A shows a GCP having two frames of animation that has been scaled to a DMX control channel having two hundred fifty-six values; and

FIG. 9B shows a GCP with eight frames of animation.

#### DETAILED DESCRIPTION OF THE DRAWINGS

In the description that follows, like parts are marked throughout the specification and drawings with the same reference numerals, respectively. The drawing figures are not necessarily to scale. Certain features of embodiments of the present invention may be shown exaggerated in scale or in somewhat schematic form and some details of conventional elements may not be shown in the interest of clarity and conciseness. The present invention is susceptible to embodiments of different forms. There are shown in the drawings, and herein will be described in detail, specific embodiments of the present invention with the understanding that the present disclosure is to be considered an exemplification of the principles of the invention, and is not intended to limit the invention to that illustrated and described herein. It is to be fully recognized that the different teachings of the embodiments discussed below may be employed separately or in any suitable combination to produce the desired results.

In particular, various embodiments of the present invention provide a number of different methods and apparatus for operating and controlling multiparameter stage lights. The concepts of the invention are discussed in the context of multiparameter lighting stage lights but the use of the concepts of the present invention is not limited to multiparameter stage lights and may find application in other lighting and other visual systems where control of the system is maintained from a remote location and to which the concepts of the current invention may be applied.

FIG. 1 shows a multiparameter light 100 in accordance with an embodiment of the present invention. The multiparameter light 100 includes a lamp housing 120 and a base housing 110. The multiparameter light 100 is capable of remotely panning and tilting the lamp housing 120 in relation to the base housing 110. The lamp housing 120 is mounted by bearings 117a and 117b so that the lamp housing 120 can tilt in relation to the yoke 115. The yoke 115 is attached to the base housing 110 by bearing 112 that allows the yoke 115 and the lamp housing 120 to pan in relation to the base housing 110. The lamp housing 120 is remotely tilted in relation to the yoke 115 by a first motor actuator (not shown for simplicity). The yoke 115 is remotely panned in relation to the base housing 110 by a second motor actuator (not shown for simplicity).

A first communication connector 102 and a second communication connector 104 are shown mounted to the base housing 110. An alpha numeric display 106 and an input keypad 108 are shown as components of the base housing 110. A section of a mains input power cord 114 is shown as a component of the base housing 110.

The lamp housing 120 shows four LED emitting circuit boards 10, 20, 30 and 40 as components of the lamp housing as shown by dashed lines. The LED emitting circuit boards 10, 20, 30, and 40 may be configured so that they are physically separate, i.e. not attached together or are easily detachable from one another. The LED emitting circuit boards 10, 20, 30, and 40 may also be configured and/or shaped so that while separate, or easily separable, they can come together or fit together as a unit. For example the emitting circuit boards 10, 20, 30, and 40 of FIG. 1 are pie shaped so that they can fit together in one circular shape. The four LED emitting circuit boards 10, 20, 30, and 40 are shaped into pie-shaped circuit boards with the radial component of each board shown by 10a, 20a, 30a and 40a used to form circumference 122. The circuit boards could also be shaped as a triangle (not shown) instead of being shaped pie-shaped but then the circumference 122 would become a polygon. LED emitting circuit board 10 has a plurality of LEDs 1a, 1b and 1c mounted thereon. LED emitting circuit board 20 has a plurality of LEDs 2a, 2b and 2c mounted thereon. LED emitting circuit board 30 has a plurality of LEDs 3a, 3b and 3c mounted thereon. LED emitting circuit board 40 has a plurality of LEDs 4a, 4b and 4c mounted thereon.

FIG. 2 shows LED emitting circuit board 10 which is the same as LED circuit board 10 of FIG. 1. LEDs 1a, 1b, and 1c are shown in more detail. LED 1a is comprised of three separate LED dies 1ar, 1ag and 1ab; and a round aperture 1aa. The LED dies 1ar, 1ag, and 1ab are red, green, and blue LED dies, that emit red, green, and blue light, respectively. The LED dies 1ar, 1ag, and 1ab are placed in close proximity to each other within LED 1a. The close proximity allows the emitted red, green and blue light from LED dies 1ar, 1ag and 1ab, respectively, to be emitted through the one round output aperture 1aa.

LED 1b shown in FIG. 2 is comprised of three separate LED dies 1br, 1bg and 1bb, and a round aperture 1ba. The LED dies 1br, 1bg, and 1bb are red, green, and blue LED dies that emit red, green, and blue light, respectively. The LED dies 1br, 1bg, and 1bb are placed in close proximity to each other within LED 1b. The close proximity allows the emitted red, green and blue light from LED dies 1br, 1bg and 1bb respectively to be emitted through one round output aperture 1ba.

LED 1c shown in FIG. 2 is comprised of three separate LED dies 1cr, 1cg and 1cb and a round aperture 1ca. LED dies 1cr, 1cg, and 1cb are red, green, and blue LED dies that emit red, green, and blue light, respectively. The LED dies 1cr, 1cg, and 1cb are placed in close proximity to each other within the LED 1c. The close proximity allows the emitted red, green and blue light from the LED dies 1cr, 1cg and 1cb, respectively, to be emitted through one round output aperture 1ca.

When the LED dies 1ar, 1ag, and 1ab of LED 1a are placed in close proximity the red, green and blue light that is emitted by the LED dies 1ar, 1ab and 1ag (respectively) looks substantially blended together to an audience viewer. This provides the audience viewer of a theatrical event with the look of a substantially homogenous color when viewing the combination of light emitted by LED dies 1ar, 1ag and 1ab. For example when the LED dies 1ar, 1ag and 1ab, respectively, emit red, green and blue light, respectively, simultaneously, at an appropriate energy level, the audience viewer views white light emitted by the LED 1a. When red and green light are emitted from LED dies 1ar and 1ag, respectively, and at an appropriate energy level, but no blue light is emitted from LED die 1ab, the audience viewer views yellow light emitted by LED 1a. It is preferred that the red, green and blue LED dies that comprise each of LEDs 1a, 1b, 1c, 2a, 2b, 2c, 3a, 3b,

**3c, 4a, 4b, and 4c** of the multiparameter light **100** of FIG. **1** be mounted in close proximity to each other to cause a substantially homogenous color look to an audience viewer. The controlled emission of the red, green and blue light from the red, green and blue LED dies that comprise each of LEDs **1a, 1b, 1c, 2a, 2b, 2c, 3a, 3b, 3c, 4a, 4b, and 4c** form an additive color mixing system within each of LEDs **1a, 1b, 1c, 2a, 2b, 2c, 3a, 3b, 3c, 4a, 4b, and 4c**. Other colors of LED dies can be used when forming an additive color mixing system such as the color yellow or amber. Alternatively separate LEDs of red, green and blue could be mounted in close proximity to each other to cause a blending of the Red, Green and Blue emitted light, however, in practice it is difficult to locate separate red, green and blue LEDs close enough because of their required packaging.

A commercially available LED with a single output aperture containing red, green and blue LED dies is available from ProLight Opto Technology Corporation (trademarked) of Taiwan, China.

LED emitting circuit boards **20, 30 and 40** of FIG. **1** are constructed similarly to LED emitting circuit boards **10** of FIG. **2**. The LEDs **2a, 2b and 2c** of LED emitting circuit boards **20** of FIG. **1** are constructed similarly to LED emitting circuit boards **10** of FIG. **2**.

The LEDs **3a, 3b and 3c** of LED emitting circuit boards **30** of FIG. **1** are constructed similarly to LED emitting circuit boards **10** of FIG. **2**. The LEDs **4a, 4b and 4c** of LED emitting circuit boards **40** of FIG. **1** are constructed similarly to LED emitting circuit boards **10** of FIG. **2**.

FIG. **3** shows the same LED emitting circuit board **10** of FIG. **2** interconnected by a multi conductor flat cable **330** to an LED signaling circuit board section **310**. The LED signaling circuit board **310** provides controlled output current to the LEDs **1a, 1b, and 1c**. It has been found that the use of a multi conductor flat cable for cable **330** (also referred to as a ribbon cable) is preferred over other types of multiconductor cables because a multi conductor flat cable has a thin cross-section. The thin cross-section allows the multiconductor flat cable **330** to be placed strategically so as not to block any portion of the emitted light from the LEDs **1a, 1b and 1c** and the multiconductor flat cable **330** can be threaded between a small gap in the circuit boards **10, 20, 30 and 40**. This is desirable because the circuit boards **10, 20, 30 and 40** would typically be manufactured of a heat conductive material only allowing the electronics connector **305** of FIG. **3** to be fixed on the same side as the LEDs **1a, 1b, and 1c**. Further the multiconductor flat cable **330** reduces the footprint area of the electronics connector **305** of FIG. **3** allowing for a higher density of LEDs to be placed on the LED emitting circuit board **10**. One such flat cable is manufactured by Molex Electronics (trademarked) of Lisle Ill. The electronics connector **305** is mounted on the LED emitting circuit board **10** and an electronics connector **306** is mounted on the LED signaling board **310**. The connectors **305 and 306** facilitate easy application and removal for service of the multi conductor flat cable **330**. The LED signaling circuit board **310** has an electronic connector **322** for connecting to a data signal that is provided by a logic board **442** shown in FIG. **6** that contains a micro processor **226** and a memory **212**. An additional electronics connector **324**, also shown in FIG. **6**, is used to connect DC voltage power from a DC power supply **221**.

FIG. **4** shows the internal components of the lamp housing **120** of the multiparameter light **100** of FIG. **1**. The LED emitting circuit board **10** is shown with the LEDs **1a, 1b and 1c** fixed thereto. The multiconductor flat cable **330** connects the electronics connector **305** to the electronics connector **306** of the LED signaling board **310**. The LED emitting circuit

board **10** and the remaining three LED emitting circuit boards **20, 30 and 40** (not shown for simplification) are fixed to a heat sink **410** to allow removal of heat generated by the LEDs **1a, 1b, 1c, 2a, 2b, 2c, 3a, 3b, 3c, 4a, 4b, and 4c**. All LED emitting circuit boards **10, 20, 30 and 40** are fixed to the heat sink **410** of FIG. **4** and the heat sink **410** is a component of the lamp housing **120**.

As shown in FIG. **4**, a cooling fan **450** pulls air in the direction of arrows **448a** and **448b** into the lamp housing **120** in the proximity of the heat sink **410** and exhausts the air through the fan **450** in the direction of arrow **452**. For each of the LED emitting circuit boards **10, 20, 30 and 40** of FIG. **1** there is a designated LED signaling board section such as LED signaling board section **310** for LED emitting circuit board **10** of FIG. **4** and there are three additional LED signaling boards (not shown for simplification) that each connect to their own respective LED emitting circuit board of boards **20, 30 and 40**, of FIG. **1** in a similar fashion. As shown in FIG. **6**, the LED signaling board **310** is connected by electronics connector **322** to receive control signals via conductor **440** as supplied by the logic board **442** via electronic connector **422**. All LED signaling boards including signaling board **310** and similar signaling boards (not shown for simplification) have their own connectors similar to connector **322** of LED signaling boards **310** for connection to the logic board **442** so control signals can be received by each LED signaling board and then sent to their respective LED emitting circuit board of **10, 20, 30, and 40** LED signaling circuit boards provide the controlled variable power to their respective LED emitting circuit board of **10, 20, 30, and 40** for powering their respective LEDs with variable power.

The use of LED emitting circuit boards with respective LED signaling circuit boards that can be easily connected or unconnected by a multiconductor flat cable allows a service technician to replace only a set of the plurality of LEDs that comprise the multiparameter light **100** of FIG. **1** or the service technician may only replace a portion of the LED signaling system that drives (or powers) the plurality of LEDs. The use of a plurality of physically disconnected or easily separable circuit boards and LED signaling circuit boards reduces the service cost of replacement components for the multiparameter light **100** of FIG. **1**.

FIG. **5** shows the multiparameter light **100** connected to an external control system that comprises a theatrical control console **550** and a personal computer **530**. The theatrical control console **550** can communicate commands over a theatrical communication network using the DMX protocol created by the United States Institute of Theatre Technology. The DMX protocol, as known in the art, is comprised of 512 control channels with each channel having 256 selectable values. The theatrical control console (or theatrical controller or central controller) **550** is connected via communication line **510** to communication connector **102** of the multiparameter light **100**. The personal computer **530** connects via communication conductor **520** to the communication connector **104** of the multiparameter light **100**. Although communications conductors **510** and **520** are shown, wireless transmission of communications may also be used as known in the art.

The theatrical controller **550** of FIG. **5** has a video screen **552**, an input entry keypad **556**, and input entry devices **554a, 554b, 554c, and 554d**.

The communications between the personal computer **530** and the multiparameter light **100** can be compliant with the Universal Serial Bus (USB) or Ethernet communication schemes. The communications port **211** of FIG. **6** can be compliant with the Universal Serial Bus (USB) or Ethernet communication scheme. The communications port **210** of

FIG. 6 can be compliant with the Electronics Industry Association (EIA) "422" or "485" multipoint communications standard as specified by the DMX protocol.

FIG. 6 shows an internal view of the multiparameter light 100. A first communications port 210 can be compatible with the DMX communications protocol. The theatrical control console 550 is connected to communications port 210 via the communications connector 102 and the communications line 510. A second communications port 104 can be compatible with USB or Ethernet communications schemes. A personal computer 530 is connected to communications port 211 via the communications connector 104 and the communications line 520. The communication ports 210 and 211 are connected to communicate commands, operating software and content received from the theatrical control console 550 and the personal computer 530 to the micro processors 216 and 226. Memory 215 contains the operational software that allows the micro processor 216 of the multiparameter light 100 to respond to commands, content and operational software received by the communication ports 210 or 211. Memory 212 contains the operational software that allows the micro processor 226 of the multiparameter light 100 to respond to commands, content and operational software received by the communication ports 210 or 211. Operational software (OS) is the software that dictates the operational characteristics of multiparameter light 100. The logic circuit board 442 is shown within the lamp housing 120 as a dashed line. The logic circuit board 442 contains the memory 212 and the processor 226. The logic circuit board 442 provides a data signal to the LED signaling circuit board 310 via electronic connectors 422 and 322 and the conductor 440. The logic circuit board 442 is also connected to the further plurality of LED signaling circuit boards (not shown for simplicity via similar electronic connectors and conductors). The LED signaling circuit board 310 is connected to the LED emitting circuit board 10 via the connectors 305 and 306 and the multiconductor flat cable 330. LEDs 1a, 1b and 1c are shown fixed to the LED emitting circuit board 10.

Bearing 112 shown in FIG. 6 and FIG. 1 facilitates the remote controlled panning of the lamp housing 210 in relation to the base housing 110 (motor actuators not shown for simplicity). Mains supply 114 is connected to system power supply 220 and LED power supply 221. LED power supply 221 is connected to the LED signaling circuit board 310 (and the remaining LED signaling boards not shown for simplification) to provide the LED emitting circuit board 10 (and the remaining LED emitting circuit boards not shown for simplification) with controlled power to operate the LEDs 1a, 1b, 1c, 2a, 2b, 2c, 3a, 3b, 3c, 4a, 4b and 4c.

The motor control circuit 218 provides motor control signals to the motor actuators (not shown for simplification) that remotely position the lamp housing 120, and the yoke 115 in relation to the base housing 110 of FIG. 1.

U.S. Pat. No. 6,357,893 to Belliveau, incorporated by reference herein, discloses that a plurality of LEDs of a multiparameter stage light can be individually controlled, where individually controlled refers to on and off as well as intensity. In accordance with one or more embodiments of the present invention, the multiparameter light 100 of FIG. 1 is capable of individually adjusting the intensity of each one of the plurality of LEDs 1a, 1b, 1c, 2a, 2b, 2c, 3a, 3b, 3c, 4a, 4b, and 4c. Furthermore each of the LED dies that make up each of LEDs 1a, 1b, 1c, 2a, 2b, 2c, 3a, 3b, 3c, 4a, 4b, and 4c may have their intensity level (including "on" and "off") individually adjusted by the multiparameter light 100 of FIG. 1 of the present application. Each of the LEDs 1a, 1b, 1c, 2a, 2b, 2c, 3a, 3b, 3c, 4a, 4b and 4c are constructed of multiple LED dies

such as that shown for LED 1a of FIG. 2 wherein the LED dies are shown as 1ar, 1ag and 1ab. The LED dies 1ar, 1ag and 1ab are a red LED die, a green LED die and a blue LED die, respectively, but may be other colored LED dies that comprise each of LEDs 1a, 1b, 1c, 2a, 2b, 2c, 3a, 3b, 3c, 4a, 4b and 4c including a yellow or amber LED die.

Multiparameter light 100 of FIG. 1 is shown constructed of twelve LEDs shown as LEDs 1a, 1b, 1c, 2a, 2b, 2c, 3a, 3b, 3c, 4a, 4b and 4c. Each of the twelve LEDs is similarly constructed of a separate red, green and blue LED die. Each of the thirty-six LED dies is individually controllable as to intensity (including "on" and "off"). The means for multiparameter light 100 there are twelve red light emitting LED dies, twelve green light emitting LED dies and twelve blue light emitting LED dies. The multiparameter light 100 of FIG. 1 may collectively adjust the intensity of all LED dies of one color. For example all twelve red light emitting LED dies may have their light output intensity adjusted (including on and off). All twelve green light emitting LED dies may have their light output intensity adjusted (including on and off). All twelve blue light emitting LED dies may have their light output intensity adjusted (including on and off). When all LED dies of one color are illuminated at the same intensity the multiparameter light 100 looks balanced (since all LED dies of one color are illuminated simultaneously at a particular intensity) to an audience viewer. In this mode the multiparameter light 100 can be used in a conventional way that allows an operator of the theatrical control console 550 to produce red, green and blue color washes.

The multiparameter light 100 of FIG. 1 may also adjust each of the plurality of the thirty-six LED dies (by adjusting each LED die that comprises each LED) to be a different intensity level (including "on" and "off"). In this mode each of the plurality of LEDs 1a, 1b, 1c, 2a, 2b, 2c, 3a, 3b, 3c, 4a, 4b and 4c may be set at different intensity level and a different color (using additive color mixing of the red, green and blue). It is preferred that each LED die such as LED dies 1ar, 1ag and 1ab have their intensity individually controlled with a minimum of two hundred and fifty-eight separate levels of intensity including one of the levels as off and one level as fully on. The fewer the number of intensity levels the easier it is for the audience viewer to see the change from one intensity level to the next intensity level. The more intensity levels the smoother the transition between one adjacent intensity level to the next.

Since the multiparameter light 100 of FIG. 1 may control the 36 LED RGB dies each at a different intensity level (including "on" and "off") it can be seen that over nine thousand intensity levels can be adjusted and in many combinations. An operator of the theatrical control console 550 would find adjustment of the nine thousand intensity levels quite burdensome when trying to create a visual multicolor graphic display from the multiparameter light 100 of FIG. 1. Furthermore many theatrical shows will use a plurality of multiparameter lights, similar or identical to the multiparameter light 100 of FIG. 1 in a system making the work of the operator of the theatrical control console 550 even more burdensome. It has been found by the inventors that pre-storing graphical content within the memory 226 of FIG. 6 simplifies the work of an operator of the theatrical control console 550. The multiparameter light 100 of FIG. 1 may store over one hundred different graphical content programs (GCPs). Each GCP stored in the memory 226 of FIG. 6 is capable of providing intensity information (including "on" and "off") for each of the thirty-six separate LED dies. A GCP may also have several frames of information for each of the thirty-six separate LED dies. Each frame may provide separate intensity infor-

mation (including “on” and “off”) for each of the thirty-six LED dies. One GCP may have 2 or more frames of information used to control each of the thirty-six LED dies. The creation of just one GCP can be time consuming to a person creating the GCP. The inventors of the multiparameter light **100** of FIG. **1** have found that the theatrical control console **550** is not well suited for the creation of GCPs.

The inventors have found that computer graphics formats that have been designed to create graphics on a personal computer provide a greater efficiency when creating a GCP for the multiparameter light **100** of FIG. **1** especially when the GCP contains multiple frames of graphical content. One such graphics format that is preferred to create a GCP for the multiparameter light **100** of FIG. **1** is the Graphics Interchange Format (GIF) that was introduced by CompuServe (trademarked) of Columbus Ohio.

An operator of a personal computer can use a commercially available graphics creation program to create a GIF file for the multiparameter light **100** such as Adobe Flash (trademarked) manufactured by Adobe Systems (trademarked) Incorporated of San Jose Calif. A graphic mask can be created within Adobe Flash (trademarked) that allows a representation of the twelve LEDs **1a, 1b, 1c, 2a, 2b, 2c, 3a, 3b, 3c, 4a, 4b, and 4c** and the intensity level (including “on and “off”) of each red, green and blue LED dies that comprise the LEDs **1a, 1b, 1c, 2a, 2b, 2c, 3a, 3b, 3c, 4a, 4b, and 4c**. Many frames of graphical information that represent the intensity levels of LEDs **1a, 1b, 1c, 2a, 2b, 2c, 3a, 3b, 3c, 4a, 4b, and 4c** and their respective red, green and blue LED dies can be constructed by an operator of the Adobe Flash (trademarked) program to create a GIF file. The many frames of graphical information are used to create a visual animation as the frames are displayed by the LEDs **1a, 1b, 1c, 2a, 2b, 2c, 3a, 3b, 3c, 4a, 4b, and 4c**. The GIF file created by Adobe Flash (trademarked) is stored on a personal computer such as personal computer **530** of FIG. **5**.

In the preferred version a GIF file is used to create a GCP. However other computer graphics formats including but not limited to BMP, JPG and TIF, may be used to create a GCP. It is also possible to use video file formats including but not limited to MPEG and MJPEG to create a GCP.

When using a graphics format file or a video format file to create a GCP, many times the amount of pixel information that is contained in the graphics file is far greater than that required to operate the plurality of LEDs **1a, 1b, 1c, 2a, 2b, 2c, 3a, 3b, 3c, 4a, 4b, and 4c** of multiparameter light **100** of FIG. **1**. Graphics files and video files may contain thousand or even millions of pixels that have their respective intensity and color information contained within. Since the multiparameter light **100** of FIG. **1** only is shown with twelve LEDs **1a, 1b, 1c, 2a, 2b, 2c, 3a, 3b, 3c, 4a, 4b, and 4c** and each LED is made up of a red emitting die, a green emitting die, and a blue emitting die and there are only twelve RBG LEDs to be controlled by the graphics file used to create the GCP. The storage of unnecessary pixel information in a GCP at the memory **212** or memory **215** is therefore a waste of memory space and cost. It has been found to be an advantage for the computer **530** of FIG. **6** to operate a conversion program that strips a graphics file or video file of unnecessary pixel information when creating a GCP. The inventors have envisioned the need to create a computer software program that strips larger graphics or video files created by a graphic creation program of unwanted pixel information and prepares a more efficient GCP. The more efficient GCP created by the conversion computer program then contains a subset of the required data to operate the LEDs thus reducing any unnecessary data that has to be stored in the memory **215** or **212** of FIG. **6**. A commercially available

graphics creation computer program and a conversion computer program that strips the graphics file of unnecessary pixels can both operate on the personal computer **530** of FIG. **6**.

It is also possible to directly store any of a GIF, BMP, JPG, TIF or other graphics format directly in the memory **212** or memory **215** as a GCP. Even video formats such as MPEG or MJPEG or other video file formats can be stored in the memory **212** or the memory **215** of FIG. **6**. However, the storage of graphics formats and video formats without stripping unnecessary pixels that will not be required for the operation of the plurality of LEDs **1a, 1b, 1c, 2a, 2b, 2c, 3a, 3b, 3c, 4a, 4b, and 4c** tends to waste memory space.

The multiparameter light **100** of FIG. **1** can contain hundreds of GCPs in the memory **212** or memory **215**. When the multiparameter light **100** is produced at the factory it is an advantage to produce the product with a plurality of stock factory GCPs (called “stock content”). In this way an operator of the multiparameter light **100** will be able to produce graphic light output from the stock factory GCPs without having to create a custom GCP. One sector of memory in the memory **212** or memory **215** of FIG. **6** is used to store the factory GCPs (stock content). A second sector of memory in the memory **212** or memory **215** is used to store GCPs that have been created by an operator of the multiparameter light **100** of FIG. **1** (called “user content”) if the need should arise.

In practice, an operator of the multiparameter light **100** of the invention can create a desired graphic in a GIF format using a commercially available graphics creation program such as Adobe Flash on the personal computer **530** of FIG. **6**. The personal computer **530** of FIG. **6** can then operate a conversion program to strip the unnecessary pixel information from the created GIF that is not required to operate the LEDs **1a, 1b, 1c, 2a, 2b, 2c, 3a, 3b, 3c, 4a, 4b, and 4c**. The stripped GIF GCP is then ready to be uploaded to the memory **215** or **216** of FIG. **6**. A GCP may be a graphics file that was large and therefore stripped to remove the excess pixel information or a GCP may be the direct graphics file without stripping. The operator then instructs the personal computer **530** to communicate and upload the GCP via communication line **520**, connector **104** and communication port **211**. The processor **216** or **226** receives the uploaded GCP data from the communication port **211** and commits the GCP data to the memory **215** or the memory **212** using operational code stored in the memory **215** or **212**. The GCP data sent by the personal computer **530** of FIG. **6** may be sent compliant with the computer industry communications protocol of the Universal Serial Bus (USB) or Ethernet.

It is also possible for the operator to create a GCP using input devices **554a, 554b, 554c, 554d**, or keypad entry device **556** shown in FIG. **5**, or for an operator to load already created GCP data into the theatrical controller **550** by using a compact disk or other memory storage device. The operator may then input commands using the input devices **554a, 554b, 554c** or **554d** or keypad entry device **556** to transfer the GCP data via communication line **510** and input connector **102** to the communications port **210** of FIG. **6**. The micro processor **216** or **226** using the operational code stored in the memory **215** or **212** respectively transfers the upload data of the GCP sent by the theatrical controller **550** of FIG. **6** to the memory **215** or **212**. The GCP data sent by the theatrical controller **550** of FIG. **6** may be sent compliant with the Electronic Industries Alliance (EIA) “422 or “485” multipoint communications standard as specified by the DMX protocol.

During a theatrical event an operator of the theatrical controller **550** of FIG. **6** may send commands over the communications line **510** that are compliant with the DMX protocol.

The operator of the theatrical controller **550** may input commands by using the input entry devices **554a**, **554b**, **554c** and **554d** or the keypad entry device **556** of FIG. 5. The operator may send a command to pan or tilt the lamp housing **120** of FIG. 1 in relation to the base housing **110**. A pan or tilt command sent by the theatrical controller **550** is received by the communications port **102** and processed by the micro processor **216** using the operational code stored in the memory **215**. The micro processor **216** sends the appropriate control signals to the motor control circuit **218**. The motor control circuit **218** sends the appropriated motor control signals to the pan and tilt motors (not show for simplicity) that can remotely position the lamp housing **120** in relation to the yoke **115** and the lamp housing **120** in relation to the base housing **110**. This allows the operator to remotely position the lamp housing **120** containing the plurality of LEDs in relation to the base housing **110** so as to point the lamp housing **120** at the audience or at an entertainer on the stage if desired. Pointing the lamp housing's LED illuminated graphic display at an audience can provide an exciting graphic visual to the audience. Next the operator of the theatrical controller **550** may command the multiparameter light **100** of FIG. 1 to output graphical light as determined by a first GCP of a plurality of GCPs stored in the memory **212**. The micro processor **226** acts in conjunction with the operational software also stored in the memory **215** or **226** to send control signals derived from the stored GCP data from the logic board **442**. The logic board **442** sends the GCP control signals via conductor **440** through connectors **422** to LED signaling board connector **322** of LED signaling board **310**. The LED signaling board **310** sends power control signals to the LED emitting board **10** via connectors **305** and **306** and flat conductor **330**. The LED emitting board **10** comprises the LEDs **1a**, **1b** and **1c** shown in FIG. 4. The LED emitting board **10** responds by varying the illumination of the LEDs **1a**, **1b** and **1c** as required in response to the GCP. The four LED emitting boards **10**, **20**, **30** and **40** of FIG. 1 each are connected similarly to four respective LED signaling boards (all boards not shown for simplicity). All LED signaling boards are each connected similarly to their respective LED emitting boards in the way that LED signaling board **310** is connected to LED emitting board **10**.

The operator by inputting to the theatrical control console **550** may command the multiparameter light **100** to call up a selected first one of a plurality of GCPs from the memory **215** or **212** of FIG. 6. The operator of the theatrical control console **550** may command the multiparameter light's plurality of LEDs to illuminate in response to the selected first GCP. The selected first GCP may be comprised of a plurality of frames. An audience viewing the multiparameter light **100** of FIG. 1 will visualize multicolored graphical lighting patterns created by the plurality of LEDs that were created by the first GCP stored in the memory of the multiparameter light **100**. Some of the GCPs stored in the memory of the multiparameter light **100** of FIG. 6 are created by the factory (referred to as "stock content") and some of the GCPs are created by an operator using a commercial graphics creation program (referred to as "user content"). The operational code stored in the memory **215** or **212** does not allow the operator to easily edit or change any of the stock content GCPs thus preserving that any multiparameter light similar to identical to **100** operated by the operator will have its stock content preserved.

A GCP can be a single frame of information that dictates how the LEDs **1a**, **1b**, **1c**, **2a**, **2b**, **2c**, **3a**, **3b**, **3c**, **4a**, **4b**, and **4c** are illuminated such as what color (by using additive color mixing of the red, green and blue dies of each LED) and at what intensity (including off and on) for any and each LED. A

GCP can be multiple frames of information used to create a graphical animation as the illumination and colors of the LEDs **1a**, **1b**, **1c**, **2a**, **2b**, **2c**, **3a**, **3b**, **3c**, **4a**, **4b**, and **4c** are varied between frames.

A plurality of GCPs are stored in the memory **215** or **216** of FIG. 6. A first one of the GCPs stored in the memory **215** or **216** can be selected by an operator of the theatrical control console **550** of FIG. 6 by inputting a command by using the appropriate input devices of **554a**, **554b**, **554c** **554d** and or **556**. The command is sent over a communication system which comprises communications line **510**, and the communication connector **102** of the multiparameter light of the invention **100**. The command to evoke the selected GCP is received by the communications port **210** and processed by the microprocessor **226** in conjunction with operational code stored in the memory **212**. Next the processor **226** acting on the operational code extracts the selected first GCP stored in the memory **212** and sends data control signals to the one or more LED signaling circuit boards such as board **310** of FIG. 6. LED signaling circuit board **310** sends the LED power signals to its appropriate LED emitting board **10** via flat cable **330** and flat cable connectors **306** and **305** of FIG. 6. The LEDs of LED emitting board **10** and other LED emitting boards **20**, **30** and **40** may emit the appropriate intensity and color that emulates the first GCP.

As mentioned, a GCP may contain only a single frame or multiple frames of information that can provide intensity and color information to control the emission of the LEDs **1a**, **1b**, **1c**, **2a**, **2b**, **2c**, **3a**, **3b**, **3c**, **4a**, **4b**, and **4c**. FIG. 7 shows the resultant illumination of the LEDs **1a**, **1b**, **1c**, **2a**, **2b**, **2c**, **3a**, **3b**, **3c**, **4a**, **4b**, and **4c** when the multiparameter light **100** responds to a first frame of a first GCP of data stored in the memory **226** of FIG. 6.

#### First GCP, Frame 1

##### LED 1a

**1ar** (red LED die) 50% illumination

**1ag** (green LED die) 0% illumination

**1ab** (blue LED die) 0% illumination

##### LED 1b

**1br** (red LED die) 50% illumination

**1bg** (green LED die) 0% illumination

**1bb** (blue LED die) 0% illumination

##### LED 1c

**1cr** (red LED die) 100% illumination

**1cg** (green LED die) 100% illumination

**1cb** (blue LED die) 0% illumination

##### LED 2a

**2ar** (red LED die) 50% illumination

**2ag** (green LED die) 0% illumination

**2ab** (blue LED die) 0% illumination

##### LED 2b

**2br** (red LED die) 50% illumination

**2bg** (green LED die) 0% illumination

**2bb** (blue LED die) 0% illumination

##### LED 2c

**2cr** (red LED die) 0% illumination

**2cg** (green LED die) 0% illumination

**2cb** (blue LED die) 100% illumination

##### LED 3a

**3ar** (red LED die) 50% illumination

**3ag** (green LED die) 0% illumination

**3ab** (blue LED die) 0% illumination

##### LED 3b

**3br** (red LED die) 50% illumination

**3bg** (green LED die) 0% illumination

**3bb** (blue LED die) 0% illumination

LED 3c  
 3cr (red LED die) 100% illumination  
 3cg (green LED die) 100% illumination  
 3cb (blue LED die) 0% illumination  
 LED 4a  
 4ar (red LED die) 50% illumination  
 4ag (green LED die) 0% illumination  
 4ab (blue LED die) 0% illumination  
 LED 4b  
 4br (red LED die) 50% illumination  
 4bg (green LED die) 0% illumination  
 4bb (blue LED die) 0% illumination  
 LED 4c  
 4cr (red LED die) 0% illumination  
 4cg (green LED die) 0% illumination  
 4cb (blue LED die) 100% illumination

FIG. 8 shows the resultant illumination of the LEDs 1a, 1b, 1c, 2a, 2b, 2c, 3a, 3b, 3c, 4a, 4b, and 4c when the multiparameter light 100 responds to a second frame of data for the first GCP, the second frame of data stored in the memory 226 of FIG. 6.

First GCP, Second frame

LED 1a  
 1ar (red LED die) 0% illumination  
 1ag (green LED die) 75% illumination  
 1ab (blue LED die) 0% illumination  
 LED 1b  
 1br (red LED die) 0% illumination  
 1bg (green LED die) 75% illumination  
 1bb (blue LED die) 0% illumination  
 LED 1c  
 1cr (red LED die) 0% illumination  
 1cg (green LED die) 100% illumination  
 1cb (blue LED die) 0% illumination  
 LED 2a  
 2ar (red LED die) 0% illumination  
 2ag (green LED die) 75% illumination  
 2ab (blue LED die) 0% illumination  
 LED 2b  
 2br (red LED die) 0% illumination  
 2bg (green LED die) 75% illumination  
 2bb (blue LED die) 0% illumination  
 LED 2c  
 2cr (red LED die) 100% illumination  
 2cg (green LED die) 0% illumination  
 2cb (blue LED die) 100% illumination  
 LED 3a  
 3ar (red LED die) 0% illumination  
 3ag (green LED die) 75% illumination  
 3ab (blue LED die) 0% illumination  
 LED 3b  
 3br (red LED die) 0% illumination  
 3bg (green LED die) 75% illumination  
 3bb (blue LED die) 0% illumination  
 LED 3c  
 3cr (red LED die) 0% illumination  
 3cg (green LED die) 100% illumination  
 3cb (blue LED die) 0% illumination  
 LED 4a  
 4ar (red LED die) 0% illumination  
 4ag (green LED die) 75% illumination  
 4ab (blue LED die) 0% illumination  
 LED 4b  
 4br (red LED die) 0% illumination  
 4bg (green LED die) 75% illumination  
 4bb (blue LED die) 0% illumination

LED 4c  
 4cr (red LED die) 100% illumination  
 4cg (green LED die) 0% illumination  
 4cb (blue LED die) 100% illumination

5 Although FIG. 7 and FIG. 8 show the resultant illumination of two frames of illumination for a first GCP many GCPs may contain more than two frames of data that can provide a colored animation of the projected light emitted by LEDs 1a, 1b, 1c, 2a, 2b, 2c, 3a, 3b, 3c, 4a, 4b, and 4c from the multiparameter light 100 of FIG. 1.

10 The “stock content” and the “user content” stored in the memory 212 of the multiparameter light 100 can be individually accessed and evoked by the operator of the theatrical control system 550 of FIG. 6. A first command initiated by the operator of the theatrical control system 550 by using any of the appropriate input devices 554a, 554b, 554c, 554d and 556 can select to evoke one of a plurality of stock content GCPs. A second command initiated by the operator of the theatrical control system 550 by using any of the appropriate input devices 554a, 554b, 554c, 554d and 556 can select to evoke one of a plurality of user content GCPs. The theatrical control system 550 of FIG. 6 may communicate commands to the multiparameter light 100 of FIG. 1. A first designated DMX channel may provide a selection of up to 256 “stock content” GCPs. A second designated DMX channel may provide selection of up to 256 “user content” channels. It is preferred that the stock content and the user content each utilize a separate DMX channel.

15 An operator of the theatrical controller 550 of FIG. 5 can use the first designated DMX channel to call up a first animated GCP. The GCP can be an animated GCP that is comprised of a plurality of frames that make up the animation. The frames of a GCP that are used to present an animation are stored in the memory 212. The memory 212 passes the stored frame information of the first animated GCP to the processor 226 that in turn passes each animation frame sequentially to the LED signaling boards such as LED signaling board 310. The LED signaling boards such as LED signaling board 310 provides controlled variable power to their respective LED emitting circuit boards such as LED emitting circuit boards 10, 20, 30, and 40 of FIG. 1 for powering their respective LEDs with variable power to visually create the animation on a frame by frame basis.

20 The controlled selecting of one animated GCP to another animated GCP by the operator of the theatrical controller 550 when adjusting the first DMX channel results in generating a pleasing light display by the multiparameter light 100. It has been found however that an improvement to the interaction between the music or events on the stage can further be had by allowing the operator of the theatrical controller 550 to individually select a frame of an animated GCP by varying an input device such as input device 554a, 554b, 554c or 554d of the theatrical controller 550. The input devices 554a, 554b, 554c and 554d can be rotary input devices such as rotary optical encoders or it is preferred that the input devices 554a, 554b, 554c and 554d be sliding potentiometers or linear encoders. The varying of the input device such as input device 554a causes the DMX values of a second DMX channel to be varied and sent from the theatrical controller 550 and received at the communications port 210 of the multiparameter light 100. The use of a sliding potentiometer for input device 554a allows the operator of the theatrical controller 550 to quickly use the hand to go from one frame to another frame of a plurality of frames of a selected GCP live and in fast response to music or other actions on the stage. The selected GCP animation by way of example may be an animation of lips that open and close and use eight frames to create the animation.

15

The operator using an input device of the theatrical controller **550** such as input device **554a** can open and close the lips by selecting which one of the eight frames of the selected animation are to be displayed by the multiparameter light **100** in response to music or other actions on the stage during a performance. 5

Because a DMX channel under the DMX protocol is equipped with 256 discrete values it has been found that scaling the frames of a GCP to the 256 discrete DMX values of the second DMX channel produces the best result for live control of the frames of an animated GCP. The scaling of any selected GCP to the 256 discrete DMX values of the second DMX channel transmitted by the theatrical controller **550** and received by the multiparameter light **100** is accomplished by the operating software stored in the memory **215** or **212** of the multiparameter light **100**. A GCP may only have one frame and thus not be animated or a GCP may have hundreds of frames. FIG. **9A** shows a second GCP having two frames of animation that has been scaled to the second DMX control channel having two hundred and fifty-six values (0-255). Frame one of the second GCP is scaled to DMX values 0 through 126. Frame two of the second GCP is scaled to DMX values 127 through 255. In this way an input device such as input device **554a** of theatrical controller **550** that is an input slider operating to select DMX values 0-255 of the second DMX channel can select frame one of the second GCP when the input slider **554a** is located in any position that causes a DMX value of 0 through 126. A sliding input device is known in the art and an example of a sliding input device is manufactured by Alps Electronic Co. (trademarked) LTD. of Tokyo, Japan. Slider input device **554a** when positioned to produce DMX values 127 through 255 causes the selection of frame **2** of the second GCP. Scaling the second GCP to the second DMX channel values can be referred to as substantially scaling the frames of the second GCP in relation to the range of the second DMX channel values. This means that the majority of the DMX channel range is associated with frames of the GCP. In this way as the full or majority range of the physical movement of input device **554a** required to scan from 0 to 255 DMX values can cause all or the majority of the frames of the GCP to be referenced. 40

FIG. **9B** shows a third GCP with eight frames of animation. Again the DMX channel under the standard has two hundred and fifty-six discrete values. The third GCP has its eight frames mapped by the operating system stored in the memory **215** or **212** of FIG. **6** by scaling the eight frames of the third GCP to the DMX channels two hundred and fifty-six discrete values. 45

We claim:

**1.** A stage lighting apparatus comprising:

a communications port;

a processor;

a memory;

a lamp housing;

a base housing; and

a plurality of light emitting diodes including a first light emitting diode including a first color, a second light emitting diode including a second color, and a third light emitting diode including a third color, wherein the first color, the second color and the third color are different from each other; 60

wherein the lamp housing is remotely positionable in relation to the base housing;

wherein a plurality of graphical content programs, each comprised of a plurality of frames of data, are stored in the memory; and 65

16

wherein the processor is programmed to select a first frame of data of a plurality of frames of data of a first graphical content program of the plurality of graphical content programs if a first DMX value supplied by an operator of a theatrical control system on a first DMX channel is within a first range of DMX values, and the processor is programmed to use the first frame of data to cause:

the first light emitting diode to be illuminated to a first percent illumination;

the second light emitting diode to be illuminated to a second percent illumination; and

the third light emitting diode to be illuminated to a third percent illumination;

wherein the first percent illumination, the second percent illumination, and the third percent illumination are different from each other; and

wherein the processor is programmed to select a second frame of data of the plurality of frames of data of the first graphical content program of the plurality of graphical content programs if the first DMX value supplied by the operator of the theatrical control system on the first DMX channel is within a second range of DMX values, wherein the first range is different from the second range, the second frame of data is different from the first frame of data, and the processor is programmed to use the second frame of data to cause:

the first LED to be illuminated to a fourth percent illumination;

the second LED to be illuminated to a fifth percent illumination; and

a third light emitting diode to be illuminated to a sixth percent illumination; and

wherein the fourth percent illumination, the fifth percent illumination, and the sixth percent illumination are different from each other.

**2.** The stage lighting apparatus of claim **1** wherein the first range of DMX values and the second range of DMX values together make up all the possible DMX values for the first DMX channel.

**3.** The stage lighting apparatus of claim **2** wherein there is no overlap between the first range of DMX values and the second range of DMX values.

**4.** The stage lighting apparatus of claim **1** wherein the first DMX value is supplied by the operator by use of an input device.

**5.** The stage lighting apparatus of claim **4** wherein the input device is a slider.

**6.** A method of operating a stage lighting apparatus comprising:

remotely positioning a lamp housing of the stage lighting apparatus in relation to a base housing of the stage lighting apparatus, wherein the lamp housing includes therein a plurality of light emitting diodes, which include a first light emitting diode including a first color, a second light emitting diode including a second color, and a third light emitting diode including a third color, wherein the first color, the second color, and the third color are different; 55

storing a plurality of graphical content programs in a memory of the stage lighting apparatus;

receiving at a processor, a first DMX value on a first DMX channel from an operator of a theatrical control system; using the processor to determine if the first DMX value is within a first range of DMX values;

if the first DMX value is within the first range of DMX values, using the processor to select a first frame of data of a plurality of frames of data of a first graphical content

17

program of the plurality of graphical content programs in memory, and if the first DMX value is within the first range of DMX values, using the first frame of data to cause:

the first light emitting diode to be illuminated to a first percent illumination; 5

the second light emitting diode to be illuminated to a second percent illumination; and

the third light emitting diode to be illuminated to a third percent illumination; 10

wherein the first percent illumination, the second percent illumination, and the third percent illumination are different from each other; and

further comprising 15

using the processor to determine if the first DMX value is within a second range of DMX values;

if the first DMX value is within the second range of DMX values, using the processor to select a second frame of data of the plurality of frames of data of the first graphical content program of the plurality of graphical content programs, wherein the first range is different from the second range, the second frame of data is different from the first frame of data, and further comprising 20

18

if the first DMX value is within the second range of DMX values using the second frame of data to cause:

the first light emitting diode to be illuminated to a fourth percent illumination;

the second light emitting diode to be illuminated to a fifth percent illumination; and

a third light emitting diode to be illuminated to a sixth percent illumination; and

wherein the fourth percent illumination, the fifth percent illumination, and the sixth percent illumination are different from each other.

7. The method of claim 6 wherein the first range of DMX values and the second range of DMX values together make up all the possible DMX values for the first DMX channel.

8. The method of claim 7 wherein there is no overlap between the first range of DMX values and the second range of DMX values.

9. The method of claim 6 wherein the first DMX value is received from an input device.

10. The method of claim 9 wherein the input device is a slider.

\* \* \* \* \*