



US008056275B2

(12) **United States Patent**
Ballew

(10) **Patent No.:** **US 8,056,275 B2**
(45) **Date of Patent:** **Nov. 15, 2011**

(54) **WATERLESS SYSTEM FOR PROVIDING FAN-SHAPED FOUNTAIN EFFECT**

(75) Inventor: **Charles Summers Ballew**, Burbank, CA (US)

(73) Assignee: **Disney Enterprises, Inc.**, Burbank, CA (US)

(*) Notice: Subject to any disclaimer, the term of this patent is extended or adjusted under 35 U.S.C. 154(b) by 56 days.

(21) Appl. No.: **12/542,807**

(22) Filed: **Aug. 18, 2009**

(65) **Prior Publication Data**

US 2011/0045227 A1 Feb. 24, 2011

(51) **Int. Cl.**
G09B 11/00 (2006.01)

(52) **U.S. Cl.** **40/435; 40/431**

(58) **Field of Classification Search** **40/427-433; 362/253, 644**

See application file for complete search history.

(56) **References Cited**

U.S. PATENT DOCUMENTS

1,445,977	A *	2/1923	Shepard	40/433
2,147,232	A *	2/1939	Ballew	40/433
2,513,100	A *	6/1950	Jens	40/435
2,795,065	A *	6/1957	Jean et al.	40/435
2,798,324	A *	7/1957	Berger et al.	40/435

2,811,798	A *	11/1957	Brooks	40/431
2,857,507	A *	10/1958	Stec	40/432
3,030,944	A *	4/1962	Blau	600/558
3,142,919	A *	8/1964	Richardson	40/421
3,900,978	A *	8/1975	Sloan	40/435
5,672,057	A *	9/1997	Engel	434/84
6,513,951	B1 *	2/2003	Wang et al.	362/253
6,592,423	B1 *	7/2003	Boyle et al.	446/175
7,056,006	B2 *	6/2006	Smith	362/644

* cited by examiner

Primary Examiner — Joanne Silbermann

Assistant Examiner — Shin Kim

(74) *Attorney, Agent, or Firm* — Marsh Fischmann & Breyfogle LLP; Kent A. Lembke

(57) **ABSTRACT**

An apparatus for creating a water disk effect without water. The apparatus includes first and second disks, each having a first side with a substantially planar surface and a second side with a surface textured with a three dimensional (3D) pattern or topography including raised, arcuate ridges in a whirlpool or spiral arrangement. The apparatus includes a housing that supports the first and second disks for independent rotation about a common axis. The disks are positioned such that the first sides are proximate but spaced apart to avoid contact, such that the 3D patterns face outward toward viewers of the apparatus. The apparatus includes a drive assembly rotating the first disk in a first direction and concurrently rotating the second disk in a second direction opposite the first direction. A water disk effect is created during counter rotation when light from the Sun or other source strikes the disks.

19 Claims, 7 Drawing Sheets

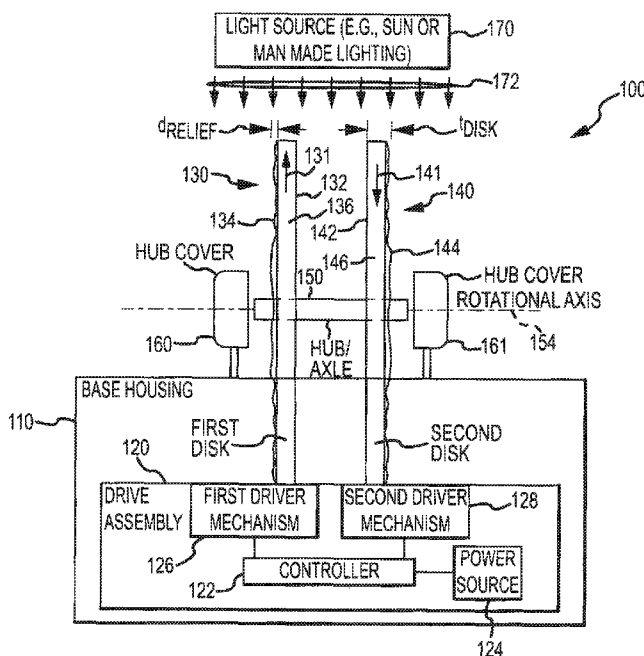

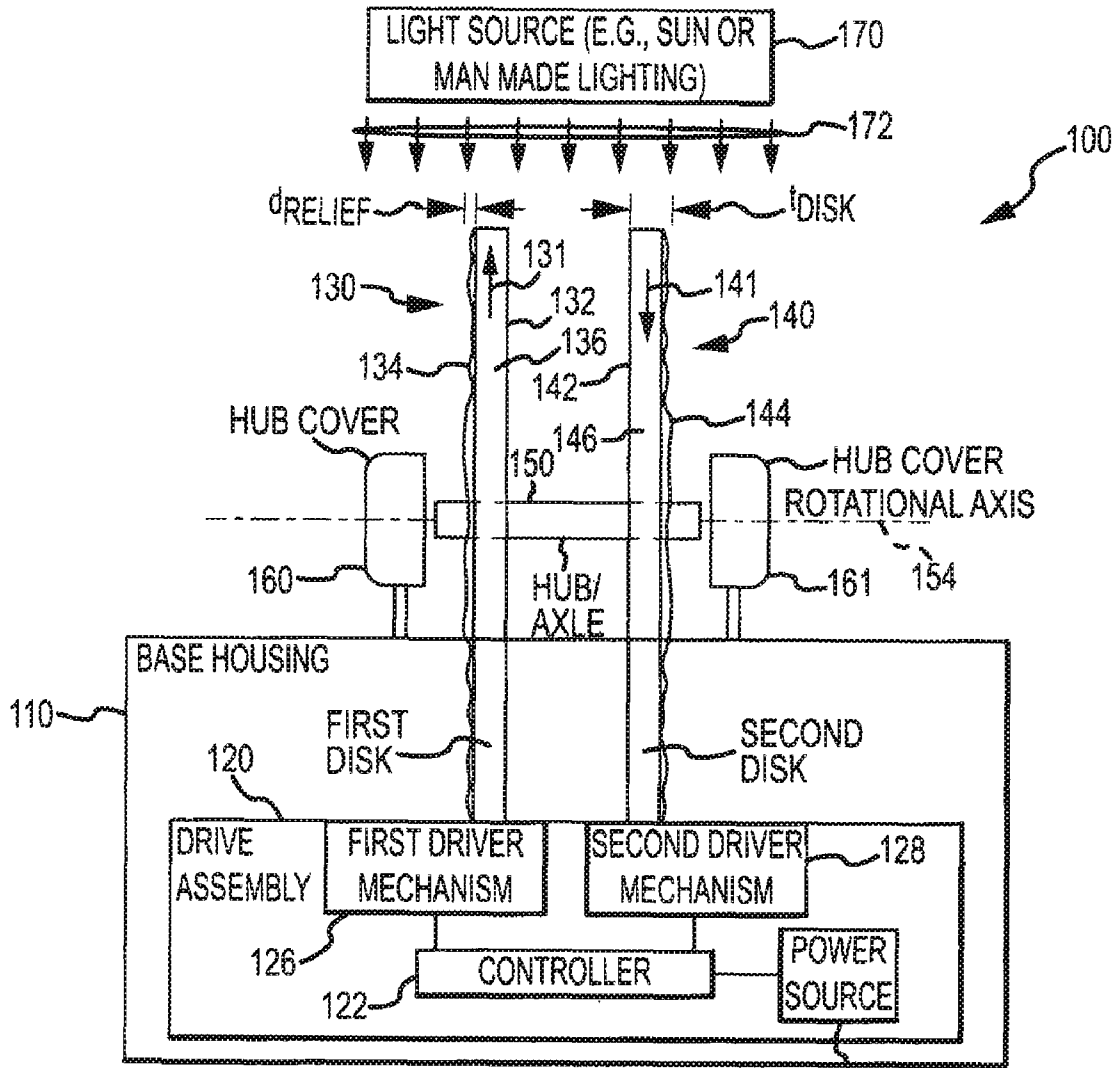

FIG. 1

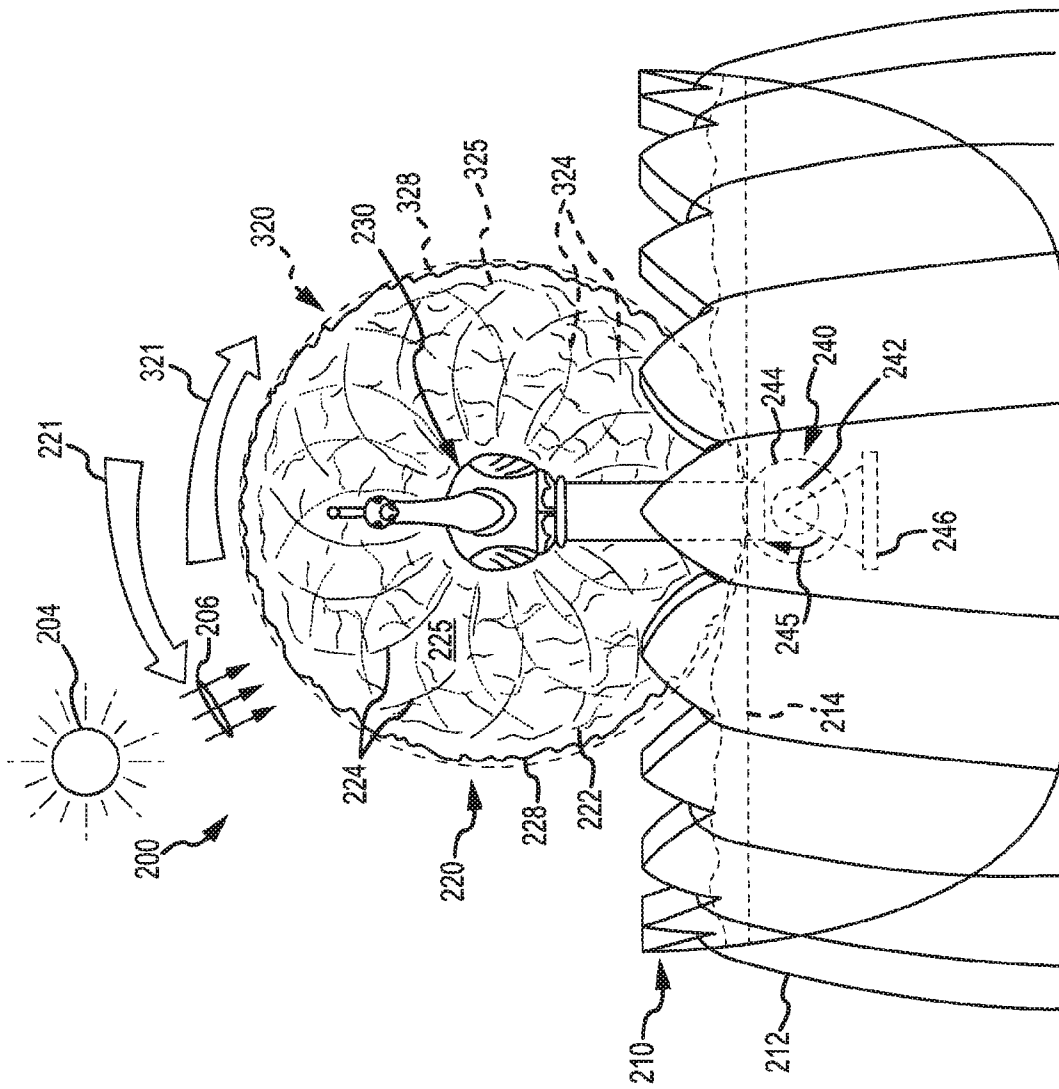

FIG.2

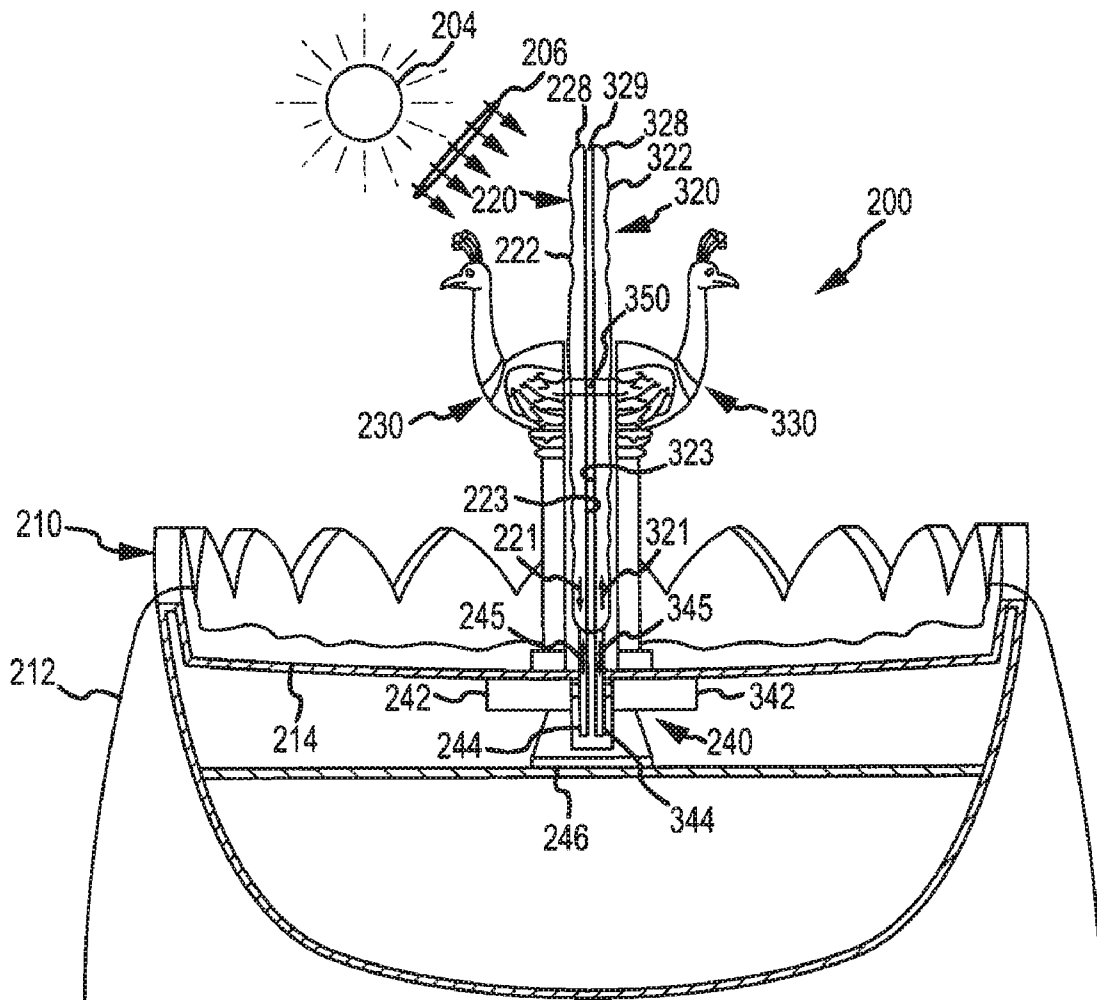

FIG. 3

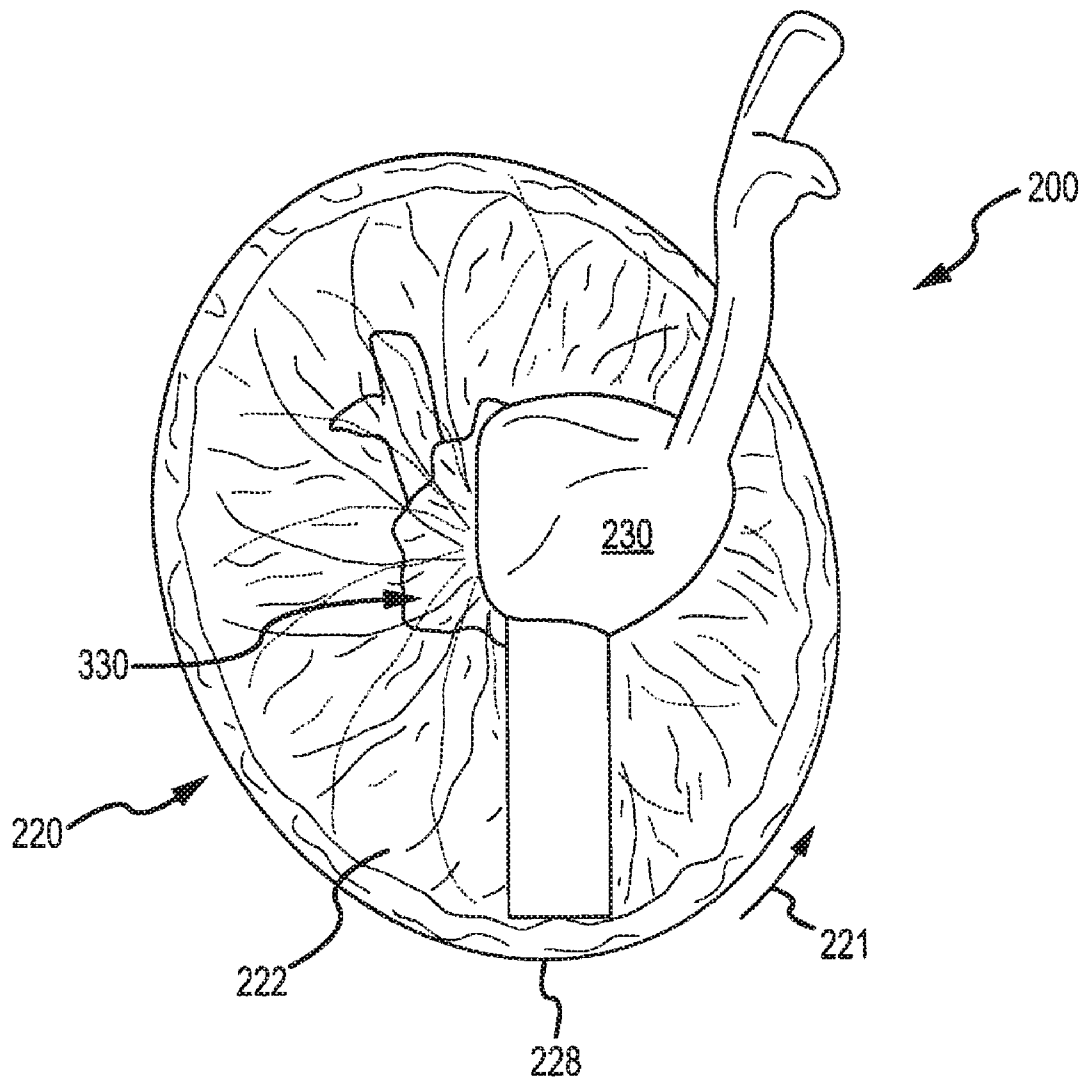

FIG. 4

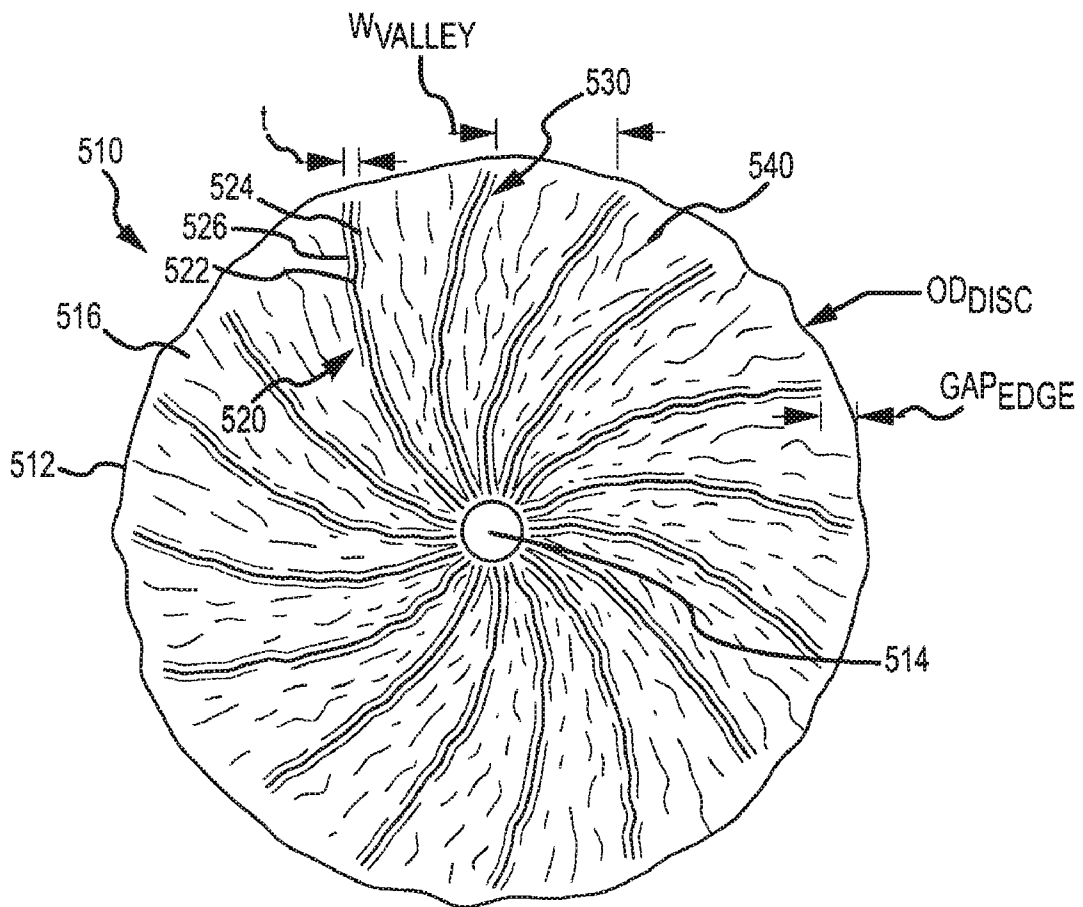

FIG.5

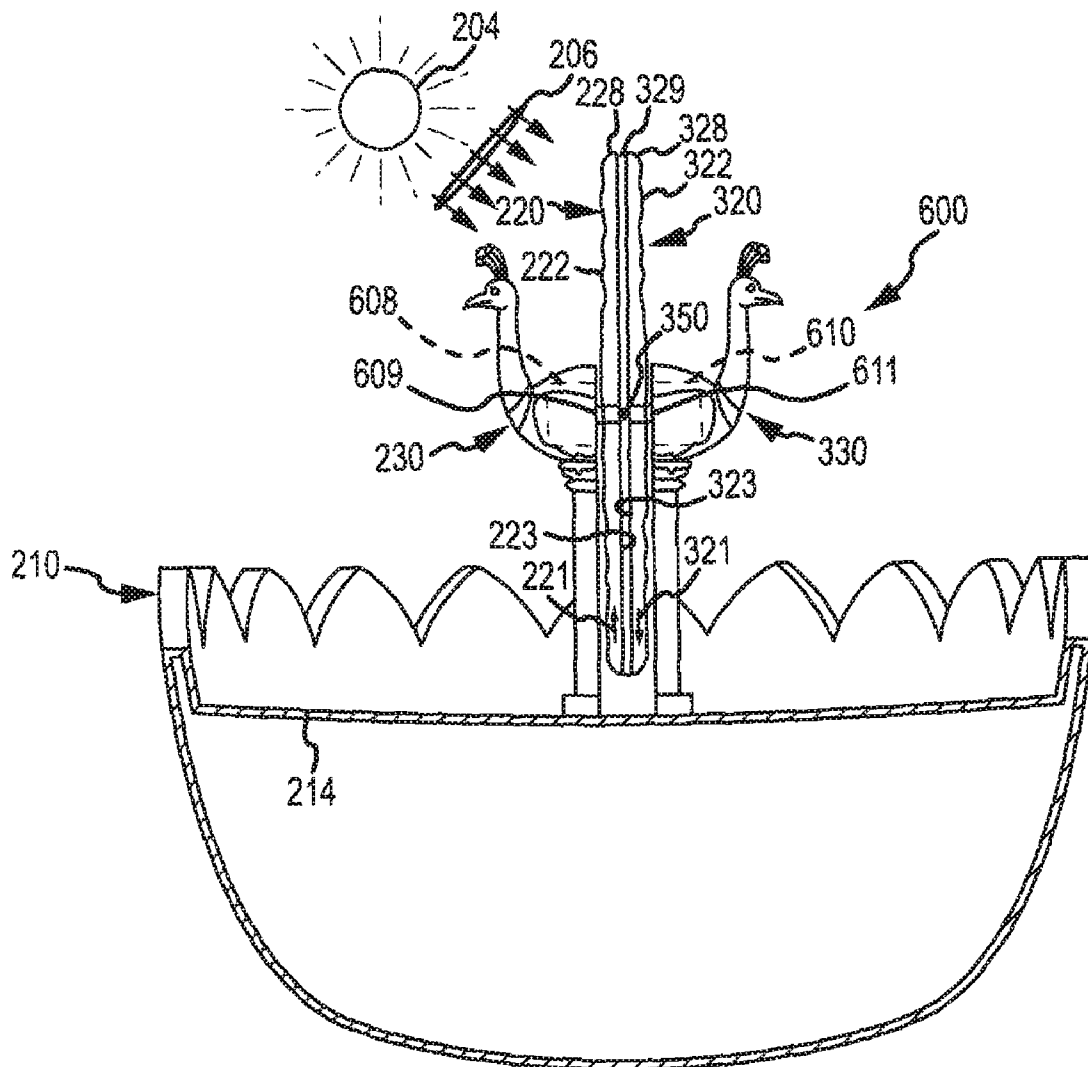

FIG.6

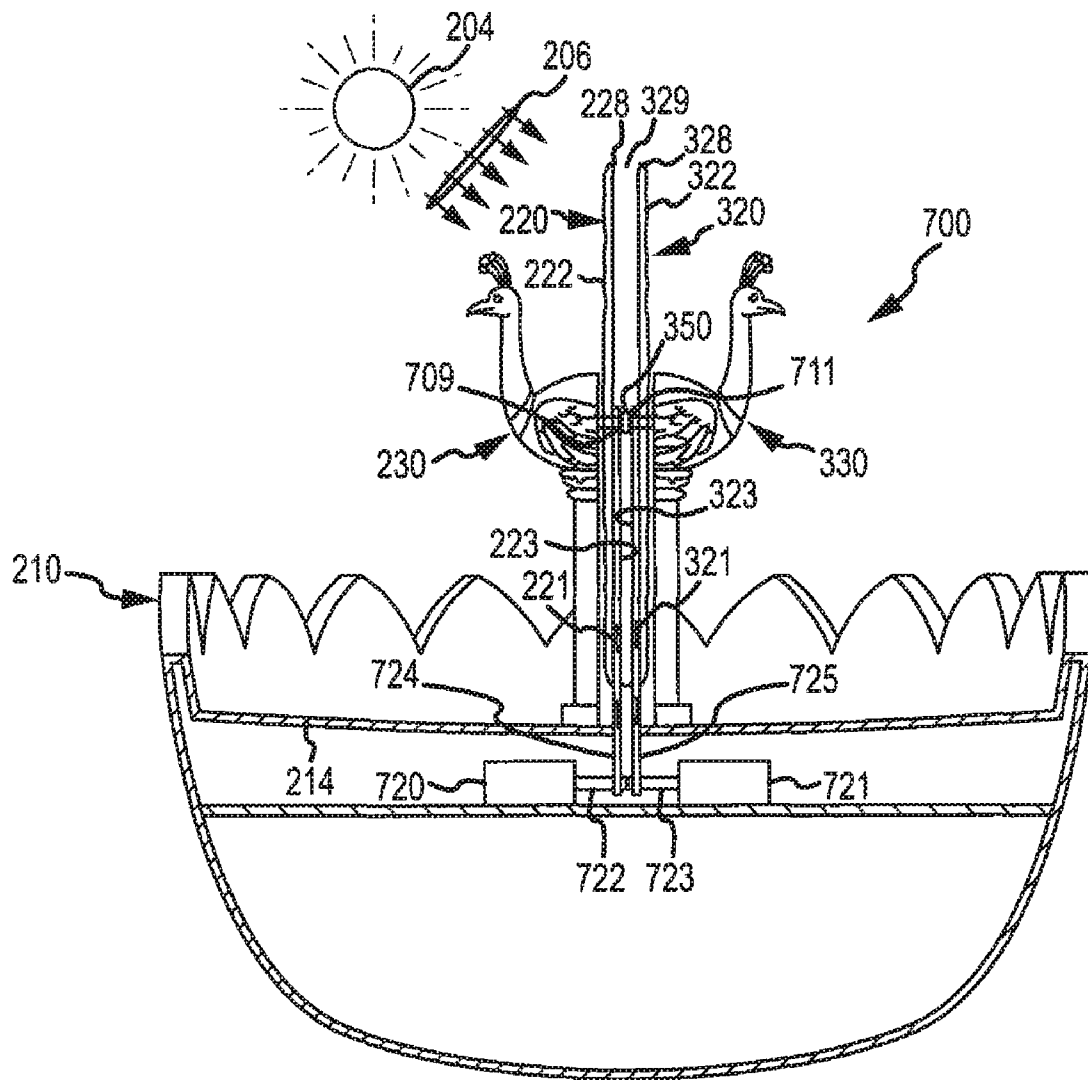

FIG. 7

WATERLESS SYSTEM FOR PROVIDING FAN-SHAPED FOUNTAIN EFFECT

BACKGROUND OF THE INVENTION

1. Field of the Invention

The present invention relates, in general, to water displays or fountains, optical illusion systems, and special effect devices, and, more particularly, to an apparatus or system for achieving an illusion of a fan-shaped, liquid fountain in a dry or waterless manner.

2. Relevant Background

In many settings, it is desirable to provide a pleasing visual display to enhance a visitor's experience of a park, an entertainment facility, a public building, and so on. Water displays aid fountains are often used to create effects with water and lights may be accompanied by music to create a crowd-pleasing effect. Water displays are becoming increasingly sophisticated and complicated in design and operation with most water displays including a body of water such as pool or lake and numerous remotely-controlled nozzles and/or water display devices. The water display devices are often computer controlled to spray or disperse water in a timed or synchronized pattern. Presently-available water display systems have produced useful water displays and shows, but there have been many barriers toward their more widespread adoption and use.

Existing water display devices are typically submerged in a body of water and may be fixed in place or provided on a movable platform. The movable platform is typically raised and lowered by other submerged components to bring the nozzle or water outlet above the surface of the water during the show, and the movable platform is often quite large. Another problem facing water display designers is how to provide a moving head or nozzle system that can articulate to numerous positions. Such a range of nozzle or water outlet positions is desirable for providing displays and shows with greater variety and allows designers to play with the water to create different looks utilizing fewer fountains or water display devices (and, hence, fewer platforms that have to be raised and lowered in the water). Another problem with existing water display systems is alignment of the outlet or nozzle prior to beginning a show or display sequence. With existing fountains and water displays, the alignment process is very labor intensive and inaccurate as workers generally enter the pond or body of water and try to set the nozzle to a home position by hand. Often, this simply involves "eyeballing" the position of the nozzle to reset it into a desired position while standing in water. Such aligning is then repeated periodically as the equipment may tend to become unaligned with use in shows.

In other settings, it may be desirable to provide a fountain in conjunction with moving parts such as within a ride. In other words, the fountain itself may not have moving parts but the nearby portions of a physical support may have moving components such as if the fountain is positioned on top or within an amusement park ride (e.g., a rotating ride structure). In such applications, it may be very difficult and expensive to create a rotary union that allows water to be piped to the fountain without leaking and significant wear and maintenance requirements.

In addition to these challenges presented by fountains and water displays, there are many applications where it is useful to create an effect such as a fan of water, but the use of water may not be desirable or even possible. For example, it may be useful to provide a fan of water within or near an amusement park ride or near the entrance of a building, but the use of

water would require plumbing and cause maintenance problems such as to repair leaks and to realign fountain heads. Further, the spray of water may be difficult to control due to wind effects. Still further, it may be undesirable to have water contact nearby structures or equipment as this may cause discoloring of nearby buildings and walls or may detrimentally effect ride or other operating mechanisms (e.g., increase corrosion of mechanical components, require additional lubrication or enclosure components to minimize exposure to moisture). Also, use of water fountains may result in viewers and others nearby getting wet from spray or blown water, when this is not desired or planned.

SUMMARY OF THE INVENTION

The present invention addresses the above problems by providing an assembly or system adapted for providing a water disk effect or optical illusion without requiring use of water (e.g., in a "dry" manner). The assembly includes two counter rotating disks or plates that have a shared or common rotation axis (e.g., one disk rotates clockwise while the other concurrently rotates counterclockwise). Each disk is formed of a material(s) such that it is at least translucent to light such as a plastic, glass, ceramic, or the like that may have an index of refraction similar to that of water. In one case, the index of refraction (and coloring) is selected to match that of water with an index of refraction within about 20 percent of the index of refraction of water while another application calls for an index of refraction for each disk that is at least about 1.3.

The disks may have a similar configuration (or nearly identical configuration as may occur if made from a single mold) with one side or the inner surface being planar. The two disks are arranged in the assembly such that the two planar or inner surfaces are proximate to each other and parallel, but they are spaced apart to support frictionless counter rotation of the paired disks. The second side or outer surface of each of the disks is nonplanar or textured with a pattern including a number or set of side-by-side, raised or protruding ridges, ribs, or refractive elements. The ridges are arcuate or bowed and are arranged in a pattern, which may provide a series of spaced apart walls or jets of water-like features or more typically may provide an illusion of a circular or fan-shaped spray of water. The ridges may be somewhat irregular so as to simulate a more random, natural look of water, and the ridges may spiral loosely toward the center of the disk.

When the disks are rotated and light passes through the disks (e.g., ambient light such as from the Sun or another source), the ridges on both disks distort the light in a similar manner as a fan shaped spray of water. The ridges are "parallel" with similar amounts of curvature or bowing (e.g., with similar defining radii) to provide a repeating pattern and the outward portion of the bend or curve is generally in the same direction on each disk to provide a whirlpool or partial spiral pattern of radial "flowing" water as the disk is rotated. Rotation of each disk is typically in the direction of the bend or bowing of the ridge elements, e.g., if bend is to the left, when viewed along the rotation axis, then the rotation is counterclockwise while if the bend is to the right the rotation may be clockwise. The interference of light being refracted by adjacent or proximate pairs of the ridge elements on the two disks fools or distracts a viewer's eyes such that they see radial, outward movement, and the refraction of light similar to that provided by water makes the movement appear to be flowing water.

More particularly, an apparatus is provided for creating a "dry" water disk effect. The apparatus includes first and second disks, with each disk having a first side with a substan-

tially planar or flat surface (e.g., the inner surfaces of the disk pair) and a second side with a surface textured with a three dimensional pattern or topography (e.g., the outer or outward facing surfaces of the disk pair). The apparatus includes a housing that supports the first and second disks such that they can independently rotate about a common axis that extends generally through the centers of the disks. The disks are positioned in the apparatus such that the first sides with the planar surfaces are proximate to each other but spaced apart to avoid contact, such that the 3D patterns face outward or are visible to viewers of the apparatus. The apparatus also includes a drive assembly that is adapted to rotate the first disk in a first direction about the rotation axis and to concurrently rotate the second disk in a second direction about the rotation axis, with the first and second directions being opposite (such as clockwise and counterclockwise or vice versa). A water disk effect is created during such counter rotation whenever light strikes the disks such as when sunlight is incident on the apparatus.

The 3D pattern may include a number of arcuate or bowed ridges extending generally from a center of the disks toward an outer edge (which may also be textured such as with a serrated appearance or profile). Each of the arcuate, raised ridges may be curved or bowed in a common direction on each disk relative to the centers of the disk, and rotation of each disk may be in the direction of the bow or curve (e.g., from a center of curvature toward the curved ridgeline or the like). The common direction of the curve may coincide with the rotation directions for each of the two disks. The 3D pattern may also include an irregular textured surface within the gap or valley between adjacent pairs of the ridges or arcuate elements. The arcuate ridges may have a relief or height relative to the disk body that is at least about 25 percent of the thickness of the disk (e.g., about 0.5 inches when the disk is 2 inches thick and so on).

The disks may be made of a material or have a composition of material to cause each disk to have an index of refraction of at least about 1.3 (e.g., formed from a water clear urethane resin or the like). The drive assembly may include first and second drive mechanisms mechanically linked to the first and second disks, respectively, for driving the disks at rotation rates in the range of about 20 to about 30 revolutions per minute (RPMs) with some embodiments having the two rotation rates being substantially equal such as within 3 RPMs of each other. The housing may include an enclosure assembly that covers or hides from view an axle or hub member supporting the two disks proximate to the centers of the disks, and the disks may be supported so as to extend into the housing (or behind other view-hiding components/structure) such that at least about one fourth of each disk is hidden from view so as to cause a viewer to more readily believe water is used to create a fan-shaped spray of water effect or illusion and that the water is returned by gravity to the housing (e.g., the full disk shape or body is hidden from viewers).

BRIEF DESCRIPTION OF THE DRAWINGS

FIG. 1 illustrates in functional block form a water disk effect assembly of an embodiment described herein;

FIG. 2 is a front view of one embodiment of a water disk effect assembly (such as a practical implementation of the assembly shown in FIG. 1);

FIG. 3 is a side or edge view of the assembly of FIG. 2 showing the counter-rotating, spaced apart disks used to create a fountain/water effect in a dry or waterless manner;

FIG. 4 is a perspective view of the assembly of FIGS. 2 and 3 with the base assembly removed showing the achieved water disk effect;

FIG. 5 illustrates a plan view of a disk showing the textured or outer side of the disk showing one useful pattern of raised or protruding, arcuate ridges arranged about a center hole (for receiving a rotational axle or hub) in a spiral or whirlpool pattern and including a textured surface between adjacent ridges (e.g., in some embodiments, the valley between each pair of adjacent ridges or ribs may be contoured or have an irregular 3D topology rather than simply being smooth or planar);

FIG. 6 illustrates a water disk effect assembly similar to that shown in FIGS. 2-4 showing use of an alternative drive assembly to provide opposing or counter rotation of the two textured/patterned disks; and

FIG. 7 illustrates another water disk effect assembly similar to that shown in FIGS. 2-4 and 6 showing use of another drive assembly using belts to provide counter rotation of the pair of disks.

DETAILED DESCRIPTION OF THE PREFERRED EMBODIMENTS

Briefly, embodiments of the present invention are directed to an assembly that produces an appearance of a water disk as may be produced with a fountain but without the use of any water. Hence, the assembly may be considered a “dry” water disk effect assembly in which no plumbing is required and no concerns of damage or problems associated with spraying water to produce a fan or circular wall. The dry fan or disk effect provided is unaffected by winds that would disrupt a water-based fountain of such shape, and the water is not blown onto viewers or passersby that may wish to stay dry.

FIG. 1 illustrates a functional block drawing of a water disk effect assembly or system 100 of one embodiment of the invention. As shown, the assembly 100 includes a base housing 110 that supports a drive assembly 120 as well as a pair of hub covers/supports 160, 161. The drive assembly 120 may take many forms and generally, as is described in detail herein, functions to drive two disks 130, 140 in opposite directions or to counter rotate the disks (e.g., one is rotated clockwise while the other is rotated counterclockwise). The drive assembly 120 may include a first driver mechanism 126 and a second driver mechanism 128 to provide such separate and differing rotation of the two disks 130, 140.

The drive mechanisms 126, 128 may be run and/or powered by a controller 122 and power source 124 to rotate the disks 130, 140 as shown at 131, 141 about the hub or axle 150 at desired rotation rates (e.g., 10 to 40 revolutions per minute (RPM) or, in some cases, in the range of 20 to 30 RPMs). In some cases, the controller 122 may be remotely operable to operate the driver mechanisms 126, 128 at one speed or at a number of speeds or may operate in a continuous manner when power is supplied via source 124 such as to rotate the disks 130, 140 at a desired rotation rate to achieve a desired water disk effect (with the speed often being adjusted/tuned to suit a particular disk design (or surface pattern/topography) and other parameters such as lighting levels, material used for the disk bodies, and the like).

Significantly, the assembly 100 includes a pair of disks 130, 140 that are supported by the hub covers 160, 161 on the hub/axle 150, which may extend through a centrally located hole in the disk bodies. The disks 130, 140 typically will extend part way into the housing 110 such that a lower portion of the disks 130, 140 is obscured or hidden from view, whereby viewers are led to believe the “water” is falling down

back into the housing. In some embodiments, up to two thirds of the disks **130, 140** extend into the housing **110** whereas in other embodiments at least one fourth of the disks **130, 140** extend into the housing **110** to enhance the fountain or water fan effect. In some embodiments, the disks **130, 140** also extend into the housing **110** such that an edge **136, 146** of each disk **130, 140** contacts a portion of the drive mechanisms **126, 128** such that the driver mechanisms **126, 128** can impart the rotations **131, 141** (such as by using a wheel, belt, gear, or the like that abuts the edge **136, 146**). In this manner, the driving of the disks **130, 140** is also hidden from view as is the support at hub **150** by hub covers **160, 161**. As shown, each of the disks **130, 140** rotates about a common rotation axis **154** that may extend through the center of the hub **150** and the disks **130, 140**, and, in most embodiments, the disks **130, 140** each have an equal or substantially equal outer diameter such that a viewer of the assembly along the rotation axis **154** may not see a hidden or rear one of the disks **130, 140**.

The effect provided by assembly **100** is achieved in part by providing the two disks **130, 140** that are each made of a substantially clear or at least mostly light-translucent material such as a glass, a ceramic, or a plastic such as an acrylic. For example, the material used for the bodies of the disks **130, 140** may be chosen to have an index of refraction that is similar to water such as a durable material such as an acrylic or a molded urethane resin that is “water clear” and ultraviolet stabilized. The index of refraction will typically be the same or similar for each of the disks **130, 140** and may be within about 20 percent of water’s index of refraction such that it refracts light **172** from a light source **170** similar to water. For example, the index of refraction of the disks **130, 140** may be at least 1.3 such as in the range of 1.3 to 1.5. The disks **130, 140** are illuminated with a light source **170** with light **172** that strikes the disks **130, 140** at nearly any orientation and creates an optical effect as light passes through the disks **130, 140** that the rotating **131, 141** disks **130, 140** are water fans or circular fountains of water rather than being formed of a solid or rigid material. The system **100** may be adapted for using ambient light such as for outdoor use with the light source **170** being the Sun or manmade/provided outdoor lighting. In other cases, lighting sources such as would be used for a standard fountain may be provided such as lights positioned within the base housing **110** or elsewhere.

Each disk **130, 140** has a planar body with a generally circular shape and thickness, t_{Disk} that may vary from less than an inch in some smaller applications (such as less than 0.5 inches for a desk top system **100**) to 2 or more inches thick for larger application (such as 2 inches for an outdoor application with a disk OD of up to 7 feet or more). Some embodiments using a single design for each disk **130, 140** (e.g., formed of acrylic from a single mold) while other embodiments provide some variation between the configurations to achieve a desired optical effect. Each disk **130, 140** includes an inner (or inward facing) side or surface **132, 142** that may be substantially planar or smooth to provide a desired refraction of light **172** as it passes through the disk **130, 140**. The inner sides **132, 142** are positioned adjacent to each other (facing each other) in the system **100** and spaced apart on the hub/axle **150** to allow counter rotation **131, 141** without friction or contact between the two disks **130, 140**.

The disks **130, 140** also include an outer (or outward facing) side or surface **134, 144** that is contoured with a pattern of raised or protruding ridges or ribs that are arcuate or bowed in shape and extend from a disk center toward or to the sidewall or edge **136, 146**. Each of the ridges is spaced apart from an adjacent pair of the ridges with each ridge facing a single direction or having its outward curved portion (or

convex direction) directed in a like direction to form a pattern with arcuate ridges (e.g., appearing as spokes of a bowed wheel or the like when viewed along the rotation axis **154**), and during operation of the system **100**, the rotation such as rotation **131** is in the direction of the outward curve or bowing of the ridges/ribs on surface **134**.

In addition to the raised, arcuate ridges, the surface **134, 144** may include a non planar or 3D topography in between the ridges (or in the lower surface or the valleys of surface/side **134, 144**) to further cause refraction of light as would occur if the disks **130, 140** were formed of a fan or sheet of water. The relief or depth, d_{Relief} of the valleys (or height of the ridges) on surfaces **134, 144** may also vary to practice the system **100**, but, in some embodiments, the relief is about 25 to 50 percent or more of the disk thickness, t_{Disk} (e.g., a disk **130, 140** with a thickness, t_{Disk} of 2 inches may have a relief, d_{Relief} of 0.5 to 1 inches) To further the water fan effect, the sidewalls **136, 146** may also be formed with an irregular pattern or surface such as a jagged edging with peaks and valleys (or a serrated pattern) simulating an irregular travel of water spouts or jets from fountain nozzles.

FIGS. 2-4 illustrate one embodiment of a water disk effect assembly or system **200** that may be used to create a water disk or fan effect without spraying water into the air. The assembly **200** may utilize an ambient light source **204** (such as the Sun) or the like to provide light **206** for illumination. To refract the light **206** in a desirable manner, the assembly **200** includes a pair of disks **220, 320** that rotate in opposite directions as shown at **221, 321**. For example, when viewed from disk **220** side, the disk **220** is rotated **221** counterclockwise while the disk **320** is rotated **321** clockwise. As shown in FIG. 2, the disks **220, 320** are supported and positioned within a base or housing **210** above floor or platform **214**, which may have water **212** flowing over it and out of the walls of housing **210** to further the illusion that the disks **220, 320** are formed of water.

The bottom or lower portions of the disks **220, 320** may also be hidden from view within the housing **210** or its walls. This may be used to hide the full shape or size of the disks **220, 320** such as by providing the appearance that the disks **220, 320** are only a partial disk or fan as would be the case for a fountain. To this end, the base housing **210** may have walls or other components to hide at least about one fourth of the disks **220, 320** (e.g., a wall that extends at least about 0.25 times the OD of the disks **220, 320** above a lower edge **228, 328** of the disks **220, 320** (or lower point in a rotation of a moving **221, 321** disk **220, 320**)), but a specific amount that may be hidden from view may depend on a variety of design parameters such as whether viewers are below, on the same level, or above the housing **210** as this will effect a viewer’s line of sight to the disks **220, 320**.

The disks **220, 320** are spun or rotated **221, 321** by a drive assembly **240** that is hidden out of sight of viewers such as beneath the platform **214** on mounting structure **246**. In the embodiment shown in FIGS. 2 and 3, the drive assembly **240** includes a first drive wheel **244** driven by motor **242**. The wheel **244** abuts the sidewall **228** of disk **220** such that when the wheel **244** rotates as shown at **245** the disk **220** rotates, too, but in the opposite direction as shown at **221** about a hub or axle **350**, which may extend through the center of the disk **220** (as well as through the center of disk **320** such that the disks **220, 320** rotate about a common rotation axis). Similarly, the drive assembly **240** may include a second drive wheel **344** that abuts/contacts (or engages) the disk **320** such that when the wheel **344** is rotated **345** by a drive motor **342** the disk **320** also rotates **321** but in an opposite direction relative to the drive wheel **344**. The motors **242, 342** may be

operated to spin in opposite directions such that the drive wheels **244**, **344** and, hence, driven disks **220**, **320** counter rotate as shown at **221**, **321**.

As discussed with reference to FIG. 1, the rate of rotation **221**, **321** may vary to create a desired effect but typically may range from about 10 to 40 RPM with some embodiments having rotation rates of 20 to 30 RPM. Likewise, the rates of rotation **221**, **321** may be substantially similar or even nearly equivalent (e.g., both disks **220**, **320** rotating at about 25 RPM) or may differ slightly from each other (e.g., differ by less than about 7 RPM such as less than 4 RPMs such that a human eye cannot detect the existence of two separate, spinning disks). To hide rotational hub **350** and vertical support of the disks **220**, **320** within assembly **200**, hub covers or enclosures (or sculptural elements) **230**, **330** may be provided to conceal the hub **350**, which typically will extend through both disks **220**, **320**. The covers/enclosures **230**, **330** may also be chosen to contribute to the theme of the water disk effect such as by providing a reason for the water disk (e.g., a tail of a peacock or the like).

As discussed with reference to FIG. 1, the disks **220**, **320** may have a similar design and configuration but be positioned to face opposite directions and be counter rotated (e.g., rotation directions **221**, **321** differ or are in opposition about hub **350**). Each disk **220**, includes an outer surface or side **222**, **322** that is textured with a pattern of side-by-side but spaced apart ridges or ribs **224**, **324**, which each are raised or protruding some distance from the body of disks **220**, **320** (such as up to 1 inch or more depending on the thickness of the body of the disks to provide a desired amount of relief or topography for light refraction to achieve a water-like effect). In between each ridge **224**, **324**, the outer surface/side **222**, **322** is a rippled or textured surface (or valley) **225**, **325**, with a much smaller relief (such as up to 10 to 30 percent of the relief or height of ridges **224**, **324**) but providing varying refractive surfaces to better simulate water effects with disks **220**, **320**. The edges or sidewalls **228**, **328** of the disks **220**, **320** may also be serrated or irregular as shown to further the simulation of a non-perfect water effect and to disguise use of solid disks in assembly **200**.

As shown in FIG. 2, the bowed/arcuate and raised/protruding ridges **224**, **324** may each be similar in shape and size but often some variance between the ridges is intentionally provided to imitate the imperfect sprays achieved by a water fountain (e.g. the curvature or radius may not be repeated for each ridge **224**, **324**, the reach or lengths may be varied, and so on). In one embodiment, the surface **222**, **322** is patterned by setting a particular pattern of ridges **224**, **324** and textured valleys **225**, **325** for each quadrant and then four identical quadrants are used to create a mold for forming the disk **220**, **320** (which provides a balanced disk **220**, **320** for rotation and a repeating water effect with desired light refraction/transmission). Transmission or refraction of light is further controlled by having each disk **220**, **320** include a planar or substantially flat/smooth inner surface **223**, **323**, and these two surfaces **223**, **323** are positioned adjacent or facing each other with a small gap **320** (to facilitate counter rotation of the disks **220**, **320**). In use, refraction of light **206** occurs mainly at the surfaces **222**, **322** and due to the pattern or 3D topography of these surfaces **222**, **322** and not at inner surface/sides **223**, **323**.

FIG. 4 illustrates the assembly **200** without the housing **210** showing use of the assembly **200** to create a water disk or fan effect. As shown, the existence of the ribs/ridges **224**, **324** and contoured/rippled valleys **225**, **325** provides an appearance of a wall or disk of water rather than two spinning disks **220**, **320**. This is believed to be due to the use of two counter

rotating disks **220**, **320** that are patterned as described. Note, the reverse or opposing positioning of the disks **220**, **320** on the hub **350** causes the curved or arcuate ridges **224**, **324** to face in opposite directions (e.g., with their convexness or bow in opposite directions). For example, when the assembly **200** is viewed from the side of the disk **220**, the ridges **224** of disk **220** bow or curve to the left while the ridges **324** of the disk **320** bow or curve to the right.

During operation, the disks **220**, **320** are rotated **221**, **321** in a direction that coincides or matches the direction of the ridges **224**, **324**, e.g. with the rotation **221** being to the left or counterclockwise while the rotation **321** is to the right with the bowing of the ridges **324** or clockwise. When light **206** from source **204** passes through the disks **220**, **320**, a viewer's eyes tend to watch or view the interference between pairs of ridges **224**, **324** in the counter rotating disks **220**, **320**. For example, as the disks rotate **221**, **321** a pair of adjacent ridges **224**, **324** may have their base portions first overlapping or interfering and then their middle portions followed by their tips. This interference in the transmission of light **206** happens rapidly and in a repeated manner for adjacent pairs of ridges **224**, **324** such that the viewer believes they see jets of water shooting outward from the base housing **210** with radial flow. The material(s) used to form the disks **220**, **320** may be the same for each disk, and it is typically selected to provide an index of refraction that is similar to water's index of refraction (such as within 20 to 30 percent of the index of refraction of water), with some embodiments using materials that provide an index of refraction of at least about 1.3. For example, the disks **220**, **320** may be formed of glass, ceramic, acrylic, plastic, or the like (such as from a water clear, UV-stabilized urethane resin or the like).

As can be understood from the above discussion of the systems **100** and **200**, the water disk effect is achieved by providing two disks made of a durable material with that is about as clear or transmissive of light as water such as certain acrylics, glasses, and other materials. The disks each have water, spiral patterns sculpted onto the outer surfaces or outer faces of the disk bodies. The inner faces of each disk are flat, which forces light traveling through the disks to distort and bend the same way or in a similar manner that light bends as it passes through water. The disks are rotated in opposite directions about a common rotation axis to cause the patterns on the outer surfaces to create the illusion of outward movement. Because the disks are made of a material that mimics the color and light transmission qualities of water, the effect appears to be radially outward moving water. The point of rotation between the disks may be covered to hide the mechanism that turns the disks. The lower portion of the disks (such as at least one fourth) may be obscured or hidden from view, thereby forcing the viewers to imagine or believe that the "water" is dropping out of sight into the supporting base or pool of water of a "fountain."

FIG. 5 illustrates an exemplary disk **510** that may be used for the two disks in a water disk effect assembly (such assemblies **100**, **200**). The disk **510** may have a body with an OD, OD_{Disk} , that will vary to suit an application from several inches in a desk top or toy application to several feet (e.g., 2 to 7 feet or more) for a larger indoor or an outdoor implementation (such as for an amusement park ride, for a building water effect, and so on). The body of the disk **510** may have an irregularly shaped or textured edge or sidewall **512** with a thickness of less than one inch up to several inches (as measured from a flat or planar back or inner surface (not shown in FIG. 5) to the outer face or outward facing surface **516**). The body of the disk **510** is formed of materials with colors and

transmissivity similar to water (e.g., light blue or green (or colorless) glass or plastic with an index of refraction near 1.3 or the like).

The outer face or surface **516** is textured to have a 3D topography with a pattern of a plurality or set of raised ridges **520**, which may have a height or relief of 25 to 50 percent of the thickness of the disk body (such as 0.75 inches when the disk **510** is 2 inches thick in one embodiment). As shown, each ridge element **520** includes a central ridgeline or top/peak **522** with an arcuate or bowed shape and a pair of ridge bottoms or edges **524**, **526**, which are also bowed or arcuate. The ridge element **520** may have a thickness, t , that is measured from ridge bottom/edge **524** to ridge bottom/edge **526**, and this thickness, t , may be constant along the length of the ridge element **520** or may be smaller near a center hole/opening **514** (used to rotatably mount the disk **510** in an assembly).

Each neighboring or adjacent ridge/rib element **530** is also arcuate and is spaced apart from the ridge element **520** to define a valley with a width, w_{valley} , which as with the thickness, t , may increase in size with distance from the center hole **514** to simulate radially sprayed and/or rotated water jets. The valley typically will include a contoured or rippled surface **540** (random 3D topography) that acts to refract received light in an unpredictable or irregular manner as is the case with water dispersed in a fountain between water jets or in a wall/sheet of water. Each ridge **520**, **530** may extend completely from the center hole **514** to the edge or sidewall **512** or may be spaced apart from both or at least the edge/sidewall **512** a distance, gap_{Edge} , defining a gap and this gap distance may be varied among the ridge elements **520**, **530** to further the illusion of varying shape and size of ridge or raised elements **520**, **530** as may occur in a water-based fountain.

The specific magnitude of these dimensions/parameters as well as the particular radius or amount of curvature of the arcuate ridge elements **520**, **530** may be varied widely to practice the invention. However, FIG. 5 is useful for showing that the ridge elements **520**, **530** typically are not planar elements but slope downward into a valley from a ridgeline **522** and for showing that there is often a gap or spacing between adjacent or neighboring ridge components **520**, **530** so as to define separate “jets” of water with the space or valley between being, in some cases, textured to provide a more continuous water distortion effect with transmittal of incident light.

The technique or method used to drive or rotate the disks in differing directions may also be varied to practice the invention. FIG. 6 illustrates a water disk effect system **600** with similar components as found in system **200** but with a differing drive configuration. As shown, the pair of disks **220**, **320** is again mounted within a housing **210** that hides the lower portions and provides for concurrent rotation about a common rotation axis with central axis component or hub **350** supporting both the disks **220**, **320**. In this system **600**, a pair of motors **608** and **610** is mounted within the hub enclosures **230**, **330** and mechanically connected to or linked to the disks **220**, **320** to selectively rotate **221**, **321** the disks at the same or differing rotation rates and in differing/opposite directions as shown about hub **350**.

In some cases, the motors **608**, **610** may be electric motors or other motors (or similar devices) that may be operated separately or in linked manner to counter rotate the disks **220**, **320** (such as at substantially equal (within a few RPMs) rotation rates in the range of 20 to 30 RPMs or the like). The motors **608**, **610** may also be adapted for remote operation based on power or control signals, and the motors **608**, **610** may be operable at two or more speeds to allow tuning of the

rotations **221**, **321** to suit a particular application (e.g., to tune the rotation rate based on the textured surfaces **222**, **322**, the lighting **206**, and other operating parameters that may affect achieved optical effects).

FIG. 7 illustrates another water disk effect assembly **700** that includes similar components (with like numbering) as assemblies **200** and **600** but with a differing drive arrangement for disks **220**, **320**. Specifically, the assembly **700** includes a pair of motors **720**, **721** within housing **210** that are separately operable at the same or differing speeds to impart counter rotation **221**, **321** of the disks **220**, **320**. This may be achieved by rotation of a shaft or gears/sprockets **722**, **723** to drive belt, chains, gear trains, or the like **724**, **725** to rotate the disks **220**, **320** via shafts or hub stubs **709**, **711** that are affixed or mated with the disks **220**, **320** (such as pivotally supported upon the shaft or hub **350**, which in turn is supported by enclosures **230**, **330**). Again, the rotations **221**, **321** are in opposite directions and may be the same or nearly so (such as a rotation rate selected from the range of 10 to 40 RPMs) or intentionally differing (e.g., disk **220** may rotate **221** at a fixed rate (such as 25 RPM) while disk **320** may rotate **321** in the opposite direction at a fixed rate within several RPMs of disk **220** (such as a rate in the range of 22 to 28 RPMs) or at a rate that is varied over time about the rate of disk **220** (such as within the range of 23 to 27 RPMs or the like)).

Although the invention has been described and illustrated with a certain degree of particularity, it is understood that the present disclosure has been made only by way of example, and that numerous changes in the combination and arrangement of parts can be resorted to by those skilled in the art without departing from the spirit and scope of the invention, as hereinafter claimed. Many of the specific examples described the use of the counter-rotating disks to simulate a fan-shaped fountain of water, but the concepts are equally applicable to other liquids. The fan-shaped fountain effect may be used to look like nearly any transparent to translucent liquid by adjusting the patterns on the disk surfaces and/or adjusting design parameters such as the index of refraction, the color of the disk bodies, the rotation rates, and so on. If it were desirable for the disks to be used to simulate a fan of a thicker or more viscous material such as honey, the disks may be formed from a honey-colored material with a refraction of index similar to honey. The disks may be shaped with slightly broader and “gooier” patterns of ridges, with the disks rotated at slower rotation rates (or toward the lower end of the ranges provided herein).

I claim:

1. An apparatus for providing a water disk effect, comprising:
 - a first disk;
 - a second disk, wherein the first and second disks each have a first side with a substantially planar surface and a second side with a surface textured with a three dimensional (3D) pattern including ridges and valleys and wherein the first and second disks are at least translucent to light;
 - a housing supporting the first and second disks, wherein the first and second disks are mounted for independent rotation about a common rotation axis extending through a center of each of the disks and wherein the first side of the first disk is positioned adjacent and proximate the first side of the second disk, whereby the second sides of the first and second disk face outward in the apparatus; and
 - a drive assembly adapted for rotating the first disk in a first direction about the rotation axis and for concurrently

11

rotating the second disk in a second direction about the rotation axis that is opposite the first direction, wherein the index of refraction of at least the first and second disks is substantially identical and wherein paired, adjacent portions of the 3D pattern on the first and second disks produce interference during light transmission through the first and second disks.

2. The apparatus of claim 1, wherein the 3D pattern comprises a plurality of arcuate ridges extending generally from a center of the first and second disks toward an outer edge.

3. The apparatus of claim 2, wherein the arcuate ridges of each of the first and second disks are curved in a common direction relative to the center of the disk.

4. The apparatus of claim 3, wherein the common curve direction coincides with the first direction of rotation for the first disk and the common curve direction coincides with the second direction for the second disk.

5. The apparatus of claim 2, wherein the 3D pattern further comprises an irregular textured surface in a gap between each adjacent pair of the arcuate ridges.

6. The apparatus of claim 2, wherein the arcuate ridges on each of the disks have a height of at least about 25 percent of a thickness of each of the disks.

7. The apparatus of claim 1, wherein the first and second disks are formed from a material with an index of refraction of at least about 1.3.

8. The apparatus of claim 1, wherein the drive assembly comprises a first drive mechanism driving the first disk in the first direction at a rotation rate in the range of about 20 to about 30 revolutions per minute and a second drive mechanism driving the second disk in the second direction at a rotation rate in the range of about 20 to about 30 revolutions per minute (RPM).

9. The apparatus of claim 8, wherein the rotation rates of the first and second disks differs by less than about 3 RPM.

10. The apparatus of claim 1, further comprising an axle for supporting the first and second disks and extending through the centers of the first and second disks, wherein the housing further includes an enclosure assembly extending over the axle proximate to the second side of the first and second disks, and wherein the disks are supported such that at least one fourth of the disks extend into the housing.

11. The apparatus of claim 1, wherein at least a bottom fourth of the first and second disks extends into the housing during rotation by the drive assembly, whereby view of the at least bottom fourth is hidden from view.

12. A system for providing a water-like visual effect, comprising:

a pair of planar disks pivotally supported on an axle and arranged parallel to each other, wherein each of the disks includes an outer surface with a set of side-by-side, raised, arcuate elements and wherein each of the disks is at least translucent to light such that light striking one of the outer surfaces passes through both of the disks;

a first drive mechanism spinning a first of the planar disks in a first direction about the axle; and

a second drive mechanism concurrently spinning a second of the planar disks about the axle in a second direction opposite the first direction,

wherein the arcuate elements on the first of the planar disks are all convex in a first direction and the arcuate elements

12

on the second of the planar disks are all convex in a second direction that is opposite the first direction of the arcuate elements,

wherein the first direction of the arcuate elements corresponds to the first direction of rotation, and wherein the second direction of the arcuate elements corresponds to the second direction.

13. The system of claim 12, wherein the planar disks comprise a body with an index of refraction of at least about 1.3.

14. The system of claim 12, wherein the first and second planar disks are rotated at rates in the range of 10 to 40 RPM.

15. An optical effect apparatus, comprising:

a first disk with a planar body having a side with a 3D topography including a plurality of arcuate ridges arranged to be spaced apart and side-by-side about a center point of the first disk, the planar body being translucent to light and having an index of refraction of at least about 1.3;

a second disk with a planar body having a side with a 3D topography including a plurality of arcuate ridges arranged to be spaced apart and side-by-side about a center of the second disk, the planar body being translucent to light and having an index of refraction of at least about 1.3;

a support structure supporting the first and second disks for independent rotation about a rotation axis extending through centers of the first and second disks, wherein the first and second disks are positioned to be parallel to each other with the sides with the 3D topography facing outward; and

a drive assembly adapted to rotate the first disk at a first rotation rate in a first direction about the rotation axis and to concurrently rotate the second disk at a second rotation rate in a second direction about the rotation axis, the first direction being opposite the second direction.

16. The apparatus of claim 15, wherein the arcuate ridges of the first disk are bowed outward in a first direction coinciding with the first direction of rotation and wherein the arcuate ridges of the second disk are bowed outward in a second direction coinciding with the second direction of rotation when the first and second disks are viewed along the axis of rotation.

17. The apparatus of claim 15, wherein the first and second rotation rates are in the range of about 20 to about 30 RPM and wherein the first rotation rate is within about 3 RPM of the second rotation rate.

18. The apparatus of claim 15, wherein the first and second disks each further includes a side, opposite the side with the 3D topography, that has a substantially planar surface and wherein the planar surfaces of the first and second disks are spaced apart.

19. The apparatus of claim 15, further including a housing and wherein the first and second disks extend into the housing such that at least about one fourth of the first and second disks are contained within the housing as measured by the outer diameter of the first and second disks, whereby at least a lower portion of the first and second disks is concealed from view during use of the apparatus.