



US007883212B2

(12) **United States Patent**
O'Connell et al.

(10) **Patent No.:** **US 7,883,212 B2**

(45) **Date of Patent:** **Feb. 8, 2011**

(54) **PROJECTION APPARATUS AND METHOD FOR PEPPER'S GHOST ILLUSION**

(56) **References Cited**

U.S. PATENT DOCUMENTS

(76) Inventors: **Ian O'Connell**, c/o Musion Systems Limited, Covden House, 7a Langley Street, London (GB) WC2H 9JA; **James Rock**, c/o Musion Systems Limited, Covden House, 7a Langley Street, London (GB) WC2H 9JA

221,605 A	11/1879	Pepper et al.	
2,991,841 A	7/1961	Sampson et al.	
4,019,656 A *	4/1977	Spears	222/103
4,805,895 A	2/1989	Rogers	
4,927,238 A *	5/1990	Green et al.	359/466
5,255,028 A	10/1993	Biles	
5,573,325 A	11/1996	Lekowski	
5,685,625 A	11/1997	Beaver	

(*) Notice: Subject to any disclaimer, the term of this patent is extended or adjusted under 35 U.S.C. 154(b) by 1129 days.

(Continued)

FOREIGN PATENT DOCUMENTS

(21) Appl. No.: **10/599,553**

EP 0 919 258 6/1999

(22) PCT Filed: **Apr. 1, 2004**

(86) PCT No.: **PCT/GB2004/001414**

§ 371 (c)(1),
(2), (4) Date: **Sep. 30, 2006**

(Continued)

(87) PCT Pub. No.: **WO2005/096095**

Primary Examiner—Georgia Y Epps
Assistant Examiner—Ryan Howard
(74) *Attorney, Agent, or Firm*—Thomas, Kayden, Horstemeyer & Risley, LLP; Larry W. Brantley

PCT Pub. Date: **Oct. 13, 2005**

(65) **Prior Publication Data**

(57) **ABSTRACT**

US 2007/0201004 A1 Aug. 30, 2007

(51) **Int. Cl.**
G03B 21/00 (2006.01)
G03B 21/56 (2006.01)
G02B 27/22 (2006.01)
A63G 31/00 (2006.01)
A63J 5/00 (2006.01)

An image projection apparatus (100) comprises a projector (106), a frame (108), and a partially transparent screen (110). The frame (108) retains the screen (110) under tension, such that the screen (110) is inclined at an angle with respect to a plane of emission of light from the projector (106). The screen (110) has a front surface arranged such that light emitted from the projector (106) is reflected therefrom. The projector (106) projects an image such that light forming the image impinges upon the screen (11) such that a virtual image is created from light reflected from the screen (110), the virtual image appearing to be located behind the screen (110).

(52) **U.S. Cl.** **353/10**; 359/449; 359/478; 472/63

(58) **Field of Classification Search** 353/10, 353/74, 79, 119, 122, 28; 359/443, 449, 359/447, 478, 479, 630; 472/58, 61, 63

See application file for complete search history.

18 Claims, 4 Drawing Sheets

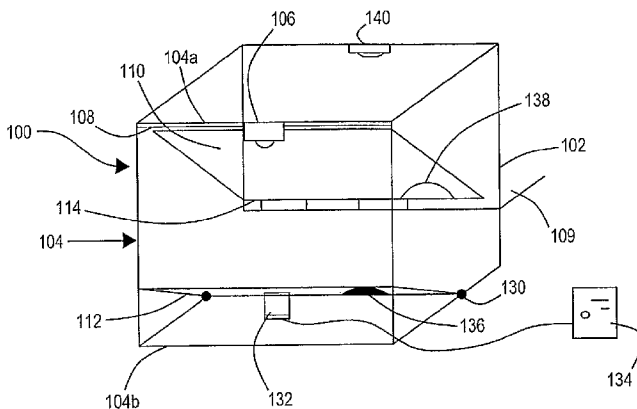

U.S. PATENT DOCUMENTS

5,809,624 A 9/1998 Nakamae et al.
5,865,519 A 2/1999 Maass
5,944,403 A 8/1999 Krause
5,964,064 A 10/1999 Goddard et al.
6,129,649 A 10/2000 Yang
6,341,868 B1 1/2002 Shriver
6,364,490 B1 4/2002 Krause
6,481,851 B1 11/2002 McNelley et al.
6,817,716 B1 11/2004 Hines

2003/0117583 A1 6/2003 Werhahn-Wunderlich
2003/0174292 A1 9/2003 White
2004/0036844 A1 2/2004 Wood et al.

FOREIGN PATENT DOCUMENTS

EP 0 919 258 A2 6/1999
FR 2 793 062 11/2000
FR 2 793 062 A1 11/2002

* cited by examiner

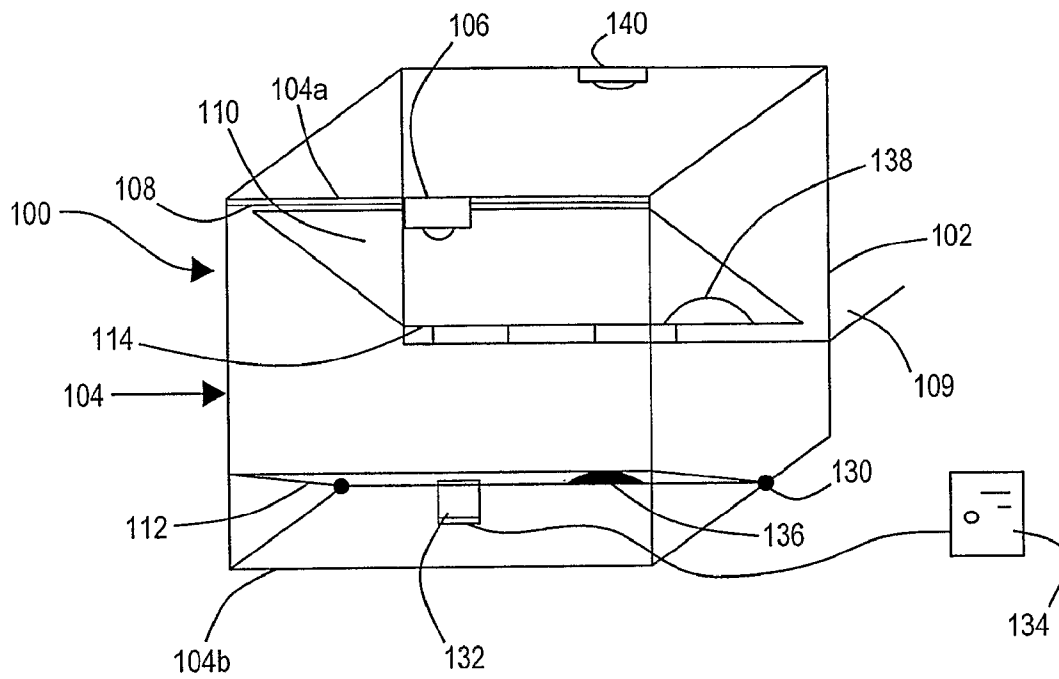

Fig. 1

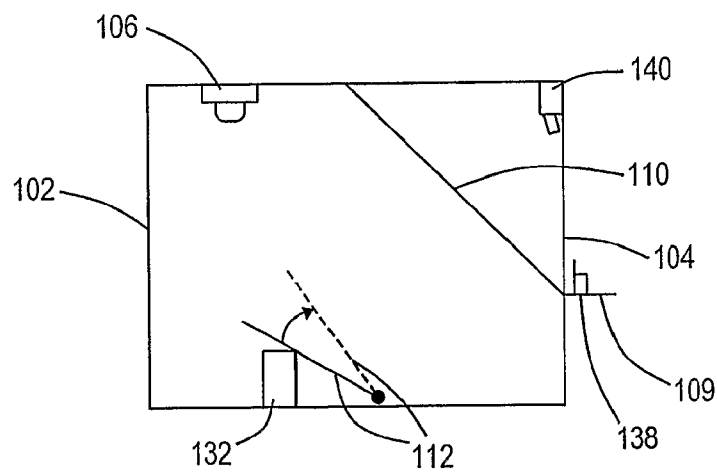

Fig. 2

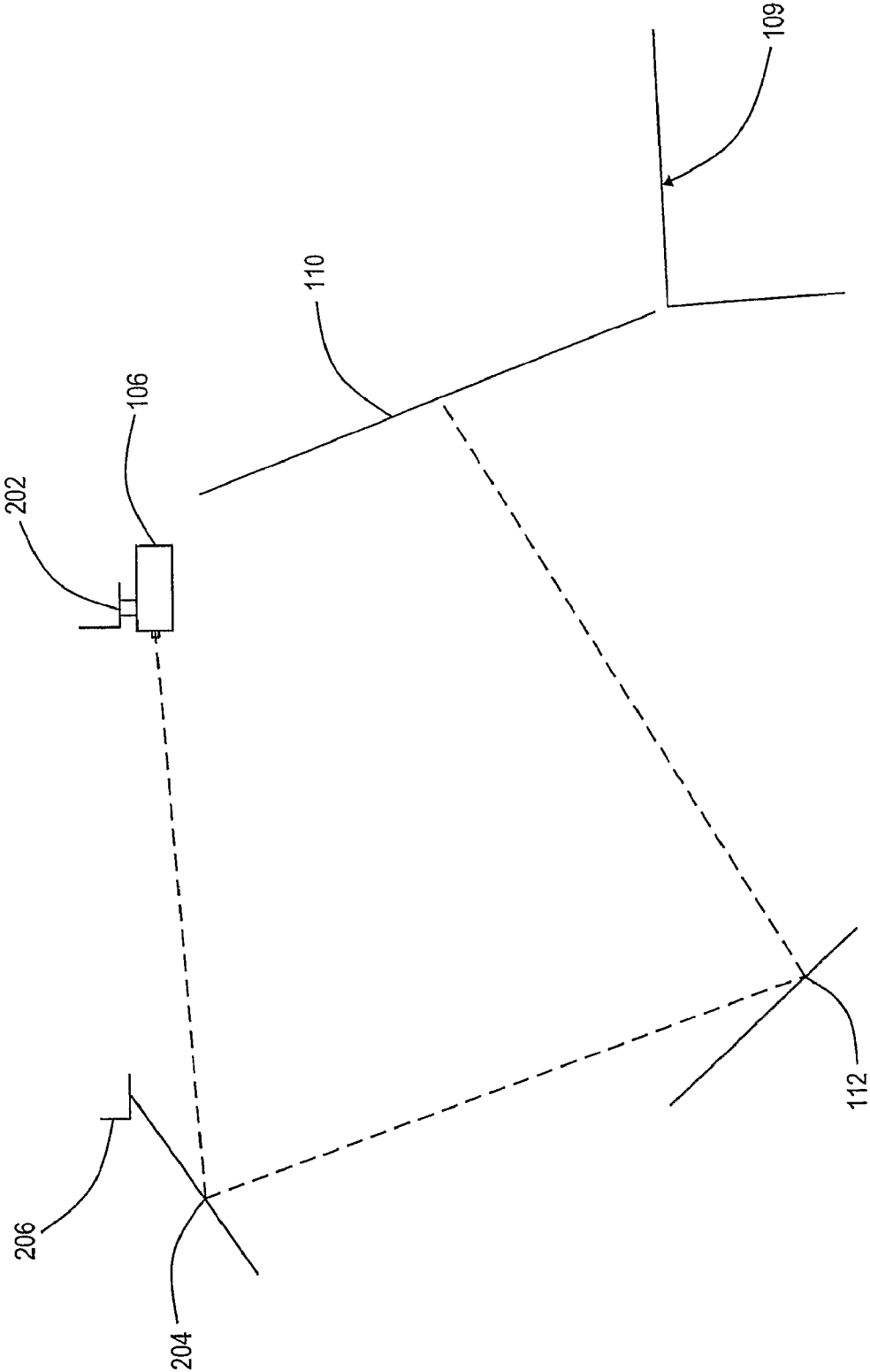

Fig. 2a

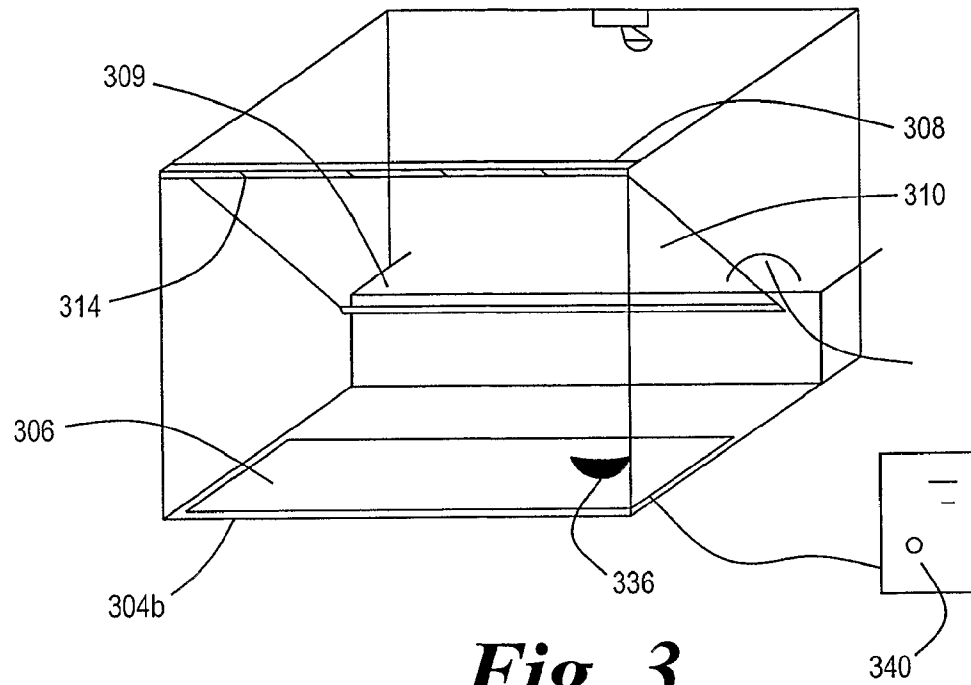

Fig. 3

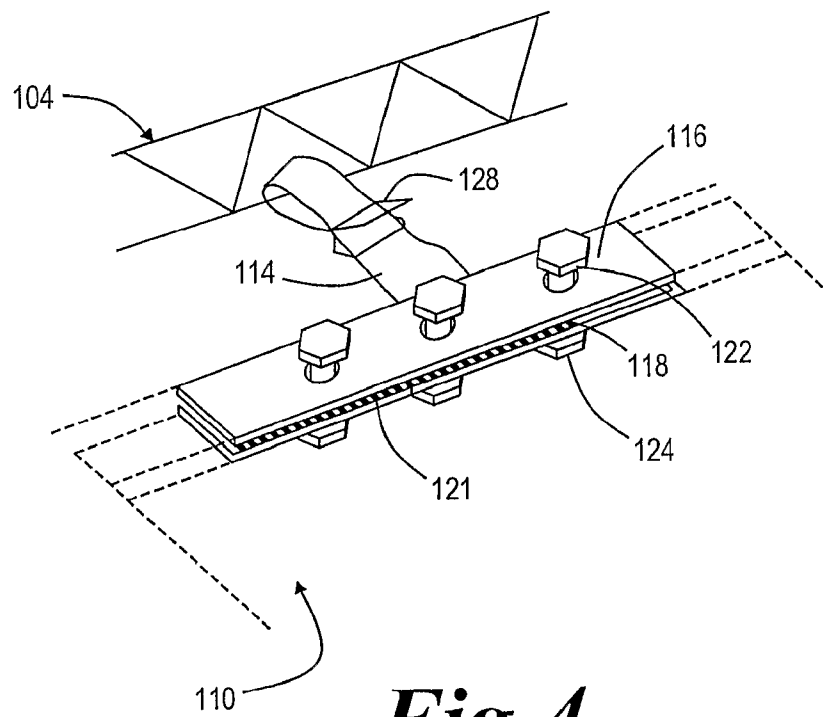

Fig. 4

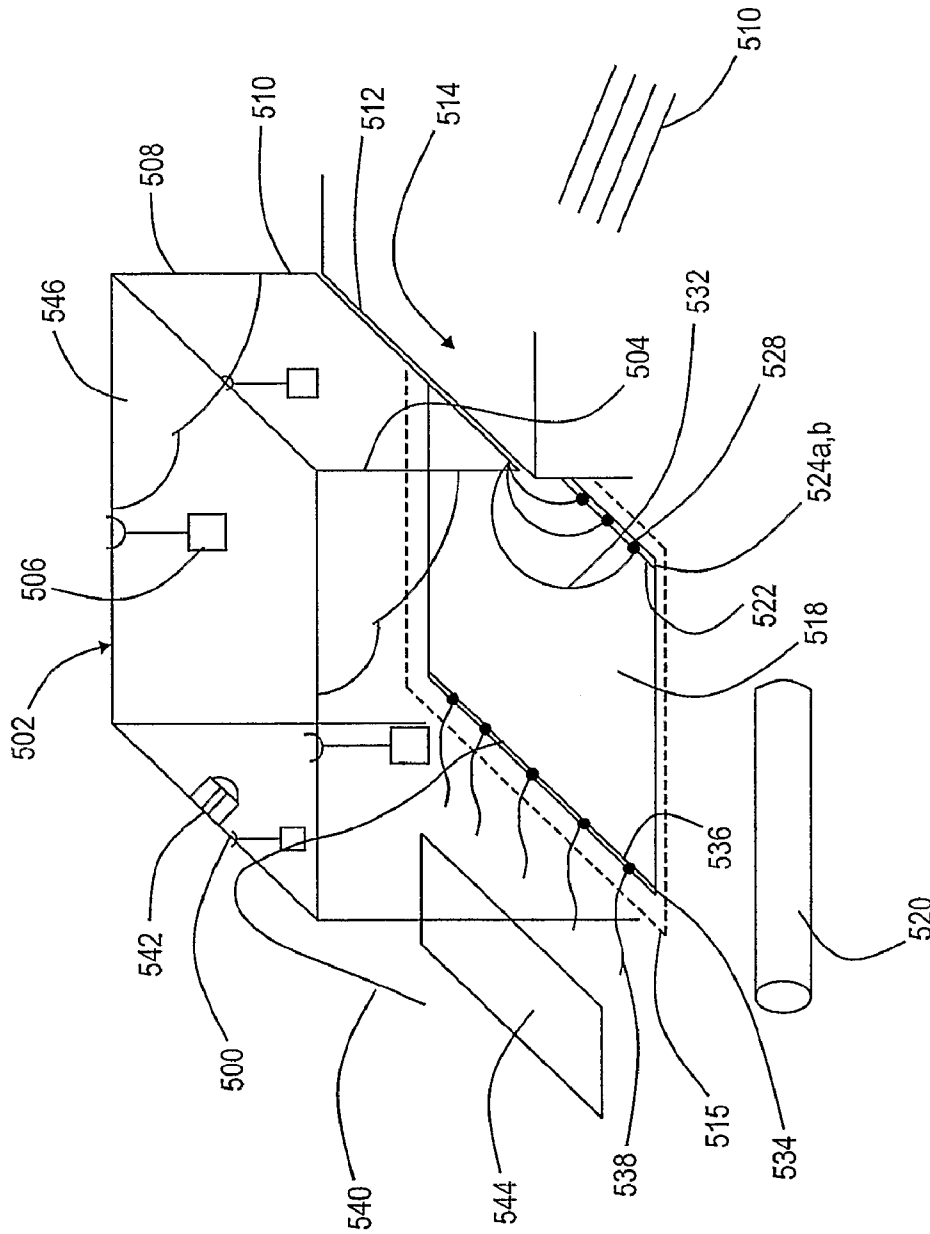

Fig. 5

PROJECTION APPARATUS AND METHOD FOR PEPPER'S GHOST ILLUSION

This invention relates to a projection apparatus and method. More particularly, but not exclusively, it relates to a projection apparatus arranged to project an image of an object upon an inclined, partially reflective, screen so as to give a false perception of depth and a method for constructing such an apparatus.

BACKGROUND OF THE INVENTION

The projection of an image upon a partially reflective screen such that is observable by a viewer positioned in front of the screen is known, the so-called "Peppers ghost" arrangement that is known from fairground shows.

This has been applied to publicity and promotional displays where a presenter resides behind an inclined, partially reflective screen, typically a tensioned foil, onto which an image of, for example, a motor vehicle is projected, via at least one reflective surface, see for example EP 0799436. The location of the presenter behind the projected image has a number of inherent advantages over systems where the presenter stands in front of a screen, not least of which is that the presenter does not obscure the projected image when walking across the projected image. Additionally, the use of an inclined screen results in a viewer of the image perceiving the image as having depth rather than merely being a two dimensional image, for example where a motor vehicle is seen to rotate upon a turntable.

However, current image projection apparatus' do have a number of problems associated with them, for example, mounting of the foil can prove difficult which in turn leads to uneven tensioning of the foil and wrinkles upon the foil, that impair the viewed quality of the image projected onto the foil. Also, in mounting the foil the foil must be laid out upon a clean dust free piece of cloth or plastic sheet, which is larger than the foil, in order to prevent particles adhering to the foil, such particles can scratch the surface of the foil and impair the viewed quality of the projected image or act as scattering centres from which projected light is incoherently scattered, thereby detracting from the viewed quality of the image as this scattered light does not contribute to the viewed image.

Also, as the illusion of peppers ghost relies on the reflected image formed by light contrasting with its immediate surroundings and background. The stronger the reflected image, the more solid that reflected image looks, the more vibrant the colours will be, and the more visible the reflected image is to an audience. In circumstances where the presenter may be unable to control high levels of ambient light forward of the foil, e.g. from an auditorium at a trade show, the high level of ambient light results in significant levels of reflection of the ambient light from the screen detracting from the strength of the reflected image over the background. In these circumstances a bright projector (8000 lumens+) is desirable. However, the use of a bright projector results in unwanted light hitting the projection surface and reflecting through the foil to create a milky hue upon the stage and around the area where the reflected image appears.

Another problem with current image projection apparatus is that projectors used with such apparatus are very powerful, typically 8,000 to 27,000 lumens and consequently project a significant amount of light into areas of an image where there is no object within the image. This is an inherent feature of projectors and results in low contrast ratios which leads to a milky hue spread over the part of the film where the projector is creating an image when the projector is switched on. The

milky hue is clearly undesirable as it detracts from the viewer's perception that there is no screen present.

The level of the milky hue relative to the brightness of the image is, at least partially, determined by the level of contrast ratio offered in the projector. The higher the contrast ratio, then the brighter the image can be relative to the brightness level of the milky hue. Even projectors with contrast ratios as high as 3000:1 still emit a milky light hue when used in a "Pepper's Ghost" arrangement.

A further problem associated with some projectors is the "keystone" effect, in which distorted, typically elongated, images (up and down) occur due to angled projection. This is of particular relevance where depth perception is of importance. The solution employed in modern, expensive projectors is to employ digital correction of keystone distortions. However, older, less-expensive or even some specialist High Definition projectors do not employ such digital keystone correction and are therefore difficult to configure for use with current image projection apparatus. High definition (HD) projectors do not offer keystone adjustment because when keystone correction is attempted in conjunction with the increased number of pixels about an image's edge causes the pixels about the edge of the image to appear 'crunched'. Additionally, when processing moving images HD projectors compromise projector processing speed. When the processing power is used to carry out both keystone correction and motion processing the image is seen to jerk during movements, an effect known as "chokking". In general, it can be said that the use of electronic keystone correction to alter a video image will result in the degradation of picture quality compared to an image which is not subject to such a process.

Additionally, current systems do not allow for the projected image to apparently disappear and re-appear from behind a solid 3D object placed upon the stage, as the screen lies in front of the presenter and closest to the viewing audience.

BRIEF SUMMARY OF THE INVENTION

According to a first aspect of the present invention there is provided a image projection apparatus comprising a projector, a frame, and an at least partially transparent screen:

the frame being arranged to retain the screen under tension, such that the screen is inclined at an angle with respect to a plane of emission of light from the projector;

the screen having a front surface arranged such that light emitted from the projector is reflected therefrom; and

the projector being arranged to project an image such that light forming the image impinges upon the screen such that a virtual image is created from light reflected from the screen, the virtual image appearing to be located behind the screen.

Such an apparatus is advantageous over present systems in that the screen need not be coated with an expensive, partially reflective coating, an angular dependence of reflectivity of transparent dielectric materials can be used to bring about partial reflectance of the projected image. Thus, this apparatus simplifies the manufacture of such systems and also reduces their production costs. Additionally, the use of a frame frees the screen from having to be fixed directly to a ceiling, or a floor, and therefore increases the utility of apparatus over the prior art systems.

The screen may be a foil. The foil may be rolled about a cylinder when not in use. The screen may be inclined at approximately 45° to the plane of emission of light from the projector. The screen may comprise a partially reflective layer upon the front surface.

The use of a foil screen reduces the weight of the apparatus, this allows ready transportation of the apparatus between sites. Rolling the foil onto a cylinder when not in use serves to protect the foil from damage during transportation and also allows ready transportation of the apparatus between sites. The use of a partially reflective screen can increase the degree of light reflected from the screen and can increase the audience perceived strength of the virtual image.

The screen may be attached to the frame at the screen's upper and/or lower edges. The frame may comprise first and second retention members arranged to sandwich an edge region of the screen therebetween. At least one of the first and second retention members may comprise an abrasive coating, typically sandpaper, arranged to contact the screen. The first and second retention members may comprise respective openings therethrough that may be arranged to collocate with openings in respective jaws of clamping members attached to tensioning straps, the openings may be arranged to receive a fixing means so as to clamp the screen between the first and second retention members. The tensioning straps may be attached to a truss arrangement and may be adjustable such that the tension of the screen within the truss arrangement can be varied about the periphery of the screen. Preferably, the retention members are substantially parallel to truss members comprising the truss arrangement.

The use of a variable tensioning arrangement allows wrinkles upon the screen to be minimised, and ideally eradicated to present a smooth surface for upon which the image can be projected. An abrasive surface upon at least one of the retention members increases the grip between the retention member and the screen thereby reducing the likelihood of the screen slipping when held by the retention member.

The apparatus may comprise a pigmented reflective member in an optical pathway between the projector and the screen. The pigmented member may reflect only part of the visible spectrum of light, typically the pigmented member will appear grey or white to a viewer.

It has been found that the use of a grey reflective member in the optical pathway between the projector and the screen reduces the outline of the reflective member upon the screen compared to when a white reflective member is used, and also reduces the level of the milky white hue associated with the projector emitting light where there is no image of an object to be projected.

The pigmented reflective member may be inclined at an angle with respect to the plane of emission of light from the projector. The angle of inclination of the member with respect to the plane of emission of light from the projector may be variable. The member may comprise a plurality of sections each of which may have an independently variable angle of inclination with respect to the plane of emission of light from the projector.

The inclination of the reflective member can compensate, at least partially and in some instances completely, for keystone effect. The variation of the angle of inclination or distance of the reflective member allows for a variation of the apparent depth and/or position of an object when projected upon the screen. This is because the virtual image appears as far behind the screen as the real image is in front of the screen.

There may be a reflective device, typically a mirror, arranged to direct light projected from the projector on to the reflective member. Typically, the reflective device is mounted upon an upper part of the framework. The reflective member may be parallel, or substantially parallel, to the reflective device. In some embodiments the projector may be mounted upon an upper truss of the framework and may be aligned with

the horizontal, typically light projected from the projector is directed on to the reflective device.

Such an arrangement compliments the keystone correction achievable by the inclination of the screen and the reflective member and is particularly useful where an HD projector is used in order to compensate for the keystone effect without the use of the projector's processing power.

The reflective member may comprise a mask corresponding to the apparent location of a prop in the screen to an audience. Typically, the mask will absorb light over at least a fraction of the visible spectrum and preferably the mask will be black. The mask may be arranged to produce an area upon the screen upon which the image is not projected. The mask may vary in extent and shape, for example by the use of a sliding element that is moved in and out of position upon the reflective member.

The mask can be used to make the illusion of an article disappearing and reappearing behind a prop that is placed upon a stage, either behind or in front of the screen.

The apparatus may comprise a light source arranged to selectively illuminate an area of stage comprising the prop. The light source may be a white light source. Lighting the prop causes the prop to become more visible and better defined against the dark, typically black, background. This enhances the three dimensional effect of the projected image interacting with the prop.

Also directing bright light upon the prop serves to reduce the contrast ratio of the projected image upon the prop, which typically remains slightly visible even when a mask is used in the prop's shadow upon the reflective member, thus enhancing the illusion of the projected image disappearing behind the prop.

The apparatus may comprise a light source arranged to illuminate at least part of a stage. The light source may be located to the rear of the screen, typically along a top edge of the frame and/or along either side of the stage. The apparatus may comprise a plurality of light sources. The apparatus may comprise a lighting desk equipped with faders arranged to control the level of each light source, or selection means arranged to selectively control the supply of power to each light source.

Such a light source is used in order that the colour and light levels of the area immediately surrounding the peppers ghost image, the stage background, can most closely match the colour of the projection surface background, excluding the area on both which is carrying the image. This, reduces the milky hue perceived by the audience. The use of a plurality of light sources increases the uniformity of lighting of the stage, in order to produce a similar effect to the way light emitted from a projector hits the projection screen. By controlling each light source separately the lighting levels upon the stage can be controlled to closely match the levels of light as dictated by the show performance, or the levels of unwanted light hitting the projection surface of the screen.

The projector may comprise a standard projector, for example a JVC ML4000, or a Barco G5. Alternatively, the projector may comprise an LCD, or a television display. The display may comprise at least one element arranged to be non-emitting in response to control from a processor. The at least one element may form a mask arranged to produce an area upon the screen upon which the image is not projected. The mask may correspond to the shape and location of a prop upon stage. The prop may be three dimensional.

5

According to a second aspect of the present invention there is provided a method of providing a projection apparatus comprising the steps of:

- (i) resting a frame upon a number of elevation means;
- (ii) attaching leg sections to the frame;
- (iii) increasing the height of the elevation means;
- (iv) adding further leg sections;
- (v) attaching a lower edge of a screen to a lower rear piece of the frame;
- (vi) raising an upper edge of the screen to adjacent an upper front section of the frame; and
- (vii) attaching the upper edge of the screen to the upper front section of the frame.

The method may comprise providing the elevation means in the form of a jack.

The method may comprise providing the screen in the form of a film. The method may comprise removing a roll of screen film from a protective cylindrical casing. The method may comprise laying the screen upon a dust-free protective sheet.

The method may comprise placing the lower edge of the screen between jaws of a first retention member and may further comprise securing the screen in position using a fixing means passing through the retention member and the screen and a locking means arranged to lock the fixing means being arranged to secure the locking means in position. The method may comprise providing the fixing means in the form of a bolt and the locking means in the form of a nut.

The method may comprise attaching tensioning means to the retention member adjacent at least some of the fixing means.

The method may comprise attaching the tensioning means to the lower rear piece of the frame.

The method may comprise attaching a second retention member to an upper edge of the film screen, typically in the same manner as the first retention member is attached to the lower edge. The method may comprise attaching tensioning means to the second retention member. The method may comprise providing the tensioning members in the form of ratchet straps.

The method may comprise attaching a rope to the second retention member and passing the rope over the upper frame and using the rope in step (vii) to raise the screen.

The method may include tensioning each of the tensioning means such that the screen is flat and substantially wrinkle free.

The method may include depending a projector from the upper frame.

The method may include placing a pigmented reflective board between the screen and a front edge of the frame. The method may comprise reflecting light emitted by the projector from the board onto the screen.

The method may comprise forming the frame form a truss work.

According to a third aspect of the present invention there is provided a projection apparatus constructed according to the second aspect of the present invention.

BRIEF DESCRIPTION OF THE SEVERAL VIEWS OF THE DRAWINGS

The invention will now be described, by way of example only, with reference to the accompanying drawings, in which:

6

FIG. 1 is a schematic representation of a first embodiment of a projection apparatus according to at least an aspect of the present invention;

FIG. 2 is a side view of a the projection apparatus of FIG. 1 showing a pigmented reflective member in first and second positions;

FIG. 2a is a schematic representation of an alternative projection arrangement, suitable for use with the apparatus of FIGS. 1 and 2;

FIG. 3 is a schematic representation of a second embodiment of a projection apparatus according to at least an aspect of the present invention;

FIG. 4 is a perspective view of a screen clamping arrangement of FIGS. 1, 2 and 3; and

FIG. 5 is a schematic view of a projection apparatus being constructed according to the second aspect of the present invention.

DETAILED DESCRIPTION OF THE INVENTION

Referring now to FIGS. 1, 2 and 4, a projection apparatus 100 comprises a box frame 102 formed of trusses 104, a projector 106, a support frame 108, a screen 110 held within the support frame 108 and a grey pigmented reflective board 112.

The projector 106 depends from a front upper cross-piece truss 104a of the box frame 102. The board 112 lies below the projector 106 at the base of the box frame 102. The screen 110, is inclined at approximately 45° to the horizontal and the front edge of the screen 110 is proximate the front upper cross-piece truss 104a of the box frame 102 and the rear edge of the screen is proximate a stage 109 that lies to the rear of the box frame 102.

The screen 110 is typically a polymeric foil, which can have a partially reflective coating upon a front face of the foil. The screen 110 is retained within the box frame 102 by means of tensioning straps 114 attached to the box frame 102, at the top and bottom edges of the screen 110. At a free end of each of the tensioning straps 114 there is pair of clamp jaws 116 which have respective openings 118, 120 passing there-through. The faces of the jaws 116 are optionally coated with an abrasive 121, such as sandpaper, in order to enhance the grip of the jaws 116 upon the screen 110.

Edges of the screen 110 are placed between the jaws 116 and a bolt 122 is placed through the openings 118, 120 and passes through the screen 110. A nut 124 is threaded onto the bolt 122 and tightened to hold the screen 110 between the jaws 116. The tensioning straps 114 pass through the trusses 104 and are tightened using a friction locking buckle arrangement 128.

Each of the tensioning straps 114 can be tightened or loosened individually so as to allow an even tension to be applied over the whole surface of the screen 110 thereby reducing, and ideally eliminating, the formation of wrinkles upon the screen 110 which reduce the quality of an image projected upon the screen 110.

The reflective board 112 lies below the projector 106 adjacent to a lower front cross-piece truss 104b of the box frame 102. The projector 106 is directed such that light emitted by the projector 106 strikes the reflective board 112. The board 112 is inclined so that the light emitted by the projector 106 is reflected upwards from the board 112 onto the screen 110. The use of a grey, or otherwise coloured board 112 reduces the milky hue associated with light from the projector where there is no image to be projected.

A fraction of the projected light striking the screen 110 is reflected from the front surface of the screen 110 where is can

be viewed by an audience. A presenter upon the stage **109** behind the screen **110** can also be viewed by the audience but does not interfere with the viewing of the image by the audience.

The board **112** is connected to a hinge arrangement **130** along a rear edge thereof. The hinge arrangement **130** allows the board **112** to be raised and lowered, typically by a hydraulic ramp **132** controlled by a computer **134**, in order to compensate for the 'keystone' effect. Alternatively, the board **112** can be raised and lowered by the person pulling upon a string, or an electric motor to drive the board up and down.

The raising and lowering of the board **112** also allows for the audience's perception of the positional depth upon the stage of an element of a projected image to be altered by varying the height of the element of the image upon the screen **110**. It is envisaged that the board **112** may comprise a number of individual sections each of which may be raised and lowered individually in order to allow the perceived depth of an individual element of an image to be varied independently of other elements of the image.

A non-reflective mask **136** in the shape of a prop **138**, in this example a rock, is placed upon the board **112**. The prop **138** is placed upon the stage **109**, typically behind the screen **110**. The mask **136** is placed such that the board **112** is obscured in a region corresponding to where the prop **138** is located with respect to the screen **110**. This arrangement of mask **136** and prop **138** results in an image, or part of the image, projected upon the screen **110** apparently disappearing as the image, or part of the image, passes over prop **138** and reappearing once the image, or part of the image has passed over the prop **138** as the mask **136** prevents light being reflected onto the region of the screen **110** corresponding to the location of the prop **138**. The mask **136** can be variable in size and shape, for example by means of a sliding panel that is moved into location and varied in size according to the size of the prop **138**. This also allows for the depth perception of props to be varied as their apparent effect upon variable depth image elements, as discussed hereinbefore, can be varied appropriately, for example a given size of rock will obscure proportionately more of a distant image than the same rock will of a near image.

A light source **140** is mounted upon the box frame **102** and illuminates the prop **138** in order to reduce the effect of any residual light reflected from the board **112** onto the prop.

Referring now to FIG. *2a*, an alternative projection arrangement **200**, suitable for use with the apparatus of FIGS. **1** and **2** with an additional truss, comprises the projector **106** depending from a truss **202** forward of the screen **110**, an inclined mirror **204** of variable inclination depending from a second truss **206** forward of projector **110**. The projector **106** projects an image on to the mirror **204** such that the image is projected on to the reflective board **112** and on to the screen **110**. The mirror **204** is typically arranged to be perpendicular to the board **112**, and in embodiments where the board **112** has a variable angle of inclination the mirror **204** will usually be arranged to track, synchronously, with any variation in the angle of inclination of the board **112**.

It will be appreciated that the term mirror is used herein to describe any reflective surface that reflects substantially all, typically in excess of 50% preferably in excess of 80%, light impinging upon it.

Referring now to FIG. **3**, a projection apparatus **300** is substantially similar to that of FIGS. **1** and **2** accordingly identical parts to those of FIGS. **1** and **2** are accorded similar reference numerals in the three hundred series.

A projection screen **306** resides in front of the screen **310** adjacent the lower front cross-piece truss **304b**. The projec-

tion screen **306** is typically a liquid crystal display (LCD) screen or a television screen. The projection screen **306** projects an image upwards onto the front surface of the screen **310**. The use of a projection screen **306** removes the 'keystone' effect associated with conventional projectors.

A mask **336** can be formed upon the screen by use of a computer **340** to control the projection screen **306** to black out the appropriate part of the projection screen **306** electronically. This removes the need for a physical mask to be produced. The computer **340** can be used to switch of areas of the projection screen **306** which do not contain part of an image to be projected, this reduces the milky white hue associated with such areas when using conventional projectors. Also, the use of a computer **340** to control the projection screen **306**, together with image sizing in relation to image movement allows an image to be readily scaled and positioned upon the projection screen **306** to enhance an audience's perception of depth and movement of a projected image using known image processing techniques. Alternatively, the projection screen **306**, or sections of the projection screen **306**, can be raised and lowered under the control of the computer **340** in order to enhance the audience's perception of depth of the projected image.

Referring now to FIG. **5**, a box truss framework **500** comprises a square upper truss work **502** and leg trusses **504**. In constructing the framework **500** the upper truss work **502** rests upon a number of jacks **506**. First sections **508** of the leg trusses **504** that extend at right angles to the upper truss work **502** are added at the corners of the upper truss work **502**. The height of the jacks **506** is increased to allow additional sections **510** of the leg trusses **504** to be added until the desired height of the box truss framework **500** is achieved.

A cross-piece truss **512** is fixed to two of the leg trusses **504** such that it horizontally spans the gap therebetween at a height close to, and typically slightly below, the level of a stage floor **514**. The leg trusses **504** spanned by the cross-piece truss **512** constitute the rear legs of the framework **500** and are located adjacent the front of the stage floor **514**.

A dust-free protective plastic sheet **515** is laid across the width of the stage floor **514** in front of the rear legs of the framework **500**. A roll of screen film **518** is removed from a protective cylindrical casing **520** and is unwound across the width of the stage floor **514**. The film **518** is placed upon the sheet **515** in order to prevent damage to the surface from dust particles or other sharp protrusions.

A lower edge **522** of the film **518** is placed between jaws **524a,b** of a retention member **526**, each jaw **524a,b** having opposed openings therethrough spaced at approximately 0.5 m intervals. Bolts **528** are placed through the openings, and through the film **518**, and secured in position using respective nuts. Ratchet straps **532** are attached to the retention member **526** adjacent alternate bolts **528**, having a spacing of approximately 1 m, and are then attached to the cross-piece truss **512**.

A second retention member **534** is attached to an upper edge **536** of the film **518** in a similar manner to how the retention member **526** is attached to the lower edge **522**. Ratchet straps **538** are attached to the second retention member **534**.

A rope **540** is tied to the second retention member **534** and is passed over the upper truss work **502** opposite the cross-piece truss **512**. The film raised into position using the rope **540** and the ratchet straps **538** are attached to the upper truss work **502**. Both sets of ratchet straps **532**, **538** are tightened individually until the screen film is tensioned such that the film **518** is flat and, ideally, free from wrinkles.

A projector **542** is depended from the upper truss work **502** and a pigmented reflective board **544** is placed between the

screen **518** and the front edge of the box truss framework **500** such that light emitted by the projector **542** is reflected from the board **544** onto the screen **518**. The screen **518** reflects at least part of the light from a front surface thereof away from the stage and into an auditorium to be viewed by and audience. 5

In order to prevent the audience observing the projection apparatus both side and front drapes **546** are used to screen the apparatus from the audience.

The invention claimed is:

1. An image projection apparatus, comprising:

a projector, a frame, a light source and an at least partially transparent screen;

the frame being arranged to retain the screen under tension, such that the tension of the screen can be varied at a plurality of positions along at least one edge of said screen such that the screen is substantially wrinkle free; the light source arranged to illuminate at least part of the apparatus;

the screen inclined at an angle with respect to a plane of emission of light from the projector and the screen having a front surface arranged such that light emitted from the projector is reflected therefrom; and

the projector being arranged to project an image such that light forming the image impinges upon the screen such that a virtual image is created from light reflected from the screen, the virtual image appearing to be located behind the screen, wherein the screen is foil and the frame comprises first and second retention members each arranged to sandwich an edge region of the screen therebetween, the first and second retention members comprising respective openings therethrough arranged to collocate with respective openings in the screen, wherein the openings are arranged to receive a fixing means so as to clamp the screen between the first and second retention members, and wherein at least one of the first and second retention members is attached to tensioning straps. 20

2. The apparatus of claim 1, wherein the screen is attached to the frame at the screen's upper edge, lower edge, or both. 40

3. The apparatus of claim 1, wherein the tensioning straps are attached to a truss arrangement or a fixed mounting point located in a permanent structure such as a wall, floor or ceiling and are adjustable such that the tension of the screen within the truss arrangement can be varied about the periphery of the screen. 45

4. The apparatus of claim 3, wherein the retention members are substantially parallel to truss members comprising the truss arrangements.

5. The apparatus of claim 1, wherein the screen is inclined at approximately 45° to the plane of emission of light from the projector. 50

6. The apparatus of claim 1, wherein the light source is located to the rear of the screen, along a top edge of the frame, along either side of a stage, or some combination thereof. 55

7. An image projection apparatus, comprising:

a projector, a frame or fixed mounting points, and an at least partially transparent screen;

the frame or fixed mounting points being arranged to retain the screen under tension, such that the screen is inclined at an angle with respect to a plane of emission of light from the projector;

the screen having a front surface arranged such that light emitted from the projector is reflected therefrom; and

the projector being arranged to project an image such that light forming the image impinges upon the screen such that a virtual image is created from light reflected from 65

the screen, the virtual image appearing to be located behind the screen, and wherein the frame comprises first and second retention members arranged to sandwich an edge region of the screen therebetween, and wherein a plurality of fixing means pass through the first retention member and through the screen and clamp the screen between the first and second retention members, and optionally locking means is provided adapted to lock the fixing means;

wherein the screen is a polymeric transparent foil that is held taught and substantially wrinkle-free by the retention members, the retention members having generally parallel faces which clamp an edge region of the foil between them, and wherein individually variable foil tensioning mechanisms are provided at spaced apart locations around the periphery of the foil to enable the foil to have tensioning force independently varied at the said spaced apart locations around the periphery of the foil, and wherein the first and second retention members are connected to one or more flexible tensioning means, which extend from the frame or fixed mounting points to the foil-gripping members, the foil, flexible tensioning means and the frame or fixed mounting points lying in a common inclined plane, with the tension on the foil being applied in the plane of the flexible tensioning means, and the foil, the tensioning mechanisms comprising straps and ratchet strap tensioners, or straps and a friction-locking buckle arrangement.

8. The apparatus according to claim 7, wherein respective locking means are provided for the fixing means. 30

9. The apparatus according to claim 8, wherein the locking means is provided in the form of nuts, to lock the fixing means in position, the fixing means extending through the retention members and the screen.

10. The apparatus according to claim 7, wherein the first and second retention members comprise a plurality of respective openings, with the fixing means extending through the openings.

11. The apparatus according to claim 7, wherein an abrasive surface is provided on at least one of the retention members to increase the grip between the retention member and the screen, thereby reducing the likelihood of the screen slipping when held by the retention member.

12. The apparatus according to claim 11, wherein the abrasive surface comprises sandpaper.

13. The apparatus according to claim 7, wherein the screen is a foil.

14. An image projection apparatus, comprising:

a projector, a frame or fixed mounting points, and an at least partially transparent screen;

the frame or fixed mounting points being arranged to retain the screen under tension, such that the screen is inclined at an angle with respect to a plane of emission of light from the projector;

the screen having a front surface arranged such that light emitted from the projector is reflected therefrom; and

the projector being arranged to project an image such that light forming the image impinges upon the screen such that a virtual image is created from light reflected from the screen, the virtual image appearing to be located behind the screen, and wherein the frame comprises first and second retention members arranged to sandwich an edge region of the screen therebetween, the first and second retention members being connected to one or more flexible tensioning means, which extend from the frame or fixed mounting points, the foil, flexible tensioning means and the frame or fixed mounting points lying

11

in a common inclined plane, with the tension on the foil being applied in the plane of the flexible tensioning means and the foil, and wherein a plurality of fixing means pass through the first retention member and through the screen and clamp the screen between the first and second retention members, optionally locking means is provided adapted to lock the fixing means, and the first and second retention members comprise respective openings therethrough arranged to collocate with openings in respective jaws of clamping members attached to tensioning straps.

15. The apparatus according to claim **14**, wherein the screen comprises a partially reflective layer upon the front surface and is inclined at approximately 45° to the plane of emission of light from the projector.

12

16. The apparatus according to claim **14**, wherein the screen is attached to the frame at the screen's upper edge, lower edge, or both.

17. The apparatus according to claim **14**, wherein the tensioning straps are attached to a truss arrangement or a fixed mounting point located in a permanent structure such as a wall, floor or ceiling and are adjustable such that the tension of the screen within the truss arrangement can be varied about the periphery of the screen.

18. The apparatus according to claim **17**, wherein the retention members are substantially parallel to truss members comprising the truss arrangement.

* * * * *