



US007522211B2

(12) **United States Patent**
Lee et al.

(10) **Patent No.:** **US 7,522,211 B2**
(45) **Date of Patent:** **Apr. 21, 2009**

(54) **STUDIO LIGHT**

(75) Inventors: **Kian Shin Lee**, Penang (MY); **Janet Bee Yin Chua**, Perak (MY); **Yue Hoong Lau**, Penang (MY); **Teoh Teh Seah**, Loveland, CO (US); **Joon Chok Lee**, Sarawak (MY)

(73) Assignee: **Avago Technologies ECBU IP (Singapore) Pte. Ltd.**, Singapore (SG)

(*) Notice: Subject to any disclaimer, the term of this patent is extended or adjusted under 35 U.S.C. 154(b) by 359 days.

5,909,245 A	6/1999	Aoki et al.	
6,277,301 B1	8/2001	Hohn et al.	
6,344,641 B1 *	2/2002	Blalock et al.	250/205
6,379,022 B1	4/2002	Amerson et al.	
6,448,550 B1 *	9/2002	Nishimura	250/226
6,501,091 B1	12/2002	Bawendi et al.	
6,636,003 B2 *	10/2003	Rahm et al.	315/179
6,664,556 B2	12/2003	Doberenz	
6,781,329 B2 *	8/2004	Mueller et al.	315/297
6,803,719 B1	10/2004	Miller et al.	
6,864,749 B2	3/2005	Seetharaman et al.	

(21) Appl. No.: **11/055,739**

(Continued)

(22) Filed: **Feb. 10, 2005**

FOREIGN PATENT DOCUMENTS

(65) **Prior Publication Data**

DE 100 31 303 A1 1/2002

US 2006/0176692 A1 Aug. 10, 2006

(51) **Int. Cl.**

H04N 5/222 (2006.01)

(Continued)

(52) **U.S. Cl.** **348/370**; 348/371; 348/227.1; 315/159; 315/307; 315/362; 362/227; 362/240; 362/231

OTHER PUBLICATIONS

U.K. Patent Office Search Report dated Jun. 1, 2006 issued by U.K.

(58) **Field of Classification Search** 348/370, 348/371, 223.1, 224.1, 227.1; 362/240, 227, 362/231, 285, 293, 295, 800; 315/156-159, 315/291, 307, 360, 362; 250/226, 211, 205, 250/216, 214 R

(Continued)

Primary Examiner—Haissa Philogene

See application file for complete search history.

(57) **ABSTRACT**

(56) **References Cited**

U.S. PATENT DOCUMENTS

5,016,046 A	5/1991	Nishiyama	
5,067,049 A *	11/1991	Milaire	362/18
5,117,118 A	5/1992	Fukuyama	
5,477,326 A	12/1995	Dosmann	
5,722,755 A	3/1998	Slape	
5,758,942 A	6/1998	Fogal et al.	
5,815,204 A	9/1998	Abe et al.	
5,895,128 A	4/1999	Kishimoto et al.	

A studio light having first and second light output regimes, and adjustable color temperature. The color temperatures of the first and second light output regimes may be different. The light module includes one or more emitters of light of at least two different colors. An external signal causes the light module to switch from a first light output regime to a second, higher intensity light output regime, and back to the first light output regime.

15 Claims, 1 Drawing Sheet

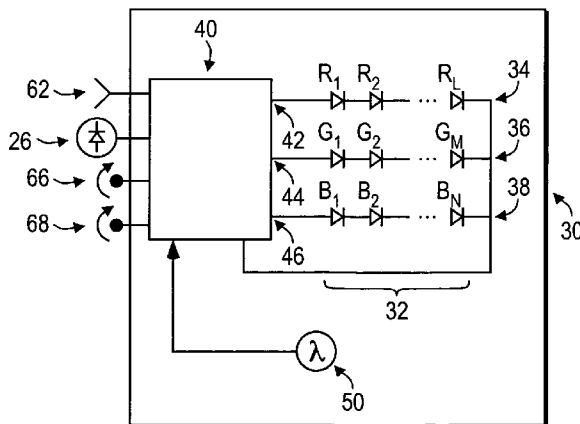

U.S. PATENT DOCUMENTS

6,894,266 B2 5/2005 Richard et al.
 6,909,377 B2 6/2005 Eberl
 7,005,667 B2 2/2006 Chen et al.
 7,102,152 B2 9/2006 Chua et al.
 7,106,378 B2* 9/2006 Kawakami 348/371
 7,178,941 B2* 2/2007 Roberge et al. 362/225
 2002/0191102 A1 12/2002 Yuyama et al.
 2003/0052992 A1 3/2003 Nakata
 2003/0123873 A1 7/2003 Okubo
 2003/0127659 A1 7/2003 Bawendi et al.
 2003/0127660 A1 7/2003 Bawendi et al.
 2003/0180037 A1 9/2003 Sommers
 2003/0216151 A1 11/2003 Kitano et al.
 2004/0245912 A1 12/2004 Thurk et al.
 2005/0134723 A1* 6/2005 Lee et al. 348/370
 2005/0135079 A1* 6/2005 Yin Chua et al. 362/12
 2005/0199784 A1 9/2005 Jaffar et al.
 2006/0002110 A1* 1/2006 Dowling et al. 362/252

FOREIGN PATENT DOCUMENTS

DE 10055767 A1 8/2002
 DE 102 61 365 A1 7/2004
 DE 102 61 428 A1 7/2004
 EP 1 160 883 A2 12/2001

EP 1 369 935 A1 12/2003
 EP 1176849 A2 9/2004
 GB 2253718 A 9/1992
 JP 2003-7103 A 1/2003
 JP 2003-66519 A 3/2003
 JP 2003-215675 A 7/2003
 JP 2005011628 A 1/2005
 JP 2006025167 A 1/2006
 WO WO 2004/060024 A 7/2004

OTHER PUBLICATIONS

German Office Action dated Mar. 28, 2006 involving German Application No. 10 2005 045 106.3-33.
 English translation of German Office Action dated Mar. 28, 2006 involving German Application No. 10 2005 045 106.3-33 (co-pending application).
 German Office Action dated Jan. 31, 2007 involving counterpart German Application No. 10 2005 058 877.8-42.
 English translation of German Office Action dated Jan. 31, 2007 involving counterpart German Application No. 10 2005 058 877.8-42.
 UK Search Report dated Feb. 16, 2005 involving UK Application No. GB0427259.7 (co-pending application).
 Evident Technologies, Nanomaterials Catalog v5.0, Nanomaterial Products (Aug. 2004), pp. 1 - 12.

* cited by examiner

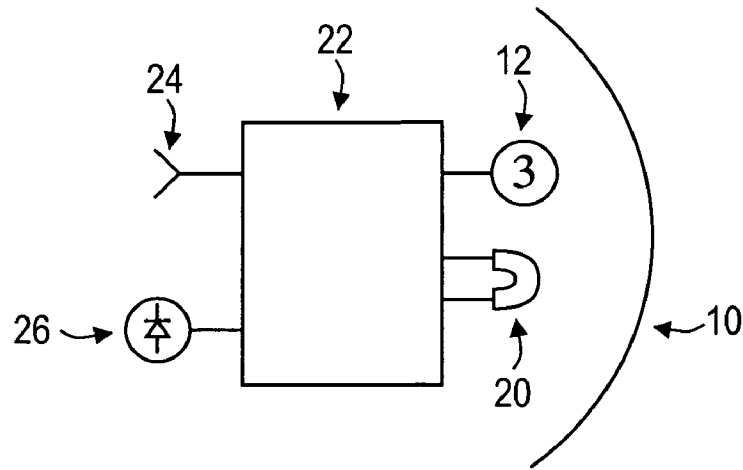

Figure 1 (Prior Art)

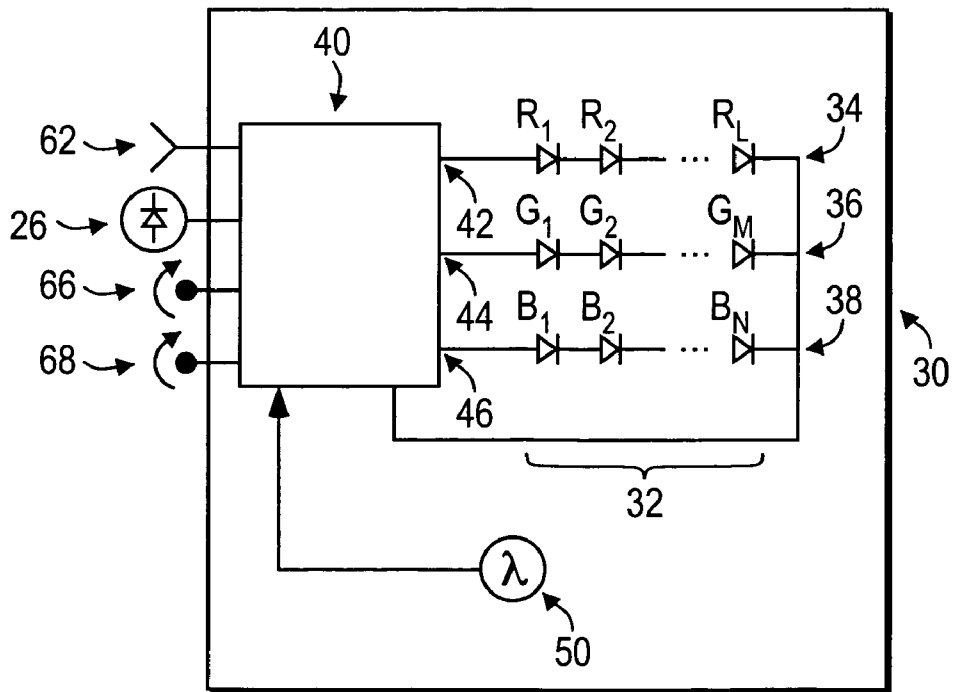

Figure 2

1

STUDIO LIGHTCROSS REFERENCE TO RELATED
APPLICATIONS

The present application is related to co-pending and commonly assigned U.S. patent application Ser. No. 10/742,310 filed Dec. 19, 2003, entitled "Flash Lighting for Image Acquisition," and to co-pending and commonly assigned U.S. patent application Ser. No. 10/799,126 filed Mar. 11, 2004, entitled "Light to PWM Converter," the disclosures of which are incorporated herein by reference.

TECHNICAL FIELD

Embodiments in accordance with the invention are related to lighting used in photography.

BACKGROUND

Lighting plays a vital role in photography, particularly in studio photography. For settings such as portraiture, it is common to use a number of studio lights to illuminate the subject and the backdrop. For a particular setting, the lighting may include a main light, providing the main lighting on the subject, one or more side or fill lights, filling in along the sides of the subject, and a back light illuminating the backdrop.

Commonly used studio lights comprise an incandescent lamp which provides steady illumination at a first, low intensity, and a flashtube, typically filled with Xenon gas or a combination of gases, which provides flash illumination at a second, much higher intensity but for a very brief period. The incandescent lamp in the studio light allows the photographer to position and adjust the lighting, while the flashtube provides high intensity illumination for recording the image. The flashtube in the studio light may be triggered from an electrical signal such as from a wire connection to a camera or other studio light, a wireless connection using radio frequency (RF) transmitters and receivers, or may be triggered in "slave" fashion by a photosensor on the studio light detecting another flash.

Such a system of studio lights allows the photographer to set the subject, position the studio lights, and then record images.

Proper color balance, or color temperature of lighting sources is very important in color photography. Flash sources commonly have equivalent color temperatures similar to daylight, on the order of 5200-5500 degrees Kelvin (K). Commonly used incandescent (tungsten) sources have color temperatures on the order of 3200K.

In the studio setting, the photographer must perform setup using incandescent illumination, while recording images using flash illumination; the color balances of the two are quite distinct. In some settings, such as those outside the studio, the photographer may have to deal with situations with strong ambient light from tungsten or fluorescent sources, or from sunlight or other strong illumination filtered through or reflected off colored objects. In these situations, the photographer may use filters to try and correct the illumination to provide a balanced image.

2

Based on the fixed spectra of presently available flashes and the limitations of filters used to modify spectral content of available light, there is a need for a studio light with adjustable color temperature.

SUMMARY OF THE INVENTION

A solid-state studio lighting system according to the present invention provides light from a solid-state source at a first intensity and equivalent color temperature, switching to a second, higher intensity for a short duration. The equivalent color temperature of the second, higher intensity illumination may be different from the first color temperature. The solid state-source comprises emitters in a plurality of colors.

BRIEF DESCRIPTION OF THE DRAWINGS

FIG. 1 shows a block diagram of a studio light known to the art, and

FIG. 2 shows an exemplary studio light according to an embodiment of the present invention.

DETAILED DESCRIPTION OF THE
EMBODIMENTS

FIG. 1 shows a block diagram of a studio light as known to the art. Reflector **10** reflects and diffuses light from incandescent source **12**, and flash source **20**. Flash electronics **22** provide the high voltage necessary to operate flash source **20**, and include synchronization terminal **24**, and flash sensor **26**, typically a photodiode. Flash source **20** is typically a xenon flash lamp. Flash electronics **22** may provide selectable flash intensities, but the effective color temperature of flash source **20** remains constant, defined by the chemical composition of the gas in flash source **20**.

During operation, incandescent source **12** provides illumination for adjusting and focusing lights. During image capture, flash source **20** is triggered through synchronization terminal **24** or flash sensor **26**, and flash illumination is provided at a much higher intensity for a brief period, and with a color temperature set by the gas composition of the flash tube. The color temperature of the flash illumination may be changed with filters, but such filters are expensive, and change over time as they are repeatedly blasted by the flash source **20**.

FIG. 2 shows a block diagram of an studio light **30** according to an embodiment of the present invention. Studio light **30** includes light module **32** with a set of emitters of light of at least two different colors. In the embodiment of FIG. 2, the emitters are indicated as R_1 - R_L **34**, G_1 - G_M **36**, and B_1 - B_N **38**. The subscripts L, M, N are integers that represent the number of red emitters, green emitters and blue emitters, respectively. The number of emitters of each color will be determined by the light output needed and the light output available from each individual emitter. While a series connection is shown, the emitters may be driven in parallel, or individually.

In the embodiment shown, red, green and blue light emitting diodes are used, although emitters of other colors are alternatively used to provide a sufficiently wide spectral content adjustment range. Driver **40** provides drive signals S_R **42**, S_G **44**, and S_B **46** to these different color emitters R_1 - R_L , G_1 - G_M , B_1 - B_N , respectively. By varying the drive signals corresponding to the different color emitters in the series, the spectral content of flash light provided by the light module **32**, which is a mixture of the light provided by the different color emitters, can be correspondingly varied.

Color sensors **50** sense the color of the light emitted by light module **32**. Typically, sensors **50** are CMOS detectors, photodiodes or other transducers that convert received light from light module **32** to electrical signals that can be processed by driver **40** to produce the desired color temperature. The color temperature required will be determined by the camera or imaging device used with studio light **30**. Daylight imaging is balanced for bluish light having a color temperature of 5500 Kelvin for example. Alternatively, imagers such as film cameras using tungsten film are balanced for orange or warmer light having a color temperature of 3200 Kelvin for example.

Driver **40** has synchronization terminal **62**, and optionally flash sensor **64**, typically a photodiode. Also provided is first color temperature adjustment **66**, and second color temperature adjustment **68**. Optional adjustments may be provided for a first and second intensity level, or these intensity levels may be preset by driver **40**.

In operation, driver **40** provides a first, low level of illumination at a first color temperature selected by first color temperature adjustment **66** by providing drive signals **42**, **44**, **46** to light module **32**. In response to a flash signal, through synchronization terminal **62** or flash sensor **64**, driver **40** switches light module **32** to a second, higher level of flash illumination selected at second color temperature adjustment **68** by providing drive signals **42**, **44**, **46** to light module **32**. This second, higher level of flash illumination is provided for a brief period of time, typically on the order of milliseconds, after which driver **40** switches light module **32** back to the first, low level of illumination.

The adjustable spectral provided by light module **30** can provide color balancing to help to neutralize ambient lighting, or otherwise accommodate for an undesired color content or color temperature of the ambient light. The spectral content of the flash illumination provided by light module **30** can also be adjusted to achieve a desired photographic effect. For example, providing flash illumination that is cooler when the photographic is a dark-skinned human generally results in an acquired image wherein the skin appears to be lighter, whereas providing a warmer light to such a photographic subject results in an acquired image wherein the skin appears to be a richer tan color. In addition to these particular examples, a variety of image characteristics and effects can be achieved via adjustments of the spectral content of the flash illumination provided by color temperature adjustment **68**.

In one embodiment, the emitters of the light module **32** are solid state light sources such as laser diodes or LEDs (light emitting diodes). In addition to using normal LEDs, phosphor-broadened LEDs using phosphor coatings known to the art which are excited by an LED may be used to produce wider spectral output. However, the set of emitters includes any other light sources of two or more different colors, or any suitable light source that has a spectral content that is adjustable. The emitters of different colored light in the light module **32** are independently accessible. In one example, the series of emitters R_1 - R_L , G_1 - G_M , B_1 - B_N includes an array of one or more red emitters R_1 - R_L , such as red LEDs, one or more green emitters G_1 - G_M , such as green LEDs, and one or more blue emitters B_1 - B_N , such as blue LEDs. Red, green and blue are readily available LED colors and when the output light from these LEDs is mixed, the emitters R_1 - R_L , G_1 - G_M , B_1 - B_N provide adequate coverage of the color space for the resultant flash illumination.

The number and arrangement of emitters is determined to a great extent by the light output of the emitters included in the light module **32** and the needed intensity of the flash illumination. The emitters of each color may be intermixed, or may

be grouped in designated color sections. Independent accessibility of the different color emitters R_1 - R_L , G_1 - G_M , B_1 - B_N enables the relative intensities of the different color emitters to be independently varied, which results in the spectral content or color temperature of the flash illumination provided by the light module **32** being varied.

The relative intensities of the light provided by each of the different color emitters is varied via corresponding variations in the drive signals **42**, **44**, **46** provided to each of the different color emitters R_1 - R_L , G_1 - G_M , B_1 - B_N , respectively. In the example where the red emitters R_1 - R_L include one or more red LEDs, the green emitters G_1 - G_M include one or more green LEDs and the blue emitters B_1 - B_N include one or more blue LEDs, the drive signals **42**, **44**, **46** are typically currents provided to the LEDs and the relative intensities of the colored light output of the emitters R_1 - R_L , G_1 - G_M , B_1 - B_N is varied according to relative magnitudes of the currents that are supplied to activate the different color LEDs. For example, to provide flash illumination with increased blue intensity, current provided to the blue LEDs is increased relative to the current provided to the green LEDs and the current provided to the red LEDs. Similarly, flash illumination having different spectral content is provided by relative variations of the currents that are provided to the different color LEDs. To provide the drive signals **42**, **44**, **46**, in this example, driver **40** varies the current to different color emitters in the light module **32**. Driver **40** can include any other circuit, element or system suitable for modulating the relative intensities of the light provided by each of the different color emitters R_1 - R_L , G_1 - G_M , B_1 - B_N . An example of a method and apparatus for controlling spectral content of different color emitters is provided in U.S. Pat. No. 6,448,550 B1 to Nishimura, and is hereby incorporated by reference. However, any other drive signals **42**, **44**, **46** or drive schemes suitable for varying the spectral content of the illumination provided by the light module **32** are alternatively included.

In the example where the different color emitters each include an array of light sources, such as LEDs, the relative intensities of the different color emitters are alternatively adjustable by corresponding adjustments in the number of light sources within the array that are activated. For example, to provide flash illumination with decreased blue intensity, current is provided to fewer blue LEDs than the green LEDs or red LEDs, and so on. Thus, in this example the spectral content of the flash illumination can be adjusted in discrete steps by using switches other suitable circuitry to vary the number of individual emitters of each color that are activated by the drive signals.

Typically, emitters R_1 - R_L , G_1 - G_M , B_1 - B_N included in the light module **32** have integrated lenses that establish the spatial distribution of illumination provided by light module **32**. However, reflectors, lenses or other optical elements are optionally included externally to the emitters R_1 - R_L , G_1 - G_M , B_1 - B_N in the light module **32** to control the spatial distribution of the illumination produced.

While the embodiments of the present invention have been illustrated in detail, it should be apparent that modifications and adaptations to these embodiments may occur to one skilled in the art without departing from the scope of the present invention as set forth in the following claims.

The invention claimed is:

1. A photographic studio light module, comprising: a plurality of light emitters having at least two different colors;

5

- a driver circuit operably connected to the plurality of light emitters and configured to provide corresponding driving signals to each or groups of the plurality of light emitters;
- a plurality of light sensors configured to sense a color temperature and an intensity of light emitted by the plurality of light emitters and provide electrical signals representative thereof to the driver circuit, the driver circuit further being configured to receive and process the electrical signals to determine the color temperature and intensity;
- a flash synchronization circuit configured to receive an external flash input signal;
- wherein the light module is configured to operate selectively between a first low-level illumination mode providing emitted light of a first color temperature and a first intensity and a second flash mode providing emitted light of a second color temperature, the light module further being configured to operate in the first low-level illumination mode until the external input flash signal is provided thereto whereupon the light module switches to the flash mode and provides a flash output illumination signal, the light module still further being configured to return to the low-level illumination mode after the output flash illumination signal has been provided thereby.
2. The photographic studio light module of claim 1, wherein the first color temperature is different from the second color temperature.
3. The photographic studio light module of claim 1, wherein the first color temperature is substantially the same as the second color temperature.
4. The photographic studio light module of claim 1, wherein the first intensity is less than the second intensity.
5. The photographic studio light module of claim 1, wherein the first and second color temperatures are adjustable.
6. The photographic studio light module of claim 1, wherein the first and second light intensities are adjustable.

6

7. The photographic studio light module of claim 1, wherein the external flash input signal is selected from the group consisting of an electrical signal, a wireless signal and a light signal.
8. The photographic studio light module of claim 1, wherein the plurality of light emitters further comprises light emitters of at least three different colors.
9. The photographic studio light module of claim 1, wherein the plurality of light emitters further comprises at least one red solid state light emitter, at least one green solid state light emitter and at least one blue solid state light emitter.
10. The photographic studio light module of claim 1, wherein the plurality of light emitters further comprises an array of at least one red solid state light emitter, an array of at least one green solid state light emitter and an array of at least one blue solid state light emitter.
11. The photographic studio light module of claim 1, wherein the plurality of light emitters further comprises at least one phosphor-broadened solid state LED.
12. The photographic studio light module of claim 1, wherein the driver circuit is configured to drive the plurality of light emitters at least one of serially, in parallel or individually.
13. The photographic studio light module of claim 1, wherein the first and second color temperatures of the light emitted by individual ones or arrays of the plurality of light emitters is adjustable in accordance with the driving signals provided thereto.
14. The photographic studio light module of claim 1, wherein the first and second intensities of the light emitted by individual ones or arrays of the plurality of light emitters is adjustable in accordance with the driving signals provided thereto.
15. The photographic studio light module of claim 1, further comprising at least one of a reflector, a lens and an optical element configured to control the spatial distribution of illumination provided by the light module.

* * * * *