



US007497590B2

(12) **United States Patent**
Rains, Jr. et al.

(10) **Patent No.:** **US 7,497,590 B2**
(45) **Date of Patent:** **Mar. 3, 2009**

(54) **PRECISE REPEATABLE SETTING OF COLOR CHARACTERISTICS FOR LIGHTING APPLICATIONS**

(58) **Field of Classification Search** 250/228;
315/291
See application file for complete search history.

(75) Inventors: **Jack C. Rains, Jr.**, Oak Hill, VA (US);
Matthew Brown, Falls Church, VA (US);
Christopher Bates, Sioux Falls, SD (US)

(56) **References Cited**

U.S. PATENT DOCUMENTS

4,677,533 A 6/1987 McDermott et al.

(Continued)

FOREIGN PATENT DOCUMENTS

DE 200 07 134 9/2000

(Continued)

OTHER PUBLICATIONS

LSI unveils the LumeLex™ at ARC06, Lighting Services Inc., Product News, printed from http://www.lightingservicesinc.com/press_article.asp?pressID=103 on Feb. 16, 2006.

(Continued)

Primary Examiner—Anabel M Ton
(74) *Attorney, Agent, or Firm*—McDermott Will & Emery LLP

(73) Assignee: **Advanced Optical Technologies, LLC**, Herndon, VA (US)

(*) Notice: Subject to any disclaimer, the term of this patent is extended or adjusted under 35 U.S.C. 154(b) by 301 days.

(21) Appl. No.: **10/555,094**

(22) PCT Filed: **Apr. 26, 2005**

(86) PCT No.: **PCT/US2005/014107**

§ 371 (c)(1),
(2), (4) Date: **Nov. 2, 2005**

(87) PCT Pub. No.: **WO2005/105381**

PCT Pub. Date: **Nov. 10, 2005**

(65) **Prior Publication Data**

US 2006/0203483 A1 Sep. 14, 2006

Related U.S. Application Data

(63) Continuation-in-part of application No. 10/832,464, filed on Apr. 27, 2004, now Pat. No. 6,995,355.

(51) **Int. Cl.**
F21V 9/00 (2006.01)

(52) **U.S. Cl.** **362/231; 362/230; 362/227; 250/228**

(57) **ABSTRACT**

A desired color of illumination of a subject is achieved by determining settings for color inputs and applying those settings to one or more systems that generate and mix colors of light, so as to provide combined light of the desired character. In the examples of appropriate systems, an optical integrating cavity diffusely reflects light of three or more colors, and combined light emerging from an aperture of the cavity illuminates the subject. System settings for amounts of the different colors of the input lights are easily recorded for reuse or use in other systems.

17 Claims, 12 Drawing Sheets

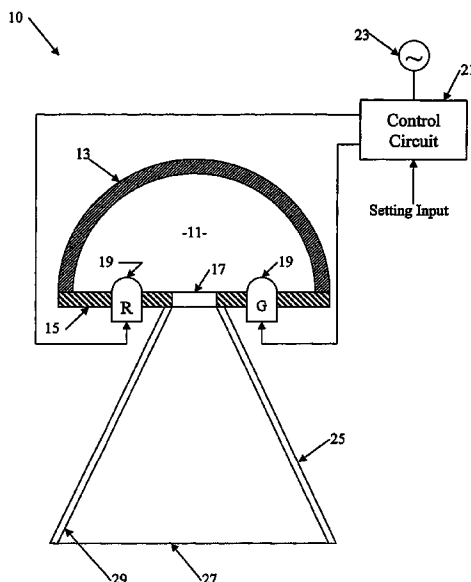

U.S. PATENT DOCUMENTS						
4,962,687	A	10/1990	Belliveau et al.	6,577,080	B2 6/2003	Lys et al.
4,992,704	A	2/1991	Stinson	6,601,974	B1 8/2003	Hewlett et al.
5,241,459	A	8/1993	Kaplan et al.	6,607,794	B1 8/2003	Wilson et al.
5,365,084	A	11/1994	Cochran et al.	6,608,453	B2 8/2003	Morgan et al.
5,400,228	A	3/1995	Kao	6,624,597	B2 9/2003	Dowling et al.
5,420,482	A	5/1995	Phares	6,626,558	B2 9/2003	Momot et al.
5,453,849	A	9/1995	Copenhaver et al.	6,636,003	B2 10/2003	Rahm et al.
5,471,052	A	11/1995	Ryczek	6,659,622	B2 12/2003	Katogi et al.
5,548,493	A	8/1996	Young	6,676,282	B2 1/2004	Begemann et al.
5,608,213	A	3/1997	Pinkus et al.	6,686,691	B1 2/2004	Mueller et al.
5,650,843	A	7/1997	Moberg et al.	6,692,136	B2 2/2004	Marshall et al.
5,705,804	A	1/1998	Ramer et al.	6,700,112	B2 3/2004	Brown
5,733,028	A	3/1998	Ramer et al.	6,717,376	B2 4/2004	Lys et al.
5,752,766	A	5/1998	Bailey et al.	6,720,745	B2 4/2004	Lys et al.
5,757,111	A	5/1998	Sato	6,744,223	B2 6/2004	Laflamme et al.
5,803,592	A	9/1998	Lawson	6,744,693	B2 6/2004	Brockmann et al.
5,838,247	A	11/1998	Bladowski	6,759,814	B2 7/2004	Vogel et al.
5,877,490	A	3/1999	Ramer et al.	6,774,584	B2 8/2004	Lys et al.
5,877,849	A	3/1999	Ramer et al.	6,777,891	B2 8/2004	Lys et al.
5,886,351	A	3/1999	Ramer et al.	6,781,329	B2 8/2004	Mueller et al.
5,899,557	A	5/1999	McDermott	6,788,011	B2 9/2004	Mueller et al.
5,914,487	A	6/1999	Ramer et al.	6,793,374	B2 9/2004	Begemann
5,966,393	A	10/1999	Hide et al.	6,801,003	B2 10/2004	Schanberger et al.
5,967,652	A	10/1999	Ramer et al.	6,806,659	B1 10/2004	Mueller et al.
6,007,209	A	12/1999	Pelka	6,836,083	B2 12/2004	Mukai
6,007,225	A	12/1999	Ramer et al.	6,840,652	B1 1/2005	Hymer
6,016,038	A *	1/2000	Mueller et al. 315/291	6,854,857	B2 2/2005	Hara et al.
6,043,873	A	3/2000	Ramer et al.	6,869,204	B2 3/2005	Morgan et al.
6,064,061	A	5/2000	Ramer et al.	6,869,206	B2 3/2005	Zimmerman et al.
6,084,250	A	7/2000	Justel et al.	6,883,929	B2 4/2005	Dowling
6,088,091	A	7/2000	Ramer et al.	6,888,322	B2 5/2005	Dowling et al.
6,127,783	A	10/2000	Pashley et al.	6,897,624	B2 5/2005	Lys et al.
6,139,166	A	10/2000	Marshall et al.	6,936,978	B2 8/2005	Morgan et al.
6,149,283	A	11/2000	Conway et al.	6,960,872	B2 11/2005	Beeson et al.
6,150,774	A	11/2000	Mueller et al.	6,963,175	B2 11/2005	Archenhold et al.
6,166,496	A	12/2000	Lys et al.	6,965,205	B2 11/2005	Piepgras et al.
6,183,086	B1	2/2001	Neubert	6,967,448	B2 11/2005	Morgan et al.
6,184,628	B1	2/2001	Ruthenberg	6,969,954	B2 11/2005	Lys
6,200,002	B1	3/2001	Marshall et al.	6,975,079	B2 12/2005	Lys et al.
6,211,626	B1	4/2001	Lys et al.	6,995,355	B2 * 2/2006	Rains et al. 250/228
6,219,140	B1	4/2001	Kaplan	7,012,382	B2 3/2006	Cheang et al.
6,222,172	B1	4/2001	Fossum et al.	7,014,336	B1 3/2006	Ducharme et al.
6,222,623	B1	4/2001	Wetherell	7,025,464	B2 4/2006	Beeson et al.
6,234,648	B1	5/2001	Borner et al.	7,031,920	B2 4/2006	Dowling et al.
6,238,077	B1	5/2001	Ramer et al.	7,038,398	B1 5/2006	Lys et al.
6,257,737	B1	7/2001	Marshall et al.	7,038,399	B2 5/2006	Lys et al.
6,266,136	B1	7/2001	Ramer et al.	7,040,774	B2 5/2006	Beeson et al.
6,273,589	B1	8/2001	Weber et al.	7,042,172	B2 5/2006	Dowling et al.
6,280,054	B1	8/2001	Cassarly et al.	7,048,385	B2 5/2006	Beeson et al.
6,286,979	B1	9/2001	Ramer et al.	7,064,498	B2 6/2006	Dowling et al.
6,292,901	B1	9/2001	Lys et al.	7,108,413	B2 9/2006	Kwong et al.
6,299,329	B1	10/2001	Mui et al.	7,144,131	B2 12/2006	Rains
6,334,700	B2	1/2002	Ramer et al.	7,145,125	B2 12/2006	May et al.
6,340,868	B1	1/2002	Lys et al.	7,148,470	B2 12/2006	Rains, Jr. et al.
6,342,695	B1	1/2002	Ramer et al.	7,157,694	B2 1/2007	May et al.
6,357,889	B1	3/2002	Duggal et al.	7,159,986	B2 1/2007	Bremer et al.
6,357,893	B1	3/2002	Belliveau	7,220,039	B2 5/2007	Ahn et al.
6,361,192	B1	3/2002	Fussell et al.	7,374,311	B2 5/2008	Rains, Jr. et al.
6,422,718	B1	7/2002	Anderson et al.	2002/0064043	A1 5/2002	Ariga et al.
6,441,558	B1	8/2002	Muthu et al.	2002/0145708	A1 10/2002	Childers et al.
6,442,718	B1	8/2002	Tran et al.	2002/0191416	A1 12/2002	Wesson
6,459,919	B1	10/2002	Lys et al.	2003/0034985	A1 2/2003	Riddle et al.
6,488,389	B2	12/2002	Cassarly et al.	2003/0063462	A1 4/2003	Shimizu et al.
6,523,977	B2	2/2003	Chuang et al.	2003/0076056	A1 4/2003	Schuurmans
6,525,668	B1	2/2003	Petrick	2003/0117796	A1 6/2003	Voser
6,527,411	B1	3/2003	Sayers	2003/0193816	A1 10/2003	Rahn
6,528,954	B1	3/2003	Lys et al.	2003/0197113	A1 10/2003	Pitigoi-Aron et al.
6,533,429	B2	3/2003	Yoneda	2004/0012027	A1 1/2004	Keller et al.
6,536,914	B2	3/2003	Hoelen et al.	2004/0095779	A1 5/2004	Schottland et al.
6,547,416	B2	4/2003	Pashley et al.	2004/0105264	A1 6/2004	Spero
6,548,967	B1	4/2003	Dowling et al.	2004/0151008	A1 8/2004	Artsyukhovich et al.
				2004/0156199	A1 8/2004	Rivas et al.
				2004/0160199	A1 8/2004	Morgan et al.

2004/0188594 A1 9/2004 Brown et al.
 2004/0232812 A1 11/2004 Beeson et al.
 2004/0233655 A1 11/2004 Zimmerman et al.
 2004/0233664 A1 11/2004 Beeson et al.
 2005/0040774 A1 2/2005 Mueller et al.
 2005/0062446 A1 3/2005 Ashdown
 2005/0063063 A1 3/2005 Ashdown
 2005/0156103 A1 7/2005 May et al.
 2005/0161586 A1 7/2005 Rains et al.
 2006/0001381 A1 1/2006 Robinson et al.
 2006/0028156 A1 2/2006 Jungwirth
 2006/0072314 A1 4/2006 Rains

FOREIGN PATENT DOCUMENTS

EP 1 176 849 A2 1/2002
 JP 08-180978 7/1996
 JP 2000-321126 11/2000
 WO WO 00/19141 4/2000
 WO WO 02/076150 A1 9/2002
 WO WO 03/069219 A1 8/2003
 WO WO/2004/011846 2/2004

OTHER PUBLICATIONS

"TIR Systems' Partner Lighting Services Inc. Unveils First Product Based on Lixel™ Technology at ARC06 in London", Press Release, Feb. 13, 2006.
 Brent York, "Bridging the Gap for LEDs in the Architectural and Lighting Markets", TIR Systems Ltd., Blue 2005, May 16-19.
 Leonard Hordyk, Commercializing Innovative SSL Technology: From the Laboratory to Lighting, TIR Systems Ltd., Strategies in Light, Feb. 16, 2006.
 Grant Harlow, "Workshop 4: LED Technology, Bridging the Gap: From LEDs to Lighting", TIR Systems Ltd., LightFair, Apr. 11, 2005.
 Rohwer, L. et al. "Development of Phosphors for LEDs" The Electrochemical Society, *Interface*, Summer 2003, pp. 36-39.
 Hirosaki, N. et al., "High Durable SiAlON Phosphors" National Institute for Material Science, pp. 1-2.
 "First white LED using quantum dots created" © Sandia pp. 1-3.
 Inventions and Innovation Project Fact Sheet "Development of Phosphors for Use in High-Efficiency Lighting and Displays" Office of Industrial Technologies, Energy Efficiency and Renewable Energy, US Department of Energy, pp. 1-2.
 "A Solid Future for Lighting" Science and Technology, Economist.com, pp. 1-4.

"Innovations push white LEDs toward new applications" CompoundSemiconductor.net pp. 1-3.
 "Frequently Asked Questions about Solid-State Lighting" Sandia National Laboratories pp. 1-4.
 Bhat, J., et al., "High Power White LED Technology for Solid State Lighting" © Lumileds Lighting LLC Company Confidential pp. 1-40.
 Inventor's Feb. 8, 2008 Declaration for Compliance with Duty of Disclosure under 37 CFR§§1.56 with exhibits.
 Nov. 15, 2007 Office Action for U.S. Appl. No. 11/233,036.
 Nov. 8, 2007 Office Action for U.S. Appl. No. 10/558,481.
 Dec. 14, 2007 Office Action for U.S. Appl. No. 11/452,280.
 Dec. 20, 2007 Office Action for U.S. Appl. No. 11/589,942.
 "Developmental Product Technical Data Bulletin" Ferro Corporation-Specialty Plastics Group, Filled and Reinforced Plastics Division, Evansville, IN.
 "Industrial Equipment News . . . The Leading Publisher of New Products Worldwide" IEN, Apr. 2003, www.inquiryexpress.com.
 "Holographic Diffusers", EO Edmund Industrial Optics, available at <http://www.edmundoptics.com/onlinecatalog/DisplayProduct.cfm?productid=1363>.
 "Source Four Revolution", 2003.
 Steigervald, Daniel A., et al. "Illumination with Solid State Lighting Technology," IEEE Journal on Selected Topics in Quantum Electronics, vol. 8, No. 2, Mar./Apr. 2002, pp. 310-320.
 Xiang, Hector. "efg's Chromaticity Diagrams Lab Report." URL: <http://www.efg2.com/Lab/Graphics/Colors/Chromaticity.htm> pp. 1-15.
 Tawil, Joe, et al. "Colorimetry," URL: <http://www.cameraguild.com/technology/colorimetry.htm>, pp. 1-13.
 International Preliminary Report on Patentability, issued Nov. 1, 2006, concerning International Application No. PCT/US2005/014107, filed on Apr. 26, 2005, along with the Written Opinion of the International Searching Authority.
 U.S. Office Action issued in U.S. Appl. No. 11/233,036, dated May 30, 2007.
 European Search Report issued in European Patent Application No. 05756155.7-1268/1740350 dated on Jul. 2, 2008.
 Supplementary European Search Report issued in European Patent Application No. 05740253.9-1268/1740883 dated on Jul. 4, 2008.
 Supplementary European Search Report issued in European Patent Application No. 05758377.5-1268/1740883 dated on Jul. 2, 2008.
 * cited by examiner

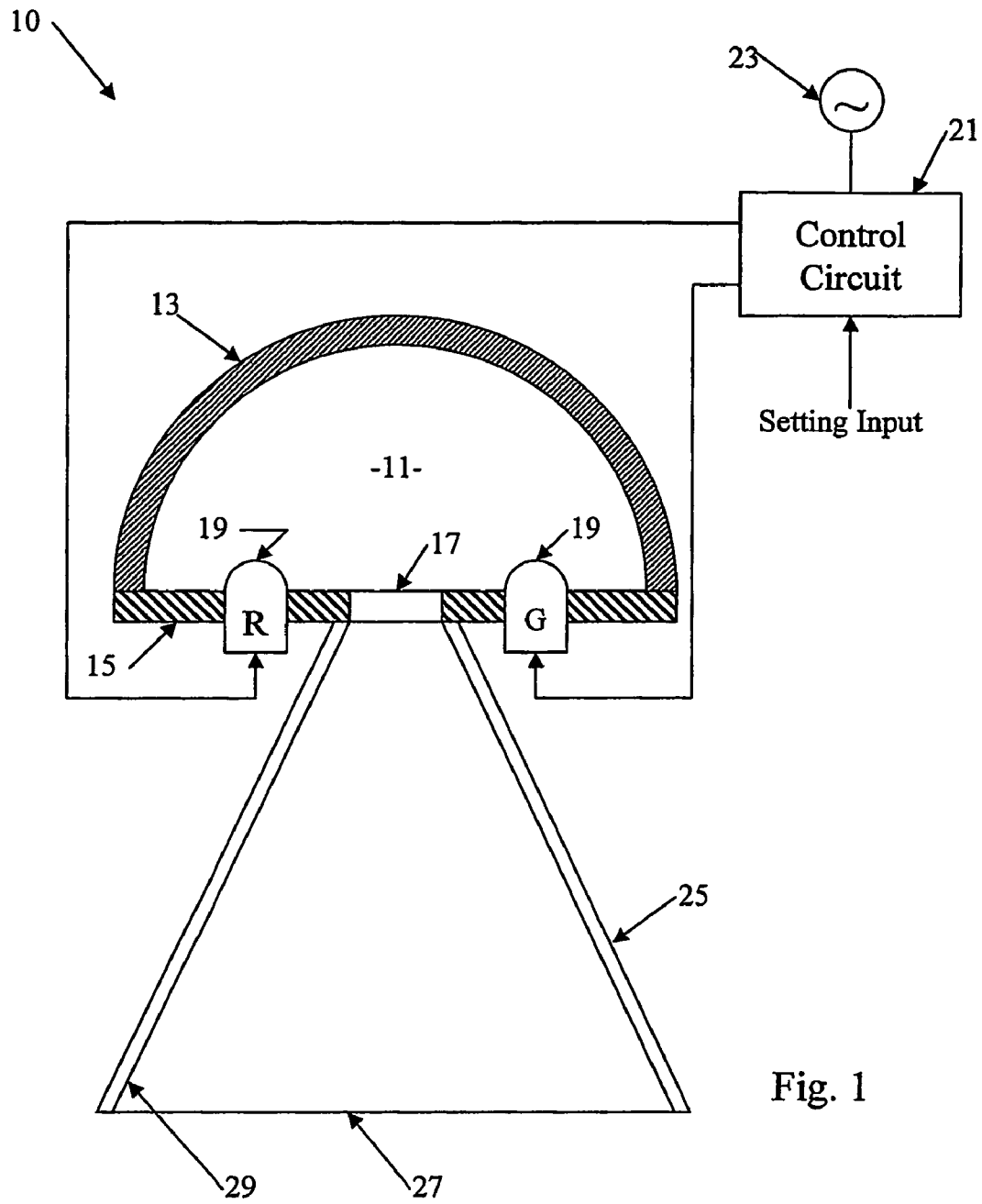

Fig. 1

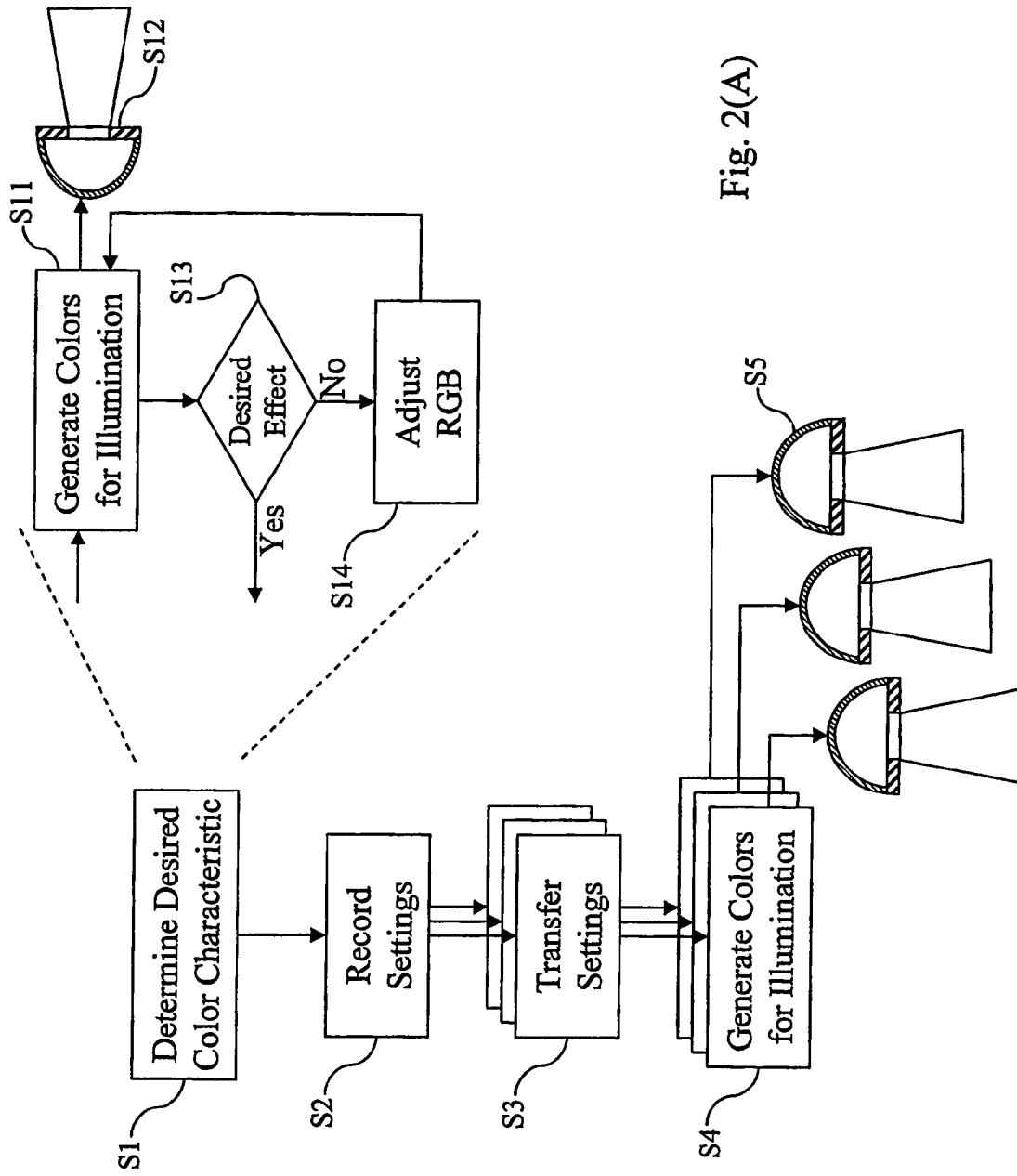

Fig. 2(A)

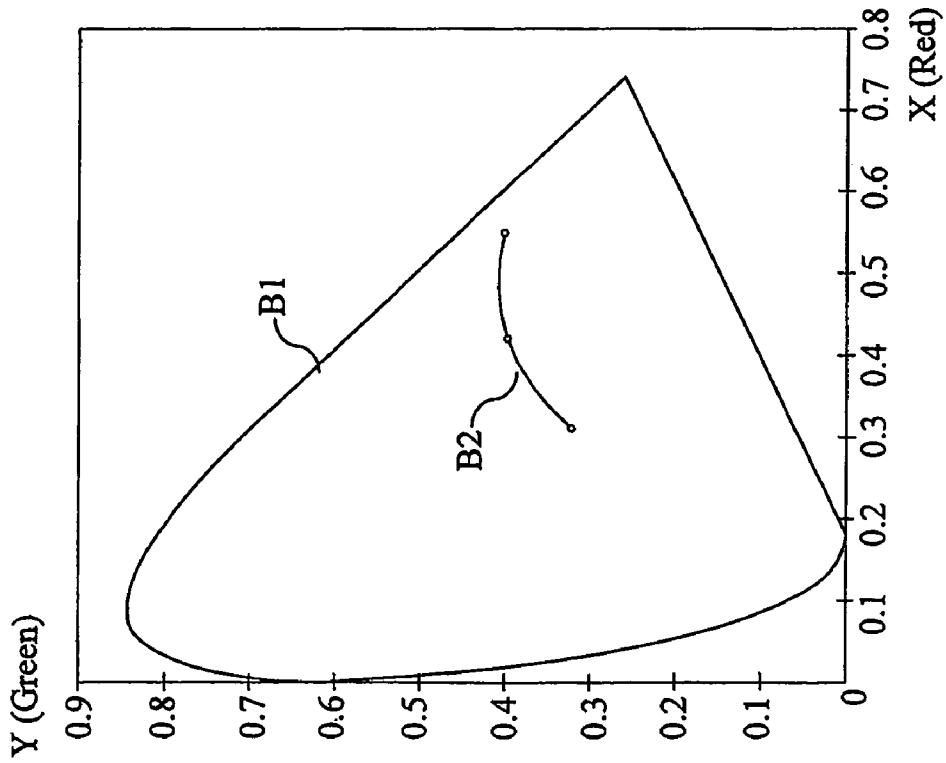

Fig. 2(B)

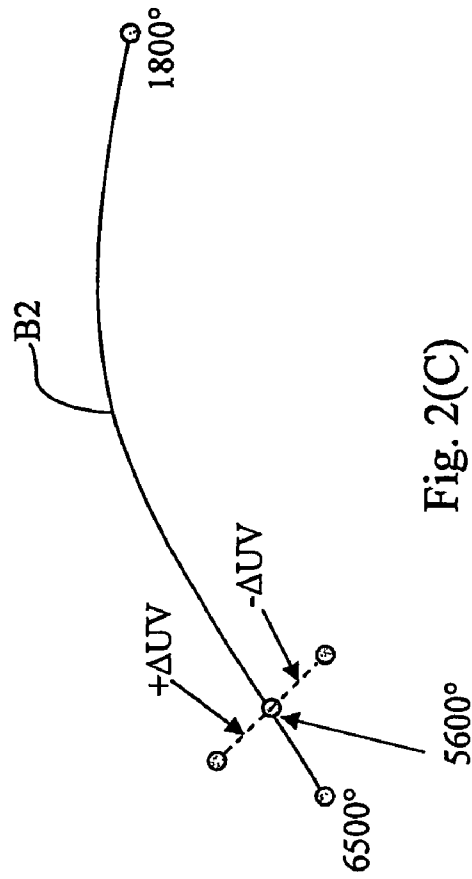
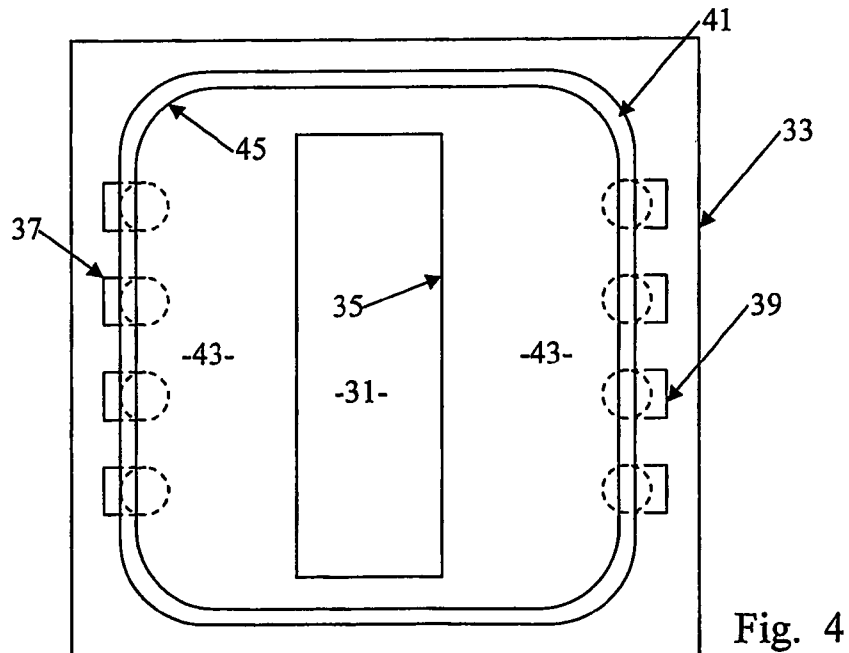
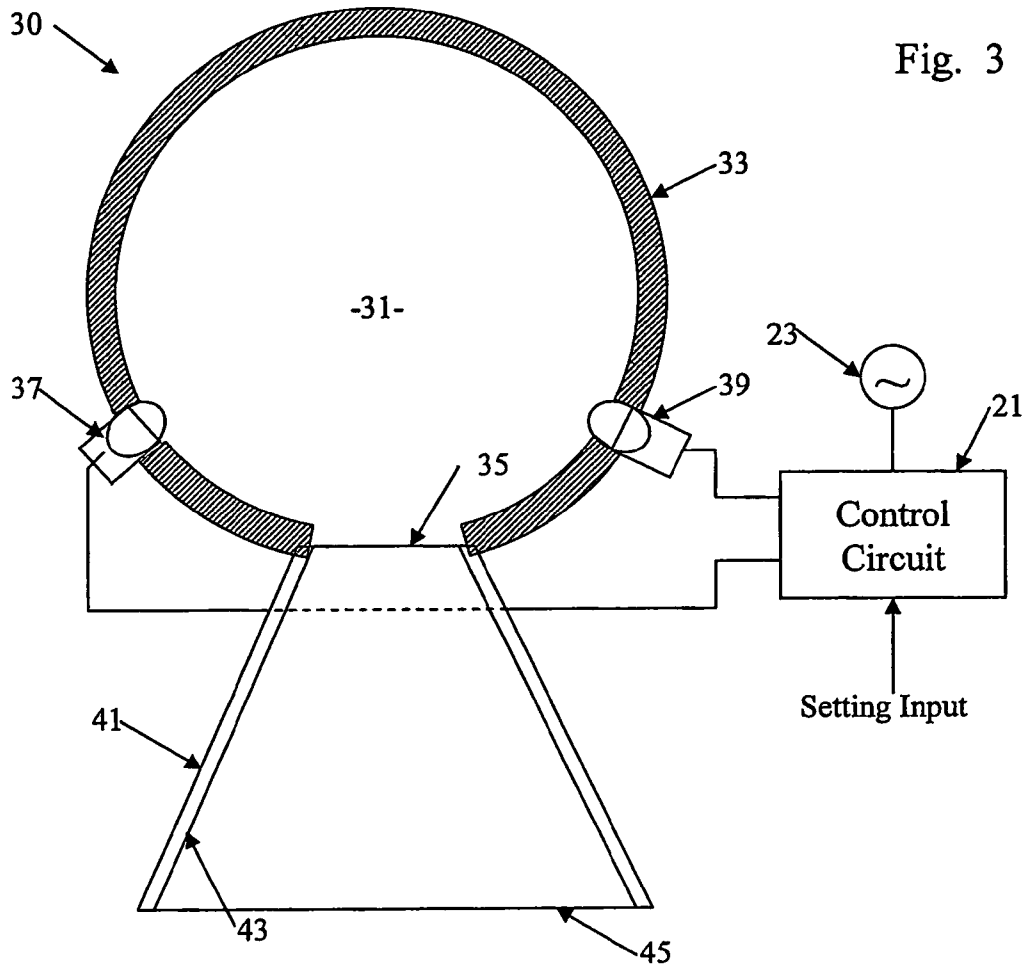

Fig. 2(C)



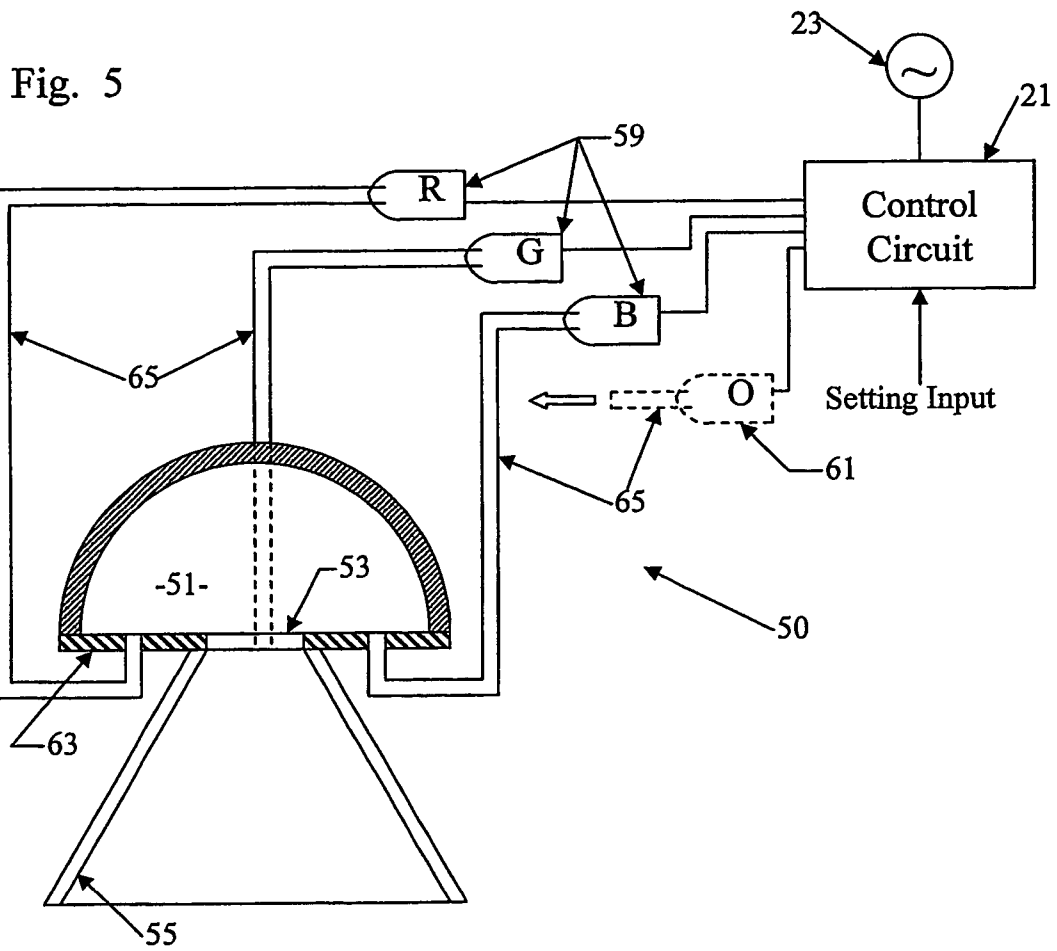

Fig. 6

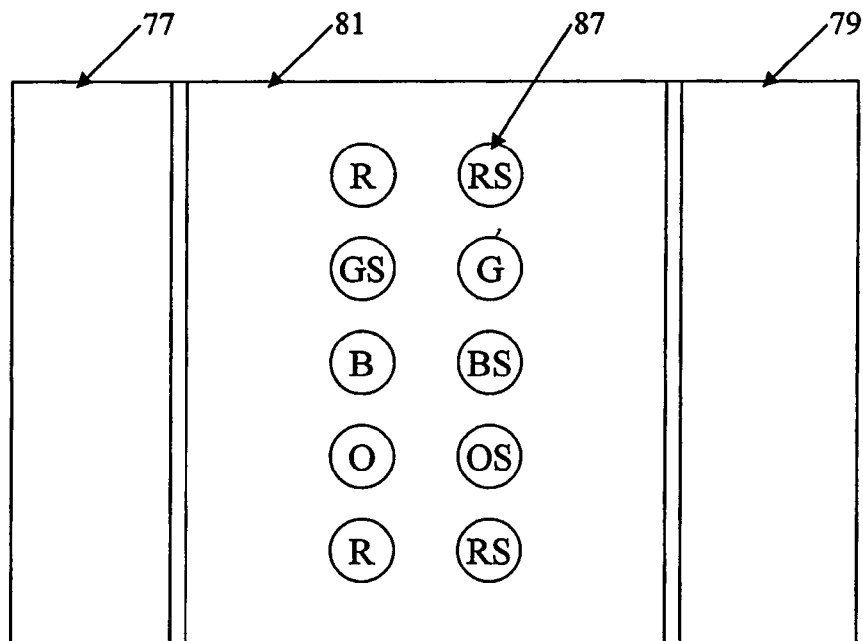
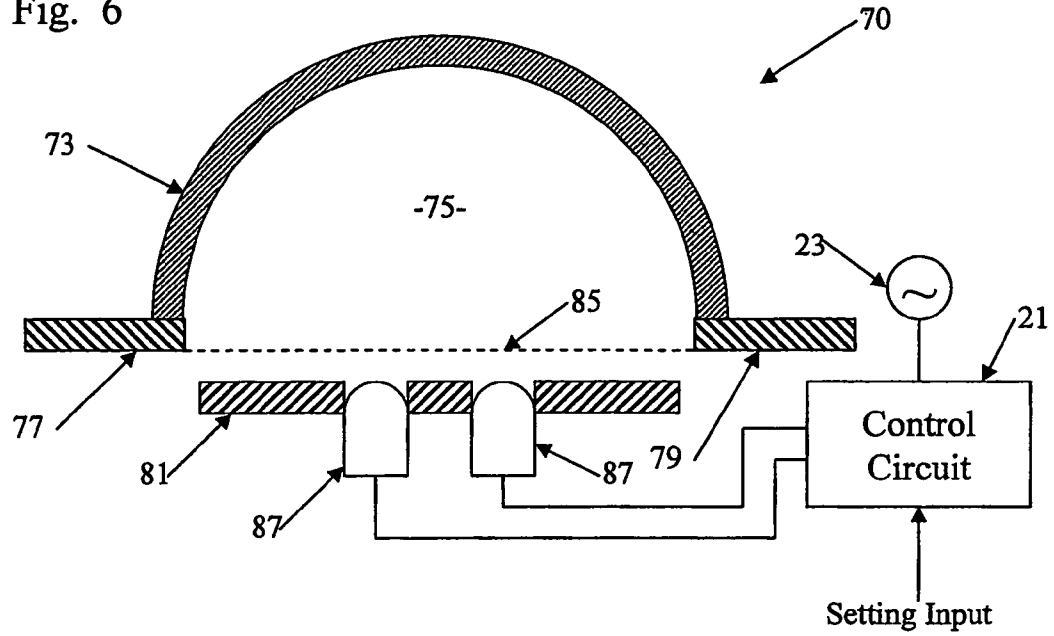

Fig. 7

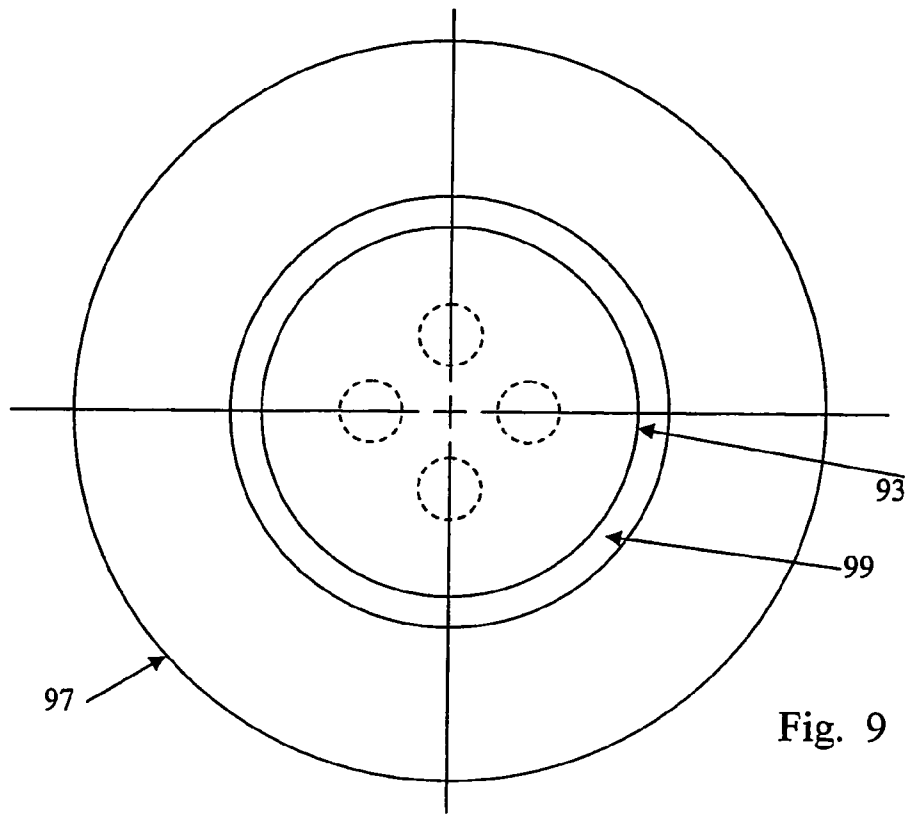

Fig. 9

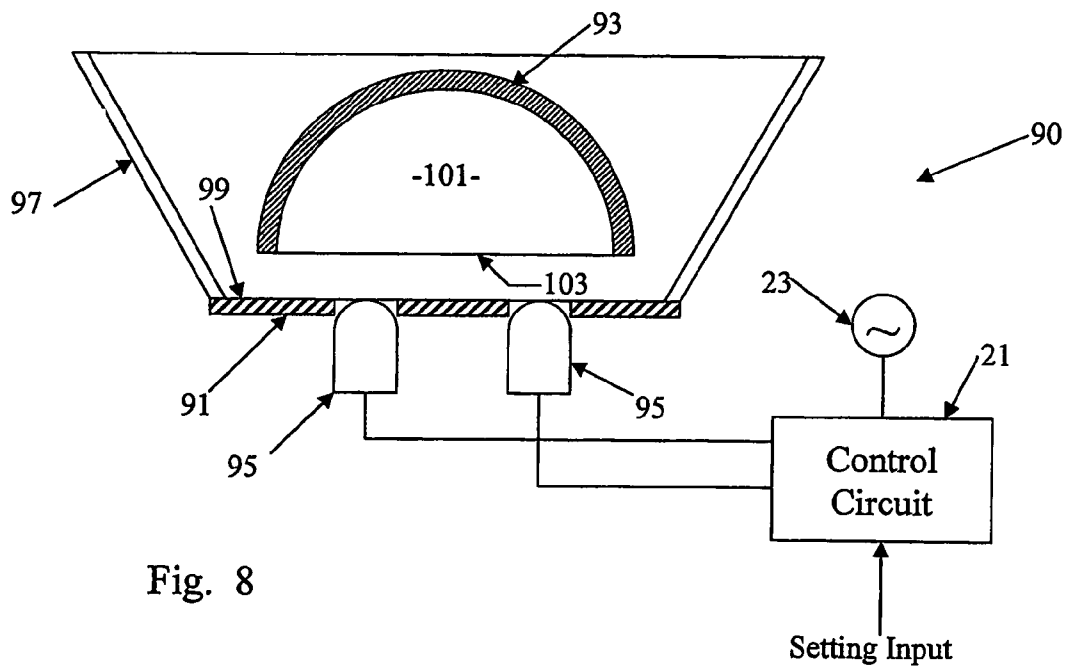

Fig. 8

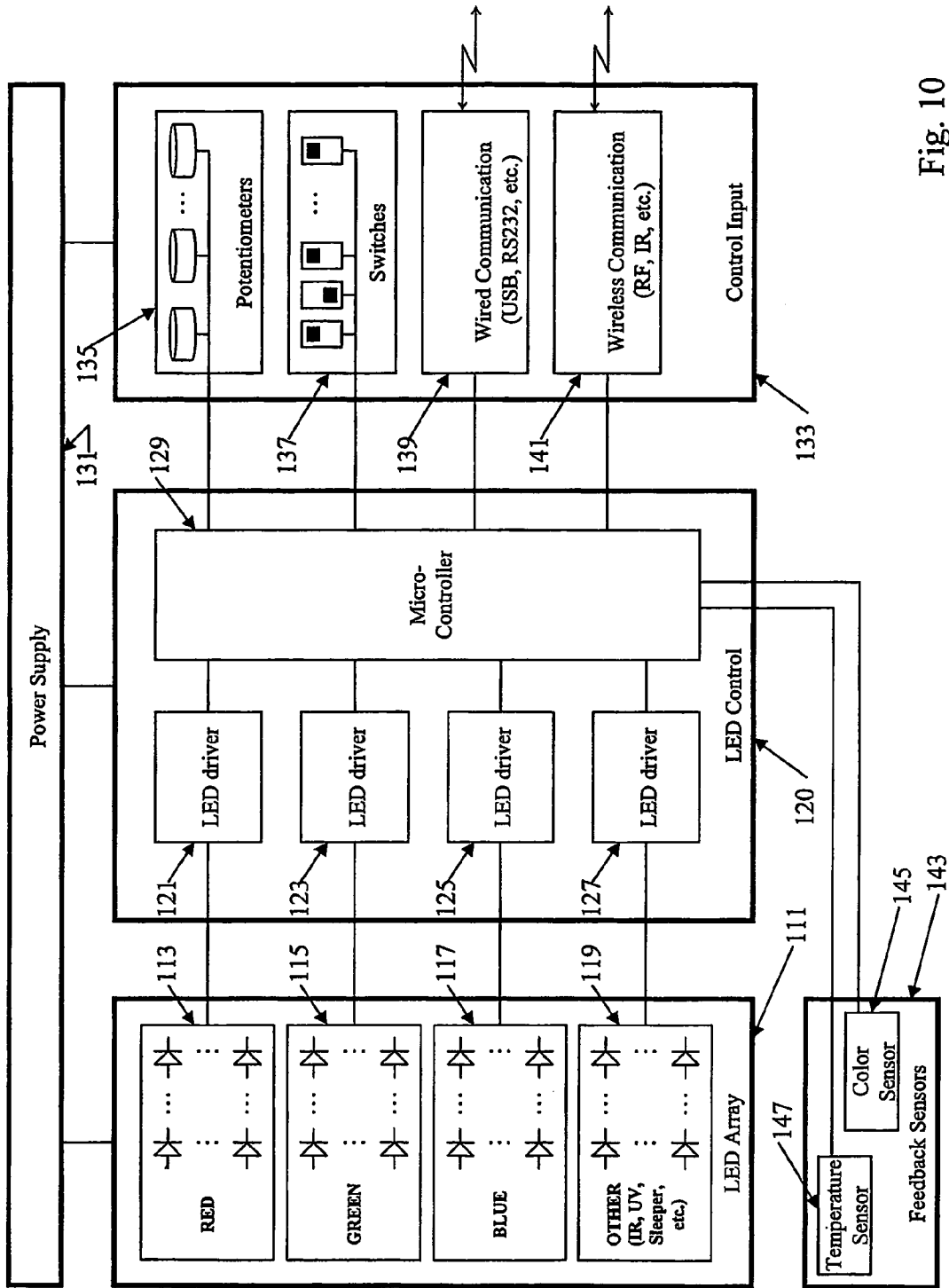

Fig. 10

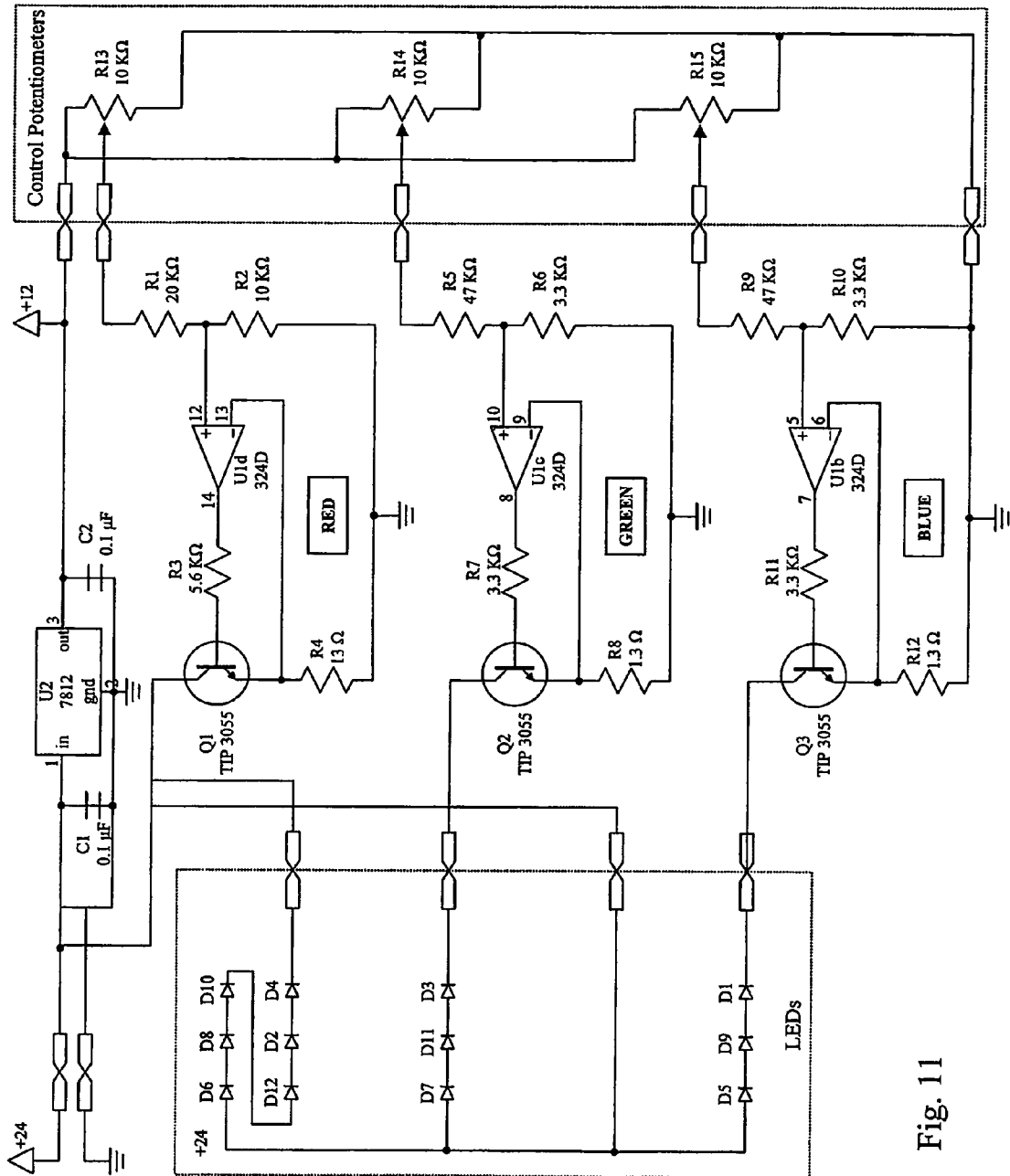

Fig. 11

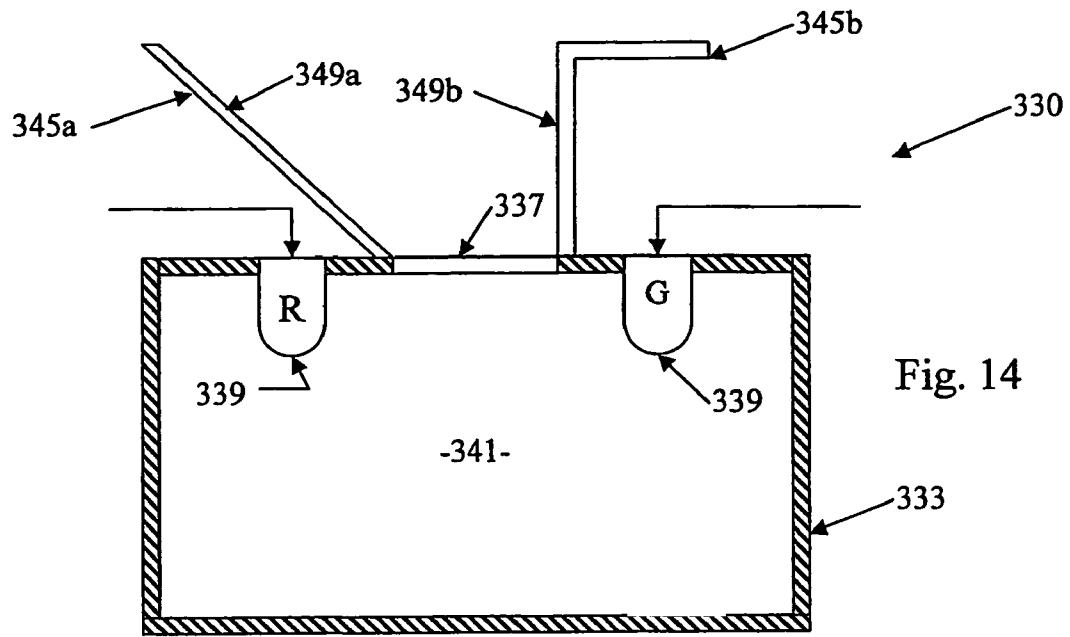

Fig. 14

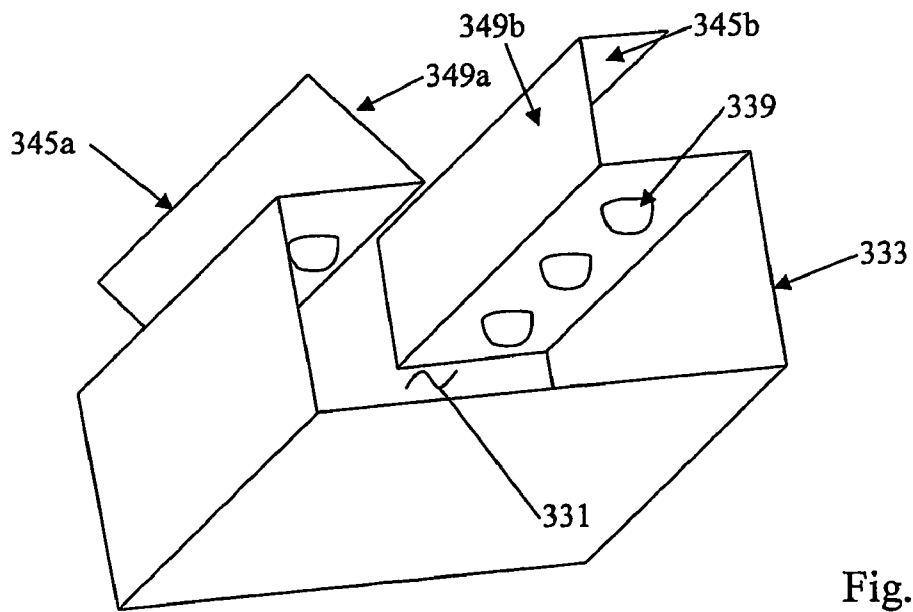

Fig. 15

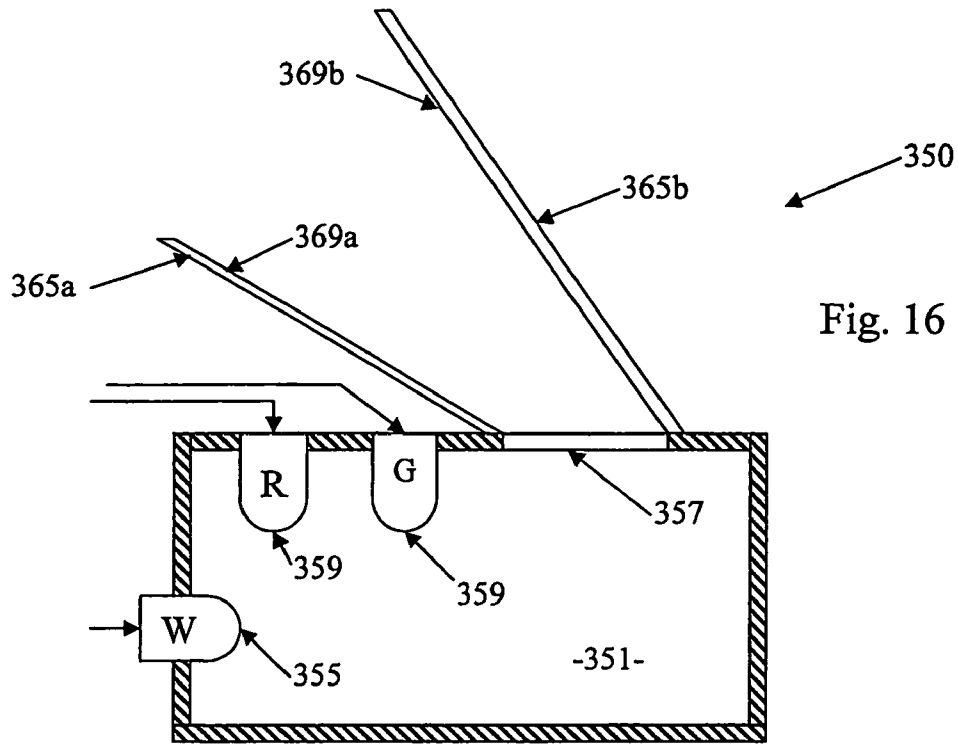

Fig. 16

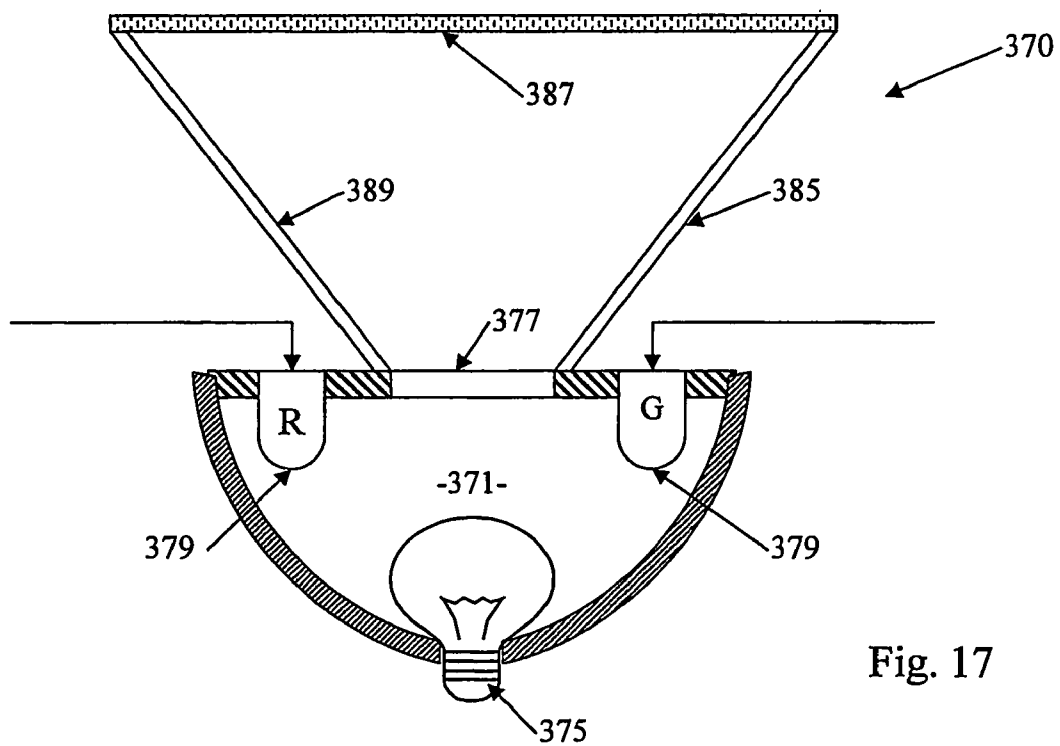

Fig. 17

**PRECISE REPEATABLE SETTING OF
COLOR CHARACTERISTICS FOR
LIGHTING APPLICATIONS**

RELATED APPLICATION

This application is the U.S. National Phase under 35 U.S.C. §371 of International application No. PCT/US2005/014107, filed Apr. 26, 2005, which claims priority from U.S. patent application Ser. No. 10/832,464 filed on Apr. 27, 2004.

This application also is a Continuation-In-Part and claims the benefit of the filing date of U.S. patent application Ser. No. 10/832,464 filed on Apr. 27, 2004, now U.S. Pat. No. 6,995,355, the disclosure of which is incorporated by reference herein.

TECHNICAL FIELD

The present subject matter relates to relatively precise, repeatable techniques to provide radiant energy having a selectable spectral characteristic (e.g. a selectable color characteristic), by selecting and combining amounts of light energy of different wavelengths from different sources.

BACKGROUND

An increasing variety of lighting applications require a precisely controlled spectral characteristic of the radiant energy. Applications for product illumination and photography have traditionally used color filters, to control the color of illumination, so as to provide certain desired lighting effects. Other approaches have used different white light sources, e.g. to provide somewhat warmer or cooler illumination, for different applications. However, color filters or selection of different sources providing somewhat different color temperature provides only very coarse control of the spectral characteristics of the applied light. Also, use of selected light sources compromises repeatability, as the spectral characteristic of the light often varies with the age of the particular light sources. Many illumination applications would benefit from a technique to more precisely control the spectral characteristics of illumination.

It has long been known that combining the light of one color with the light of another color creates a third color. For example, different amounts of the commonly used primary colors Red, Green and Blue can be combined to produce almost any color in the visible spectrum. Adjustment of the amount of each primary color enables adjustment of the spectral properties of the combined light stream. Recent developments for selectable color systems have utilized light emitting diodes as the sources of the different light colors.

Light emitting diodes (LEDs) were originally developed to provide visible indicators and information displays. For such luminance applications, the LEDs emitted relatively low power. However, in recent years, improved LEDs have become available that produce relatively high intensities of output light. These higher power LEDs, for example, have been used in arrays for traffic lights and are beginning to be deployed in more traditional illumination and task lighting applications. Today, LEDs are available in almost any color in the color spectrum.

Systems are known which combine controlled amounts of projected light from at least two LEDs of different primary colors to provide light of a selected color characteristic. Attention is directed, for example, to U.S. Pat. Nos. 6,459,919, 6,166,496 and 6,150,774. Typically, such systems have relied on using pulse-width modulation or other modulation

of the LED driver signals to adjust the intensity of each LED color output. U.S. Pat. No. 6,340,868 to Lys et al. suggests that an LED lighting assembly with pulse width modulated current control may be programmed to compensate for changes in color temperature, through a feedback mechanism. The modulation requires complex circuitry to implement. Also, such prior systems have relied on direct radiation or illumination from the individual source LEDs. In some applications, the LEDs may represent undesirably bright sources if viewed directly. Also, the direct illumination from LEDs providing multiple colors of light has not provided optimum combination throughout the field of illumination. In some systems, the observer can see the separate red, green and blue lights from the LEDs at short distances from the fixture, even if the LEDs are covered by a translucent diffuser. Integration of colors by the eye becomes effective only at longer distances.

Another problem arises from long-term use of LED type light sources. As the LEDs age, the output intensity for a given input level of the LED drive current decreases. As a result, it may be necessary to increase power to an LED to maintain a desired output level. This increases power consumption. In some cases, the circuitry may not be able to provide enough light to maintain the desired light output level. As performance of the LEDs of different colors declines differently with age (e.g. due to differences in usage), it may be difficult to maintain desired relative output levels and therefore difficult to maintain the desired spectral characteristics of the combined output. The output levels of LEDs also vary with actual temperature (thermal) that may be caused by difference in ambient conditions or different operational heating and/or cooling of different LEDs. Temperature induced changes in performance cause changes in the spectrum of light output.

Another problem with existing multi-color LED systems arises from control of the overall system output intensity. In existing systems, to adjust the combined output intensity, e.g. to reduce or increase overall brightness, the user must adjust the LED power levels. However, LED spectral characteristics change with changes in power level. If the light colors produced by the LEDs change, due to a power level adjustment, it becomes necessary to adjust the modulations to compensate in order to achieve the same spectral characteristic.

U.S. Pat. No. 6,007,225 to Ramer et al. (Assigned to Advanced Optical Technologies, L.L.C.) discloses a directed lighting system utilizing a conical light deflector. At least a portion of the interior surface of the conical deflector has a specular reflectivity. In several disclosed embodiments, the source is coupled to an optical integrating cavity; and an outlet aperture is coupled to the narrow end of the conical light deflector. This patented lighting system provides relatively uniform light intensity and efficient distribution of light over a field of illumination defined by the angle and distal edge of the deflector. However, this patent does not discuss particular color combinations or effects.

Hence, a need still exists for a technique to efficiently combine energy from multiple sources having multiple wavelengths and direct the radiant energy effectively toward a desired field of illumination, in a manner that allows relatively precise, repeatable control of the spectral character of the resulting illumination. A related need still exists for such a system that does not require complex electronics (e.g. modulation circuitry) to control the intensity of the energy output from the sources of the radiant energy of different wavelengths. A need also exists for a technique to effectively set and maintain a desired spectral character of the combined

output, e.g. as the performance of the source(s) changes with age or power or temperature, preferably without requiring excessive power levels.

SUMMARY

Techniques are disclosed herein, for determining settings for color inputs, to provide a desired illumination of a subject and for applying those settings to one or more systems that generate and mix the color inputs so as to provide combined light of the desired character.

Hence, a first disclosed method of illuminating a subject with light of a desired color characteristic involves determining settings relating to amounts of three colors of light, for providing the desired color characteristic. Data is recorded, which corresponds to the determined settings; and the data is transferred to a lighting system for use in illuminating the subject. In response to the data, the lighting system generates light of the three colors, in amounts corresponding to the determined settings. The method also involves diffusely reflecting the generated light of the three colors within a cavity, to produce combined light containing the three colors of light in amounts proportional to the determined settings. Combined light emerges through an aperture of the cavity, to illuminate the subject with light of the desired color characteristic for human observation of the illuminated object.

Human observation of the illuminated subject may involve direct viewing. In several examples, an observer views instances of an illuminated product on display in a store or the like. However, observation also may be indirect. For example, a person may be photographed while illuminated, and the picture distributed or communicated by any known means.

An example of the lighting system includes an optical cavity, having a diffusely reflective interior surface and an aperture for allowing emission of combined radiant energy. Sources supply light of the different colors into the interior of the cavity. The cavity effectively combines the energy of the different colors, so that the combined light emitted through the aperture includes the radiant energy of the various colors.

The sources can include any color or wavelength, but typically the examples use red, green, and blue light sources. One or more sources may also provide substantially white light. The integrating or mixing capability of the optical cavity serves to project light that appears to be white or substantially white to the human observer but exhibits a desired variation in color characteristic, by adjusting the intensity of the various sources coupled to the cavity. Hence, it is possible to control color temperature and a difference (Δ) from the standard color combination for that temperature.

A lighting system using an apparatus as disclosed herein will include a control circuit, coupled to the sources for establishing output intensity of radiant energy of each of the sources. Control of the intensity of emission of the sources sets a spectral characteristic of the combined radiant energy emitted through the aperture. If the fixture includes a variable iris, the output intensity may be adjusted by adjustment of the iris opening without the need to change the power levels of the sources, and thus without impact on the spectral characteristic of the output.

In the examples, each source typically comprises one or more light emitting diodes (LEDs). It is possible to install any desirable number of LEDs. Hence, In several examples, the sources may comprise one or more LEDs for emitting light of a first color, and one or more LEDs for emitting light of a second color, wherein the second color is different from the first color. In a similar fashion, the apparatus may include additional LED sources of a third color, a fourth color, etc. To

achieve the highest color-rendering index (CRI), the LED array may include LEDs of colors that effectively cover the entire visible spectrum. The lighting system works with the totality of light output from a family of LEDs. However, to provide color adjustment or variability, it is not necessary to control the output of individual LEDs, except as the intensity of each contributes to the totality. For example, it is not necessary to modulate the LED outputs. Also, the distribution pattern of the LEDs is not significant. The LEDs can be arranged in any manner to supply radiant energy within the optical cavity, although typically direct view from outside the fixture is avoided.

An exemplary system includes a number of "sleepers" LEDs that would be activated only when needed, for example, to maintain the light output, color, color temperature or thermal temperature. Hence, examples are also disclosed in which the first color LEDs comprise one or more initially active LEDs for emitting light of the first color and one or more initially inactive LEDs for emitting light of the first color on an as needed basis. Similarly, the second color LEDs include one or more initially active LEDs for emitting light of the second color and one or more initially inactive LEDs for emitting light of the second color on an as needed basis. In a similar fashion, the apparatus may include additional active and inactive LED sources of a third color, fourth color, etc. or active and inactive LED sources of white light.

As noted in the background, as LEDs age, they continue to operate, but at a reduced output level. The color characteristic may also vary with power level and/or temperature. The use of the sleeper LEDs greatly extends the lifecycle and the operational range of the fixtures. Activating a sleeper (previously inactive) LED, for example, provides compensation for the decrease in output of the originally active LED. There is also more flexibility in the range of intensities that the fixtures may provide under various operating conditions.

A number of different examples of control circuits are discussed below. In one example, the control circuitry comprises a color sensor coupled to detect color distribution in the combined radiant energy. Associated logic circuitry, responsive to the detected color distribution, controls the output intensity of the various LEDs, so as to provide a desired color distribution in the integrated radiant energy. In an example using sleeper LEDs, the logic circuitry is responsive to the detected color distribution to selectively activate one or more of the inactive light emitting diodes as needed, to maintain the desired color distribution in the combined light that illuminates the subject.

A number of other control circuit features also are disclosed. For example, the control circuitry may include an appropriate device for manually setting the desired spectral characteristic, for example, one or more variable resistors or one or more dip switches, to allow a user to define or select the desired color distribution. Automatic controls also are envisioned. For example, the control circuitry may include a data interface coupled to the logic circuitry, for receiving data defining the desired color distribution. Such an interface would allow input of control data from a separate or even remote device, such as a personal computer, personal digital assistant or the like. A number of the devices, with such data interfaces, may be controlled from a common central location or device. Examples are also disclosed with automatic selection data input, e.g. by sensing data recorded on or in association with a subject the system will illuminate.

A related method disclosed herein involves generating a variable amount of light of a first wavelength and a variable amount of light of a second wavelength. The two wavelengths are different. The light of these two wavelengths is optically

5

combined and used to illuminate the subject. This method involves adjusting the amount of the light of each wavelength, to achieve a color characteristic of a desired illumination of the subject. The amount of light of each wavelength in the combined light used to achieve the desired illumination of the subject is recorded. It then becomes possible to set a lighting system to generate the recorded amount of light of each wavelength, and the resulting light is optically combined to produce a combined light output corresponding to the desired illumination. Hence, irradiation of the subject with the combined light output from the lighting system achieves the desired illumination of the subject using the lighting system.

Another method disclosed herein serves to illuminate a subject with light of a desired color characteristic. This method involves setting first and second amounts for light of two different wavelengths and operating sources to generate light of both wavelengths at intensities corresponding to the respective set amounts. The first and second set amounts correspond to the desired color characteristic for the illumination of the subject. The method also entails diffusely reflecting the generated light of the two wavelengths within a cavity, to produce combined light containing amounts of light of the first and second wavelengths in proportion to the first and second set amounts. Emission of at least a portion of the combined light through an aperture of the cavity illuminates the subject, with light of the desired color characteristic.

Additional objects, advantages and novel features of the examples will be set forth in part in the description which follows, and in part will become apparent to those skilled in the art upon examination of the following and the accompanying drawings or may be learned by production or operation of the examples. The objects and advantages of the present subject matter may be realized and attained by means of the methodologies, instrumentalities and combinations particularly pointed out in the appended claims.

BRIEF DESCRIPTION OF THE DRAWINGS

The drawing figures depict one or more implementations in accord with the present concepts, by way of example only, not by way of limitations. In the figures, like reference numerals refer to the same or similar elements.

FIG. 1 illustrates an example of a radiant energy emitting system, with certain elements thereof shown in cross-section.

FIG. 2(A) is a flow diagram useful in understanding a process of setting a desired color characteristic for application in one or more of the systems of FIG. 1.

FIG. 2(B) depicts the chromaticity standard and black body curve.

FIG. 2(C) is an enlarged view of a representation of the black body curve.

FIG. 3 illustrates another example of a radiant energy emitting system, with certain elements thereof shown in cross-section.

FIG. 4 is a bottom view of the fixture in the system of FIG. 3.

FIG. 5 illustrates another example of a radiant energy emitting system, using fiber optic links from the LEDs to the optical integrating cavity.

FIG. 6 illustrates another example of a radiant energy emitting system, utilizing principles of constructive occlusion.

FIG. 7 is a bottom view of the fixture in the system of FIG. 6.

FIG. 8 illustrates another example of a radiant energy emitting system, utilizing principles of constructive occlusion.

FIG. 9 is a top plan view of the fixture in the system of FIG. 8.

6

FIG. 10 is a functional block diagram of the electrical components, of one of the radiant energy emitting systems, using programmable digital control logic.

FIG. 11 is a circuit diagram showing the electrical components, of one of the radiant energy emitting systems, using analog control circuitry.

FIG. 12 is a diagram, illustrating a number of radiant energy emitting systems with common control from a master control unit.

FIG. 13 is a cross-sectional view of another example of an optical cavity LED light fixture, using a collimator, iris and adjustable focusing system to process the combined light output.

FIG. 14 is a cross-sectional view of another example of an optical cavity LED light fixture, as might be used for a "wall-washer" application.

FIG. 15 is an isometric view of an extruded section of a fixture having the cross-section of FIG. 14.

FIG. 16 is a cross-sectional view of another example of an optical cavity LED light fixture, as might be used for a "wall-washer" application, using a combination of a white light source and a plurality of primary color light sources.

FIG. 17 is a cross-sectional view of another example of an optical cavity LED light fixture, in this case using a deflector and a combination of a white light source and a plurality of primary color light sources.

DETAILED DESCRIPTION

In the following detailed description, numerous specific details are set forth by way of examples in order to provide a thorough understanding of the relevant teachings. However, it should be apparent to those skilled in the art that the present teachings may be practiced without such details. In other instances, well known methods, procedures, components, and circuitry have been described at a relatively high-level, without detail, in order to avoid unnecessarily obscuring aspects of the present teachings.

Reference now is made in detail to the examples illustrated in the accompanying drawings and discussed below. FIG. 1 is a cross-sectional illustration of a radiant energy distribution apparatus or system 10. For illumination or task lighting applications, the apparatus emits light in the visible spectrum, although the system 10 may be used for other applications and/or with emissions in or extending into the infrared and/or ultraviolet portions of the radiant energy spectrum.

The illustrated system 10 includes an optical cavity 11 having a diffusely reflective interior surface, to receive and combine radiant energy of different colors/wavelengths. The cavity 11 may have various shapes. The illustrated cross-section would be substantially the same if the cavity is hemispherical or if the cavity is semi-cylindrical with the cross-section taken perpendicular to the longitudinal axis. The optical cavity in the examples discussed below is typically an optical integrating cavity.

The disclosed apparatus may use a variety of different structures or arrangements for the optical integrating cavity, examples of which are discussed below relative to FIGS. 3-9 and 13-17. At least a substantial portion of the interior surface(s) of the cavity exhibit(s) diffuse reflectivity. It is desirable that the cavity surface have a highly efficient reflective characteristic, e.g. a reflectivity equal to or greater than 90%, with respect to the relevant wavelengths. In the example of FIG. 1, the surface is highly diffusely reflective to energy in the visible, near-infrared, and ultraviolet wavelengths.

The cavity 11 may be formed of a diffusely reflective plastic material, such as a polypropylene having a 97% reflectivity.

tivity and a diffuse reflective characteristic. Such a highly reflective polypropylene is available from Ferro Corporation—Specialty Plastics Group, Filled and Reinforced Plastics Division, in Evansville, Ind. Another example of a material with a suitable reflectivity is SPECTRALON. Alternatively, the optical integrating cavity may comprise a rigid substrate having an interior surface, and a diffusely reflective coating layer formed on the interior surface of the substrate so as to provide the diffusely reflective interior surface of the optical integrating cavity. The coating layer, for example, might take the form of a flat-white paint or white powder coat. A suitable paint might include a zinc-oxide based pigment, consisting essentially of an uncalcined zinc oxide and preferably containing a small amount of a dispersing agent. The pigment is mixed with an alkali metal silicate vehicle-binder, which preferably is a potassium silicate, to form the coating material. For more information regarding the exemplary paint, attention is directed to U.S. patent application Ser. No. 09/866,516, which was filed May 29, 2001, by Matthew Brown, which issued as U.S. Pat. No. 6,700,112 on Mar. 2, 2004.

For purposes of the discussion, the cavity **11** in the apparatus **10** is assumed to be hemispherical. In the example, a hemispherical dome **13** and a substantially flat cover plate **15** form the optical cavity **11**. At least the interior facing surfaces of the dome **13** and the cover plate **15** are highly diffusely reflective, so that the resulting cavity **11** is highly diffusely reflective with respect to the radiant energy spectrum produced by the device **10**. As a result, the cavity **11** is an integrating type optical cavity. Although shown as separate elements, the dome and plate may be formed as an integral unit.

The optical integrating cavity **11** has an aperture **17** for allowing emission of combined radiant energy. In the example, the aperture **17** is a passage through the approximate center of the cover plate **15**, although the aperture may be at any other convenient location on the plate **15** or the dome **13**. Because of the diffuse reflectivity within the cavity **11**, light within the cavity is integrated before passage out of the aperture **17**. In the example, the apparatus **10** is shown emitting the combined radiant energy downward through the aperture **17**, for convenience. However, the apparatus **10** may be oriented in any desired direction to perform a desired application function, for example to provide visible illumination of persons or objects in a particular direction or location with respect to the fixture. Also, the optical integrating cavity **11** may have more than one aperture **17**, for example, oriented to allow emission of integrated light in two or more different directions or regions.

The apparatus **10** also includes sources of radiant energy of different wavelengths. In the first example, the sources are LEDs **19**, two of which are visible in the illustrated cross-section. The LEDs **19** supply radiant energy into the interior of the optical integrating cavity **11**. As shown, the points of emission into the interior of the optical integrating cavity are not directly visible through the aperture **17**. At least the two illustrated LEDs emit radiant energy of different colors, e.g. Red (R) and Green (G). Additional LEDs of the same or different colors may be provided. A typical example includes a Blue (B) LED. To achieve the highest color rendering index (CRI), the LED array may include LEDs of various wavelengths that cover virtually the entire visible spectrum. Examples with additional sources of substantially white light are discussed later. The cavity **11** effectively integrates the energy of different colors, so that the integrated or combined radiant energy emitted through the aperture **17** includes the radiant energy of all the various wavelengths in relative

amounts substantially corresponding to the relative intensities of input into the cavity **11**.

The integrating or mixing capability of the cavity **11** serves to project light of any color, including white light, by adjusting the intensity of the various sources coupled to the cavity. For example, in white light illumination applications, it is possible to control color temperature and to control differences in color from standard or normal values at the various temperatures. The system **10** works with the totality of light output from a family of LEDs **19**. However, to provide color adjustment or variability, it is not necessary to control the output of individual LEDs, except as they contribute to the totality. For example, it is not necessary to modulate the LED outputs. Also, the distribution pattern of the individual LEDs and their emission points into the cavity are not significant. The LEDs **19** can be arranged in any manner to supply radiant energy within the cavity, although it is preferred that direct view of the LEDs from outside the fixture is minimized or avoided.

In this example, light outputs of the LED sources **19** are coupled directly to openings at points on the interior of the cavity **11**, to emit radiant energy directly into the interior of the optical integrating cavity. The LEDs may be located to emit light at points on the interior wall of the element **13**, although preferably such points would still be in regions out of the direct line of sight through the aperture **17**. For ease of construction, however, the openings for the LEDs **19** are formed through the cover plate **15**. On the plate **15**, the openings/LEDs may be at any convenient locations.

The apparatus **10** also includes a control circuit **21** coupled to the LEDs **19** for establishing output intensity of radiant energy of each of the LED sources. The control circuit **21** typically includes a power supply circuit coupled to a source, shown as an AC power source **23**. The control circuit **21** also includes an appropriate number of LED driver circuits for controlling the power applied to each of the individual LEDs **19** and thus the intensity of radiant energy supplied to the cavity **11** for each different wavelength. Control of the intensity of emission of the sources sets a spectral characteristic of the combined radiant energy emitted through the aperture **17** of the optical integrating cavity. The control circuit **21** may be responsive to any one or more of a number of different user or automatic data input signals for setting the color intensities, as represented generically by the arrow in FIG. 1. Although not shown in this simple example, feedback may also be provided, for example, based on sensing of color or sensing of thermal temperature. Also, the system will often include initially active sources as well as spare initially inactive sources (“sleepers”), to provide a wider operational range and enable adjustment to compensate for LED degradation with age, power or thermal temperature. Specific examples of the control circuitry and use of such sleepers are discussed in more detail later.

The aperture **17** may serve as the system output, directing integrated color light to a desired area or region to be illuminated. Although not shown in this example, the aperture **17** may have a grate, lens or diffuser (e.g. a holographic element) to help distribute the output light and/or to close the aperture against entry of moisture or debris. For some applications, the system **10** includes an additional deflector to distribute and/or limit the light output to a desired field of illumination. A later embodiment, for example, uses a collimator. The color integrating energy distribution apparatus may also utilize one or more conical deflectors having a reflective inner surface, to efficiently direct most of the light emerging from a light source into a relatively narrow field of view.

Hence, the exemplary apparatus shown in FIG. 1 also comprises conical deflector 25. A small opening at a proximal end of the deflector is coupled to the aperture 17 of the optical integrating cavity 11. The deflector 25 has a larger opening 27 at a distal end thereof. The angle and distal opening of the conical deflector 25 define an angular field of radiant energy emission from the apparatus 10. Although not shown, the large opening of the deflector may be covered with a transparent plate or lens, or covered with a grating, to prevent entry of dirt or debris through the cone into the system and/or to further process the output radiant energy.

The conical deflector 25 may have a variety of different shapes, depending on the particular lighting application. In the example, where cavity 11 is hemispherical, the cross-section of the conical deflector is typically circular. However, the deflector may be somewhat oval in shape. In applications using a semi-cylindrical cavity, the deflector may be elongated or even rectangular in cross-section. The shape of the aperture 17 also may vary, but will typically match the shape of the small end opening of the deflector 25. Hence, in the example, the aperture 17 would be circular. However, for a device with a semi-cylindrical cavity and a deflector with a rectangular cross-section, the aperture may be rectangular.

The deflector 25 comprises a reflective interior surface 29 between the distal end and the proximal end. In some examples, at least a substantial portion of the reflective interior surface 29 of the conical deflector exhibits specular reflectivity with respect to the integrated radiant energy. As discussed in U.S. Pat. No. 6,007,225, for some applications, it may be desirable to construct the deflector 25 so that at least some portion(s) of the inner surface 29 exhibit diffuse reflectivity or exhibit a different degree of specular reflectivity (e.g., quasi-secular), so as to tailor the performance of the deflector 25 to the particular application. For other applications, it may also be desirable for the entire interior surface 29 of the deflector 25 to have a diffuse reflective characteristic. In such cases, the deflector 25 may be constructed using materials similar to those taught above for construction of the optical integrating cavity 11.

In the illustrated example, the large distal opening 27 of the deflector 25 is roughly the same size as the cavity 11. In some applications, this size relationship may be convenient for construction purposes. However, a direct relationship in size of the distal end of the deflector and the cavity is not required. The large end of the deflector 25 may be larger or smaller than the cavity structure. As a practical matter, the size of the cavity is optimized to provide the integration or combination of light colors from the desired number of LED sources 19. The size, angle and shape of the deflector determine the area that will be illuminated by the combined or integrated light emitted from the cavity 11 via the aperture 17.

A system such as that shown in FIG. 1 enables precise, repeatable control of the color characteristics of the light output by setting the intensity of each source. In many cases, the system may be controlled so as to produce light that the human observer will consider as white, yet with subtle adjustments of color to provide desired illumination effects.

Settings for a desirable color are easily reused or transferred from one system/fixture to another. If color/temperature/balance offered by particular settings are found desirable, e.g. to light a particular product on display or to illuminate a particular person or object in a studio or theater, it is a simple matter to record those settings and apply them at a later time. Similarly, such settings may be readily applied to another system or fixture, e.g. if the product is displayed at another location or if the person is appearing in a different studio or theater.

FIG. 2(A) is a simple flow chart useful in understanding these techniques for determining and setting desired color characteristics, for use in one or more lighting systems like the system 10. As shown at S1, the method of illuminating involves determining settings relating to amounts of three (or more) colors of light, for providing the desired color characteristic. The settings may be determined in a variety of ways. The settings may be estimated or determined by photometric measurements taken from the subject.

The example shows a series of sub-steps S11 to S14 for testing illumination of the subject in question and observing the results, until a desired effect is achieved. Hence, the subject is illuminated at S11-S12. Of note, the step S11 involves generating light of the three or more colors, which are integrated or mixed at S12 (using a system similar to system 10 of FIG. 1) for illumination of the subject. At S13, a determination is made as to whether the illumination achieves the desired color characteristic. The determination may be automatic, but often it is a subjective determination by a human observer through direct or indirect observation. If not, the process flows to step S14, at which the color amounts, e.g. the amounts of the RGB light input are adjusted. Illumination of the subject continues at S11 and S12.

The process of illuminating and adjusting the color amounts continues through sub-steps S11-S14, until the observer determines that the lighting provides the desired effects on the subject. In that event, the process at step S13 returns to the main routine, at which processing flows from step S1 to step S2. In step S2, data, which corresponds to the determined settings that produced the desired illumination, is recorded.

In a typical case, the combined light will generally be white to an observer, e.g. when looking directly at the subject or viewing a picture of the illuminated subject. However, the adjustment of the color amounts provides for subtle variations, that support the desired illumination of the individual subject. To appreciate these subtleties and how the settings may be recorded, it may be helpful to review some aspects of standard colorimetry.

FIG. 2(B) shows an approximation of the 1931 version of the CIE Chromaticity Diagram. The X axis represents red, and the Y axis represents green. The Z axis would be perpendicular to the plane of the diagram, and the Z axis represents blue. However, the three numbers must add up to 1, so typically, the diagram shows only the X and Y values. The Z value is computed from X and Y ($X+Y+Z=1$). The space within the shark-fin shaped boundary curve B1 represents the portion of the radiant energy spectrum that is typically visible to a human. Any color of light within the visible spectrum can be represented by values of X,Y,Z where the X-Y point falls within or on the boundary of the curve B 1 on this chromaticity chart. Formulae are also known for converting X, Y, Z chromaticity to/from primary color values, such as proportional amounts of red (R), green (G) and blue (B) or cyan (C), magenta (M) and yellow (Y), that will produce visible light corresponding to any point in or on the curve B1. Hence, X,Y,Z values or corresponding values for primary colors such as RGB can be used for any visible light, in this case, as determined at S1 and recorded at S2 in the process of FIG. 2(A) to produce the desired color characteristic for illumination of the subject. Of course other metrics may be used to provide data representative of the color settings.

Light that a human perceives as white or substantially white often is measured by a color temperature corresponding to a point on a standard curve approximated at B2 in the illustrations. The black body curve B2 corresponds to a locus of points on the diagram that represent light emitted from a

black body radiator at various temperatures, measured in degrees Kelvin. Of note for purposes of this discussion, light at points along the section of this curve corresponding approximately to 1800 to 6500 degrees Kelvin is typically perceived as visible white light, when objects illuminated by the light are viewed or otherwise observed by a human. A red tinged sunrise, for example, often is about 1800° K, on this curve. Normal sunlight, e.g. around midday on a clear day, is about 5600° K. FIG. 2(C) provides an enlargement of the curve B2.

For many desirable illumination effects, the light will appear white to the observer but will not fall precisely on the black body curve. The enlarged view of the curve shows two examples, at or near the 5600° K temperature for daylight illumination. At values around this temperature, the light will still appear much like daylight does, when an observer views an illuminated subject. However, changes in the precise X,Y,Z values (and corresponding RGB values or other component intensity values) produces subtle differences in color and thus differences in the illumination effect on the subject. The magnitudes of the differences are exaggerated somewhat in the drawing, for ease of illustration.

In the examples of FIG. 2(C), a white light value may be specified in terms of temperature (° K), which falls along the curve; and a difference is expressed as an X,Y,Z vector (ΔUV). Two such vectors are shown by way of example, one negative and one positive. The $-\Delta UV$ provides somewhat warmer illumination, as for example, might be used to highlight red elements of a product or product display arrangement. The $+\Delta UV$ provides somewhat cooler illumination, as for example, as might be used to highlight blue or green elements of a product or product display arrangement.

Returning to the process flow of FIG. 2(A), the determining step S1 identifies a particular visible color of light, corresponding to a point in the visible spectrum on the chart of FIG. 2(B), which provides the desired color characteristic for illumination of the particular subject. In step S2, data defining the point in the visible spectrum is recorded. In our example, the data may be X,Y,Z coordinates or corresponding values for relative RGB intensities. For white light illumination examples, the setting typically corresponds to a color temperature on the black body curve B2 and a difference vector ΔUV . The temperature and ΔUV vector may be used as the recorded data.

At S3, the recorded data is transferred to a lighting system for use in illuminating the subject. The data may be sent to a single system, but in many applications, the data is sent to a number of such systems. The receiving stations may be at the same location, at one other location or at many other locations. In response to the data, each lighting system generates light of the various component colors, RGB in our example (S4), in amounts corresponding to the determined settings. The methodology also involves diffusely reflecting the generated light of the colors within a cavity, to produce combined light containing the colors of light in amounts proportional to the determined settings (as represented by the step S5 in the drawing). Combined light emerges through an aperture of the cavity, to illuminate the subject with light of the desired color characteristic.

Although the receiving systems may be the same, they need not be identical or even particularly similar to each other, so long as they are capable of generating the specified colors in the proportions indicated by the setting data and combine those colors of light in an integrating chamber for output towards an example of the intended subject. If different color sources are used, e.g. CMY instead of RGB, it would only be necessary to translate the settings for the RGB type system to

corresponding settings for the CMY system. As the amounts of each color of light are controlled and integrated, each lighting system will illuminate the subject in substantially the same manner. In this way, the desired illumination effect is repeated by each system and/or each time a system illuminates an instance of the subject using the data for the color settings.

The methods for defining and transferring set conditions, e.g. for product lighting or personal lighting, can utilize manual recordings of settings and input of the settings to the different lighting systems. However, it is preferred to utilize digital control, in systems such as described below relative to FIGS. 10 and 12. Once input to a given lighting system, a particular set of parameters for a product or individual become a 'preset' lighting recipe stored in digital memory, which can be quickly and easily recalled and used each time that the particular product or person is to be illuminated. When using the digital implementation, the transfer of settings can be done automatically, for example, by inclusion of the setting data on a machine readable media incorporated into or included with a product and detectable by equipment associated with the computerized lighting control systems. Examples of such media include radio-frequency (RF) identification tags and bar codes. Other implementations may distribute the setting data via network communication.

It may be helpful to consider some examples of applications of these illumination techniques.

For a product, assume that a company will offer a new soft drink in a can having a substantial amount of red product markings. The company can test the product under lighting using one or more fixtures as described herein, to determine the optimum color to achieve a desired brilliant display. In a typical case, the light will generally be white to the observer. In the case of the red product container, the white light will have a relatively high level of red, to make the red markings seem to glow when the product is viewed by the casual observer/customer. When the company determines the appropriate settings for the new product, it can distribute those settings to the stores that will display and sell the product. The stores will use other fixtures of any type disclosed herein. The fixtures in the stores need not be of the exact same type that the company used during product testing. Each store uses the settings received from the company to establish the spectral characteristic(s) of the lighting applied to the product by the store's fixture(s), in our example, so that each product display provides the desired brilliant red illumination of the company's new soft drink product.

Consider now a studio lighting example for an actor or newscaster. The person is tested under lighting using one or more fixtures as described herein, to determine the optimum color to achieve desired appearance in video or film photography of the individual. Again, the light will generally appear white to the human observer seeing the person in the studio and/or seeing the resulting video or photograph. However, each person will appear better at somewhat different temperature (° K) and offset (ΔUV). One person might appear more healthy and natural under warmer light, whereas another might appear better under bluer/colder white light. After testing to determine the person's best light color settings, the settings are recorded. Each time the person appears under any lighting using the systems disclosed herein, in the same or a different studio, the technicians operating the lights can use the same settings to control the lighting and light the person with light of exactly the same spectral characteristic(s). Similar processes may be used to define a plurality of desirable lighting conditions for the actor or newscaster, for example, for illumination for different moods or different purposes of

the individual's performances or for live appearances or for different photographic equipment (e.g. video as opposed to film).

FIGS. 3 and 4 illustrate another example of a radiant energy distribution apparatus or system. FIG. 3 shows the overall system 30, including the fixture and the control circuitry. The fixture is shown in cross-section. FIG. 4 is a bottom view of the fixture. The system 30 is generally similar the system 10. For example, the system 30 may utilize essentially the same type of control circuit 21 and power source 23, as in the earlier example. However, the shape of the optical integrating cavity and the deflector are somewhat different.

The optical integrating cavity 31 has a diffusely reflective interior surface. In this example, the cavity 31 has a shape corresponding to a substantial portion of a cylinder. In the cross-sectional view of FIG. 3 (taken across the longitudinal axis of the cavity), the cavity 31 appears to have an almost circular shape. In this example, the cavity 31 is formed by a cylindrical element 33. At least the interior surface of the element 33 is highly diffusely reflective, so that the resulting optical cavity 31 is highly diffusely reflective and functions as an integrating cavity, with respect to the radiant energy spectrum produced by the system 30.

The optical integrating cavity 31 has an aperture 35 for allowing emission of combined radiant energy. In this example, the aperture 35 is a rectangular passage through the wall of the cylindrical element 33. Because of the diffuse reflectivity within the cavity 31, light within the cavity is integrated before passage out of the aperture 35.

The apparatus 30 also includes sources of radiant energy of different wavelengths. In this example, the sources comprise LEDs 37, 39. The LEDs are mounted in openings through the wall of the cylindrical element 33, to essentially form two rows of LEDs on opposite sides of the aperture 35. The positions of these openings, and thus the positions of the LEDs 37 and 39, typically are such that the LED outputs are not directly visible through the aperture 35, otherwise the locations are a matter of arbitrary choice.

Thus, the LEDs 37 and 39 supply radiant energy into the interior of the optical integrating cavity 31, through openings at points on the interior surface of the optical integrating cavity not directly visible through the aperture 35. A number of the LEDs emit radiant energy of different wavelengths. For example, arbitrary pairs of the LEDs 37, 39 might emit four different colors of light, e.g. Red, Green and Blue as primary colors and a fourth color chosen to provide an increased variability of the spectral characteristic of the integrated radiant energy. One or more white light sources, e.g. white LEDs, also may be provided.

Alternatively, a number of the LEDs may be initially active LEDs, whereas others are initially inactive sleeper LEDs. For example, the initially active LEDs might include two Red LEDs, two Green LEDs and a Blue LED; and the sleeper LEDs might include one Red LED, one Green LED and one Blue LED.

The control circuit 21 controls the power provided to each of the LEDs 37 and 39. The cavity 31 effectively integrates the energy of different wavelengths, from the various LEDs 37 and 39, so that the integrated radiant energy emitted through the aperture 35 includes the radiant energy of all the various wavelengths. Control of the intensity of emission of the sources, by the control circuit 21, sets a spectral characteristic of the combined radiant energy emitted through the aperture 35. If sleeper LEDs are provided, the control also activates one or more dormant LEDs, on an "as-needed" basis, when extra output of a particular wavelength or color is required. As discussed later with regard to an exemplary control circuit,

the system 30 could have a color sensor coupled to detect color of the combined light and provide feedback to the control circuit 21.

The color integrating energy distribution apparatus 30 may also include a deflector 41 having a specular reflective inner surface 43, to efficiently direct most of the light emerging from the aperture into a relatively narrow field of view. The deflector 41 expands outward from a small end thereof coupled to the aperture 35. The deflector 41 has a larger opening 45 at a distal end thereof. The angle of the side walls of the deflector and the shape of the distal opening 45 of the deflector 41 define an angular field of radiant energy emission from the apparatus 30.

As noted above, the deflector may have a variety of different shapes, depending on the particular lighting application. In the example, where the cavity 31 is substantially cylindrical, and the aperture is rectangular, the cross-section of the deflector 41 (viewed across the longitudinal axis as in FIG. 3) typically appears conical, since the deflector expands outward as it extends away from the aperture 35. However, when viewed on-end (bottom view—FIG. 4), the openings are substantially rectangular, although they may have somewhat rounded corners. Alternatively, the deflector 41 may be somewhat oval in shape. The shapes of the cavity and the aperture may vary, for example, to have rounded ends, and the deflector may be contoured to match the aperture.

The deflector 41 comprises a reflective interior surface 43 between the distal end and the proximal end. In several examples, at least a substantial portion of the reflective interior surface 43 of the conical deflector exhibits specular reflectivity with respect to the combined radiant energy, although different reflectivity may be provided, as noted in the discussion of FIG. 1.

In the examples discussed above relative to FIGS. 1, 3 and 4, the LED sources were coupled directly to openings at the points on the interior of the cavity, to emit radiant energy directly into the interior of the optical integrating cavity. It is also envisioned that the sources may be somewhat separated from the cavity, in which case, the device might include optical fibers or other forms of light guides coupled between the sources and the optical integrating cavity, to supply radiant energy from the sources to the emission points into the interior of the cavity. FIG. 5 depicts such a system 50, which uses optical fibers.

The system 50 includes an optical integrating cavity 51, an aperture 53 and a deflector with a reflective interior surface 55, similar to those in the earlier embodiments. The interior surface of the optical integrating cavity 51 is highly diffusely reflective, whereas the deflector surface 55 exhibits a specular reflectivity.

The system 50 includes a control circuit 21 and power source 23, as in the earlier embodiments. In the system 50, the radiant energy sources comprise LEDs 59 of three different wavelengths, e.g. to provide Red, Green and Blue light respectively. The sources may also include one or more additional LEDs 61, either white or of a different color or for use as 'sleepers,' similar to the example of FIGS. 3 and 4. In this example (FIG. 5), the cover plate 63 of the cavity 51 has openings into which are fitted the light emitting distal ends of optical fibers 65. The proximal light receiving ends of the fibers 65 are coupled to receive light emitted by the LEDs 59 (and 61 if provided). In this way, the LED sources 59, 61 may be separate from the chamber 51, for example, to allow easier and more effective dissipation of heat from the LEDs. The fibers 65 transport the light from the LED sources 59, 61 to the cavity 51. The cavity 51 integrates the different colors of light from the LEDs as in the earlier examples and supplies com-

bined light out through the aperture **53**. The deflector, in turn, directs the combined light to a desired field.

Again, the intensity control by the circuit **21** adjusts the amount or intensity of the light of each type provided by the LED sources and thus controls the spectral characteristic of the combined light output. A number of different examples of control circuits are discussed below. In one example, the control circuitry comprises a color sensor coupled to detect color distribution in the integrated radiant energy. Associated logic circuitry, responsive to the detected color distribution, controls the output intensity of the various LEDs, so as to provide a desired color distribution in the integrated radiant energy. In an example using sleeper LEDs, the logic circuitry is responsive to the detected color distribution to selectively activate the inactive light emitting diodes as needed, to maintain the desired color distribution in the integrated radiant energy.

To provide a uniform output distribution from the apparatus, it is also possible to construct the optical cavity so as to provide constructive occlusion. Constructive Occlusion type transducer systems utilize an electrical/optical transducer optically coupled to an active area of the system, typically the aperture of a cavity or an effective aperture formed by a reflection of the cavity. The systems utilize diffusely reflective surfaces, such that the active area exhibits a substantially Lambertian characteristic. A mask occludes a portion of the active area of the system, in the examples, the aperture of the cavity or the effective aperture formed by the cavity reflection, in such a manner as to achieve a desired response or output performance characteristic for the system. In examples of the present systems using constructive occlusion, the optical integrating cavity comprises a base, a mask and a cavity in either the base or the mask. The mask would have a diffusely reflective surface facing toward the aperture. The mask is sized and positioned relative to the active area so as to constructively occlude the active area. It may be helpful to consider two examples using constructive occlusion.

FIGS. **6** and **7** depict a first, simple embodiment of a light distributor apparatus or system **70**, for projecting integrated multi-wavelength light with a tailored intensity distribution, using the principles of constructive occlusion. In the cross-section illustration, the system **70** is oriented to provide downward illumination. Such a system might be mounted in or suspended from a ceiling or canopy or the like. Those skilled in the art will recognize that the designer may choose to orient the system **70** in different directions, to adapt the system to other lighting applications.

The lighting system **70** includes a base **73**, having or forming a cavity **75**, and adjacent shoulders **77** and **79**, constructed in a manner similar to the elements forming integrating cavities in the earlier examples. In particular, the interior of the cavity **75** is diffusely reflective, and the down-facing surfaces of shoulders **77** and **79** may be reflective. If the shoulder surfaces are reflective, they may be specular or diffusely reflective. A mask **81** is disposed between the cavity aperture **85** and the field to be illuminated. In this symmetrical embodiment, the interior wall of a half-cylindrical base **73** forms the cavity; therefore the aperture **85** is rectangular. The shoulders **77** formed along the sides of the aperture **85** are rectangular. If the base were circular, with a hemispherical cavity, the shoulders typically would form a ring that may partially or completely surround the aperture.

In many constructive occlusion embodiments, the cavity **75** comprises a substantial segment of a sphere. For example, the cavity may be substantially hemispherical, as in earlier examples. However, the cavity's shape is not of critical importance. A variety of other shapes may be used. In the

illustrated example, the half-cylindrical cavity **75** has a rectangular aperture, and if extended longitudinally, the rectangular aperture may approach a nearly linear aperture (slit). Practically any cavity shape is effective, so long as it has a diffusely reflective inner surface. A hemisphere or the illustrated half-cylinder shape are preferred for the ease in modeling for the light output toward the field of intended illumination and the attendant ease of manufacture. Also, sharp corners tend to trap some reflected energy and reduce output efficiency.

For purposes of constructive occlusion, the base **73** may be considered to have an active optical area, preferably exhibiting a substantially Lambertian energy distribution. Where the cavity is formed in the base, for example, the planar aperture **85** formed by the rim or perimeter of the cavity **75** forms the active surface with substantially Lambertian distribution of energy emerging through the aperture. As shown in a later embodiment, the cavity may be formed in the facing surface of the mask. In such a system, the surface of the base may be a diffusely reflective surface, therefore the active area on the base would essentially be the mirror image of the cavity aperture on the base surface, that is to say the area reflecting energy emerging from the physical aperture of the cavity in the mask.

The mask **81** constructively occludes a portion of the optically active area of the base with respect to the field of intended illumination. In the example of FIG. **6**, the optically active area is the aperture **85** of the cavity **75**; therefore the mask **81** occludes a substantial portion of the aperture **85**, including the portion of the aperture on and about the axis of the mask and cavity system. The surface of the mask **81** facing towards the aperture **85** is reflective. Although it may be specular, typically this surface is diffusely reflective.

The relative dimensions of the mask **81** and aperture **85**, for example the relative widths (or diameters or radii in a more circular system) as well as the distance of the mask **81** away from the aperture **85**, control the constructive occlusion performance characteristics of the lighting system **70**. Certain combinations of these parameters produce a relatively uniform emission intensity with respect to angles of emission, over a wide portion of the field of view about the system axis (vertically downward in FIG. **6**), covered principally by the constructive occlusion. Other combinations of size and height result in a system performance that is uniform with respect to a wide planar surface perpendicular to the system axis at a fixed distance from the active area.

The shoulders **77**, **79** also are reflective and therefore deflect at least some light downward. The shoulders (and side surfaces of the mask) provide additional optical processing of combined light from the cavity. The angles of the shoulders and the reflectivity of the surfaces thereof facing toward the region to be illuminated by constructive occlusion also contribute to the intensity distribution over that region. In the illustrated example, the reflective shoulders are horizontal, although they may be angled somewhat downward from the plane of the aperture.

With respect to the energy of different wavelengths, the interior space formed between the cavity **75** and the facing surface of the mask **81** operates as an optical integrating cavity, in essentially the same manner as the integrating cavities in the previous embodiments. Again, the LEDs provide light of a number of different wavelengths, and thus of different colors in the visible spectrum. The optical cavity combines the light of multiple colors supplied from the LEDs **87**. The control circuit **21** controls the amount of each color of light supplied to the chamber and thus the proportion thereof included in the combined output light. The constructive

occlusion serves to distribute that light in a desired manner over a field or area that the system **70** is intended to illuminate, with a tailored intensity distribution.

The LEDs **87** could be located at (or coupled by optical fiber to emit light) from any location or part of the surface of the cavity **75**. Preferably, the LED outputs are not directly visible through the un-occluded portions of the aperture **85** (between the mask and the edge of the cavity). In examples of the type shown in FIGS. **6** and **7**, the easiest way to so position the LED outputs is to mount the LEDs **87** (or provide fibers or the like) so as to supply light to the chamber through openings through the mask **81**.

FIG. **7** also provides an example of an arrangement of the LEDs in which there are both active and inactive (sleeper) LEDs of the various colors. As shown, the active part of the array of LEDs **87** includes two Red LEDs (R), one Green LED (G) and one Blue LED (B). The initially inactive part of the array of LEDs **87** includes two Red sleeper LEDs (RS), one Green sleeper LED (GS) and one Blue sleeper LED (BS). If other wavelengths or white light sources are desired, the apparatus may include an active LED of the other color (O) as well as a sleeper LED of the other color (OS). The precise number, type, arrangement and mounting technique of the LEDs and the associated ports through the mask **81** are not critical. The number of LEDs, for example, is chosen to provide a desired level of output energy (intensity), for a given application.

The system **70** includes a control circuit **21** and power source **23**. These elements control the operation and output intensity of each LED **87**. The individual intensities determine the amount of each color light included in the integrated and distributed output. The control circuit **21** functions in essentially the same manner as in the other examples.

FIGS. **8** and **9** illustrate a second constructive occlusion example. In this example, the physical cavity is actually formed in the mask, and the active area of the base is a flat reflective panel of the base.

The illustrated system **90** comprises a flat base panel **91**, a mask **93**, LED light sources **95**, and a conical deflector **97**. The system **90** is circularly symmetrical about a vertical axis, although it could be rectangular or have other shapes. The base **91** includes a flat central region **99** between the walls of the deflector **97**. The region **99** is reflective and forms or contains the active optical area on the base facing toward the region or area to be illuminated by the system **90**.

The mask **93** is positioned between the base **91** and the region to be illuminated by constructive occlusion. For example, in the orientation shown, the mask **93** is above the active optical area **99** of the base **91**, for example to direct light toward a ceiling for indirect illumination. Of course, the mask and cavity system could be inverted to serve as a down-light for task lighting applications, or the mask and cavity system could be oriented to emit light in directions appropriate for other applications.

In this example, the mask **93** contains the diffusely reflective cavity **101**, constructed in a manner similar to the integrating cavities in the earlier examples. The physical aperture **103** of the cavity **101** and of any diffusely reflective surface(s) of the mask **93** that may surround that aperture form an active optical area on the mask **93**. Such an active area on the mask faces away from the region to be illuminated and toward the active surface **99** on the base **91**. The surface **99** is reflective, preferably with a diffuse characteristic. The surface **99** of the base **91** essentially acts to produce a diffused mirror image of the mask **93** with its cavity **101** as projected onto the base area **99**. The reflection formed by the active area of the base becomes the effective aperture of the optical integrating cav-

ity (between the mask and base) when the fixture is considered from the perspective of the area of intended illumination. The surface area **99** reflects energy emerging from the aperture **103** of the cavity **101** in the mask **93**. The mask **93** in turn constructively occludes light diffused from the active base surface **99** with respect to the region illuminated by the system **90**. The dimensions and relative positions of the mask and active region on the base control the performance of the system, in essentially the same manner as in the mask and cavity system of FIGS. **6** and **7**.

The system **90** includes a control circuit **21** and associated power source **23**, for supplying controlled electrical power to the LED sources **95**. In this example, the LEDs emit light through openings through the base **91**, preferably at points not directly visible from outside the system. The LEDs **95** supply various wavelengths of light, and the circuit **21** controls the power of each LED, to control the amount of each color of light in the combined output, as discussed above relative to the other examples.

The base **91** could have a flat ring-shaped shoulder with a reflective surface. In this example, however, the shoulder is angled toward the desired field of illumination to form a conical deflector **97**. The inner surface of the deflector **97** is reflective, as in the earlier examples.

The deflector **97** has the shape of a truncated cone, in this example, with a circular lateral cross section. The cone has two circular openings. The cone tapers from the large end opening to the narrow end opening, which is coupled to the active area **99** of the base **91**. The narrow end of the deflector cone receives light from the surface **99** and thus from diffuse reflections between the base and the mask.

The entire area of the inner surface of the cone **97** is reflective. At least a portion of the reflective surface is specular, as in the deflectors of the earlier examples. The angle of the wall(s) of the conical deflector **97** substantially corresponds to the angle of the desired field of view of the illumination intended for the system **90**. Because of the reflectivity of the wall of the cone **97**, most if not all of the light reflected by the inner surface thereof would at least achieve an angle that keeps the light within the field of view.

The LED light sources **95** emit multiple wavelengths of light into the mask cavity **101**. The light sources **95** may direct some light toward the inner surface of the deflector **97**. Light rays impacting on the diffusely reflective surfaces, particularly those on the inner surface of the cavity **101** and the facing surface **99** of the base **91**, reflect and diffuse one or more times within the confines of the system and emerge through the gap between the perimeter of the active area **99** of the base and the outer edge of the mask **93**. The mask cavity **101** and the base surface **99** function as an optical integrating cavity with respect to the light of various wavelengths, and the gap becomes the actual integrating cavity aperture from which combined light emerges. The light emitted through the gap and/or reflected from the surface of the inner surface of the deflector **97** irradiates a region (upward in the illustrated orientation) with a desired intensity distribution and with a desired spectral characteristic, essentially as in the earlier examples.

Additional information regarding constructive occlusion based systems for generating and distributing radiant energy may be found in commonly assigned U.S. Pat. Nos. 6,342,695, 6,334,700, 6,286,979, 6,266,136 and 6,238,077. The color integration principles discussed herein may be adapted to any of the constructive occlusion devices discussed in those patents.

The inventive devices have numerous applications, and the output intensity and spectral characteristic may be tailored

and/or adjusted to suit the particular application. For example, the intensity of the integrated radiant energy emitted through the aperture may be at a level for use in a rumination application or at a level sufficient for a task lighting application. A number of other control circuit features also may be implemented. For example, the control may maintain a set color characteristic in response to feedback from a color sensor. The control circuitry may also include a temperature sensor. In such an example, the logic circuitry is also responsive to the sensed thermal temperature, e.g. to reduce intensity of the source outputs to compensate for temperature increases while maintaining a set color characteristic. The control circuitry may include an appropriate device for manually setting the desired spectral characteristic, for example, one or more variable resistors or one or more dip switches, to allow a user to define or select the desired color distribution.

Automatic controls also are envisioned. For example, the control circuitry may include a data interface coupled to the logic circuitry, for receiving data defining the desired color distribution. Such an interface would allow input of control data from a separate or even remote device, such as a personal computer, personal digital assistant or the like. A number of the devices, with such data interfaces, may be controlled from a common central location or device. Automatic reception or sensing of information, to obtain setting data, also is encompassed by the present teachings. The light settings are easily recorded and reused at a later time or even at a different location using a different system.

To appreciate the features and examples of the control circuitry outlined above, it may be helpful to consider specific examples with reference to appropriate diagrams.

FIG. 10 is a block diagram of exemplary circuitry for the sources and associated control circuit, providing digital programmable control, which may be utilized with a light integrating fixture of the type described above. In this circuit example, the sources of radiant energy of the various types takes the form of an LED array 111. The array 111 comprises two or more LEDs of each of the three primary colors, red green and blue, represented by LED blocks 113, 115 and 117. For example, the array may comprise six red LEDs 113, three green LEDs 115 and three blue LEDs 117.

The LED array in this example also includes a number of additional or "other" LEDs 119. There are several types of additional LEDs that are of particular interest in the present discussion. One type of additional LED provides one or more additional wavelengths of radiant energy for integration within the chamber. The additional wavelengths may be in the visible portion of the light spectrum, to allow a greater degree of color adjustment.

The second type of additional LED that may be included in the system is a sleeper LED. As discussed above, some LEDs would be active, whereas the sleepers would be inactive, at least during initial operation. Using the circuitry of FIG. 10 as an example, the Red LEDs 113, Green LEDs 115 and Blue LEDs 117 might normally be active. The LEDs 119 would be sleeper LEDs, typically including one or more LEDs of each color used in the particular system.

The third type of other LED of interest is a white LED. For white lighting applications, one or more white LEDs provide increased intensity. The primary color LEDs then provide light for color adjustment and/or correction to achieve a desired color temperature and ΔUV .

The electrical components shown in FIG. 10 also include an LED control system 120. The system 120 includes driver circuits for the various LEDs and a microcontroller. The driver circuits supply electrical current to the respective LEDs 113 to 119 to cause the LEDs to emit light. The driver circuit

121 drives the Red LEDs 113, the driver circuit 123 drives the green LEDs 115, and the driver circuit 125 drives the Blue LEDs 117. In a similar fashion, when active, the driver circuit 127 provides electrical current to the other LEDs 119. If the other LEDs provide another color of light, and are connected in series, there may be a single driver circuit 127. If the LEDs are sleepers, it may be desirable to provide a separate driver circuit 127 for each of the LEDs 119. The intensity of the emitted light of a given LED is proportional to the level of current supplied by the respective driver circuit.

The current output of each driver circuit is controlled by the higher level logic of the system. In this digital control example, that logic is implemented by a programmable microcontroller 129, although those skilled in the art will recognize that the logic could take other forms, such as discrete logic components, an application specific integrated circuit (ASIC), etc.

The LED driver circuits and the microcontroller 129 receive power from a power supply 131, which is connected to an appropriate power source (not separately shown). For most illumination applications, the power source will be an AC line current source, however, some applications may utilize DC power from a battery or the like. The power supply 129 converts the voltage and current from the source to the levels needed by the driver circuits 121-127 and the microcontroller 129.

A programmable microcontroller typically includes or has coupled thereto random-access memory (RAM) for storing data and read-only memory (ROM) and/or electrically erasable read only memory (EEROM) for storing control programming and any pre-defined operational parameters, such as pre-established light 'recipes.' The microcontroller 129 itself comprises registers and other components for implementing a central processing unit (CPU) and possibly an associated arithmetic logic unit. The CPU implements the program to process data in the desired manner and thereby generate desired control outputs.

The microcontroller 129 is programmed to control the LED driver circuits 121-127 to set the individual output intensities of the LEDs to desired levels, so that the combined light emitted from the aperture of the cavity has a desired spectral characteristic and a desired overall intensity. The microcontroller 129 may be programmed to essentially establish and maintain or preset a desired 'recipe' or mixture of the available wavelengths provided by the LEDs used in the particular system to provide desired illumination of an identified subject. The microcontroller 129 receives control inputs specifying the particular 'recipe' or mixture, as will be discussed below. To insure that the desired mixture is maintained, the microcontroller receives a color feedback signal from an appropriate color sensor. The microcontroller may also be responsive to a feedback signal from a temperature sensor, for example, in or near the optical integrating cavity.

The electrical system will also include one or more control inputs 133 for inputting information instructing the microcontroller 129 as to the desired operational settings. A number of different types of inputs may be used, and several alternatives are illustrated for convenience. A given installation may include a selected one or more of the setting data input mechanisms.

As one example, user inputs may take the form of a number of potentiometers 135. The number would typically correspond to the number of different light wavelengths provided by the particular LED array 111. The potentiometers 135 typically connect through one or more analog to digital conversion interfaces provided by the microcontroller 129 (or in associated circuitry). To set the parameters for the integrated

light output, the user adjusts the potentiometers **135** to set the intensity for each color. The microcontroller **129** senses the input settings and controls the LED driver circuits accordingly, to set corresponding intensity levels for the LEDs providing the light of the various wavelengths.

Another user input implementation might utilize one or more dip switches **137**. For example, there might be a series of such switches to input a code corresponding to one of a number of recipes. The memory used by the microcontroller **129** would store the necessary intensity levels for the different color LEDs in the array **111** for each recipe. Based on the input code, the microcontroller **129** retrieves the appropriate recipe from memory. Then, the microcontroller **129** controls the LED driver circuits **121-127** accordingly, to set corresponding intensity levels for the LEDs **113-119** providing the light of the various wavelengths.

As an alternative or in addition to the user input in the form of potentiometers **135** or dip switches **137**, the microcontroller **129** may be responsive to control data supplied from a separate source or a remote source. For that purpose, some versions of the system will include one or more communication interfaces. One example of a general class of such interfaces is a wired interface **139**. One type of wired interface typically enables communications to and/or from a personal computer or the like, typically within the premises in which the fixture operates. Examples of such local wired interfaces include USB, RS-232, and wire-type local area network (LAN) interfaces. Other wired interfaces, such as appropriate modems, might enable cable or telephone line communications with a remote computer, typically outside the premises. Other examples of data interfaces provide wireless communications, as represented by the interface **141** in the drawing. Wireless interfaces, for example, use radio frequency (RF) or infrared (IR) links. The wireless communications may be local on-premises communications, analogous to a wireless local area network (WLAN). Alternatively, the wireless communications may enable communication with a remote device outside the premises, using wireless links to a wide area network.

The automatic inputs allow communication from any of a variety of other equipment, to input one or more of the color "recipes." Those skilled in the art will understand that these interfaces also enable the system to receive identifiers corresponding to subjects to be illuminated, for use in selecting and applying the appropriate stored recipe. These interfaces may also enable the system to receive, store and apply settings automatically, e.g. from RFID tags or bar codes on products, packages, business cards, or the like.

As noted above, the electrical components may also include one or more feedback sensors **143**, to provide system performance measurements as feedback signals to the control logic, implemented in this example by the microcontroller **129**. A variety of different sensors may be used, alone or in combination, for different applications. In the illustrated examples, the set **143** of feedback sensors includes a color sensor **145** and a thermal temperature sensor **147**. Although not shown, other sensors, such as an overall intensity sensor may be used. The sensors are positioned in or around the system to measure the appropriate physical condition, e.g. temperature, color, intensity, etc.

The color sensor **145**, for example, is coupled to detect color distribution in the integrated radiant energy. The color sensor may be coupled to sense energy within the optical integrating cavity, within the deflector (if provided) or at a point in the field illuminated by the particular system. If some small amount of the integrated light passes through a point on a wall of the cavity, it may be sufficient to sense color at that

point on the cavity wall. Various examples of appropriate color sensors are known. For example, the color sensor may be a digital compatible sensor, of the type sold by TAOS, Inc. Another suitable sensor might use the quadrant light detector disclosed in U.S. Pat. No. 5,877,490, with appropriate color separation on the various light detector elements (see U.S. Pat. No. 5,914,487 for discussion of the color analysis).

The associated logic circuitry, responsive to the detected color distribution, controls the output intensity of the various LEDs, so as to provide a desired color distribution in the integrated radiant energy, in accord with appropriate settings. In an example using sleeper LEDs, the logic circuitry is responsive to the detected color distribution to selectively activate the inactive light emitting diodes as needed, to maintain the desired color distribution in the integrated radiant energy. The color sensor measures the color of the integrated radiant energy produced by the system and provides a color measurement signal to the microcontroller **129**. If using the TAOS, Inc. color sensor, for example, the signal is a digital signal derived from a color to frequency conversion.

The thermal temperature sensor **147** may be a simple thermoelectric transducer with an associated analog to digital converter, or a variety of other temperature detectors may be used. The temperature sensor is positioned on or inside of the fixture, typically at a point that is near the LEDs or other sources that produce most of the system heat. The temperature sensor **147** provides a signal representing the measured temperature to the microcontroller **129**. The system logic, here implemented by the microcontroller **129**, can adjust intensity of one or more of the LEDs in response to the sensed temperature, e.g. to reduce intensity of the source outputs to compensate for temperature increases. The program of the microcontroller **129**, however, would typically manipulate the intensities of the various LEDs so as to maintain the desired color balance between the various wavelengths of light used in the system, even though it may vary the overall intensity with temperature. For example, if temperature is increasing due to increased drive current to the active LEDs (with increased age or heat), the controller may deactivate one or more of those LEDs and activate a corresponding number of the sleepers, since the newly activated sleeper(s) will provide similar output in response to lower current and thus produce less heat.

The above discussion of FIG. **10** related to programmed digital implementations of the control logic. Those skilled in the art will recognize that the control also may be implemented using analog circuitry. FIG. **11** is a circuit diagram of a simple analog control for a lighting apparatus (e.g. of the type shown in FIG. **1**) using Red, Green and Blue LEDs. The user establishes the levels of intensity for each type of radiant energy emission (Red, Green or Blue) by operating a corresponding one of the potentiometers. The circuitry essentially comprises driver circuits for supplying adjustable power to two or three sets of LEDs (Red, Green and Blue) and analog logic circuitry for adjusting the output of each driver circuit in accord with the setting of a corresponding potentiometer. Additional potentiometers and associated circuits would be provided for additional colors of LEDs. Those skilled in the art should be able to implement the illustrated analog driver and control logic of FIG. **11** without further discussion.

Some lighting applications involve a common overall control strategy for a number of the systems. As noted in the discussion of FIG. **10**, the control circuitry may include a communication interface **139** or **141** allowing the microcontroller **129** to communicate with another processing system. FIG. **12** illustrates an example in which control circuits **21** of a number of the radiant energy generation systems with the

light integrating and distribution type fixture communicate with a master control unit **151** via a communication network **153**. The master control unit **151** typically is a programmable computer with an appropriate user interface, such as a personal computer or the like. The communication network **153** may be a LAN or a wide area network, of any desired type. The communications allow an operator to control the color and output intensity of all of the linked systems, for example to provide combined lighting effects or to control lighting of a large product display. The commonly controlled lighting systems may be arranged in a variety of different ways, depending on the intended use of the systems.

The systems described above have a wide range of applications, where there is a desire to set or adjust color provided by a lighting fixture. Applications may include task lighting, however, applications of particular interest relate to illuminating an object or person in a manner that provides precise control and repeatability of the spectral (color) characteristics of the illumination.

FIG. **13** illustrates another example of a "lighting" system **260** with an optical integrating cavity LED light fixture, having yet other elements to optically process the combined color light output, e.g. for stage or studio illumination. The system **260** includes an optical integrating cavity and LEDs similar to the example of FIG. **1**, and like reference numerals are used to identify the corresponding components.

In the example of FIG. **13**, the light fixture includes an optical integrating cavity **11**, formed by a dome **11** and a cover plate **15**. The surfaces of the dome **13** and cover **15** forming the interior surface(s) of the cavity **11** are diffusely reflective. One or more apertures **17**, in this example formed through the plate **15**, provide a light passage for transmission of reflected and integrated light outward from the cavity **11**. Materials, possible shapes, positions and orientations for the elements **11** to **17** have been discussed above. As in the earlier examples, the system **260** includes a number of LEDs **19** emitting light of different wavelengths into the cavity **11**. The possible combinations and positions of the LEDs **19** have been discussed in detail above, in relation to the earlier examples.

The LEDs **19** emit light of multiple light colors in the visible portion of the radiant energy spectrum into the interior of the optical integrating cavity **11**. Control of the amplitudes of the drive currents applied to the LEDs **19** controls the amount of each light color supplied into the cavity **11**. A number of the LEDs will be active, from initial start-up, whereas others may initially be inactive 'sleepers,' as discussed above. The cavity **11** integrates the various amounts of light of the different colors into a combined light of a desired color temperature for emission through the aperture **17**.

The system **260** also includes a control circuit **262** coupled to the LEDs **19** for establishing output intensity of radiant energy of each of the LED sources. The control circuit **262** typically includes a power supply circuit coupled to a source, shown as an AC power source **264**, although the power source **264** may be a DC power source. In either case, the circuit **262** may be adapted to process the voltage from the available source to produce the drive currents necessary for the LEDs **19**. The control circuit **262** includes an appropriate number of LED driver circuits, as discussed above relative to FIGS. **10** and **11**, for controlling the power applied to each of the individual LEDs **19** and thus the intensity of radiant energy supplied to the cavity **11** for each different type/color of light. Control of the intensity of emission of each of the LED sources sets a spectral characteristic of the combined radiant

energy emitted through the aperture **17** of the optical integrating cavity **11**, in this case, the color characteristic(s) of the visible light output.

The control circuit **262** may respond to a number of different input signals representing color characteristic settings, for example, as shown by the arrow in FIG. **16**. Feedback may also be provided by a temperature sensor (not shown in this example) or one or more color sensors **266**. The color sensor(s) **266** may be located in the cavity or in the element or elements for processing light emitted through the aperture **17**. However, in many cases, the plate **15** and/or dome **13** may pass some of the integrated light from the cavity, in which case, it is actually sufficient to place the color light sensor(s) **266** adjacent any such transmissive point on the outer wall that forms the cavity. In the example, the sensor **266** is shown attached to the plate **15**. Details of the control feedback have been discussed earlier, with regard to the circuitry in FIG. **10**.

The example of FIG. **13** utilizes a different arrangement for directing and processing the light after emission from the cavity **11** through the aperture **17**. This system **260** utilizes a collimator **253**, an adjustable iris **255** and an adjustable focus lens system **259**.

The collimator **253** may have a variety of different shapes, depending on the desired application and the attendant shape of the aperture **17**. For ease of discussion here, it is assumed that the elements shown are circular, including the aperture **17**. Hence, in the example, the collimator **253** comprises a substantially cylindrical tube, having a circular opening at a proximal end coupled to the aperture **17** of the optical integrating cavity **11**. The system **260** emits light toward a desired field of illumination via the circular opening at the distal end of the collimator **253**.

The interior surface of the collimator **253** is reflective. The reflective inner surface may be diffusely reflective or quasi-specular. Typically, in this embodiment, the interior surface of the deflector/collimator element **253** is specular. The tube forming the collimator **253** also supports a series of elements for optically processing the collimated and integrated light. Those skilled in the art will be familiar with the types of processing elements that may be used, but for purposes of understanding, it may be helpful to consider two specific types of such elements.

First, the tube forming the collimator **253** supports a variable iris. The iris **257** represents a secondary aperture, which effectively limits the output opening and thus the intensity of light that may be output by the system **260**. Although shown in the collimator tube, the iris may be mounted in or serve as the aperture **17**. A circuit **257** controls the size or adjustment of the opening of the iris **255**. In practice, the user activates the LED control circuit (see e.g. **21** in FIG. **1**) to set the characteristic (e.g. color temperature and ΔUV) of the output light, that is to say, so that the system **260** outputs light of a color characteristic desired for illumination of a particular subject. The overall intensity of the output light is then controlled through the circuit **257** and the iris **255**. Opening the iris **255** wider provides higher output intensity, whereas reducing the iris opening size decreases intensity of the light output.

In the system **260**, the tube forming the collimator **253** also supports one or more lens elements of the adjustable focusing system **259**, shown by way of example as two lenses **261** and **263**. Spacing between the lenses and/or other parameters of the lens system **259** are adjusted by a mechanism **265**, in response to a signal from a focus control circuit **267**. The elements **261** to **267** of the system **259** are shown here by way of example, to represent a broad class of elements that may be used to variably focus the emitted light in response to a control signal or digital control information or the like. If the

system **260** serves as a spot light, adjustment of the lens system **259** effectively controls the size of the spot on the person or other target object that the system illuminates. Those skilled in the art will recognize that other optical processing elements may be provided, such as a mask to control the shape of the illumination spot or various shutter arrangements for beam shaping.

Although shown as separate control circuits **257** and **267**, the functions of these circuits may be integrated together with each other or integrated into the circuit **262** that controls the operation of the LEDs **19**. For example, the system might use a single microprocessor or similar programmable microcontroller, which would run control programs for the LED drive currents, the iris control and the focus control.

The optical integrating cavity **11** and the LEDs **19** produce light of a precisely controlled composite color. As noted, control of the LED currents controls the amount of each color of light integrated into the output and thus the output light color. Control of the opening provided by the iris **255** then controls the intensity of the integrated light output of the system **260**. Control of the focusing by the system **259** enables control of the breadth of the light emissions and thus the spread of the area or region to be illuminated by the system **260**. Other elements may be provided to control beam shape. Professional production lighting applications for such a system include theater or studio lighting, for example, where it is desirable to control the color, intensity and the size of a spotlight beam. By connecting the LED control circuit **257**, the iris control circuit **257** and the focus control circuit **267** to a network similar to that in FIG. **12**, it becomes possible to control color, intensity and spot size from a remote network terminal, for example, at an engineer's station in the studio or theater.

FIGS. **14** and **15** show another fixture, but here adapted for use as a "wall-washer" illuminant lighting fixture. The fixture **330** includes an optical integrating cavity **331** having a diffusely reflective inner surface, as in the earlier examples. In this fixture, the cavity **331** again has a substantially rectangular cross-section. FIG. **15** is an isometric view of a section of the fixture, showing several of the components formed as a single extrusion of the desired cross section, but without any end-caps.

As shown in these figures, the fixture **330** includes several initially-active LEDs and several sleeper LEDs, generally shown at **339**, similar to those in the earlier examples. The LEDs emit controlled amounts of multiple colors of light into the optical integrating cavity **341** formed by the inner surfaces of a rectangular member **333**. A power source and control circuit similar to those used in the earlier examples provide the drive currents for the LEDs **339**, and in view of the similarity, the power source and control circuit are omitted from FIG. **21**, to simplify the illustration. One or more apertures **337**, of the shape desired to facilitate the particular lighting application, provide light passage for transmission of reflected and integrated light outward from the cavity **341**. Materials for construction of the cavity and the types of LEDs that may be used are similar to those discussed relative to the earlier illumination examples, although the number and intensities of the LEDs may be different, to achieve the output parameters desired for the particular wall-washer application.

The fixture **330** in this example (FIG. **14**) includes a deflector to further process and direct the light emitted from the aperture **337** of the optical integrating cavity **341**, in this case toward a wall, product or other subject somewhat to the left of and above the fixture **330**. The deflector is formed by two opposing panels **345a** and **345b** of the extruded body of the fixture. The panel **345a** is relatively flat and angled somewhat

to the left, in the illustrated orientation. Assuming a vertical orientation of the fixture as shown in FIG. **21**, the panel **345b** extends vertically upward from the edge of the aperture **337** and is bent back at about 90°. The shapes and angles of the panels **345a** and **345b** are chosen to direct the light to a particular area of a wall or product display that is to be illuminated, and may vary from application to application.

Each panel **345a**, **345b** has a reflective interior surface **349a**, **349b**. As in the earlier examples, all or portions of the deflector surfaces may be diffusely reflective, quasi-specular or specular. In the wall washer example, the deflector panel surface **349b** is diffusely reflective, and the deflector panel surface **349a** has a specular reflectivity, to optimize distribution of emitted light over the desired area illuminated by the fixture **330**.

The output opening of the deflector **345** may be covered with a grating, a plate or lens, although in the illustrated wall washer example, such an element is omitted.

FIG. **16** is a cross sectional view of another example of a wall washer type fixture **350**. The fixture **350** includes an optical integrating cavity **351** having a diffusely reflective inner surface, as in the earlier examples. In this fixture, the cavity **351** again has a substantially rectangular cross-section. As shown, the fixture **350** includes at least one white light source, represented by the white LED **355**. The fixture also includes several LEDs **359** of the various primary colors, typically red (R), green (G) and blue (B, not visible in this cross-sectional view). The LEDs **359** include both initially-active LEDs and sleeper LEDs, and the LEDs **359** are similar to those in the earlier examples. Again, the LEDs emit controlled amounts of multiple colors of light into the optical integrating cavity **351** formed by the inner surfaces of a rectangular member **353**. A power source and control circuit similar to those used in the earlier examples provide the drive currents for the LEDs **359**, and in this example, that same circuit controls the drive current applied to the white LED **355**. In view of the similarity, the power source and control circuit are omitted from FIG. **16**, to simplify the illustration.

One or more apertures **357**, of the shape desired to facilitate the particular lighting application, provide light passage for transmission of reflected and integrated light outward from the cavity **351**. The aperture may be laterally centered, as in the earlier examples; however, in this example, the aperture is off-center to facilitate a light-through to the left (in the illustrated orientation). Materials for construction of the cavity and the types of LEDs that may be used are similar to those discussed relative to the earlier illumination examples.

Here, it is assumed that the fixture **350** is intended to principally provide white light, for example, to illuminate a wall or product to the left and somewhat above the fixture. The presence of the white light source **355** increases the intensity of white light that the fixture produces. The control of the outputs of the primary color LEDs **359** allows the operator to adjust the color characteristics of the white light output, typically for desired illumination of different subjects.

As an example of operation, the fixture **350** may be used to illuminate products, e.g. as displayed in a store or the like, although it may be rotated or inverted for such a use. Different products may present a better impression if illuminated by white light having a color temperature and ΔUV . For example, fresh bananas may be more attractive to a potential customer when illuminated by light having more yellow tones. Soda sold in red cans, however, may be more attractive to a potential customer when illuminated by light having more red tones. For each product, the user can adjust the intensities of the light outputs from the LEDs **359** and/or **355** to produce

light that appears substantially white if observed directly by a human/customer but provides the desired highlighting tones and thereby optimizes lighting of the particular product that is on display.

The fixture **350** may have any desired output processing element(s), as discussed above with regard to various earlier examples. In the illustrated wall washer embodiment (FIG. **16**), the fixture **350** includes a deflector to further process and direct the light emitted from the aperture **357** of the optical integrating cavity **351**, in this case toward a wall or product somewhat to the left of and above the fixture **350**. The deflector is formed by two opposing panels **365a** and **365b** having reflective inner surfaces **365a** and **365b**. Although other shapes may be used to direct the light output to the desired area or region, the illustration shows the panel **365a**, **365b** as relatively flat panels set at somewhat different angle extending to the left, in the illustrated orientation. Of course, as for all the examples, the fixture may be turned at any desired angle or orientation to direct the light to a particular region or object to be illuminated by the fixture, in a given application.

As noted, each panel **365a**, **365b** has a reflective interior surface **369a**, **369b**. As in the earlier examples, all or portions of the deflector surfaces may be diffusely reflective, quasi-specular or specular. In the wall washer example, the deflector panel surface **369b** is diffusely reflective, and the deflector panel surface **369a** has a specular reflectivity, to optimize distribution of emitted light over the desired area of the wall illuminated by the fixture **350**. The output opening of the deflector **365** may be covered with a grating, a plate or lens, although in the illustrated wall washer example, such an element is omitted.

FIG. **17** is a cross-sectional view of another example of an optical integrating cavity type light fixture **370**. This example uses a deflector and lens to optically process the light output, and like the example of FIG. **16** the fixture **370** includes LEDs to produce various colors of light in combination with a white light source. The fixture **370** includes an optical integrating cavity **371**, formed by a dome and a cover plate, although other structures may be used to form the cavity. The surfaces of the dome and cover forming the interior surface(s) of the cavity **371** are diffusely reflective. One or more apertures **377**, in this example formed through the cover plate, provide a light passage for transmission of reflected and integrated light outward from the cavity **371**. Materials, sizes, orientation, positions and possible shapes for the elements forming the cavity and the types/numbers of LEDs have been discussed above.

As shown, the fixture **370** includes at least one white light source. Although the white light source could comprise one or more LEDs, as in the previous example (FIG. **16**), in this embodiment, the white light source comprises a lamp **375**. The lamp may be any convenient form of light bulb, such as an incandescent or fluorescent light bulb; and there may be one, two or more bulbs to produce a desired amount of white light. A preferred example of the lamp **375** is a quartz halogen light bulb. The fixture also includes several LEDs **379** of the various primary colors, typically red (R), green (G) and blue (B, not visible in this cross-sectional view), although additional colors may be provided or other color LEDs may be substituted for the RGB LEDs. Some LEDs will be active from initial operation. Other LEDs may be held in reserve as sleepers. The LEDs **379** are similar to those in the earlier examples, for emitting controlled amounts of multiple colors of light into the optical integrating cavity **371**.

A power source and control circuit similar to those used in the earlier examples provide the drive currents for the LEDs **359**. In view of the similarity, the power source and control

circuit for the LEDs are omitted from FIG. **17**, to simplify the illustration. The lamp **375** may be controlled by the same or similar circuitry, or the lamp may have a fixed power source.

The white light source **375** may be positioned at a point that is not directly visible through the aperture **377** similar to the positions of the LEDs **379**. However, for applications requiring relatively high white light output intensity, it may be preferable to position the white light source **375** to emit a substantial portion of its light output directly through the aperture **377**.

The fixture **370** may incorporate any of the further optical processing elements discussed above. For example, the fixture may include a variable iris and variable focus system, as in the embodiment of FIG. **13**. In the illustrated version, however, the fixture **370** includes a deflector **385** to further process and direct the light emitted from the aperture **377** of the optical integrating cavity **371**. The deflector **385** has a reflective interior surface **389** and expands outward laterally from the aperture, as it extends away from the cavity toward the region to be illuminated. In a circular implementation, the deflector **385** would be conical. Of course, for applications using other fixture shapes, the deflector may be formed by two or more panels of desired sizes and shapes. The interior surface **389** of the deflector **385** is reflective. As in the earlier examples, all or portions of the reflective deflector surface(s) may be diffusely reflective, quasi-specular, specular or combinations thereof.

As shown in FIG. **17**, a small opening at a proximal end of the deflector **385** is coupled to the aperture **377** of the optical integrating cavity **311**. The deflector **385** has a larger opening at a distal end thereof. The angle of the interior surface **389** and size of the distal opening of the deflector **385** define an angular field of radiant energy emission from the apparatus **370**.

The large opening of the deflector **385** is covered with a grating, a plate or the exemplary lens **387**. The lens **387** may be clear or translucent to provide a diffuse transmissive processing of the light passing out of the large opening. Prismatic materials, such as a sheet of micropism plastic or glass also may be used. In applications where a person may look directly at the fixture **370** from the illuminated region, it is preferable to use a translucent material for the lens **387**, to shield the observer from directly viewing the lamp **375**.

The fixture **370** thus includes a deflector **385** and lens **387**, for optical processing of the integrated light emerging from the cavity **371** via the aperture **377**. Of course, other optical processing elements may be used in place of or in combination with the deflector **385** and/or the lens **387**.

In the fixture of FIG. **17**, the lamp **375** provides substantially white light of relatively high intensity. Hence, most of the light output exhibits spectral characteristics of the lamp **375**. The integration of the light from the LEDs **379** in the cavity **375** supplements the light from the lamp **375** with additional colors, and the amounts of the different colors of light from the LEDs can be precisely controlled. Control of the light added from the LEDs can provide color correction (e.g. for age or variation of the lamp) and color adjustment for desired settings, as discussed above relative to the embodiment of FIG. **16**.

The exemplary systems discussed herein may have any size desirable for any particular application. A system may be relatively large, for lighting a room or product display or for providing spot or flood lighting. The system also may be relatively small, for example, to provide a small pinpoint of light. The system is particularly amenable to miniaturization. For example, instead of a plate to support the LEDs, the LEDs could be manufactured on a single chip. For some applica-

tions, it may also be desirable to form the integrating cavity on the chip or as part of the semiconductor package.

As shown by the discussion above, each of the various radiant energy emission systems with multiple color sources and an optical cavity to combine the energy from the sources provides a highly effective means to control the color produced by one or more fixtures. The output color characteristics are controlled simply by controlling the intensity of each of the sources supplying radiant energy to the chamber. The control of input intensity of the different wavelengths or colors of lights provides precise repeatable control of the combined light output. Settings to provide desired illumination of a particular subject, e.g. a desired white color temperature and difference from the black body curve, can be easily reused, transferred and/or replicated, whenever and wherever it is desired to illuminate the exact same subject or another instance of that subject.

While the foregoing has described what are considered to be the best mode and/or other examples, it is understood that various modifications may be made therein and that the subject matter disclosed herein may be implemented in various forms and examples, and that they may be applied in numerous applications, only some of which have been described herein. It is intended by the following claims to claim any and all modifications and variations that fall within the true scope of the present concepts.

What is claimed is:

1. A method of illuminating a subject, comprising:

generating a variable amount of light of a first wavelength and a variable amount of light of a second wavelength, wherein the second wavelength is different from the first wavelength;

optically combining the light of the first wavelength with the light of the second wavelength;

illuminating the subject with the combined light;

adjusting the amount of the light of the first wavelength or the amount of the light of the second wavelength, to achieve a color characteristic of a desired illumination of the subject with the combined light;

recording the amount of the light of the first wavelength and the amount of the light of the second wavelength contained in the combined light used to achieve the desired illumination of the subject;

setting a lighting system to generate the recorded amount of the light of the first wavelength and to generate the recorded amount of the light of the second wavelength, wherein the setting step comprises:

(1) setting an intensity of illumination of a source of the light of the first wavelength for the lighting system to the recorded amount of the light of the first wavelength; and

(2) setting an intensity of illumination of a source of the light of the second wavelength for the lighting system to the recorded amount of the light of the second wavelength,

wherein the sources comprise light emitting diodes of different colors;

operating the lighting system to generate the set recorded amounts of light of the first and second wavelengths;

optically combining the light of the first and second wavelengths generated by the lighting system to produce a combined light output corresponding to the desired illumination, wherein the step of optically combining the light of the first and second wavelengths generated by the lighting system, comprises:

(a) diffusely reflecting the light of the first and second wavelengths generated by the lighting system within a cavity; and

(b) emitting the light of the first and second wavelengths through an aperture of the cavity as the combined light output; and

irradiating the subject or a similar subject with the combined light output from the lighting system, to achieve the desired illumination of the subject using the lighting system.

2. A method of illuminating a subject, comprising:

generating a variable amount of light of a first wavelength and a variable amount of light of a second wavelength, wherein the second wavelength is different from the first wavelength;

optically combining the light of the first wavelength with the light of the second wavelength;

illuminating the subject with the combined light;

adjusting the amount of the light of the first wavelength or the amount of the light of the second wavelength, to achieve a color characteristic of a desired illumination of the subject with the combined light;

recording the amount of the light of the first wavelength and the amount of the light of the second wavelength contained in the combined light used to achieve the desired illumination of the subject;

setting a lighting system to generate the recorded amount of the light of the first wavelength and to generate the recorded amount of the light of the second wavelength;

operating the lighting system to generate the set recorded amounts of light of the first and second wavelengths;

optically combining the light of the first and second wavelengths generated by the lighting system to produce a combined light output corresponding to the desired illumination; and

irradiating the subject or a similar subject with the combined light output from the lighting system, to achieve the desired illumination of the subject using the lighting system,

wherein the desired illumination of the subject using the lighting system provides substantially white light of a selected color temperature having a difference in chromaticity from the selected temperature on the black body curve.

3. A method of illuminating a subject, comprising:

generating a variable amount of light of a first wavelength and a variable amount of light of a second wavelength, wherein the second wavelength is different from the first wavelength;

optically combining the light of the first wavelength with the light of the second wavelength;

illuminating the subject with the combined light;

adjusting the amount of the light of the first wavelength or the amount of the light of the second wavelength, to achieve a color characteristic of a desired illumination of the subject with the combined light;

recording the amount of the light of the first wavelength and the amount of the light of the second wavelength contained in the combined light used to achieve the desired illumination of the subject, wherein the recording of the amount of the light of the first wavelength and the amount of the light of the second wavelength contained in the combined light used to achieve the desired illumination of the subject comprises recording chromaticity coordinates corresponding to the desired illumination;

31

setting a lighting system to generate the recorded amount of the light of the first wavelength and to generate the recorded amount of the light of the second wavelength; operating the lighting system to generate the set recorded amounts of light of the first and second wavelengths; 5
 optically combining the light of the first and second wavelengths generated by the lighting system to produce a combined light output corresponding to the desired illumination; and
 irradiating the subject or a similar subject with the combined light output from the lighting system, to achieve the desired illumination of the subject using the lighting system. 10

4. A method of illuminating a subject, comprising:
 generating a variable amount of light of a first wavelength and a variable amount of light of a second wavelength, wherein the second wavelength is different from the first wavelength; 15
 optically combining the light of the first wavelength with the light of the second wavelength; 20
 illuminating the subject with the combined light;
 adjusting the amount of the light of the first wavelength or the amount of the light of the second wavelength, to achieve a color characteristic of a desired illumination of the subject with the combined light; 25
 recording the amount of the light of the first wavelength and the amount of the light of the second wavelength contained in the combined light used to achieve the desired illumination of the subject, wherein the recording of the amount of the light of the first wavelength and the amount of the light of the second wavelength contained in the combined light used to achieve the desired illumination of the subject comprises recording proportional amounts for three primary colors, for producing a chromaticity corresponding to the desired illumination; 35
 setting a lighting system to generate the recorded amount of the light of the first wavelength and to generate the recorded amount of the light of the second wavelength;
 operating the lighting system to generate the set recorded amounts of light of the first and second wavelengths; 40
 optically combining the light of the first and second wavelengths generated by the lighting system to produce a combined light output corresponding to the desired illumination; and
 irradiating the subject or a similar subject with the combined light output from the lighting system, to achieve the desired illumination of the subject using the lighting system. 45

5. A method of illuminating a subject, comprising:
 generating a variable amount of light of a first wavelength and a variable amount of light of a second wavelength, wherein the second wavelength is different from the first wavelength; 50
 optically combining the light of the first wavelength with the light of the second wavelength; 55
 illuminating the subject with the combined light;
 adjusting the amount of the light of the first wavelength or the amount of the light of the second wavelength, to achieve a color characteristic of a desired illumination of the subject with the combined light; 60
 recording the amount of the light of the first wavelength and the amount of the light of the second wavelength contained in the combined light used to achieve the desired illumination of the subject;
 setting a lighting system to generate the recorded amount of the light of the first wavelength and to generate the recorded amount of the light of the second wavelength; 65

32

operating the lighting system to generate the set recorded amounts of light of the first and second wavelengths; optically combining the light of the first and second wavelengths generated by the lighting system to produce a combined light output corresponding to the desired illumination; 5
 irradiating the subject or a similar subject with the combined light output from the lighting system, to achieve the desired illumination of the subject using the lighting system;
 sensing color of the combined light of the lighting system; and
 adjusting the operation of the lighting system to generate the set recorded amounts of light, in response to the sensed color. 10

6. A method of illuminating a subject, comprising:
 generating a variable amount of light of a first wavelength and a variable amount of light of a second wavelength, wherein the second wavelength is different from the first wavelength; 15
 optically combining the light of the first wavelength with the light of the second wavelength; 20
 illuminating the subject with the combined light;
 adjusting the amount of the light of the first wavelength or the amount of the light of the second wavelength, to achieve a color characteristic of a desired illumination of the subject with the combined light; 25
 recording the amount of the light of the first wavelength and the amount of the light of the second wavelength contained in the combined light used to achieve the desired illumination of the subject;
 setting a lighting system to generate the recorded amount of the light of the first wavelength and to generate the recorded amount of the light of the second wavelength; 30
 operating the lighting system to generate the set recorded amounts of light of the first and second wavelengths;
 optically combining the light of the first and second wavelengths generated by the lighting system to produce a combined light output corresponding to the desired illumination; and
 irradiating the subject or a similar subject with the combined light output from the lighting system, to achieve the desired illumination of the subject using the lighting system, 35
 wherein the step of operating the lighting system to generate the set recorded amounts of light of the first and second wavelengths includes activating at least one initially inactive source of light of one of the wavelengths. 40

7. A method of illuminating a subject with light of a desired color characteristic, comprising:
 setting a first amount for light of a first wavelength; 45
 generating light of the first wavelength from a first source, in a first intensity corresponding to the first set amount; 50
 setting a second amount for light of a second wavelength; 55
 generating light of the second wavelength from a second source, in a second intensity corresponding to the second set amount,
 wherein the first and second sources comprise first and second light emitting diodes, of different colors, the second wavelength is different from the first wavelength, and the first and second set amounts correspond to the desired color characteristic for the illumination of the subject; 60
 diffusely reflecting the generated light of the first and second wavelengths from the first and second sources within a cavity, to produce combined light containing 65

33

amounts of light of the first and second wavelengths in proportion to the first and second set amounts; and emitting at least a portion of the combined light through an aperture of the cavity to illuminate the subject with light of the desired color characteristic.

8. A method of illuminating a subject with light of a desired color characteristic, comprising:

setting a first amount for light of a first wavelength; generating light of the first wavelength from a first source, in a first intensity corresponding to the first set amount; setting a second amount for light of a second wavelength; generating light of the second wavelength from a second source, in a second intensity corresponding to the second set amount,

wherein the second wavelength is different from the first wavelength, and the first and second set amounts correspond to the desired color characteristic for the illumination of the subject;

diffusely reflecting the generated light of the first and second wavelengths from the first and second sources within a cavity, to produce combined light containing amounts of light of the first and second wavelengths in proportion to the first and second set amounts;

emitting at least a portion of the combined light through an aperture of the cavity to illuminate the subject with light of the desired color characteristic; and

determining the first and second amounts so as to provide the color characteristic of the desired illumination of the subject with the combined light, before performing the setting and generating steps.

9. The method of claim 8, wherein the combined light provides substantially white light of a selected color temperature with a difference in chromaticity from the selected temperature on the black body curve.

10. The method of claim 9, wherein the determining step comprises recording chromaticity coordinates representing the color characteristic of the desired illumination, for use in setting the first amount of light of the first wavelength and the second amount of light of the second wavelength.

11. The method of claim 9, wherein the determining step comprises recording a first color intensity for the first wavelength and a second color intensity for the second wavelength, for producing the color characteristic of the desired illumination.

12. A method of illuminating a subject with light of a desired color characteristic, comprising:

setting a first amount for light of a first wavelength; generating light of the first wavelength from a first source, in a first intensity corresponding to the first set amount; setting a second amount for light of a second wavelength; generating light of the second wavelength from a second source, in a second intensity corresponding to the second set amount,

wherein the second wavelength is different from the first wavelength, and the first and second set amounts correspond to the desired color characteristic for the illumination of the subject;

diffusely reflecting the generated light of the first and second wavelengths from the first and second sources within a cavity, to produce combined light containing amounts of light of the first and second wavelengths in proportion to the first and second set amounts;

34

emitting at least a portion of the combined light through an aperture of the cavity to illuminate the subject with light of the desired color characteristic;

sensing color of the combined light of the lighting system; and

controlling intensity of light of the first wavelength generated from the first source or intensity of light of the second wavelength generated from the second source, to generate the set amount of light of at least one of the wavelengths, in response to the sensed color.

13. A method of illuminating a subject with light of a desired color characteristic, comprising:

setting a first amount for light of a first wavelength; generating light of the first wavelength from a first source, in a first intensity corresponding to the first set amount; setting a second amount for light of a second wavelength; generating light of the second wavelength from a second source, in a second intensity corresponding to the second set amount,

wherein the second wavelength is different from the first wavelength, and the first and second set amounts correspond to the desired color characteristic for the illumination of the subject;

diffusely reflecting the generated light of the first and second wavelengths from the first and second sources within a cavity, to produce combined light containing amounts of light of the first and second wavelengths in proportion to the first and second set amounts; and

emitting at least a portion of the combined light through an aperture of the cavity to illuminate the subject with light of the desired color characteristic,

wherein at least one of the generating steps includes activating at least one initially inactive source of light of one of the wavelengths.

14. A method of illuminating a subject with light of a desired color characteristic, comprising:

determining settings relating to amounts of three colors of light for providing the desired color characteristic for illumination of the subject;

recording data corresponding to the determined settings; transferring the recorded data to a lighting system for use in illuminating the subject;

responsive to the transferred data, generating light of the three colors in amounts corresponding to the determined settings;

diffusely reflecting the generated light of the three colors within an optical integrating cavity, to produce combined light containing the three colors of light in amounts proportional to the determined settings; and emitting at least a portion of the combined light through a passage through a wall of the optical integrating cavity to illuminate the subject with light of the desired color characteristic, for human observation of the illuminated subject.

15. The method of claim 14, wherein the combined light is substantially white.

16. The method of claim 14, wherein the three colors of light comprise three primary colors of light.

17. The method of claim 14, wherein the three colors of light comprise white light and two or more primary colors of light.

* * * * *