



US007300182B2

(12) **United States Patent**
Mazzochette

(10) **Patent No.:** **US 7,300,182 B2**
(45) **Date of Patent:** **Nov. 27, 2007**

(54) **LED LIGHT SOURCES FOR IMAGE PROJECTION SYSTEMS**

5,482,898 A	1/1996	Marrs	437/216
5,485,037 A	1/1996	Marrs	257/712
5,581,876 A	12/1996	Prabhu et al.	29/851
5,725,808 A	3/1998	Tormey et al.	252/514
5,745,624 A	4/1998	Chan et al.	385/91
5,841,244 A	11/1998	Hamilton et al.	
5,847,935 A	12/1998	Thaler et al.	361/761

(75) Inventor: **Joseph Mazzochette**, Cherry Hill, NJ (US)

(73) Assignee: **Lamina Lighting, Inc.**, Westampton, NJ (US)

(*) Notice: Subject to any disclaimer, the term of this patent is extended or adjusted under 35 U.S.C. 154(b) by 93 days.

(Continued)

FOREIGN PATENT DOCUMENTS

(21) Appl. No.: **11/030,648** JP 2000-294701 10/2000 257/712

(22) Filed: **Jan. 6, 2005**

(65) **Prior Publication Data**

US 2005/0174544 A1 Aug. 11, 2005

Related U.S. Application Data

(63) Continuation-in-part of application No. 10/638,579, filed on Aug. 11, 2003, now Pat. No. 7,095,053.

(60) Provisional application No. 60/467,857, filed on May 5, 2003.

(51) **Int. Cl.**

G03B 21/16 (2006.01)

H01L 27/15 (2006.01)

(52) **U.S. Cl.** **362/294**; 353/52; 257/81

(58) **Field of Classification Search** 362/294, 362/253, 234; 353/52, 55, 56; 352/203, 352/198; 257/81, 98, 99

See application file for complete search history.

(56) **References Cited**

U.S. PATENT DOCUMENTS

3,711,789 A	1/1973	Dierschke	
4,886,709 A	12/1989	Sasame et al.	428/552
4,935,655 A	6/1990	Ebner	
5,117,281 A	5/1992	Katsuraoka	357/81
5,122,781 A	6/1992	Saubolle	340/473
5,140,220 A	8/1992	Hasegawa	313/512

Primary Examiner—Sandra O’Shea
Assistant Examiner—Bao Q. Truong
(74) Attorney, Agent, or Firm—Darby & Darby

(57) **ABSTRACT**

In accordance with the invention a light source for an image projection system comprises one or more LEDs packaged for high temperature operation. Advantageously, the LED die are disposed on a package comprising a ceramic coated metal base including one or more underlying thermal connection pads, and underlying electrical connection pads, each LED die thermally coupled through the metal base to a thermal connection pad and electrically coupled to electrical connection pads. The LED can be mounted directly on the metal of the base or on a thin coating of electrical insulator on the metal. Arrays of LED die thus packaged are advantageously fabricated by the low temperature co-fired ceramic-on-metal technique (LTTC-M) and can be referred to as LTTC-M packaged arrays. The LEDs are advantageously mounted in an array of cavities having tapered sides to reflect light from the LEDs. The high temperature LED light sources can substitute for HID lamps in a variety of front and rear projection systems and displays. They are particularly useful for rear projection systems.

28 Claims, 15 Drawing Sheets

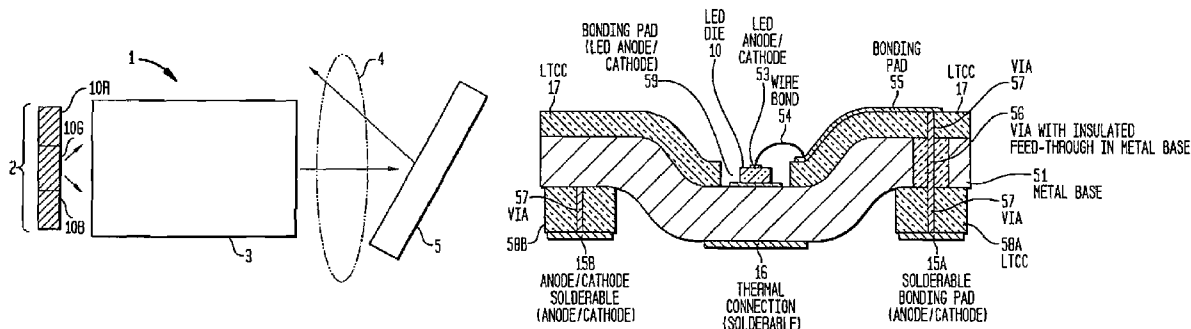

U.S. PATENT DOCUMENTS

5,857,767 A	1/1999	Hochstein	362/294	6,793,374 B2	9/2004	Begemann	
5,953,203 A	9/1999	Tormey et al.	361/313	6,982,829 B1 *	1/2006	Berman	359/495
5,977,567 A	11/1999	Verdiell	257/99	7,098,483 B2 *	8/2006	Mazzochette et al.	257/81
6,016,038 A	1/2000	Mueller et al.		2001/0032985 A1	10/2001	Bhat et al.	
6,045,240 A	4/2000	Hochstein	362/294	2002/0004251 A1	1/2002	Roberts et al.	438/26
6,220,722 B1	4/2001	Begemann	362/231	2002/0034834 A1	3/2002	Verdiell	438/22
6,224,216 B1 *	5/2001	Parker et al.	353/31	2002/0163006 A1	11/2002	Yoganandan et al.	257/81
6,259,846 B1	7/2001	Roach et al.		2002/0175621 A1	11/2002	Song et al.	313/315
6,318,886 B1	11/2001	Stopa et al.		2002/0176250 A1	11/2002	Bohler et al.	362/236
6,325,524 B1	12/2001	Weber et al.	362/245	2003/0010993 A1	1/2003	Makamura et al.	
6,376,268 B1	4/2002	Verdiell	438/26	2003/0025465 A1	2/2003	Swanson et al.	
6,428,189 B1	8/2002	Hochstein	362/373	2003/0057421 A1	3/2003	Chen	257/79
6,455,930 B1	9/2002	Palanisamy et al.	257/706	2004/0026706 A1	2/2004	Bogner et al.	257/99
6,480,389 B1	11/2002	Shie et al.	361/707	2004/0150995 A1	8/2004	Coushaine et al.	
6,483,623 B1	11/2002	Maruyama	359/180	2004/0222433 A1	11/2004	Mazzochette et al.	
6,518,502 B2	2/2003	Hammond et al.	174/52.4	2004/0233872 A1	11/2004	Dubuc	
6,634,750 B2	10/2003	Neal et al.	351/211	2005/0029635 A1	2/2005	Mazzochette et al.	
6,634,770 B2	10/2003	Cao	362/294	2005/0088625 A1 *	4/2005	Imade	353/31
6,670,751 B2	12/2003	Song et al.		2005/0189557 A1	9/2005	Mazzochette et al.	
6,680,461 B2	1/2004	Watanabe et al.		2005/0225222 A1	10/2005	Mazzochette et al.	
6,692,252 B2	2/2004	Scott	433/29				

* cited by examiner

FIG. 1

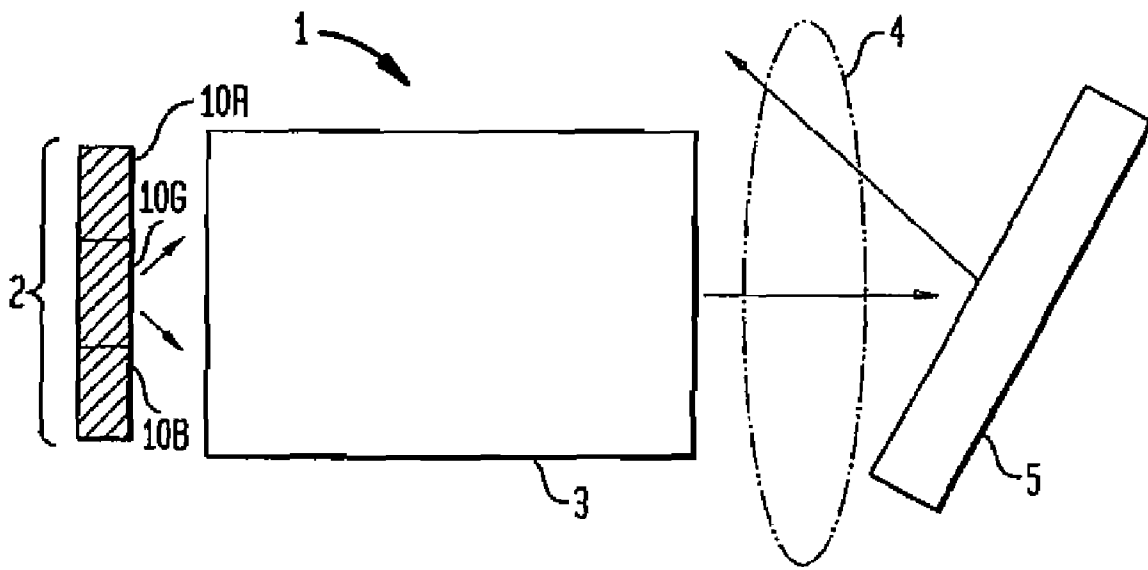

FIG. 2A

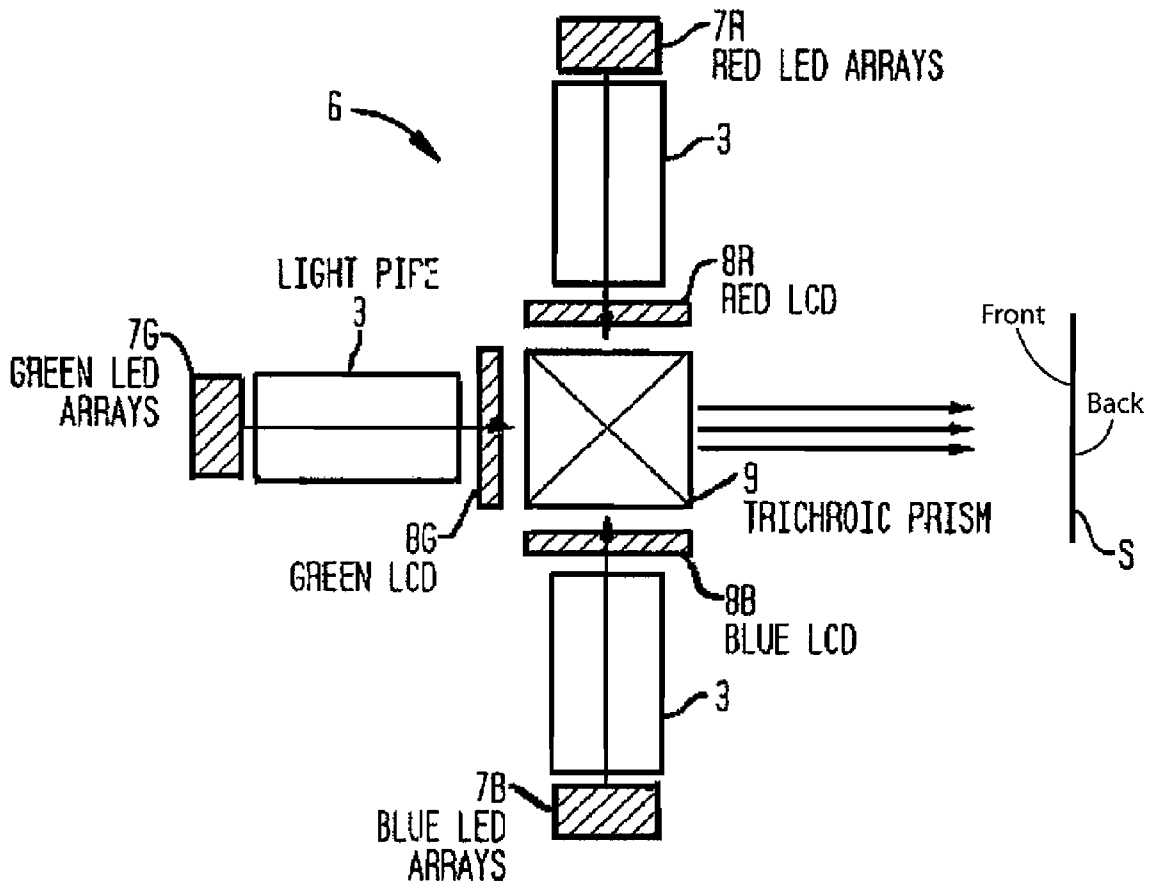

FIG. 2B

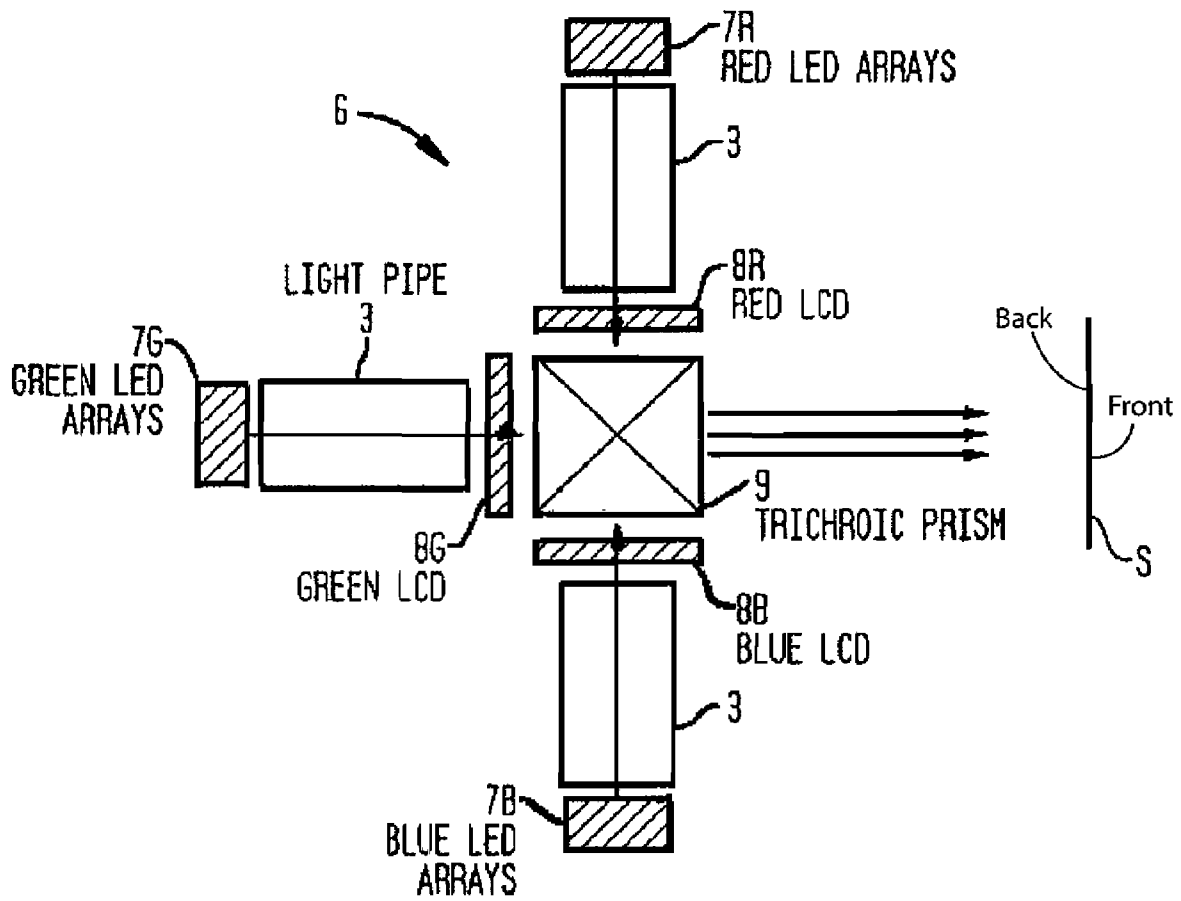

FIG. 3

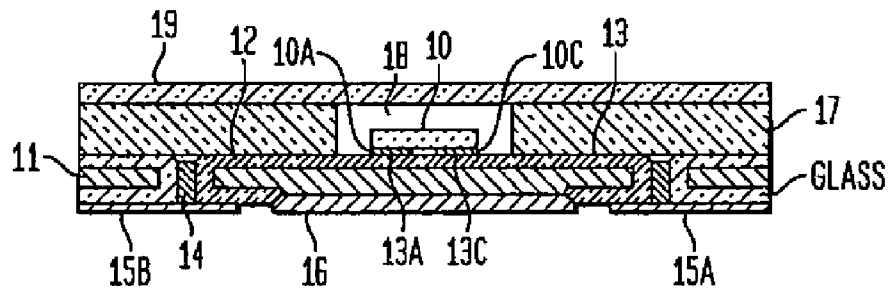

FIG. 4

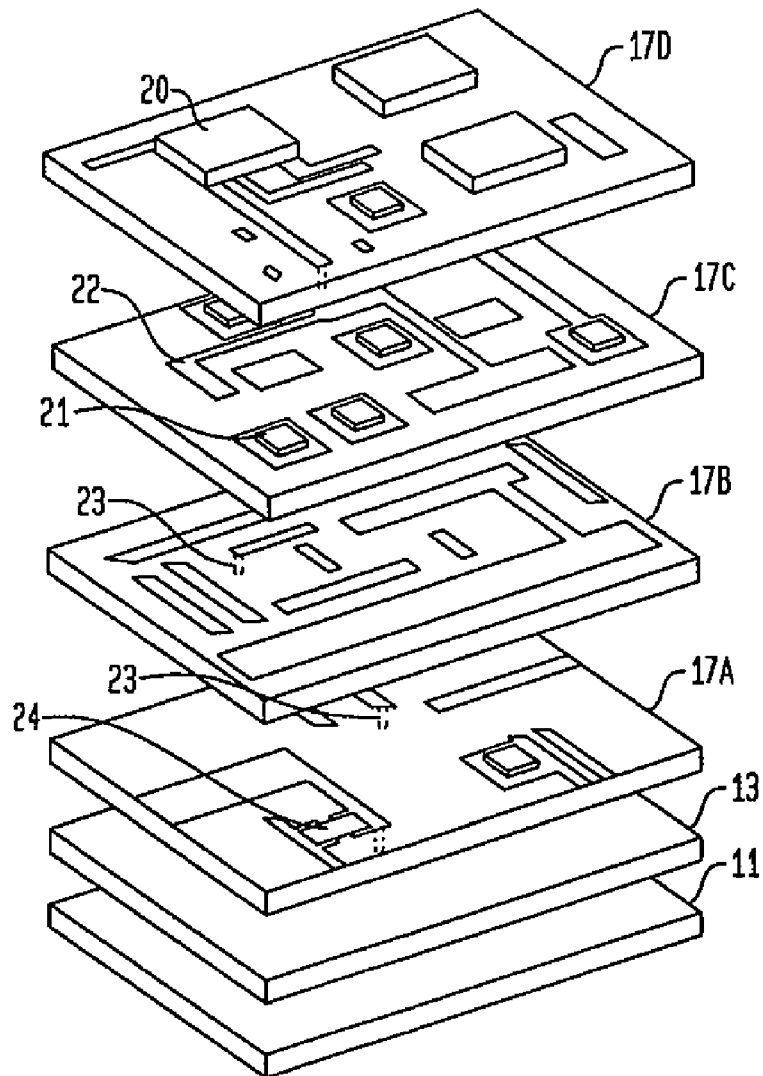

FIG. 5A

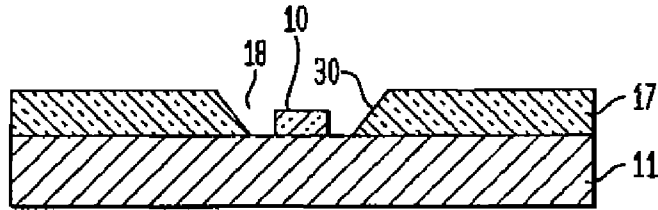

FIG. 5B

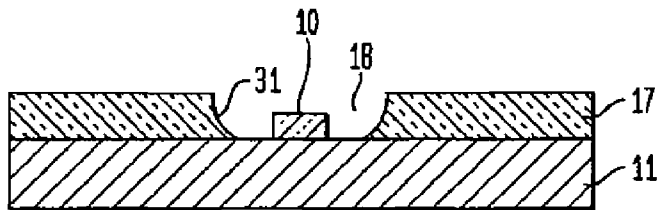

FIG. 6

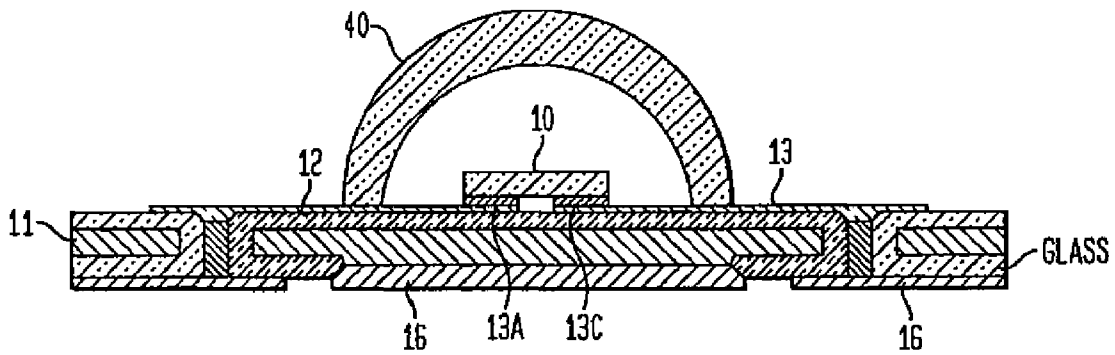

FIG. 7

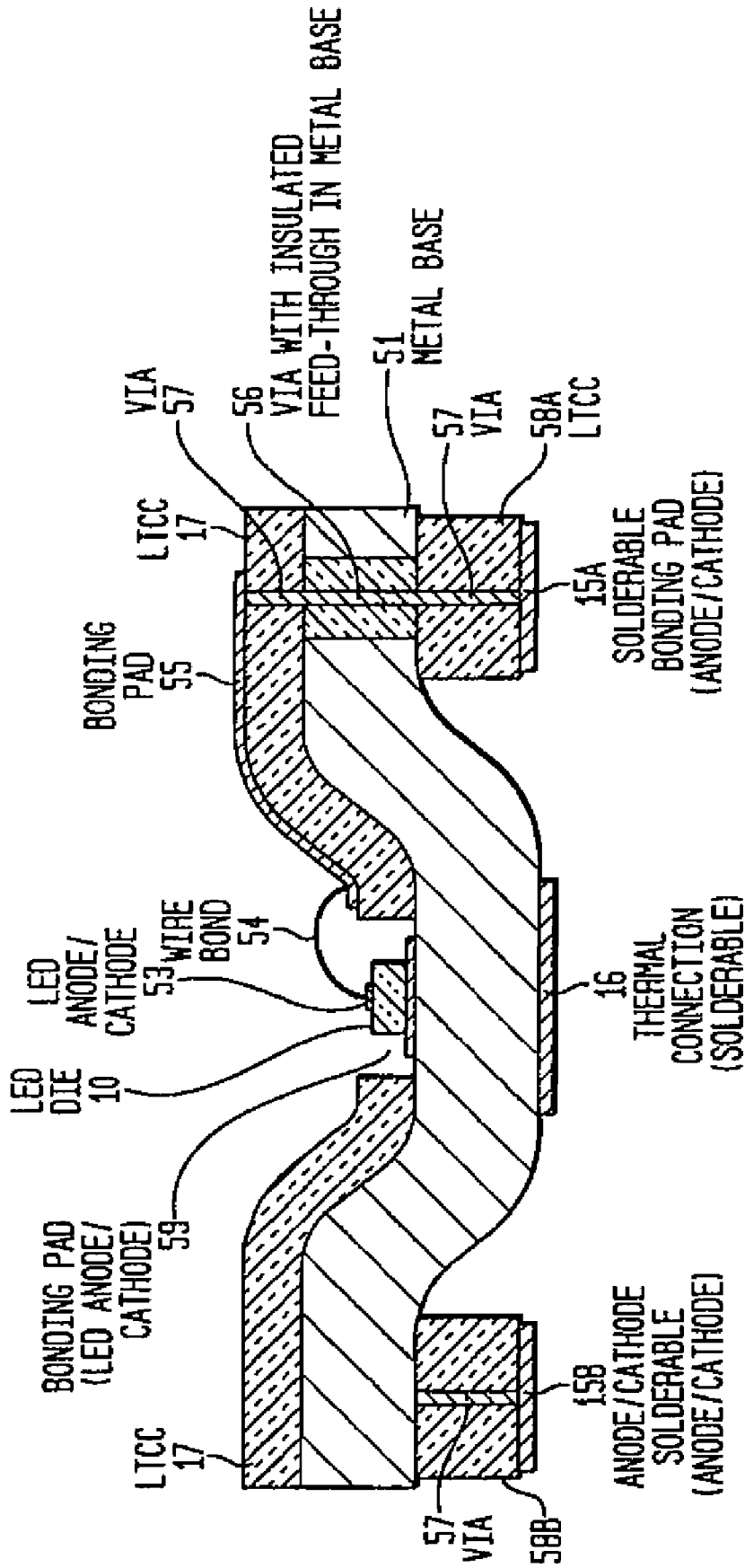

FIG. 8

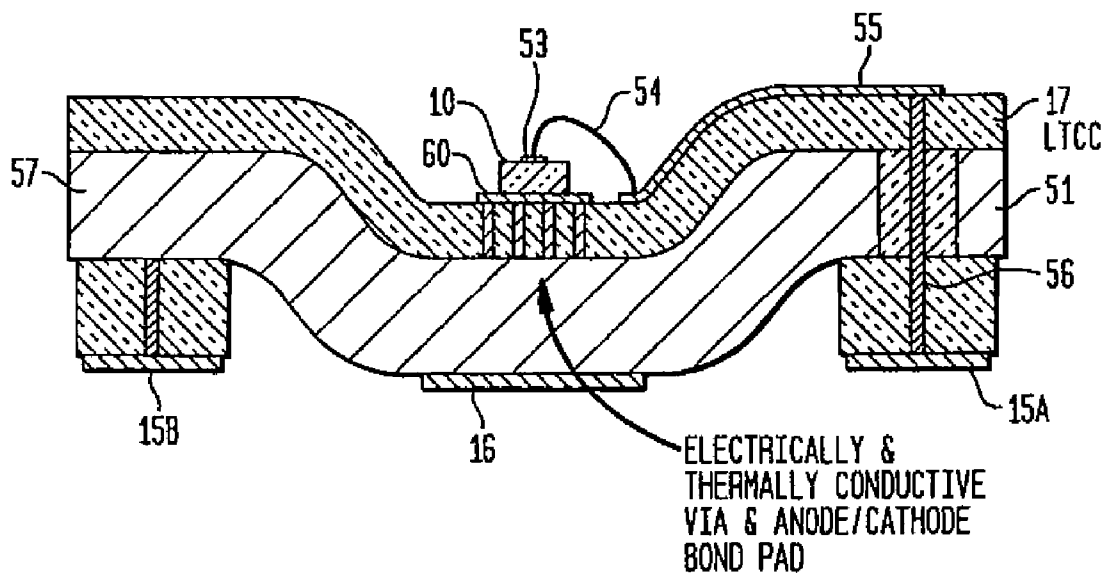

FIG. 9

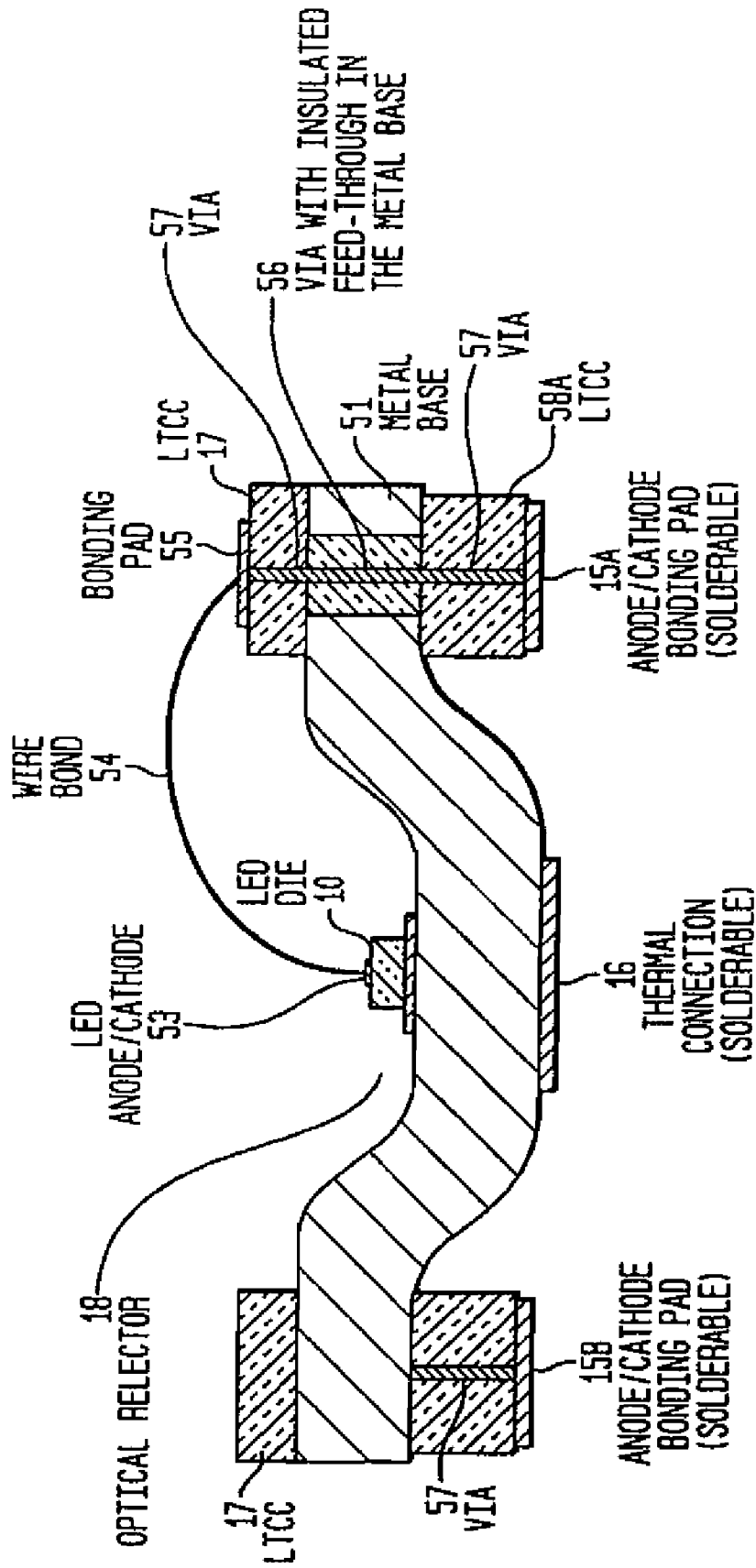

FIG. 10

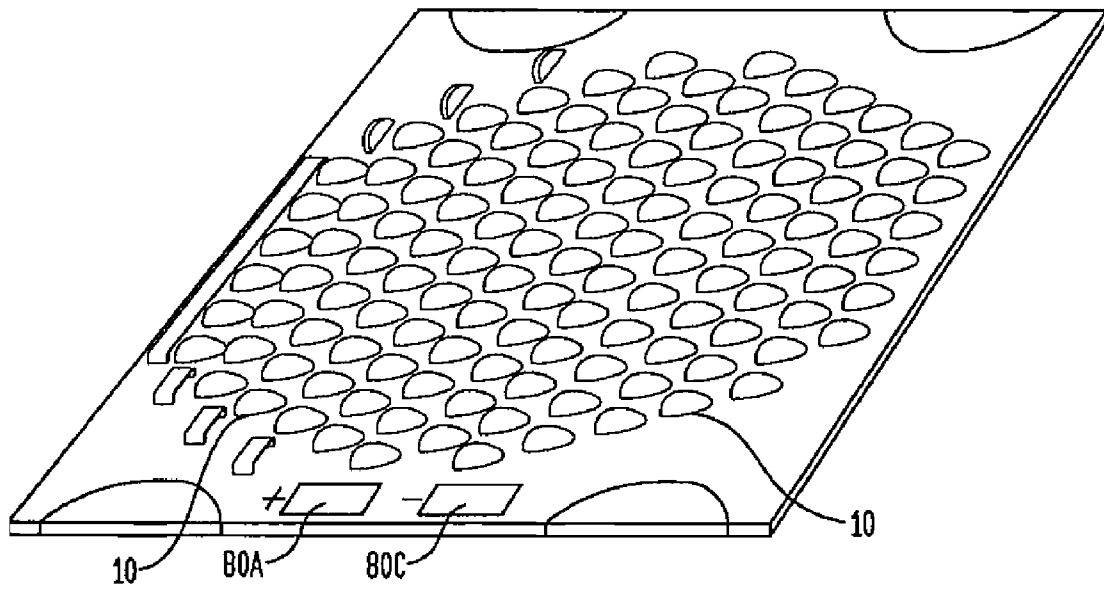

FIG. 11

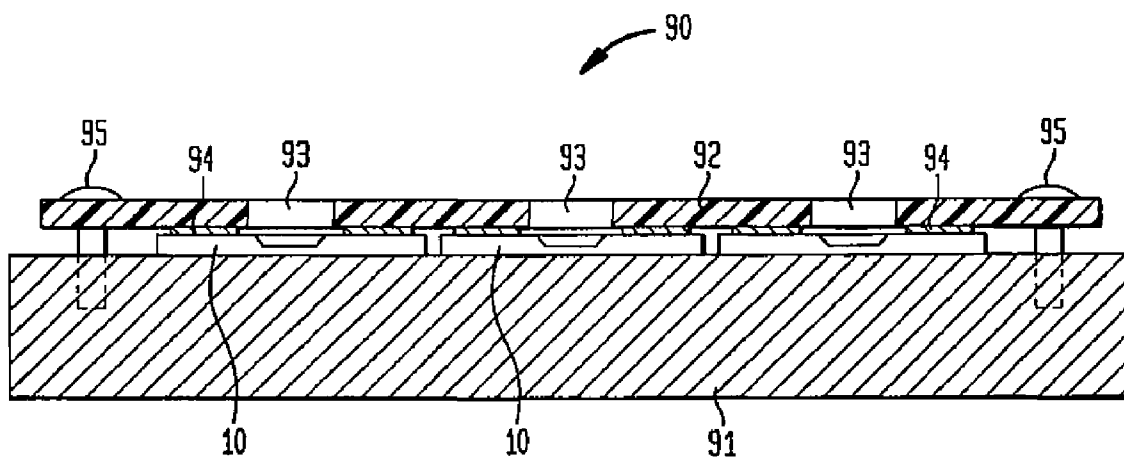

FIG. 12

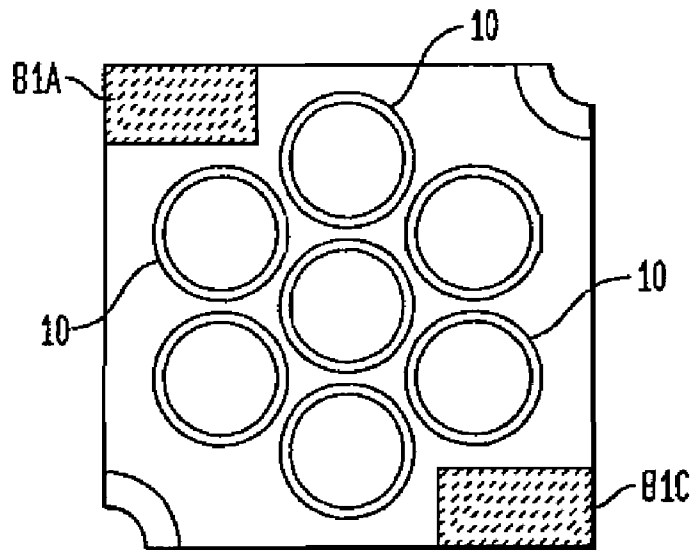

FIG. 13

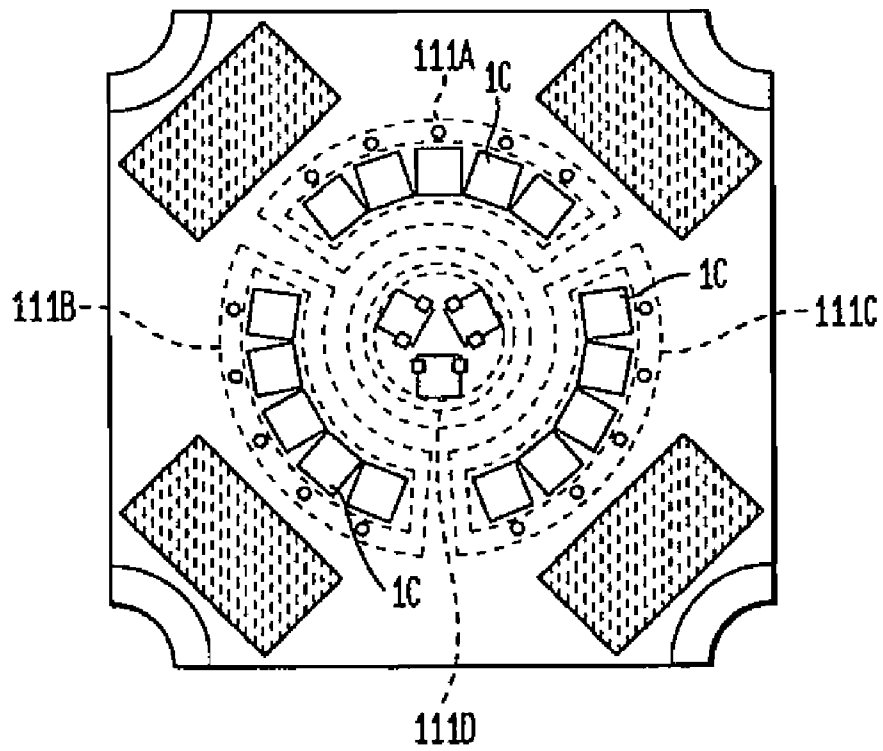

FIG. 14

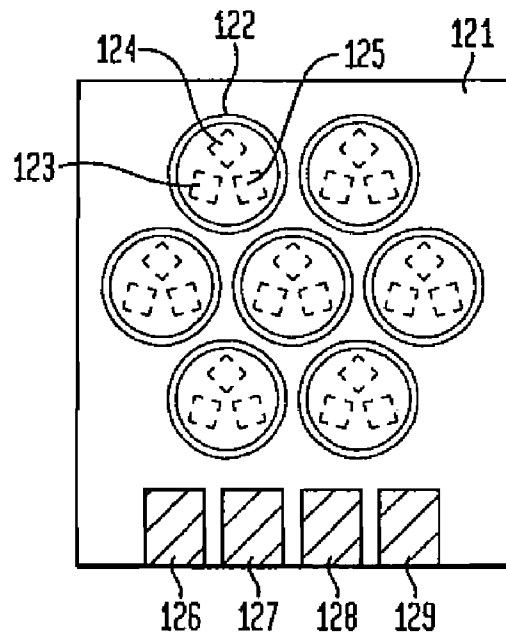

FIG. 15

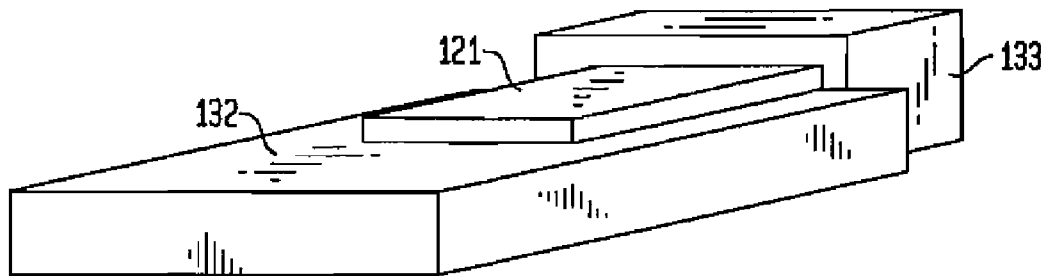

FIG. 16

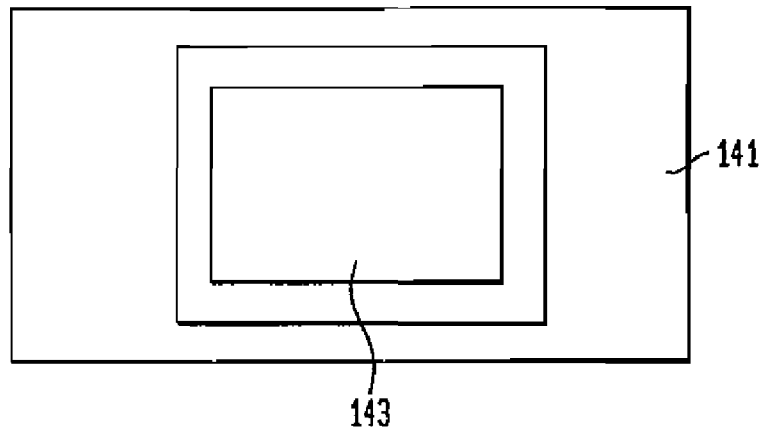

FIG. 17

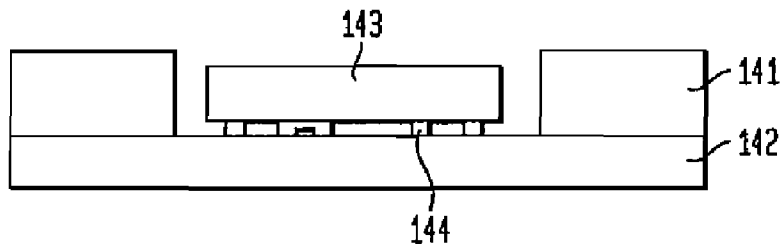

FIG. 18

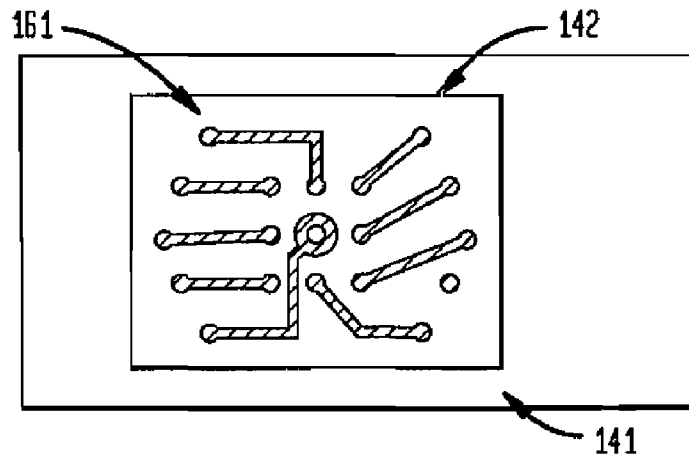

FIG. 19

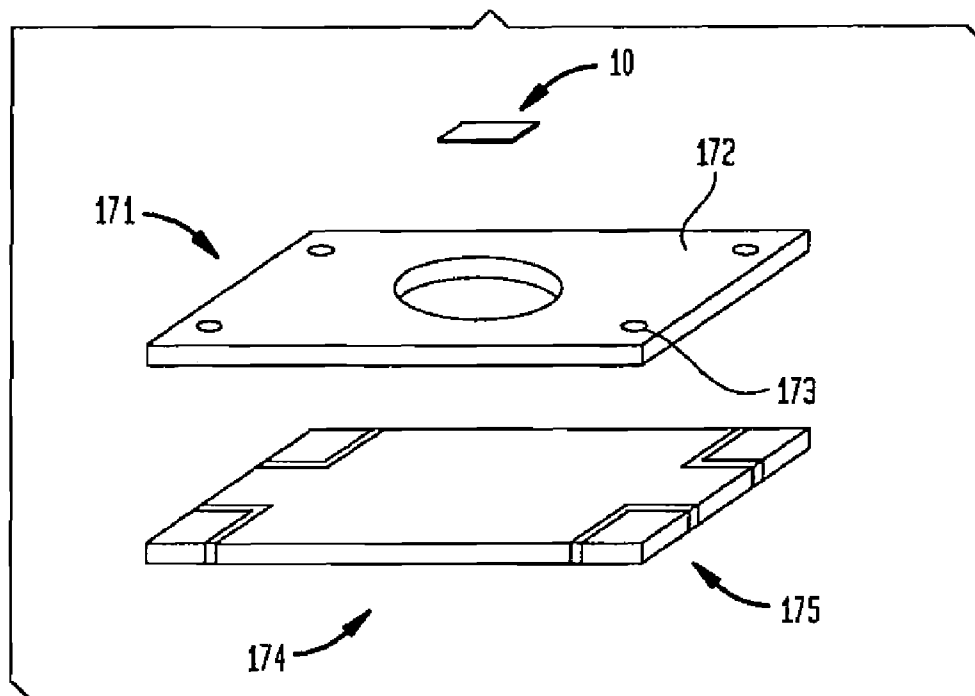

FIG. 20

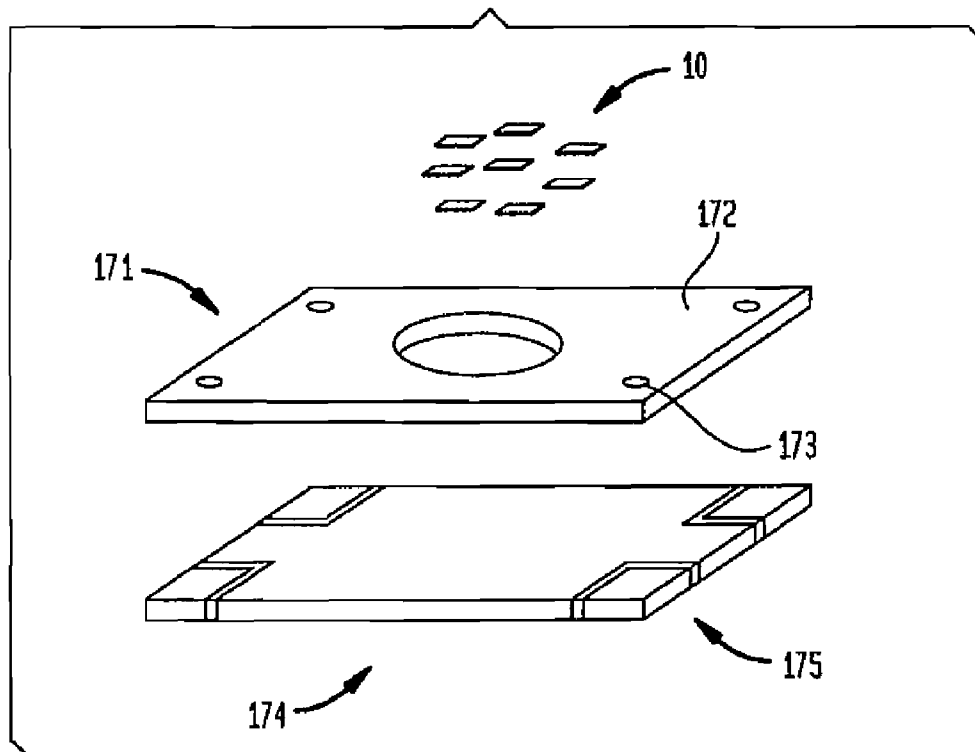
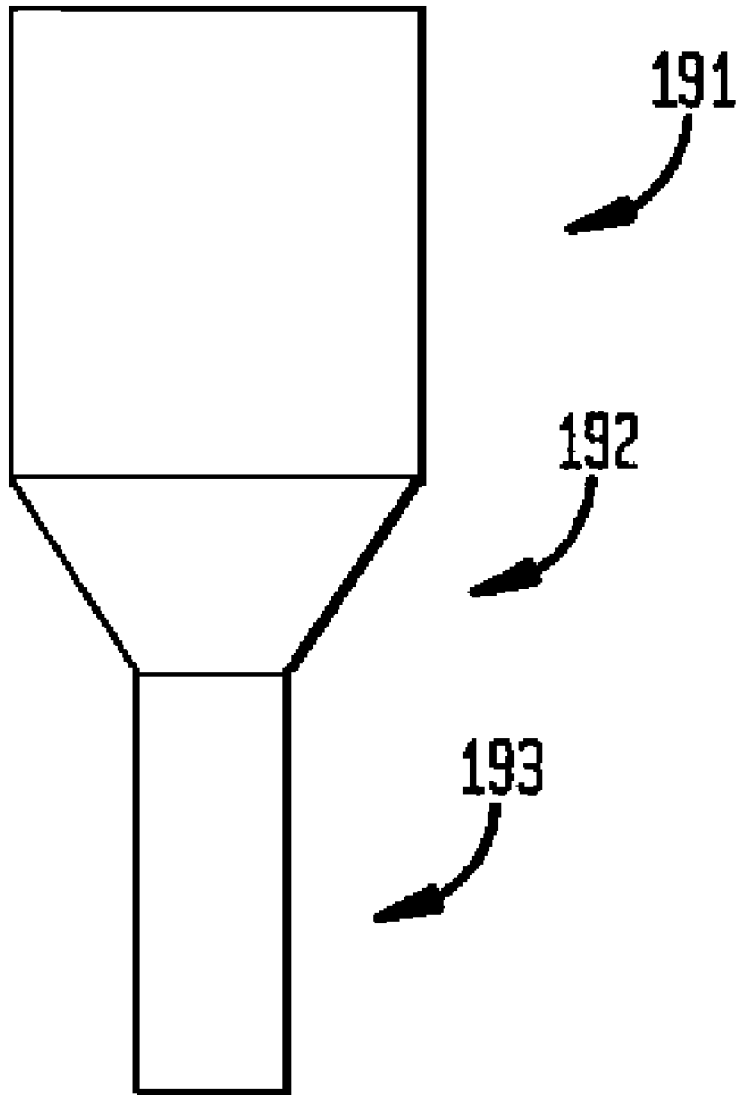

FIG. 21

190



1

LED LIGHT SOURCES FOR IMAGE PROJECTION SYSTEMS

CROSS REFERENCE TO RELATED APPLICATIONS

This application is a continuation-in-part of U.S. application Ser. No. 10/638,579 "Light Emitting Diodes Packaged For High Temperature Operation" filed by Joseph Mazzochette et al. on Aug. 11, 2003 now U.S. Pat. No. 7,095,053 which, in turn, claims the benefit of U.S. Provisional Application Ser. No. 60/467,857, of the same title, filed May 5, 2003. The '579 and '857 applications are incorporated herein by reference.

FIELD OF THE INVENTION

This invention relates to image projection systems and, in particular, to LED light sources for image projection systems and to systems employing such sources.

BACKGROUND OF THE INVENTION

Image projection systems are important communication tools. They permit the conversion of digital or analog information into visual images that can be viewed by audiences as small as one and as large as several thousand.

While there are a wide variety of image projection systems varying from simple slide projectors to Imax theaters, most such systems use high intensity discharge lamps (HID lamps) to project an image. Unfortunately, HID lamps present serious problems in use.

A typical HID lamp comprises a pair of electrodes in a glass bulb (typically fused quartz) filled with metallic vapor. A voltage applied between the electrodes creates an arc of rapidly moving electrons between the electrodes. When the electrons collide with atoms of the metallic vapor, the collisions temporarily excite the atoms, and when the atoms drop back to their unexcited states, they emit light. Because of the ease with which mercury can be vaporized, it is widely used in HID lamps. To obtain an adequate density of vapor atoms, the mercury must typically be heated to relatively high temperature (hundreds of degrees Centigrade) and high pressure (hundreds of PSI). Indeed bulb surface temperatures in HID lamps can reach 590° C., and the lamps can reach pressures of 450 PSI.

The heat and pressure in HID bulbs present a number of operational difficulties. The heat presents risks of fire, burn injury to users and heat damage to nearby components. The pressure presents a risk of bulb explosion and a consequent spewing of hot fragments and toxic mercury. Achieving the necessary heat takes time, preventing a projector from rapid display, and once the needed heat is achieved, the exterior of the bulb and the surrounding equipment must be cooled with fans. The bulbs and the cooling fans reduce system reliability, and the noise of the fan is unacceptable for many applications such as home theaters.

Accordingly, there is a need for improved light sources for image projection systems and for image projection systems that can employ such improved sources.

SUMMARY OF THE INVENTION

In accordance with the invention a light source for an image projection system comprises one or more LEDs packaged for high temperature operation. Advantageously, the LED die are disposed on a package comprising a ceramic

2

coated metal base including one or more underlying thermal connection pads, and underlying electrical connection pads, each LED die thermally coupled through the metal base to a thermal connection pad and electrically coupled to electrical connection pads. The LED can be mounted directly on the metal of the base or on a thin coating of electrical insulator on the metal. Arrays of LED die thus packaged are advantageously fabricated by the low temperature co-fired ceramic-on-metal technique (LTTC-M) and can be referred to as LTTC-M packaged arrays. The LEDs are advantageously mounted in an array of cavities having tapered sides to reflect light from the LEDs. The high temperature LED light sources can substitute for HID lamps in a variety of front and rear projection systems and displays. They are particularly useful for rear projection systems.

BRIEF DESCRIPTION OF THE DRAWINGS

The advantages, nature and various additional features of the invention will appear more fully upon consideration of the illustrative embodiments now to be described in detail in connection with the accompanying drawings. In the drawings:

FIG. 1 is a schematic diagram of an improved DMD image projector using a high temperature LED light source;

FIGS. 2A and 2B are schematic diagrams of an improved LED projector using high temperature LED light sources;

FIG. 3 is a schematic cross section of a first embodiment of an LED packaged for high temperature operation;

FIG. 4 illustrates how circuit components can be added to the overlying ceramic layer;

FIGS. 5A and 5B illustrate exemplary light dispersive cavities in the ceramic layer;

FIG. 6 is a schematic cross section of an alternative embodiment of an LED;

FIGS. 7, 8 and 9 show alternative embodiments of the packaged LED;

FIG. 10 depicts an array of LEDs in accordance with the embodiment of FIG. 3;

FIG. 11 illustrates, in schematic cross section an array that is particularly easy to fabricate;

FIGS. 12 and 13 are top views of advantageous arrays;

FIG. 14 shows the inventive LED array as a plug in card;

FIG. 15 shows the card of FIG. 14 mounted on an additional external heatsink;

FIGS. 16 and 17 are a top and side view of flip-chip die bonded to the traces of an LTCC-M package by solder or gold balls;

FIG. 18 shows conductive traces in an LTCC-M package;

FIG. 19 shows a single LED package having isolated base terminals and vias;

FIG. 20 shows the package of FIG. 19 adapted for a plurality of LED die; and

FIG. 21 shows a round punch tool for forming a tapered cavity.

It is to be understood that these drawings are for illustrating the concepts of the invention and are not to scale.

DETAILED DESCRIPTION

This description is divided into three parts. Part I describes exemplary projection systems using high temperatures LED light sources. Part II describes the structure and fabrication of high temperature LEDs. And Part III describes LTCC-M packaging of high temperature LEDs.

I. Exemplary Image Projection Systems Using High Temperature LED Light Sources

An image projection system comprises, in essence, a light source and an image defining element for receiving light from the source and modulating the distribution of light to transmit or reflect a desired image. The desired image may be specified electrically (as by a digital signal) or graphically (as by a photographic slide). The system may project onto the front of a viewing screen (front projector) or onto the rear of a viewing screen (rear projector). Two important types of image projectors are digital micromirror projectors (DMD projectors) and liquid crystal display projectors (LCD projectors). High temperature LED light sources provide unique advantages for each projector type.

A. DMD Projectors

DMD projectors use digital micromirror devices (DMDs) to define an image to be projected. A DMD is typically an optical semiconductor device comprising an array of microscopic mirrors. It may include a million or more micrometer scale mirrors, and each mirror can be electrically switched between a first position (ON) which reflects impinging light onto an image screen and a second position (OFF) which does not reflect onto the screen. The aggregate of the switched mirrors reflected onto the screen thus defines an image. By switching these individual micromirrors ON and OFF at high speed, the DMD projector system can translate a digital signal into a projected moving image.

FIG. 1 is a schematic diagram of an improved DMD projecting system 1 using a high temperature LED light source 2 in accordance with the invention. The system 1 comprises a light pipe 3, focusing optics 4 (schematically illustrated), a DMD 5 and a viewing screen (not shown) to receive the projected image. The light source 2 can comprise an arrayed plurality of red, green and blue high temperature LEDs (10R, 10G, 10B respectively). The LEDs 10 are switchable so that sub-arrays of red, green and blue diodes are separately switched on and off. The light pipe 3 assists in confining emitted light to paths directed toward the DMD 5.

In operation, a sequence of images interpreted by the eye as a moving colored image can be projected by successively switching on the sub-arrays of respectively different colored LEDs and synchronizing the switched colors with switched mirror configurations. The mirror configurations produce the appropriate red, blue and green image portions of each desired composite colored image. The composite images can be modulated in time to produce to a viewer the appearance of a moving colored image.

The LED array light source 2 should have high switching speed, high brightness, and small size. If the array produces light with a source size that is larger than the acceptance capacity of the DMD 5, light produced by the source will be lost. The individual LED die 10 are thus desirably closely spaced to form a nearly single light source. Such a concentration of LEDs 10 requires rapid removal of excess heat. Otherwise the heat will degrade the light output and reduce LED life and reliability. LED light sources packaged for high temperature operation, particularly LTCC-M packaged diodes, are thus highly advantageous for this projection system. Advantageously the LED die are disposed on a package comprising a ceramic-coated metal base including one or more underlying thermal connection pads and underlying electrical connection pads. Each LED die is thermally coupled through the metal base to the thermal connection pad and electrically coupled to the electrical connection pads. The LED die can be mounted directly on the metal of

the base or on a thin coating of electrical insulator on the metal. Advantageously, the LEDs are mounted in cavities having tapered sides to reflect light from the LEDs.

While the above-described exemplary embodiment uses a light source comprising red, green and blue high temperature LEDs, it should be understood that sets of other colored LEDs could be used so long as the colors can be combined into a substantially complete range of visible colors. Moreover, LEDs in other colors can be added to improve the color gamut, e.g. red, green and blue LEDs can be supplemented by cyan and amber LEDs.

It should also be recognized that the high temperature LEDs need not be "colored". The source can be comprised of one or more high temperature "white" LEDs and a rotating color wheel with filter sectors that are red transmitting, green transmitting and blue transmitting. The wheel can be disposed between the source and the DMD to project colored images. The color wheel can also be dispensed with, and a white or colored LED can be directed onto the DMD to project a "gray scale" or single color image. The white LEDs can be made with a UV LED impinging on a RGB (red-green-blue) phosphor or a RGB phosphor mixed with blue and yellow phosphors.

B. LCD Projectors

An LCD projector uses an LCD display to define an image. The LCD display typically comprises a liquid crystal solution suspended between glass plates. When an electric current between is passed through the solution, the current causes the crystals to align in a certain configuration. An array of electrodes can be provided for switchably applying current to specific small regions of the solution. As a result, light can pass through some crystal regions (ON) and not through others (OFF), thereby producing a projectable image.

FIGS. 2A and 2B are schematic diagrams of an improved LCD projector 6 using high temperature LED light sources 7R, 7G, 7B comprising red, green and blue LEDs, respectively, to illuminate, via light pipes 3, LCD displays 8R, 8G, and 8B that transmit red, green and blue. The displays are disposed along three sides of a trichroic prism 9 which combines the red, green and blue images into a composite color image that is projected onto viewing screen S. FIG. 2A depicts projection of an image onto the front of viewing screen S, and FIG. 2B depicts projection of an image onto the back of viewing screen S. The LCD displays can be modulated with electrical signals to generate the red, green and blue portions of a sequence of composites that appear to a viewer as a moving colored image. The high temperature LED light sources 7R, 7G, 7B provide for LCD projectors advantages similar to those provided for DMD projectors. The light sources are preferably LTTC-M packaged diodes.

It will be appreciated that the high temperature LED sources could alternatively be high temperature white LEDs with filters for transmitting red, green and blue respectively to the trichroic prism. Alternatively, for a gray scale display, the trichroic prism can be dispensed with and a white or colored high temperature LED light source can be used to illuminate the LCD.

The preferred light sources 2, 7 for projector applications, comprise arrayed pluralities of high temperature LEDs 10. The LED die are advantageously mounted directly on the surface of a metal core or separated from the core by a thin layer (\leq about 15 micrometers) of electrically insulating and thermally conducting material. The metal core is advantageously a thermally conducting metal (\geq about 170 W/mK) to keep the die cool during operation. The metal core also

has a low TCE close to the TCE of the LED die (e.g. about 6 ppm/° C.) to minimize stress on the LED die during operation and over a wide temperature range (−55 to 125° C.). The combination of low stress and high heat sinking ability makes possible a high concentration of LED die in a very small area. The structure and fabrication of such LED light sources is now described in detail.

II. The Structure and Fabrication of High Temperature LED's

FIG. 3A is a schematic cross section of an LED die **10** packaged for high temperature operation. LED die **10** is mounted overlying and thermally coupled to a metal base **11**. Advantageously the metal base **11** includes a patterned low thermal resistance, electrically insulating layer **12** to provide electrical insulation from the base **11** and a patterned conductive layer **13** to provide thermal coupling and electrical connection. The layers **12** and **13** can be patterned to provide insulation or electrical connection regions as desired. An LED **10** having an anode **10A** and a cathode **10C** can be mounted overlying the base **11** by solder bonding the electrodes **10A** and **10C** to conductive pad regions **13A** and **13C** of patterned conductive layer **13**.

Electrical connections may be made through the metal base **11** to underlying electrical connection pads **15A** and **15B** using electrically insulated vias **14** or the metal of the base **11**. Solderable electrical connection pads **15A** and **15B** may be deposited on the underside of metal base **11** to permit surface mounting of the base **11** on a printed circuit board (not shown). The remaining areas of the base **11** may be provided with one or more thermal connector pads **16** to carry heat from the LED package to the printed circuit board. Advantageously the base **11** makes contact with plated through holes (not shown) in a printed circuit board during solder assembly. Such through holes would transfer heat from the diode package into the PCB carrier (typically aluminum or copper).

Overlying the base **11**, one or more ceramic layers **17** can be added to the surface of the package. The ceramic layers on the base **11** form a cavity **18** around the LED **10**. The shape of the cavity walls, as will be discussed below, can affect the distribution of light from the LED **10**. The ceramic layer **17** can include circuitry for connecting multiple diodes in an array, electrostatic discharge protection circuitry, diode control and power supply connections and other surface mount components (not shown in FIG. 3).

A transparent cover **19** can be provided by bonding a transparent clear cover or lens over the cavity **18** (as by epoxy). The seal can be made hermetic by addition of a bonding pad and brazed seal ring (not shown).

In an advantageous embodiment, the metal base **11** is copper/molybdenum/copper (CMC), the low thermal resistance electrical insulating layer **12** (about 2 micrometers) can be an oxidized layer of the metal base, deposited glass or another deposited insulator such as nickel oxide (about 2 micrometers), and the conductive layer **13** can be gold, silver or other suitable conductor. The LED electrodes **10A**, **10C** can be solder bonded to the gold bonding pads **13A**, **13C** by AuSn solder. The underlying pads **15** and **16** for electrical connection and heat sinking are preferably PdAg and Ag, respectively.

As shown in FIG. 4, the ceramic layer **17** overlying base **11** can be composed of a plurality of ceramic layers **17A**, **17B**, **17C** and **17D**. Each ceramic layer can include circuit components for powering, controlling, protecting and interconnecting LEDs. While the circuitry will vary for different applications, FIG. 4 illustrates how to add surface mounted

active devices **20**, buried capacitors **21**, connectors **22**, interconnecting vias **23**, and buried resistors **24**. The metal base **11** with overlying ceramic layer **17** incorporating circuitry can be fabricated using the low temperature co-fired ceramic on metal technique (LTCC-M) described, for example, in U.S. Pat. No. 6,455,930 issued Sep. 24, 2002 and incorporated herein by reference.

Since a good amount of light is emitted from the edges of LED die, the shape of the ceramic cavity is an important factor in the total light efficiency. The ceramic cavity walls can be formed in a variety of ways including embossing, coining, stamping, forming by lamination, or routing the ceramic in the "green" or unfired state.

FIGS. 5A and 5B illustrate exemplary light dispersive cavities for the LED of FIG. 3. In FIG. 5A the cavity **18** is provided with walls **30** having straight taper. In FIG. 5B, the walls **31** have a parabolic taper. In general, each diode cavity **18** can be shaped to improve the light output and focus. White fired glass ceramic is reflective and disperses light to reduce the appearance of bright spots. The reflectivity of the cavity surface can be increased by polishing the surface or by applying a reflective coating such as silver, as by spraying, painting, sputtering or chemical vapor disposition. It is advantageous to smooth the side walls so that applied materials such as epoxy will shrink back and form a reflective gap.

FIG. 6 is a schematic cross section of an alternative embodiment of a single LED packaged for high temperature operation. In this embodiment a lens **40** overlying the LED **10** replaces the ceramic layer **17**, cavity **18** and lens cover **19**. The other features of the FIG. 6 device are substantially the same as described for the FIG. 3 device.

Other variations of the high temperature LED would include a LED die with a single electrode on the bottom of the package with the second electrode as a wire bondable pad on the top side. Or both electrodes could be on the top surface with wire bonding to each.

FIG. 7 is a schematic cross section of an alternative LED packaged for high temperature applications. The FIG. 7 device is similar to FIG. 3 device except that the metal base **51** is formed, as by coining, to include a concave light reflecting cavity **52** around the LED die **10**. FIG. 7 also illustrates that the LED die **10** can have one of its electrodes **53** on its top surface. The top electrode **53** can be connected, for example by a bonding wire **54** to a top bonding pad **55** on the ceramic **17** and through via **57** including insulated via section **56** to the bonding pad **15A** underlying the formed metal base **51**. The other LED electrode can be on the bottom surface connected to bonding pad **59** and further connected by way of the metal base and via **57** to the second underlying bonding pad **15B**. The formed metal base **51** can be provided with underlying ceramic supports **58A**, **58B** so that underlying bonding pads **15A**, **15B** are coplanar with thermal base connector **16**. This arrangement presents pads **15A**, **15B** and connector **16** in a single plane for surface mount connection onto a PC board.

The embodiment of FIG. 8 is similar to that of FIG. 7 except that the LED **10** is mounted on the ceramic layer **17** rather than on the formed metal base **51**. Here the ceramic layer **17**, conforming to the coined metal base, acts as a light reflector. The bottom electrode of the LED **10** can be connected to metal base **51** by way of a bonding pad **60** and conductive vias **61** through the ceramic to the base **51**. The vias **61** are constituted and dimensioned to conduct heat as well as electricity.

The FIG. 9 embodiment is similar to the FIG. 7 embodiment except that the cavity **18** in the ceramic layer **17** is

7

enlarged so that the shaped region of formed metal base **51** is more widely exposed for acting as a layer area reflector.

III. A. Light Sources Comprising Packaged Arrays of High Temperature LEDs

The LED structure of FIG. **3** may easily be replicated to form a light source **2** comprising an array of LEDs. FIG. **10** illustrates an exemplary array **80** of diodes **10**, with buried interconnection circuitry (not shown) added to the ceramic (**17** of FIG. **3**) connected to common electrodes **81A**, **81C**.

FIG. **11** is a schematic cross section of an array **90** of LTCC-M packaged LED diodes **10** that is particularly easy to fabricate. In essence array **90** comprises a plurality of diodes **10** disposed between a heat sink **91** and an apertured PC board **92**. The light emitting portion of each LED **10** is aligned with a corresponding window aperture **93** of PC board **92**. The PC board **92** advantageously contains the control and driver circuits (not shown) and electrical connections between the circuits and the LED's, e.g. connections **94**. The PC Board **92** can be conveniently secured to the heat sink (which can be a sheet of aluminum), as by screws **95**, to hold the diodes **10** in thermal contact with the heat sink. Advantageously thermal coupling between the diodes and the heat sink can be facilitated by thermal grease.

The array **90** is particularly easy to fabricate. After forming PC board **92** and providing a plurality of LTCC-M packaged diodes **10** as described herein, the diodes can be surface mounted on the PC board with the light emitting portions aligned with apertures, and LED contacts aligned with PC board contacts. After solder reflow connection, the PC board **92** can be secured to the heat sink **91** by screws **95**. The apertures and LEDs can be arranged across the surface of the board to achieve any desired configuration of a two-dimensional array of LEDs.

FIG. **12** is a top view illustrating a first advantageous configuration of LEDs **10** forming a closely packed hexagonal array. The PC board **92** includes common electrodes **81A** and **81C**.

FIG. **13** is a top view of a second advantageous configuration. The LEDs are distributed in a plurality of sets **111A**, **111B**, and **111C** in respective sectors around the circumference of a circle and in a set **111D** in the center of the circle, all to emulate a concentrated light source.

FIG. **14** shows an embodiment of the invention suitable for use as a plug in card. A plurality of cavities **122** includes a plurality LED die **123**, **124**, and **125**. LED die **123**, **124**, and **125** can be identical die (for increased luminosity), or they can be individual colors and lit in various patterns for single, or mixed color displays. They can also be lit in various combinations to give variable intensity or to show patterns. Card contact fingers **126**, **127**, **128**, and **129** show an exemplary embodiment to control the displayed color. Here, finger **129** is an electrical common (common cathode or common anode), and fingers **126**, **127**, and **128** are each connected to a single color die in each well to cause the card to light red, green, or blue respectively. In the example, each LED die is wired to the respective LED die of the same color in each well and to the respective control finger for that color. In another version of this embodiment, decoding/driver electronics can be embedded directly in the layers of the card and can control individual LED die or groups of die.

FIG. **15** shows card advantageously mounted on heat sink **132** for additional cooling. Also the card is shown plugged into edge connector **133** showing how contact is made with contact fingers **126**, **127**, **128**.

Semiconductor die can also be directly connected as flip-chips to any of the described LED assemblies. In this

8

embodiment, surfaces of the package can be bumped with a bondable material such as gold or solder. The bumps can be applied to correspond to the metal terminals of the semiconductor die. The die can then be attached to the package by applying heat and/or thermosonic agitation to create metallurgical connections between the bumped terminals on the package and the die terminals. This embodiment is shown in FIGS. **16** and **17**. FIG. **16** is a top view showing flip-chip die **143** in LTCC-M package **141**. FIG. **17** is a side view of the same assembly showing flip chip **143** connected to a wiring plane on surface **142** by bumps **144**. FIG. **18** shows a top view of a package before the die is installed. Wiring traces **161** can be seen residing on surface **142**.

In another embodiment of the invention, as shown in FIG. **19**, connections to the LED assembly can be made by isolated terminals **175** on base **174**. Openings in insulating layer **171** form wells for the LEDs as before. Insulating layer **171** can optionally include ground plane **172**. Metal vias **173** can facilitate electrical connections from isolated terminals **175** to the die via conductive traces (not shown). FIG. **20** shows a version of this embodiment designed to house a plurality of die **10**.

The invention may now be more clearly understood by consideration of the following specific example.

EXAMPLE

A part was built using a 13% copper, 74% molybdenum, 13% copper (CMC) metal laminate produced by H. C. Starck Corp. Thick film gold bonding pads are fired on the metal base to correspond to the location of each diode electrode. The pads are connected electrically and thermally to the CMC base. 4 layers of CMC-compatible ceramic tape are used to form the LED cavities, make the electrical connections, and form the array housing. The ceramic tape is composed of glasses and resins supplied by Ferro Corp. and others. The tape materials are ground, mixed, and cast into flat sheets. The sheets are then processed using common "green" tape processing including punching, printing, collating, and laminating.

The cavities are formed by routing (cutting away material with a rotary tool), pressing the shape using a rigid tool during lamination in the green state, or by punching the cavity in each ceramic layer (green-state punching) using a round punch tool **190** with punch shaft **191** and tapered shaft **192** (FIG. **21**). Round Punch **193** pushes out the ceramic tape chad, then the tapered shaft **192** presses a taper into the green tape. The surface is optionally coated with a silver or aluminum metal powder prior to each punch. During the punching operation the metal powder is transferred to the ceramic tape. When fired, the metal sinters into the ceramic. The surface of the taper can also be polished after firing using a rotary polishing tool. A polished surface can also result by using a ceramic powder with a finer grain size in the production of the ceramic tape. The finer grain size reduces the surface roughness of the finished part.

The CMC base is attached during lamination and joined to the tape layers during firing at ~900° C. Multiple arrays are processed on a single wafer, which is then singulated by dicing after firing. After the package is complete, individual diodes are connected to the gold pads in the bottom of each cavity by soldering using 80% Au/20% Sn solder, or using electrically conductive epoxy such as Ablebond 84LMI. The gold pads are connected to the metal base. Conductive vias connect an electrical terminal on the top ceramic layer to the metal base. The anode or cathode are commonly connected to the back side of the diode which is in-turn connected to

the gold bonding pad The opposite side of the diode is electrically connected to the array using a wire bond. The bond is connected from the diode to a bonding pad on one of the ceramic layers. Thick film, conductive traces are deposited onto the surface of the ceramic layer containing the bonding pads. The traces are connected to an electrical terminal on the top ceramic layer through electrically conductive vias. A variety of diode connections are possible including series, parallel, and combined series-parallel. Voltage dropping and current limiting resistors, inductors, and capacitors may be added as components buried in between the ceramic layers, or as discrete components mounted on the top surface of the package. Additional control, ESD protection, and voltage regulation semiconductors may be added in die or packaged form. Finally, an index matching epoxy, such as Hysol 1600, may be added to each diode cavity to improve the light output of each device, followed by a cover or lens that may be attached using clear Hysol 1600.

III. B. LTCC-M Packaging

Multilayer ceramic circuit boards are made from layers of green ceramic tapes. A green tape is made from particular glass compositions and optional ceramic powders, which are mixed with organic binders and a solvent, cast and cut to form the tape. Wiring patterns can be screen printed onto the tape layers to carry out various functions. Vias are then punched in the tape and are filled with a conductor ink to connect the wiring on one green tape to wiring on another green tape. The tapes are then aligned, laminated, and fired to remove the organic materials, to sinter the metal patterns and to crystallize the glasses. This is generally carried out at temperatures below about 1000° C., and preferably from about 750-950° C. The composition of the glasses determines the coefficient of thermal expansion, the dielectric constant and the compatibility of the multilayer ceramic circuit boards to various electronic components. Exemplary crystallizing glasses with inorganic fillers that sinter in the temperature range 700 to 1000° C. are Magnesium Alumino-Silicate, Calcium Boro-Silicate, Lead Boro-Silicate, and Calcium Alumino-Boricite.

More recently, metal support substrates (metal boards) have been used to support the green tapes. The metal boards lend strength to the glass layers. Moreover since the green tape layers can be mounted on both sides of a metal board and can be adhered to a metal board with suitable bonding glasses, the metal boards permit increased complexity and density of circuits and devices. In addition, passive and active components, such as resistors, inductors, and capacitors can be incorporated into the circuit boards for additional functionality. Where optical components, such as LEDs are installed, the walls of the ceramic layers can be shaped and/or coated to enhance the reflective optical properties of the package. Thus this system, known as low temperature cofired ceramic-metal support boards, or LTCC-M, has proven to be a means for high integration of various devices and circuitry in a single package. The system can be tailored to be compatible with devices including silicon-based devices, indium phosphide-based devices and gallium arsenide-based devices, for example, by proper choice of the metal for the support board and of the glasses in the green tapes.

The ceramic layers of the LTCC-M structure must be matched to the thermal coefficient of expansion of the metal support board. Glass ceramic compositions are known that match the thermal expansion properties of various metal or metal matrix composites. The LTCC-M structure and materials are described in U.S. Pat. No. 6,455,930, "Integrated heat sinking packages using low temperature co-fired ceramic metal circuit board technology", issued Sep. 24,

2002 to Palanisamy, et al and assigned to Lamina Ceramics. U.S. Pat. No. 6,455,930 is incorporated by reference herein. The LTCC-M structure is further described in U.S. Pat. Nos. 5,581,876, 5,725,808, 5,953,203, and 6,518,502, all of which are assigned to Lamina Ceramics and also incorporated by reference herein.

The metal support boards used for LTCC-M technology do have a high thermal conductivity, but some metal boards have a high thermal coefficient of expansion, and thus a bare die cannot always be directly mounted to such metal support boards. However, some metal support boards are known that can be used for such purposes, such as metal composites of copper and molybdenum (including from 10-25% by weight of copper) or copper and tungsten (including 10-25% by weight of copper), made using powder metallurgical techniques. Copper clad Kovar®, a metal alloy of iron, nickel, cobalt and manganese, a trademark of Carpenter Technology, is a very useful support board. AlSiC is another material that can be used for direct attachment, as can aluminum or copper graphite composites.

Another instance wherein good cooling is required is for thermal management of flip chip packaging. FIGS. 16 and 17, for example show the inventive LED system where the LTCC-M package houses LED die. Densely packed micro-circuitry, and devices such as decoder/drivers, amplifiers, oscillators and the like which generate large amounts of heat, can also use LTCC-M techniques advantageously. Metallization on the top layers of an integrated circuit bring input/output lines to the edge of the chip so as to be able to wire bond to the package or module that contains the chip. Thus the length of the wirebond wire becomes an issue; too long a wire leads to parasitics. The cost of very high integration chips may be determined by the arrangement of the bond pads, rather than by the area of silicon needed to create the circuitry. Flip chip packaging overcomes at least some of these problems by using solder bumps rather than wirebond pads to make connections. These solder bumps are smaller than wire bond pads and, when the chip is turned upside down, or flipped, solder reflow can be used to attach the chip to the package. Since the solder bumps are small, the chip can contain input/output connections within its interior if multilayer packaging is used. Thus the number of transistors in it, rather than the number and size of bond pads will determine the chip size.

However, increased density and integration of functions on a single chip leads to higher temperatures on the chip, which may prevent full utilization of optimal circuit density. The only heat sinks are the small solder bumps that connect the chip to the package. If this is insufficient, small active or passive heat sinks must be added on top of the flip chip. Such additional heat sinks increase assembly costs, increase the number of parts required, and increase the package costs. Particularly if the heat sinks have a small thermal mass, they have limited effectiveness as well.

In the simplest form of the present invention, LTCC-M technology is used to provide an integrated package for a semiconductor component and accompanying circuitry, wherein the conductive metal support board provides a heat sink for the component. A bare semiconductor die, for example, can be mounted directly onto a metal base of the LTCC-M system having high thermal conductivity to cool the semiconductor component. In such case, the electrical signals to operate the component must be connected to the component from the ceramic. In FIGS. 7, 8, and 9, wire bond 54 serves this purpose. Indirect attachment to the metal support board can also be used. In this package, all of the required components are mounted on a metal support board, incorporating embedded passive components such as conductors and resistors into the multilayer ceramic portion, to connect the various components, i.e., semiconductor com-

11

ponents, circuits, heat sink and the like, in an integrated package. The package can be hermetically sealed with a lid.

For a more complex structure having improved heat sinking, the integrated package of the invention combines a first and a second LTCC-M substrate. The first substrate can have mounted thereon a semiconductor device, and a multilayer ceramic circuit board with embedded circuitry for operating the component; the second substrate has a heat sink or conductive heat spreader mounted thereon. Thermoelectric (TEC) plates (Peltier devices) and temperature control circuitry are mounted between the first and second substrates to provide improved temperature control of semiconductor devices. A hermetic enclosure can be adhered to the metal support board.

The use of LTCC-M technology can also utilize the advantages of flip chip packaging together with integrated heat sinking. The packages of the invention can be made smaller, cheaper and more efficient than existing present-day packaging. The metal substrate serves as a heat spreader or heat sink. The flip chip can be mounted directly on the metal substrate, which is an integral part of the package, eliminating the need for additional heat sinking. A flexible circuit can be mounted over the bumps on the flip chip. The use of multilayer ceramic layers can also accomplish a fan-out and routing of traces to the periphery of the package, further improving heat sinking. High power integrated circuits and devices that have high thermal management needs can be used with this new LTCC-M technology.

It is understood that the above-described embodiments are illustrative of only a few of the many possible specific embodiments, which can represent applications of the invention. Numerous and varied other arrangements can be made by those skilled in the art without departing from the spirit and scope of the invention.

What is claimed is:

1. An image projection system comprising:
a LED light source;
an image defining element to receive light from the light source and to modulate the light to transmit or reflect an image;
wherein the LED light source comprises one or more LED die disposed on a ceramic-coated metal base coupled to a thermal connection pad and electrical connection pads, wherein each LED die is thermally coupled through the base to the thermal connection pad and electrically connected to the electrical connection pads.
2. The system of claim 1 wherein at least one LED die is mounted directly on the metal of the base.
3. The system of claim 1 wherein at least one LED die is separated from the base by a layer of electrical insulating and thermally conductive material having a thickness of 15 micrometers or less.
4. The system of claim 1 wherein the ceramic coating includes a cavity and at least one LED die is mounted in the cavity.
5. The system of claim 4 wherein the cavity has tapered sides to reflect light from the LED die.
6. The system of claim 1 wherein the metal base includes a concave region to reflect light and at least one LED die is mounted overlying the concave region.
7. The system of claim 1 wherein the electrical connection pads and the thermal connection pad underly the metal base and are coplanar.
8. The system of claim 1 wherein at least one LED die is mounted on the ceramic coating overlying the metal base and at least one LED die is thermally coupled to the metal base by a thermal via through the ceramic coating.

12

9. The system of claim 1 wherein at least one LED die is electrically connected to an electrical connection pad by an electrical path including a bonding wire.

10. The system of claim 1 wherein at least one LED die is electrically connected to an electrical connection pad by an electrical path including an insulated conducting via through the metal base.

11. The system of claim 1 wherein at least one LED die is connected to an electrical connection pad by an electrical path including the metal base.

12. The system of claim 1 wherein the light source comprises a plurality of LED die disposed in an array overlying a common metal base.

13. The system of claim 1 wherein the light source comprises at least one red-emitting LED, at least one green-emitting LED and at least one blue-emitting LED.

14. The system of claim 13 wherein the red, green and blue LEDs are separately switchable.

15. The system of claim 1 wherein the light source comprises a first array of red-emitting LEDs, a second array of green-emitting LEDs and a third array of blue-emitting LEDs.

16. The system of claim 15 wherein the red, green and blue LED arrays are separately switchable.

17. The system of claim 13 wherein the light source further comprises at least one cyan-emitting LED.

18. The system of claim 13 wherein the light source further comprises at least one yellow-emitting LED.

19. The system of claim 1 wherein the light source comprises at least one white-emitting LED.

20. The system of claim 1 wherein the light source comprises an array of white-emitting LEDs.

21. The system of claim 1 wherein the light source comprises an array of LEDs that emit light of the same color.

22. The system of claim 1 wherein the image defining element comprises a digital micromirror device.

23. The system of claim 1 wherein the image defining element comprises a digital micromirror device and the light source comprises separately switchable red, green and blue LEDs.

24. The system of claim 1 wherein the image defining element comprises a liquid crystal display.

25. The system of claim 1 wherein the image defining element comprises red, green and blue liquid crystal displays and the light source comprises red, green and blue LEDs for illuminating the corresponding colored liquid crystal displays.

26. The image projection system of claim 25 further comprising a trichroic crystal for receiving images from the illuminated red, green and blue liquid crystal displays and projecting therefrom a composite colored image.

27. The image projection system of claim 1 wherein the image projection system includes a viewing screen and the system is located to project an image onto the front of the screen.

28. The image projection system of claim 1 wherein the image projection system includes a viewing screen and the system is located to project an image onto the rear of the screen.