



US007274160B2

(12) **United States Patent**
Mueller et al.

(10) **Patent No.:** **US 7,274,160 B2**
(45) **Date of Patent:** **Sep. 25, 2007**

(54) **MULTICOLORED LIGHTING METHOD AND APPARATUS**

(75) Inventors: **George G. Mueller**, Boston, MA (US);
Ihor A. Lys, Milton, MA (US)

(73) Assignee: **Color Kinetics Incorporated**, Boston, TX (US)

(*) Notice: Subject to any disclaimer, the term of this patent is extended or adjusted under 35 U.S.C. 154(b) by 33 days.

(21) Appl. No.: **10/810,481**

(22) Filed: **Mar. 26, 2004**

(65) **Prior Publication Data**

US 2004/0178751 A1 Sep. 16, 2004

Related U.S. Application Data

(63) Continuation of application No. 09/971,367, filed on Oct. 4, 2001, now Pat. No. 6,788,011, which is a continuation of application No. 09/669,121, filed on Sep. 25, 2000, now Pat. No. 6,806,659, which is a continuation of application No. 09/425,770, filed on Oct. 22, 1999, now Pat. No. 6,150,774, which is a continuation of application No. 08/920,156, filed on Aug. 26, 1997, now Pat. No. 6,016,038.

(51) **Int. Cl.**
H05B 37/00 (2006.01)

(52) **U.S. Cl.** **315/312**; 315/294; 315/292;
315/316; 315/362; 362/231; 362/234; 362/236;
345/589

(58) **Field of Classification Search** 315/312,
315/313, 315-318, 292, 294, 297, 360, 362,
315/149, 158, 159; 345/589; 359/276-278,
359/289; 362/800, 240, 249, 234, 236, 231
See application file for complete search history.

(56) **References Cited**

U.S. PATENT DOCUMENTS

1,324,008 A 12/1919 D'Humy

1,603,055 A 10/1926 Williams
2,591,650 A 4/1952 Williams
2,642,553 A 6/1953 Williams
2,644,912 A 7/1953 Williams
2,651,743 A 9/1953 Williams
2,657,338 A 10/1953 Williams

(Continued)

FOREIGN PATENT DOCUMENTS

AU 6 267 9 12/1996
CA 2 134 848 12/1996

(Continued)

OTHER PUBLICATIONS

Brainard David H., "Colorimetry", Chapter 26, US, New York, McGraw-Hill, pp. 2601-2654, (1995).

(Continued)

Primary Examiner—Haissa Philogene
(74) *Attorney, Agent, or Firm*—Wolf, Greenfield & Sacks, P.C.

(57) **ABSTRACT**

Illumination methods and apparatus, in which a first number of first light sources are adapted to generate first radiation having a first spectrum, and a second number of second light sources are adapted to generate second radiation having a second spectrum different than the first spectrum. In one example, the first number of the first light sources and the second number of the second light sources are different. In another example, a first intensity of the first radiation and a second intensity of the second radiation are independently controlled so as to controllably vary at least an overall perceivable color of generated visible radiation. In yet another example, a first control signal controls all of the first light sources substantially identically, and a second control signal controls all of the second light sources substantially identically.

106 Claims, 7 Drawing Sheets

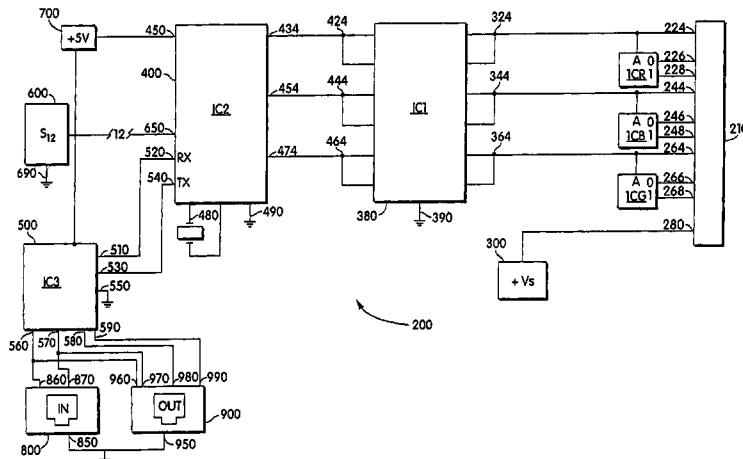

U.S. PATENT DOCUMENTS					
			4,635,052 A	1/1987	Aoike et al.
			4,641,227 A	2/1987	Kusuhara
			4,647,217 A	3/1987	Havel
			4,654,629 A	3/1987	Bezos et al.
			4,654,754 A	3/1987	Daszkowski
			4,656,398 A	4/1987	Michael et al.
			4,668,895 A	5/1987	Schneiter
			4,675,575 A	6/1987	Smith et al.
			4,677,533 A	6/1987	McDermott et al.
			4,682,079 A	7/1987	Sanders et al.
			4,686,425 A	8/1987	Havel
			4,687,340 A	8/1987	Havel
			4,688,154 A	8/1987	Nilssen
			4,688,869 A	8/1987	Kelly
			4,695,769 A	9/1987	Schweickardt
			4,701,669 A	10/1987	Head et al.
			4,705,406 A	11/1987	Havel
			4,707,141 A	11/1987	Havel
			4,727,289 A	2/1988	Uchida
			4,729,076 A	3/1988	Masami et al.
			4,740,882 A	4/1988	Miller
			4,753,148 A	6/1988	Johnson
			4,768,086 A	8/1988	Paist
			4,771,274 A	9/1988	Havel
			4,780,621 A	10/1988	Bartleucci et al.
			4,794,383 A	12/1988	Havel
			4,818,072 A	4/1989	Mohebban
			4,824,269 A	4/1989	Havel
			4,833,542 A	5/1989	Hara et al.
			4,837,565 A	6/1989	White
			4,843,627 A	6/1989	Stebbins
			4,845,481 A	7/1989	Havel
			4,845,745 A	7/1989	Havel
			4,857,801 A	8/1989	Farrell
			4,863,223 A	9/1989	Weissenbach et al.
			4,870,325 A	9/1989	Kazar
			4,874,320 A	10/1989	Freed et al.
			4,887,074 A	12/1989	Simon et al.
			4,922,154 A	5/1990	Cacoub
			4,929,866 A	5/1990	Murata et al.
			4,934,852 A	6/1990	Havel
			4,935,665 A	6/1990	Murata
			4,947,291 A	8/1990	McDermott
			4,957,291 A	9/1990	Miffitt et al.
			4,962,687 A	10/1990	Belliveau et al.
			4,963,798 A	10/1990	McDermott
			4,965,561 A	10/1990	Havel
			4,973,835 A	11/1990	Kurosu et al.
			4,974,119 A	11/1990	Martin
			4,979,081 A	12/1990	Leach et al.
			4,980,806 A	12/1990	Taylor et al.
			4,992,704 A	2/1991	Stinson
			5,003,227 A	3/1991	Nilssen
			5,008,595 A	4/1991	Kazar
			5,008,788 A	4/1991	Palinkas
			5,010,459 A	4/1991	Taylor et al.
			5,027,262 A	6/1991	Freed
			5,034,807 A	7/1991	Von Kohorn
			5,036,248 A	7/1991	McEwan et al.
			5,038,255 A	8/1991	Nishihashi et al.
			5,060,118 A	10/1991	Penrod
			5,072,216 A	12/1991	Grange
			5,078,039 A	1/1992	Tulk et al.
			5,083,063 A	1/1992	Brooks
			5,089,748 A	2/1992	Ihms
			5,122,733 A	6/1992	Havel
			5,126,634 A	6/1992	Johnson
			5,128,595 A	7/1992	Hara
			5,130,909 A	7/1992	Gross
			5,134,387 A	7/1992	Smith et al.
			5,136,483 A	8/1992	Schöniger et al.
2,673,923 A	3/1954	Williams			
2,686,866 A	8/1954	Williams			
2,725,461 A	11/1955	Amour			
2,909,097 A	10/1959	Alden et al.			
3,037,110 A	5/1962	Williams			
3,111,057 A	11/1963	Cramer			
3,163,077 A	12/1964	Shank			
3,201,576 A	8/1965	Scott			
3,205,755 A	9/1965	Sklar			
3,215,022 A	11/1965	Orgo			
3,240,099 A	3/1966	Irons			
3,241,419 A	3/1966	Gracey			
3,307,443 A	3/1967	Shallenberger			
3,318,185 A	5/1967	Kott			
3,540,343 A	11/1970	Rifkin			
3,550,497 A	12/1970	Marsh			
3,561,719 A	2/1971	Grindle			
3,586,936 A	6/1971	McLeroy			
3,601,621 A	8/1971	Ritchie			
3,643,088 A	2/1972	Osteen et al.			
3,644,785 A	2/1972	Jarmar			
3,696,263 A	10/1972	Wacher			
3,706,914 A	12/1972	Van Buren			
3,740,570 A	6/1973	Kaelin et al.			
3,746,918 A	7/1973	Drucker et al.			
3,760,174 A	9/1973	Boenning et al.			
3,787,752 A	1/1974	Delay			
3,818,216 A	6/1974	Larraburu			
3,832,503 A	8/1974	Crane			
3,845,468 A	10/1974	Smith			
3,858,086 A	12/1974	Anderson et al.			
3,875,456 A	4/1975	Kano et al.			
3,909,670 A	9/1975	Wakamatsu et al.			
3,924,120 A	12/1975	Cox, III			
3,942,065 A	3/1976	Russ			
3,958,885 A	5/1976	Stockinger et al.			
3,974,637 A	8/1976	Bergey et al.			
4,001,571 A	1/1977	Martin			
4,045,664 A	8/1977	Vrenken et al.			
4,054,814 A	10/1977	Fegley et al.			
4,070,568 A	1/1978	Gala			
4,074,318 A	2/1978	Kapes, Jr.			
4,074,319 A	2/1978	Goldschmidt et al.			
4,082,395 A	4/1978	Donato et al.			
4,095,139 A	6/1978	Symonds et al.			
4,096,349 A	6/1978	Donato			
4,151,547 A	4/1979	Rhoades et al.			
4,176,581 A	12/1979	Stuyvenberg			
4,241,295 A	12/1980	Williams, Jr.			
4,267,559 A	5/1981	Johnson et al.			
4,271,408 A	6/1981	Teshima et al.			
4,272,689 A	6/1981	Crosby et al.			
4,273,999 A	6/1981	Pierpoint			
4,298,869 A	11/1981	Okuno			
4,317,071 A	2/1982	Murad			
4,329,625 A	5/1982	Nishizawa et al.			
4,339,788 A	7/1982	White et al.			
4,342,906 A	8/1982	Hyatt			
4,342,947 A	8/1982	Bloyd			
4,367,464 A	1/1983	Kurahashi et al.			
4,388,567 A	6/1983	Yamazaki et al.			
4,388,589 A	6/1983	Moldrem, Jr.			
4,392,187 A	7/1983	Bornhorst			
4,420,711 A	12/1983	Takahashi et al.			
4,455,562 A	6/1984	Dolan et al.			
4,470,044 A	9/1984	Bell			
4,500,796 A	2/1985	Quin			
4,597,033 A	6/1986	Meggs et al.			
4,622,881 A	11/1986	Rand			
4,625,152 A	11/1986	Nakai			

US 7,274,160 B2

5,142,199 A	8/1992	Elwell	5,544,037 A	8/1996	Luger
5,143,442 A	9/1992	Ishikawa et al.	5,545,950 A	8/1996	Cho
5,154,641 A	10/1992	McLaughlin	5,559,681 A	9/1996	Duarte
5,161,879 A	11/1992	McDermott	5,561,346 A	10/1996	Byrne
5,164,715 A	11/1992	Kashiwabara et al.	5,575,459 A	11/1996	Anderson
5,165,778 A	11/1992	Matthias et al.	5,575,554 A	11/1996	Guritz
5,173,839 A	12/1992	Metz, Jr.	5,577,832 A	11/1996	Lodhie
5,184,114 A	2/1993	Brown	5,583,349 A	12/1996	Norman et al.
5,194,854 A	3/1993	Havel	5,583,350 A	12/1996	Norman et al.
5,209,560 A	5/1993	Taylor et al.	5,592,051 A	1/1997	Korkala
5,217,285 A	6/1993	Sopori	5,607,227 A	3/1997	Yasumoto et al.
5,225,765 A	7/1993	Callahan et al.	5,614,788 A	3/1997	Mullins et al.
5,226,723 A	7/1993	Chen	5,621,282 A	4/1997	Haskell
5,235,347 A	8/1993	Lee	5,621,603 A	4/1997	Adamec et al.
5,235,416 A	8/1993	Stanhope	5,633,629 A	5/1997	Hockstein
5,254,910 A	10/1993	Yang	5,634,711 A	6/1997	Kennedy et al.
5,256,948 A	10/1993	Boldin et al.	5,636,303 A	6/1997	Che et al.
5,262,658 A	11/1993	Jankowski	5,640,061 A	6/1997	Bornhorst et al.
5,268,828 A	12/1993	Miura	5,642,129 A	6/1997	Zavracky et al.
5,278,542 A	1/1994	Smith et al.	5,642,933 A	7/1997	Hitora
5,282,121 A	1/1994	Bornhorst et al.	5,653,529 A	8/1997	Spocharski
5,283,517 A	2/1994	Havel	5,655,830 A	* 8/1997	Ruskouski 362/240
5,287,352 A	2/1994	Jackson et al.	5,656,935 A	8/1997	Havel
5,294,865 A	3/1994	Haraden	5,668,537 A	9/1997	Chansky et al.
5,298,871 A	3/1994	Shimohara	5,671,996 A	9/1997	Bos et al.
5,301,090 A	4/1994	Hed	5,673,059 A	9/1997	Zavracky et al.
5,307,295 A	4/1994	Taylor et al.	5,684,309 A	11/1997	McIntosh et al.
5,329,431 A	7/1994	Taylor et al.	5,688,042 A	11/1997	Madadi et al.
5,350,977 A	9/1994	Hamamoto et al.	5,701,058 A	12/1997	Roth
5,352,957 A	10/1994	Werner	5,707,139 A	1/1998	Haitz
5,357,170 A	10/1994	Luchaco et al.	5,712,650 A	1/1998	Barlow
5,365,084 A	* 11/1994	Cochran et al. 250/559.02	5,721,471 A	2/1998	Begemann et al.
5,371,618 A	12/1994	Tai et al.	5,726,535 A	3/1998	Yan
5,374,876 A	12/1994	Horibata et al.	5,730,013 A	3/1998	Huang
5,375,043 A	12/1994	Tokunaga	5,734,590 A	3/1998	Tebbe
5,381,074 A	1/1995	Rudzewicz et al.	5,749,646 A	5/1998	Brittill
5,384,519 A	1/1995	Gotoh	5,751,118 A	5/1998	Mortimer
5,386,351 A	1/1995	Tabor	5,752,766 A	5/1998	Bailey et al.
5,388,357 A	2/1995	Malita	5,769,527 A	6/1998	Taylor et al.
5,400,228 A	3/1995	Kao	5,782,555 A	7/1998	Hochstein
5,402,702 A	4/1995	Hata	5,784,006 A	7/1998	Hockstein
5,404,282 A	4/1995	Klinke et al.	5,790,329 A	8/1998	Klaus et al.
5,406,176 A	4/1995	Sugden	5,803,579 A	9/1998	Turnbull et al.
5,410,328 A	4/1995	Yoksza et al.	5,806,965 A	9/1998	Deese
5,412,284 A	5/1995	Moore et al.	5,808,592 A	9/1998	Mizutani et al.
5,412,552 A	5/1995	Fernandes	5,808,689 A	9/1998	Small
5,418,697 A	5/1995	Chiou	5,812,105 A	9/1998	Van de Ven
5,420,482 A	5/1995	Phares	5,821,695 A	10/1998	Vilanilam et al.
5,421,059 A	6/1995	Leffers, Jr.	5,828,178 A	10/1998	York et al.
5,432,408 A	7/1995	Matsuda et al.	5,831,686 A	11/1998	Beretta
5,436,535 A	7/1995	Yang	5,836,676 A	11/1998	Ando et al.
5,436,853 A	7/1995	Shimohara	5,838,247 A	11/1998	Bladowski
5,450,301 A	9/1995	Waltz et al.	5,848,837 A	12/1998	Gustafson
5,461,188 A	10/1995	Drago et al.	5,850,126 A	12/1998	Kanbar
5,463,280 A	10/1995	Johnson	5,851,063 A	12/1998	Doughty et al.
5,465,144 A	11/1995	Parker et al.	5,852,658 A	12/1998	Knight et al.
5,471,052 A	11/1995	Ryczek	5,854,542 A	12/1998	Forbes
5,475,300 A	12/1995	Havel	RE36,030 E	1/1999	Nadeau
5,475,368 A	12/1995	Collins	5,857,767 A	1/1999	Hochstein
5,489,827 A	2/1996	Xia	5,859,508 A	1/1999	Ge et al.
5,491,402 A	2/1996	Small	5,893,631 A	4/1999	Padden
5,493,183 A	2/1996	Kimball	5,894,196 A	4/1999	McDermott
5,504,395 A	4/1996	Johnson et al.	5,895,986 A	4/1999	Walters et al.
5,515,136 A	5/1996	Nishio	5,896,010 A	4/1999	Mikolajczak et al.
5,519,496 A	5/1996	Borgert et al.	5,902,166 A	5/1999	Robb
5,521,708 A	5/1996	Beretta	5,907,742 A	5/1999	Johnson et al.
5,528,474 A	6/1996	Roney et al.	5,912,653 A	6/1999	Fitch
5,530,322 A	6/1996	Ference et al.	5,924,784 A	7/1999	Chliwnyj et al.
5,532,848 A	7/1996	Beretta	5,927,845 A	7/1999	Gustafson et al.
5,535,230 A	7/1996	Abe	5,938,321 A	8/1999	Bos et al.
5,541,817 A	7/1996	Hung	5,946,209 A	8/1999	Eckel et al.

5,949,581 A	9/1999	Kurtenbach et al.	6,331,915 B1	12/2001	Myers
5,952,680 A	9/1999	Strite	6,335,548 B1	1/2002	Roberts
5,959,316 A	9/1999	Lowery	6,340,868 B1	1/2002	Lys et al.
5,959,547 A	9/1999	Tubel et al.	6,357,889 B1	3/2002	Duggal et al.
5,961,201 A	10/1999	Gismondi	6,357,893 B1	3/2002	Belliveau
5,963,185 A	10/1999	Havel	6,361,198 B1	3/2002	Reed
5,974,553 A	10/1999	Gandar	6,369,525 B1	4/2002	Chang et al.
5,980,064 A	11/1999	Metroyanis	6,379,022 B1	4/2002	Amerson et al.
5,982,957 A	11/1999	DeCaro	6,386,720 B1	5/2002	Mochizuki
5,982,969 A	11/1999	Sugiyama et al.	6,411,046 B1	6/2002	Muthu
5,998,925 A	12/1999	Shimizu et al.	6,441,558 B1	8/2002	Muthu et al.
6,008,783 A	12/1999	Kitagawa et al.	6,441,943 B1	8/2002	Roberts
6,016,038 A	1/2000	Mueller et al.	6,445,139 B1	9/2002	Marshall et al.
6,018,237 A	1/2000	Havel	6,448,550 B1	9/2002	Nishimura
6,020,825 A	2/2000	Chansky et al.	6,459,919 B1	10/2002	Lys et al.
6,023,255 A	2/2000	Bell	6,469,322 B1	10/2002	Srivastava et al.
6,025,550 A	2/2000	Kato	6,474,837 B1	11/2002	Belliveau
6,028,694 A	2/2000	Schmidt	6,495,964 B1	12/2002	Muthu et al.
6,031,343 A	2/2000	Recknagel et al.	6,498,355 B1	12/2002	Harrah et al.
6,056,420 A	5/2000	Wilson et al.	6,504,301 B1	1/2003	Lowery
6,066,861 A	5/2000	Höhn et al.	6,507,159 B2	1/2003	Muthu
6,068,383 A	5/2000	Robertson et al.	6,508,564 B1	1/2003	Kuwabara et al.
6,069,597 A	5/2000	Hansen	6,510,995 B2	1/2003	Muthu et al.
6,072,280 A	6/2000	Allen	6,513,949 B1	2/2003	Marshall et al.
6,092,915 A	7/2000	Rensch	6,528,954 B1	3/2003	Lys et al.
6,095,661 A	8/2000	Lebens et al.	6,548,967 B1	4/2003	Dowling et al.
6,097,352 A	8/2000	Zavracky et al.	6,550,952 B1	4/2003	Hulse et al.
6,127,783 A	10/2000	Pashley et al.	6,551,282 B1	4/2003	Exline et al.
6,132,072 A	10/2000	Turnbull et al.	6,552,495 B1	4/2003	Chang
6,135,604 A	10/2000	Lin	6,568,834 B1	5/2003	Scianna
6,139,172 A	10/2000	Bos et al.	6,576,930 B2	6/2003	Reeh et al.
6,149,283 A	11/2000	Conway et al.	6,577,080 B2	6/2003	Lys et al.
6,150,771 A	11/2000	Perry	6,577,287 B2	6/2003	Havel
6,150,774 A	11/2000	Mueller et al.	6,592,238 B2	7/2003	Cleaver et al.
6,158,882 A	12/2000	Bischoff, Jr.	6,592,780 B2	7/2003	Höhn et al.
6,161,941 A	12/2000	Tait	6,596,977 B2	7/2003	Muthu et al.
6,166,496 A	12/2000	Lys et al.	6,600,175 B1	7/2003	Baretz et al.
6,175,201 B1	1/2001	Sid	6,608,453 B2	8/2003	Morgan et al.
6,175,342 B1	1/2001	Nicholson et al.	6,618,031 B1	9/2003	Bohn
6,181,126 B1	1/2001	Havel	6,624,597 B2	9/2003	Dowling et al.
6,183,086 B1	2/2001	Heubert	6,630,691 B1	10/2003	Mueller-Mach et al.
6,183,104 B1	2/2001	Ferrara	6,630,801 B2	10/2003	Schuurmans
6,184,628 B1	2/2001	Ruthenberg	6,636,003 B2	10/2003	Rahm et al.
6,188,181 B1	2/2001	Sinha et al.	6,676,284 B1	1/2004	Wynne Willson
6,190,018 B1	2/2001	Parsons et al.	6,692,136 B2	2/2004	Marshall et al.
6,196,471 B1	3/2001	Ruthenberg	6,717,376 B2	4/2004	Lys et al.
6,211,626 B1	4/2001	Lys et al.	6,720,745 B2	4/2004	Mueller et al.
6,212,213 B1	4/2001	Weber et al.	6,726,350 B1	4/2004	Herold
6,215,409 B1	4/2001	Blach	6,744,223 B2	6/2004	LaFlamme
6,220,722 B1	4/2001	Begemann	6,774,584 B2	8/2004	Morgan et al.
6,234,645 B1	5/2001	Borner et al.	6,787,999 B2	9/2004	Stimac et al.
6,234,648 B1	5/2001	Börner et al.	6,812,500 B2	11/2004	Reeh et al.
6,235,648 B1	5/2001	Mizuhara et al.	2001/0033488 A1	10/2001	Chliwnyj et al.
6,245,259 B1	6/2001	Höhn et al.	2002/0038157 A1	3/2002	Dowling et al.
6,250,774 B1	6/2001	Begemann et al.	2002/0044066 A1	4/2002	Dowling et al.
6,252,254 B1	6/2001	Soules et al.	2002/0047569 A1	4/2002	Dowling et al.
6,252,358 B1	6/2001	Xydis et al.	2002/0047624 A1	4/2002	Stam et al.
6,255,670 B1	7/2001	Srivastava et al.	2002/0048169 A1	4/2002	Dowling et al.
6,259,430 B1 *	7/2001	Riddle et al. 345/589	2002/0057061 A1	5/2002	Mueller et al.
6,273,338 B1	8/2001	White	2002/0060526 A1	5/2002	Timmermans et al.
6,273,589 B1	8/2001	Weber et al.	2002/0070688 A1	6/2002	Dowling et al.
6,277,301 B1	8/2001	Höhn et al.	2002/0074559 A1	6/2002	Dowling et al.
6,283,612 B1	9/2001	Hunter	2002/0078221 A1	6/2002	Blackwell et al.
6,292,901 B1	9/2001	Lys et al.	2002/0101197 A1	8/2002	Lys et al.
6,294,800 B1	9/2001	Duggal et al.	2002/0130627 A1	9/2002	Dowling et al.
6,299,329 B1	10/2001	Mui et al.	2002/0145394 A1	10/2002	Morgan et al.
6,299,338 B1	10/2001	Levinson et al.	2002/0145869 A1	10/2002	Dowling
6,310,590 B1	10/2001	Havel	2002/0152045 A1	10/2002	Dowling et al.
6,323,832 B1	11/2001	Nishizawa et al.	2002/0153851 A1	10/2002	Dowling et al.
6,329,764 B1	12/2001	van de Ven	2002/0158583 A1	10/2002	Lys et al.
6,330,111 B1	12/2001	Myers	2002/0163316 A1	11/2002	Dowling et al.

2002/0171365	A1	11/2002	Morgan et al.	EP	0495305	A2	7/1992
2002/0171377	A1	11/2002	Mueller et al.	EP	0567280	B1	10/1993
2002/0171378	A1	11/2002	Morgan et al.	EP	629508		6/1994
2002/0176259	A1	11/2002	Ducharme	EP	0639938	A1	2/1995
2002/0195975	A1	12/2002	Dowling et al.	EP	0689373	A2	12/1995
2003/0011538	A1	1/2003	Lys et al.	EP	0534710	B1	1/1996
2003/0028260	A1	2/2003	Blackwell	EP	0701390	A2	3/1996
2003/0057884	A1	3/2003	Dowling et al.	EP	0734082	A2	9/1996
2003/0057886	A1	3/2003	Lys et al.	EP	0752632	A2	1/1997
2003/0057887	A1	3/2003	Dowling et al.	EP	0752632	A3	8/1997
2003/0057890	A1	3/2003	Lys et al.	EP	0823812	A2	2/1998
2003/0076281	A1	4/2003	Morgan et al.	EP	0 838 866	A2	4/1998
2003/0100837	A1	5/2003	Lys et al.	EP	876085		4/1998
2003/0107887	A1	6/2003	Eberl	EP	0935234	A1	8/1999
2003/0133292	A1	7/2003	Mueller et al.	EP	0942631	A2	9/1999
2003/0137258	A1	7/2003	Piepgras et al.	EP	0971421	A2	1/2000
2003/0189412	A1	10/2003	Cunningham	EP	1020352	A2	7/2000
2003/0198061	A1	10/2003	Chambers et al.	EP	1 160 883	A2	5/2001
2003/0222587	A1	12/2003	Dowling et al.	EP	1113215	A2	7/2001
2004/0032226	A1	2/2004	Lys	EP	1162400	A2	12/2001
2004/0036006	A1	2/2004	Dowling	EP	2586844	A1 *	3/1987
2004/0052076	A1	3/2004	Mueller et al.	FR	2 640 791		6/1990
2004/0066652	A1	4/2004	Hong	FR	88 17359		12/1998
2004/0090787	A1	5/2004	Dowling et al.	FR	238327		8/1925
2004/0105261	A1	6/2004	Ducharme et al.	GB	238997		9/1925
2004/0130909	A1	7/2004	Mueller et al.	GB	271212		5/1927
2004/0218387	A1	11/2004	Gerlach	GB	296884		9/1928
2005/0122064	A1	6/2005	Chevalier et al.	GB	296885		9/1928
2005/0122292	A1	6/2005	Schmitz et al.	GB	325218		2/1930
2005/0122718	A1	6/2005	Kazar et al.	GB	368113		3/1932
2005/0128743	A1	6/2005	Chuey et al.	GB	376744		7/1932

FOREIGN PATENT DOCUMENTS

CA	2 178 432	12/1996		GB	411868		6/1934
CH	253968	12/1948		GB	412217		6/1934
DE	01950581	10/1969		GB	438884		11/1935
DE	02243245	9/1972		GB	441461		1/1936
DE	02315709	10/1974		GB	480126		2/1938
DE	0205307	12/1983		GB	481167		3/1938
DE	03526590 A1	7/1985		GB	640693		9/1950
DE	3526590 A1	1/1986		GB	646642		11/1950
DE	03438154 A1	4/1986		GB	661083		11/1951
DE	3837313	5/1989		GB	685209		12/1952
DE	3805998	9/1989		GB	686746		1/1953
DE	3925767 A1	4/1990		GB	712050		7/1954
DE	8902905	5/1990		GB	718535		11/1954
DE	3917101	11/1990		GB	942630		11/1963
DE	3916875	12/1990		GB	2045098 A		10/1980
DE	4041338	7/1992		GB	2131589 A		11/1982
DE	4130576 C1	3/1993		GB	2135536 A		8/1984
DE	9414688 U1	2/1995		GB	2176042 A		12/1986
DE	9414689	2/1995		GB	2210720 A		6/1989
DE	4419006 A1	12/1995		GB	2239306 A		6/1991
DE	19624087 A1	6/1996		JP	01031240 B2		2/1989
DE	29607270 U1	8/1996		JP	2247688		10/1990
DE	19638667 A1	9/1996		JP	2-269939		11/1990
DE	19525987	10/1996		JP	03045166		2/1991
DE	29620583 U1	2/1997		JP	04-015685		1/1992
DE	29620583 U1	3/1997		JP	4-39235		6/1992
DE	19651140 A1	6/1997		JP	1993073807 U		10/1993
DE	19602891 A1	7/1997		JP	06043830		2/1994
DE	19624087 A1	12/1997		JP	6334223		12/1994
DE	19829270 A1	7/1998		JP	07020711 B2		1/1995
DE	19829270 A1	1/1999		JP	7-39120		7/1995
DE	20007134 U1	4/2000		JP	7275200		10/1995
DE	20007134 U1	9/2000		JP	07335942 A		12/1995
EP	0 029 474 B1	3/1985		JP	8-106264		4/1996
EP	390479	3/1990		JP	08248901 A		9/1996
EP	507366	3/1992		JP	08293391 A		11/1996
EP	0482680 A1	4/1992		JP	08-007611		12/1996
EP	0490329 A1	6/1992		JP	09007774 A		1/1997
				JP	9139289		5/1997
				JP	9152840		6/1997

JP	09167861 A	6/1997
JP	9269746	10/1997
JP	10-071951	3/1998
JP	10242513 A	9/1998
JP	10302514	11/1998
JP	11039917 A	2/1999
JP	11087770 A	3/1999
JP	11087774 A	3/1999
JP	11133891 A	5/1999
JP	11202330 A	7/1999
JP	02000057488 A	2/2000
JP	2001-153690	6/2001
KR	1019910009812	11/1991
WO	WO 81/00637 A1	3/1981
WO	WO 81/01602 A1	6/1981
WO	WO 86/05409 A1	9/1986
WO	WO 89/05086	6/1989
WO	WO 94/18809	8/1994
WO	WO 95/13498	5/1995
WO	96/11499	4/1996
WO	WO 96/41098	12/1996
WO	WO 97/48138	12/1997
WO	WO 99/06759	2/1999
WO	WO 99/30537	6/1999
WO	WO 00/14705	3/2000
WO	WO 00/19141	4/2000
WO	WO 00/33390	6/2000
WO	WO 01/24229 A2	4/2001
WO	WO 01/73818 A1	10/2001
WO	WO 02/01921 A1	1/2002
WO	WO 02/061328 A1	8/2002
WO	WO 03/053108 A1	6/2003

OTHER PUBLICATIONS

Morrison David, "Brighter LEDs Signal Longer Life And Lower Power For Lighting Applications", www.planetec.com, Dec. 2000.

Robert K. John, "Binary Complementary Synthetic-White LED Illuminators", SAE Technical Paper Series, presented at the International Congress and Exposition; Detroit, Michigan, Mar. 1-4, 1999.

ARI International. "LED White Caps", www.ari-corp.com, (1999).

"LM117/LM317A/LM317 3-Terminal Adjustable Regulator", National Semiconductor Corporation, May 1997, pp. 1-20.

"DS96177 RS-485 / RS-422 Differential Bus Repeater", National Semiconductor Corporation, Feb. 1996, pp. 1-8.

"DS2003 / DA9667 / DS2004 High Current / Voltage Darlington Drivers", National Semiconductor Corporation, Dec. 1995, pp. 1-8.

"LM140A / LM140 / LM340A / LM7800C Series 3-Terminal Positive Regulators", National Semiconductor Corporation, Jan. 1995, pp. 1-14.

High End Systems, Inc., Trackspot User Manual, Aug. 1997, Excerpts (Cover, Title page, pp. ii through iii and 2-13 through 2-14).

Artistic License, AL4000 DMX512 Processors, Revision 3.4, Jun. 2000, Excerpts (Cover, pp. 7,92 through 102).

Artistic License, Miscellaneous Drawings (3 sheets) Jan. 12, 1995.

Artistic License, Miscellaneous Documents (2 sheets Feb. 1995 and Apr. 1996).

Newnes's Dictionary of Electronics, Fourth Edition, S.W. Amos, et al., Preface to First Edition, pp. 278-279.

"http://www.luminus.cx/projects/chaser", (Nov. 13, 2000), pp. 1-16.

Hewlett Packard Components, "Solid State Display and Optoelectronics Designer's Catalog," pp. 30-43, Jul. 1973.

INTEC Research, TRACKSPOT, <http://www.intec-research.com/trackspot.htm>, pp. 1-4, Apr. 24, 2003.

SHARP, Optoelectronics Data Book, pp. 1096-1097, 1994/1995.

About DMX-512 Lighting Protocol—Pangolin Laser Systems, pp. 1-4, Apr. 7, 2003.

Avitec Licht Design '89-90, pp. 1-4.

Dr. Ing, Ulrich Tietze, Dr. Ing, Christoph Schenk, pp. 566-569.

Case No. 6:02-cv-270-ORL-19JGG in the United States District Court, Middle District of Florida, Orlando Division, Plaintiff's Amended Verified Complaint.

Case No. 6:02-cv-270-ORL-19JGG in the United States District Court, Middle District of Florida, Orlando Division, Defendant's Answer and Counterclaims.

Case No. 6:02-cv-270-ORL-19JGG in the United States District Court, Middle District of Florida, Orlando Division, Plaintiff's Answer to Counterclaims.

Case No. 6:02-cv-270-ORL-19JGG in the United States District Court, Middle District of Florida, Orlando Division, Plaintiff's Answers to Defendant's First Set of Interrogatories w/Exhibit 1.

Case No. 02 CV 11137MEL in the United States District Court, District of Massachusetts, Plaintiff's Complaint and Jury Demand.

Case No. 02 CV 11137MEL in the United States District Court, District of Massachusetts, Defendant's Answer and Affirmative Defenses.

Furry, Kevin and Somerville, Chuck, Affidavit, LED effects, Feb. 22, 2002, pp. 24-29.

Putman, Peter H., "The Allure of LED," www.sromagazine.biz, Jun./Jul. 2002, pp. 47-52.

Bremer, Darlene, "LED Advancements Increase Potential," www.ecmag.com, Apr. 2002, p. 115.

Longo, Linda, "LEDS Lead the Way," Home Lighting & Accessories, Jun. 2002, pp. 226-234.

iLight Technologies, "Explore the iLight Possibilities", <http://www.ilight-tech.com>, Sep. 7, 2004, 1 page.

iLight Technologies, "Curved or straight in white or color", <http://www.ilight-tech.com/products.htm>, Sep. 7, 2004, 1 pages.

iLight Technologies, "Curved or straight in white or color"/products_white.htm, Sep. 7, 2004, 1 page.

iLight Technologies, "Curved or straight in white or color"/products_color.htm, Sep. 7, 2004, 1 page.

iLight Technologies, "Curved or straight in white or color"/products_signs.htm, Sep. 7, 2004, 1 page.

Color Kinetics v. Super Vision International, Inc., "Preliminary Expert Witness Report of Dr. David I. Kennedy Prepared and Submitted on Behalf of Super Vision International, Inc.," United States District Court of Massachusetts Case No. 02 CV 11137 MEL.

G. MacGregor et al., "Solid-State Displays for CRT Replacement in Data Annotation Systems," Optotek Limited, Proceedings, IEEE-SID Conference on Display, Devices and Systems, 1974, Washington, DC, pp. 59-65.

P.G. Wareberg and D.I. Kennedy, "Flat-Panel Video Resolution LED Display System," Optotek Limited, IEEE, 1982, pp. 746-751.

R.J. Spiger, "LED Multifunction Keyboard Engineering Study," Jun. 1983.

- D. Effer et al., "Fabrication and Properties of Gallium Phosphide Variable Colour Displays," Jul. 1973.
- David I. Kennedy, "Fabrication and Properties of Gallium Phosphide Variable Colour Displays," *Microelectronics*, vol. 5, No. 3, 1974, pp. 21–29.
- Optotek Limited, Technical Manual for Multicolor Interactive Switch Module AN-601 and Input Simulator AN-600, Sep. 1986.
- Des Keppel, "Tech Tips, Pulse Adding Circuit," ETI Nov. 1986.
- Neil Muir, "Dual Colour LED Driver," ETI Nov. 1986.
- Multicolour Pendant, Maplin Magazine, Dec. 1981.
- "Solid-State Dark Room Lighting," *Elektor*, Oct. 1983.
- Open Letter to the USPTO, Oct. 14, 2004, <http://www.artisticlicense.com/app.notes/appnote027.pdf>.
- <http://www.artisticlicense.com/appnotes/appnote015.pdf>, pp. 1–17.
- Adrian b. Ettlinger and Salvatore J. Bonsignore, "A CBS Computerized Lighting Control System," *Journal of the SMPTE*, Apr. 1972, pp. 277–281, vol. 81.
- D.C. Irving, "Techniques of Stage and Studio Lighting Control," *Proceedings of the IREE*, Nov. 1975, pp. 359–364.
- United States District Court District of Massachusetts, Case No. 02 CV 11137 MEL, *Color Kinetics Incorporated v. Super Vision International, Inc.*, "Expert Witness Rebuttal Report of Dr. David I. Kennedy Prepared and Submitted on Behalf of Super Vision International, Inc."
- United States District Court District of Massachusetts, Case No. 02 CV 11137 MEL, *Color Kinetics Incorporated v. Super Vision International, Inc.*, "Super Vision International, Inc.'s Motion for Summary Judgment Against Color Kinetics, Inc."
- United States District Court District of Massachusetts, Case No. 02 CV 11137 MEL, *Color Kinetics Incorporated v. Super Vision International, Inc.*, "Color Kinetics' Memorandum in Support of its Motion for Summary Judgment on the Issue of Infringement".
- United States District Court District of Massachusetts, Case No. 02 CV 11137 MEL, *Color Kinetics Incorporated v. Super Vision International, Inc.*, "Color Kinetics' Memorandum in Support of its Motion for Summary Judgment on the Issue of Invalidity".
- United States District Court District of Massachusetts, Case No. 02 CV 11137 MEL, *Color Kinetics Incorporated v. Super Vision International, Inc.*, "Color Kinetics' Memorandum in Support of its Motion for Summary Judgment on Super Vision's 'Badmouthing' Claims".
- United States District Court District of Massachusetts, Case No. 02 CV 11137 MEL, *Color Kinetics Incorporated v. Super Vision International, Inc.*, "Color Kinetics' Memorandum in Support of its Motion for Summary Judgment on the Issue of Inequitable Conduct".
- United States District Court District of Massachusetts, Case No. 02 CV 11137 MEL, *Color Kinetics Incorporated v. Super Vision International, Inc.*, "Color Kinetics' Opening Memorandum Concerning Claim Construction".
- Schlig, Eugene S., "Electrothermal Considerations in Display Applications of Light-Emitting Diodes," *IEEE Transactions on Electron Devices*, vol. ED-19, No. 7, Jul. 1982, pp. 847–851.
- Asai, S. et al., "Heat Conductive Wire Matrix Board for Light Emitting Diode (LED) Dot Matrix Display," *Circuit World*, vol. 21, No. 4, 1995, pp. 27–31.
- "Cree Research, Inc. Announces Fiscal 1994 Results," *PR Newswire*, Jul. 28, 1994, pp. 1–2.
- "Cree Research, Inc. Announces Acquisition of Full-Color LED Display Company," *PR Newswire*, Aug. 9, 1994, pp. 1–2.
- Mishiko, Yashuhiro, et al., "Large-Scale Color LED Display System," *National Technical Report*, vol. 33, No. 1, Feb. 1987, pp. 94–101.
- Miyoshi, Morimasa et al., "Large-Scale Color LED Stock-Information Display Board," *National Technical Report*, vol. 33, No. 1, Feb. 1987, pp. 102–107.
- Motozono, Takefumi et al., "LED Display Devices," *National Technical Report*, vol. 28, No. 1, Feb. 1982, pp. 74–82.
- Tsujikado, Kazumi et al., "Large-Scale LED Display System," *National Technical Report*, vol. 42, No. 3, Jun. 1996, pp. 18–25.
- Shibata, Kazuhisa, "Improvements in Multicolored LEDs May be Practical Display Alternative," *JEE*, Aug. 1985, pp. 60–62.
- Murata, Kazuhisa, "Developers Continue to Refine Blue LED Technologies for Display Use," *Display Devices*, 1992, serial No. 6, pp. 46–50.
- Koga, Kazuyuki et al., "RGB Multi-Color LED DOT-Matrix Units and Their Application to Large-Size Flat Displays," *Optoelectronics-Devices and Technologies*, vol. 7, No. 2, pp. 221–229, Dec. 1992.
- Murata, Kazuhisa, "SiC Brightens Blues for Full-Color LED Display Units," *JEE*, Nov. 1993, pp. 59–65.
- Lerner, Eric. J., "Laser Diodes and LEDs Light Optoelectronic Devices," *Laser Focus World*, Feb. 1997, pp. 109–117.
- Martin, David, et al., "Material Advances Light Full-Color LED Displays," *Laser Focus World*, Mar. 1997, pp. 119–124.
- LEDtronics, Inc., LEDtronics Press Releases, "Conversion to LED System Provides Safe, Cost-Effective Lighting for Safelight Manufacturing," and "Ultra-Bright LED Replacements Offered for Industrial Control, Motor Control, Pilot Lights," Jun. 30, 1997.
- Color Kinetics Incorporated v. Super Vision International, Inc.*, "Declaration of Wayne Howell in Opposition to Color Kinetics's Motions for Summary Judgment Against Super Vision International, Inc.," United States District Court, District of Massachusetts, Case No. 02 CV 11137 MEL.
- Color Kinetics Incorporated v. Super Vision International, Inc.*, "Declaration of Jerry Laidman in Opposition of Color Kinetics, Inc.'s Motion for Summary Judgment Against Super Vision International, Inc.," United States District Court, District of Massachusetts, Case No. 02 CV 11137 MEL.
- Color Kinetics Incorporated v. Super Vision International, Inc.*, "Affidavit of Alfred D. Ducharme," United States District Court, District of Massachusetts, Case No. 02 CV 11137 MEL.
- Color Kinetics Incorporated v. Super Vision International, Inc.*, "Declaration of Clive Mitchell in Opposition of Color Kinetics Inc.'s Motion for Summary Judgment Against Super Vision International, Inc.," United States District Court, District of Massachusetts, Case No. 02 CV 11137 MEL.

- Color Kinetics Incorporated v. Super Vision International, Inc.*, “Declaration of Bruce Hagopian in Support of Super Vision International, Inc.’s Motion for Summary Judgment Against Color Kinetics, Inc.,” United States District Court, District of Massachusetts, Case No. 02 CV 11137 MEL.
- Color Kinetics Incorporated v. Super Vision International, Inc.*, “Declaration of William Little in Opposition to Color Kinetics’s Motions for Summary Judgment Against Super Vision International, Inc.,” United States District Court, District of Massachusetts, Case No. 02 CV 11137 MEL.
- Color Kinetics Incorporated v. Super Vision International, Inc.*, “Super Vision International, Inc.’s Notice of Filing Declaration of Brent W. Brown,” United States District Court, District of Massachusetts, Case No. 02 CV 11137 MEL.
- Color Kinetics Incorporated v. Super Vision International, Inc.*, “Super Vision International, Inc.’s Notice of Filing Amended Declaration of George G. Izenour,” United States District Court, District of Massachusetts, Case No. 02 CV 11137 MEL.
- Color Kinetics Incorporated v. Super Vision International, Inc.*, “Super Vision International, Inc.’s Notice of Filing Declaration of Paul A. Miller,” United States District Court, District of Massachusetts, Case No. 02 CV 11137 MEL.
- Color Kinetics Incorporated v. Super Vision International, Inc.*, “Declaration of Brett Kingstone in Opposition to Color Kinetic’s Motion for Summary Judgment Against Super Vision International, Inc.,” United States District Court, District of Massachusetts, Case No. 02 CV 11137 MEL.
- Proctor, P., “Bright Lights, Big Reliability,” *Aviation Week and Space Technology*, Sep. 5, 1994, vol. 141, No. 10. p. 29, Abstract Only.
- Pollack, A., “The Little Light That Could,” *The New York Times*, Apr. 29, 1996, Business/Financial Desk, Section D, p. 1, col. 2, Abstract Only.
- Chinnock, C., “Blue Laser, Bright Future,” *Byte*, Aug. 1995, vol. 20, Abstract Only.
- Electronics*, vol. 67, No. 20, p. A4, Abstract Only.
- Color Kinetics v. Super Vision International, Inc.*, “Super Vision International, Inc.’s Notice of Filing Declaration of Steve Faber,” United States District Court, District of Massachusetts, Case No. 02 CV 11137 MEL.
- Color Kinetics v. Super Vision International, Inc.*, “Super Vision International, Inc.’s Notice of Filing Declaration of Russell Martin,” United States District Court, District of Massachusetts, Case No. 02 CV 11137 MEL.
- Color Kinetics v. Super Vision International, Inc.*, “Super Vision International, Inc.’s Notice of Filing Declaration of Tam Bailey,” United States District Court, District of Massachusetts, Case No. 02 CV 11137 MEL.
- Color Kinetics v. Super Vision International, Inc.*, “Super Vision International, Inc.’s Notice of Filing Declaration of Peter Micha,” United States District Court, District of Massachusetts, Case No. 02 CV 11137 MEL.
- Color Kinetics v. Super Vision International, Inc.*, “Super Vision International, Inc.’s Notice of Filing Declaration of Brett Kingstone Part I,” United States District Court, District of Massachusetts, Case No. 02 CV 11137 MEL.
- Color Kinetics v. Super Vision International, Inc.*, “Super Vision International, Inc.’s Notice of Filing Declaration of Brett Kingstone Part II,” United States District Court, District of Massachusetts, Case No. 02 CV 11137 MEL.
- Color Kinetics v. Super Vision International, Inc.*, “Super Vision International, Inc.’s Notice of Filing Declaration of Brett Kingstone Part III,” United States District Court, District of Massachusetts, Case No. 02 CV 11137 MEL.
- Color Kinetics v. Super Vision International, Inc.*, “Super Vision International, Inc.’s Notice of Filing Declaration of Brett Kingstone Part IV,” United States District Court, District of Massachusetts, Case No. 02 CV 11137 MEL.
- Color Kinetics v. Super Vision International, Inc.*, “Super Vision International, Inc.’s Notice of Filing Declaration of Brett Kingstone Part V,” United States District Court, District of Massachusetts, Case No. 02 CV 11137 MEL.
- Color Kinetics v. Super Vision International, Inc.*, “Super Vision International, Inc.’s Notice of Filing Declaration of Brett Kingstone Part VII,” United States District Court, District of Massachusetts, Case No. 02 CV 11137 MEL.
- Color Kinetics v. Super Vision International, Inc.*, “Super Vision International, Inc.’s Notice of Filing Declaration of Brett Kingstone Part VIII,” United States District Court, District of Massachusetts, Case No. 02 CV 11137 MEL.
- Color Kinetics v. Super Vision International, Inc.*, “Super Vision International, Inc.’s Notice of Filing Declaration of Brett Kingstone Part IX,” United States District Court, District of Massachusetts, Case No. 02 CV 11137 MEL.
- Color Kinetics v. Super Vision International, Inc.*, “Super Vision International, Inc.’s Notice of Filing Declaration of Brett Kingstone Part X,” United States District Court, District of Massachusetts, Case No. 02 CV 11137 MEL.
- Color Kinetics v. Super Vision International, Inc.*, “Super Vision International, Inc.’s Notice of Filing Declaration of Brett Kingstone Part XI,” United States District Court, District of Massachusetts, Case No. 02 CV 11137 MEL.
- Munch, W., “Fortschritte in der Bewertung der Farbwiedergabe durch Lichtquellen.” Tagungsbericht über das IV, Internationale Kolloquium an der Hochschule für Elektronik Ilmenau, Oct. 1959.
- Bass, M., “Handbook of Optics,” McGraw Hill, USA, 1995, p. 26.33.
- Girardet, V. W., “Handbuch für Beleuchtung,” Essen, Germany 1975.
- Ganslandt et al., “Handbuch der Lichtplanung,” Vieweg + Sohn, Wiesbaden, 1992.
- Nakamura, S., “The Blue Laser Diode,” Seiten 7–10, pp. 216–221, Springer Verlag, Berlin, Germany, 1997.
- Opposition Brief, May 8, 2006, by Osram GmbH, opposing European Patent No. 1234140, pp. 1–21.
- Opposition Brief, May 4, 2006, by Tridonic Atco GmbH and Co. KG, opposing European Patent No. 1234140, pp. 1–21.
- Opposition Brief, May 10, 2006, by ERCO Leuchten GmbH, opposing European Patent No. 1234140, pp. 1–20.
- Opposition Brief, May 10, 2006, by Koninklijke Philips Electronics N.V., opposing European Patent No. 1234140, pp. 1–24.
- Bachiochi, J., “LEDs Finally Fill the Rainbow,” *Circuit Cellar INK*, Apr. 1996, pp. 84–89, Issue #69.

* cited by examiner

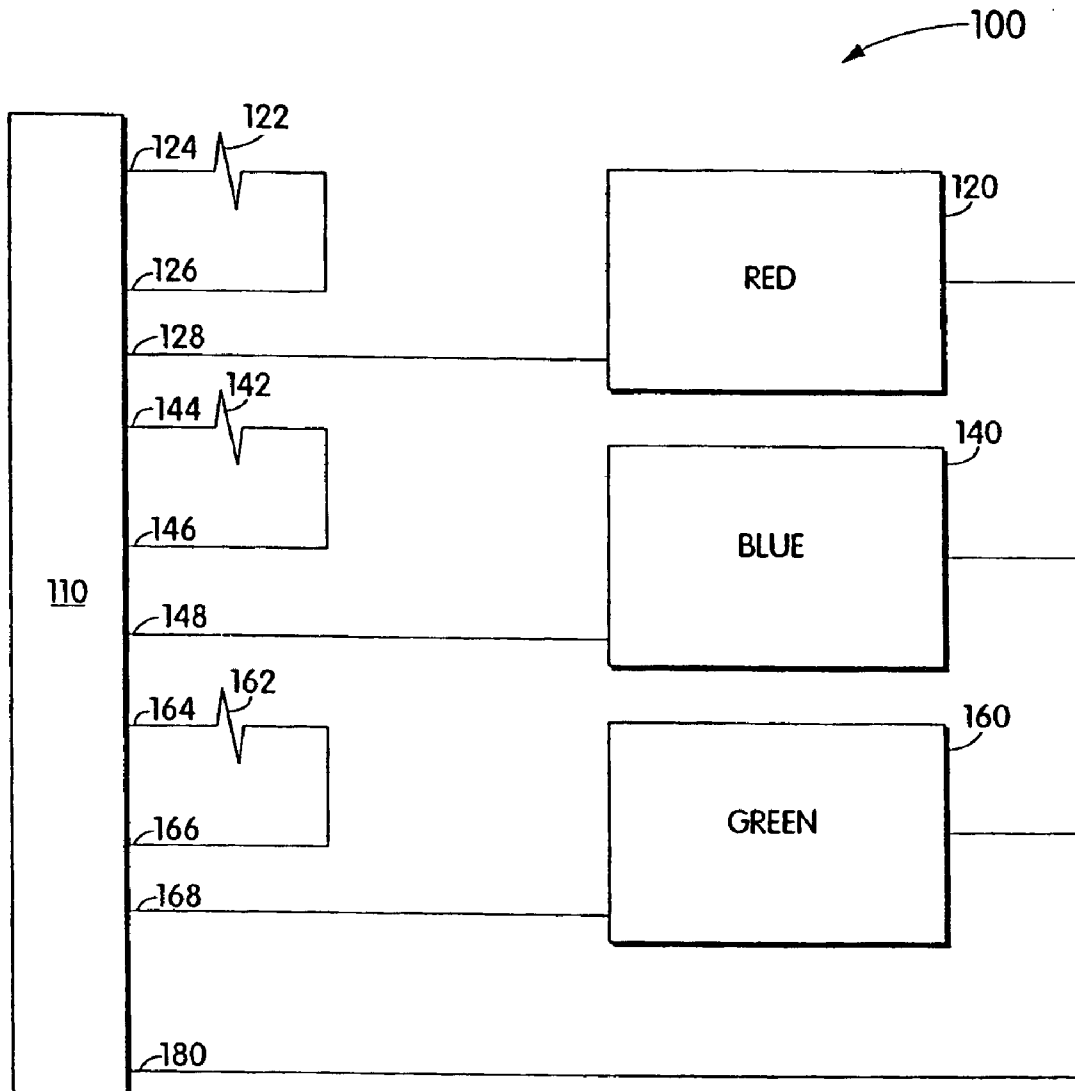

Fig. 1

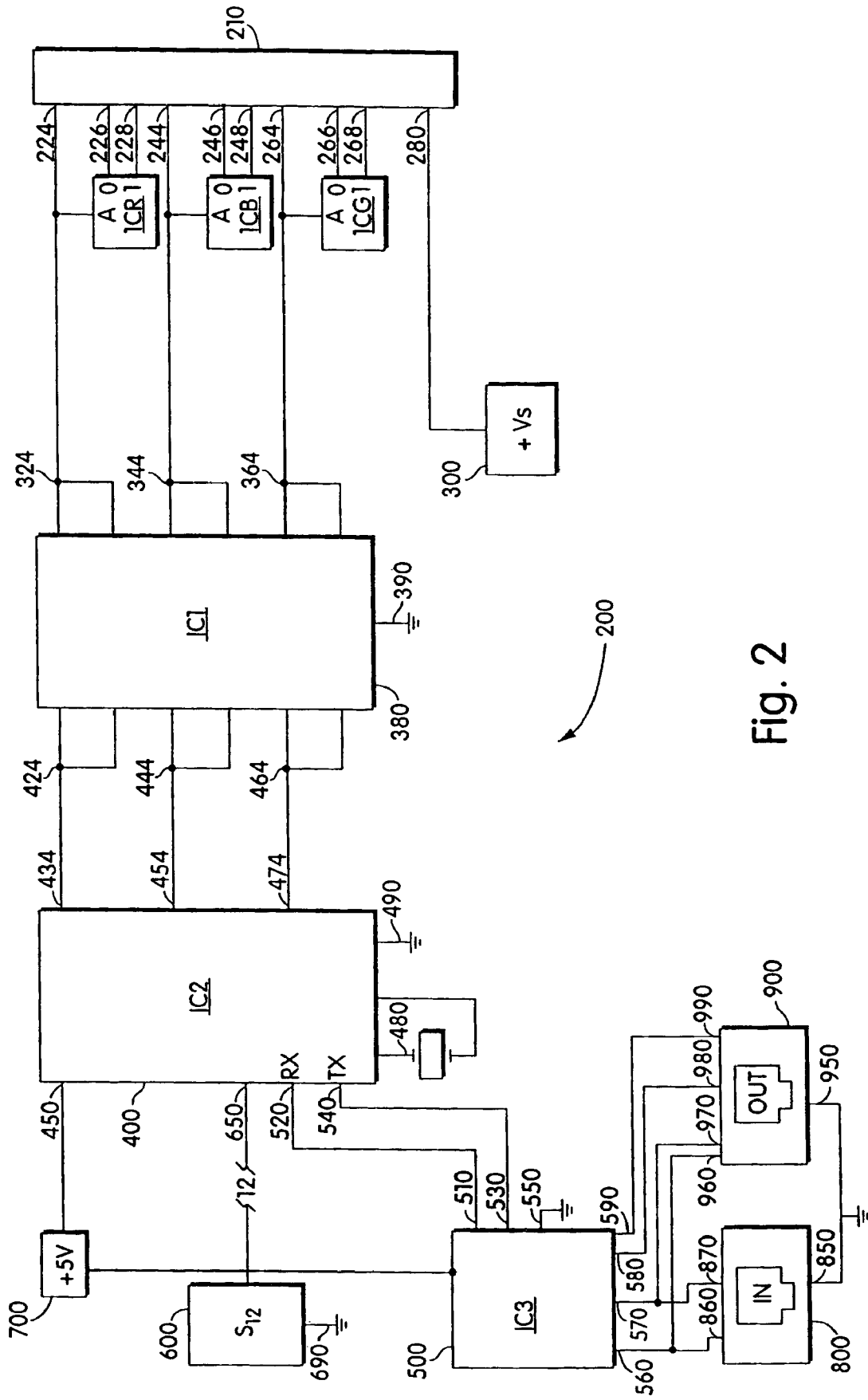

Fig. 2

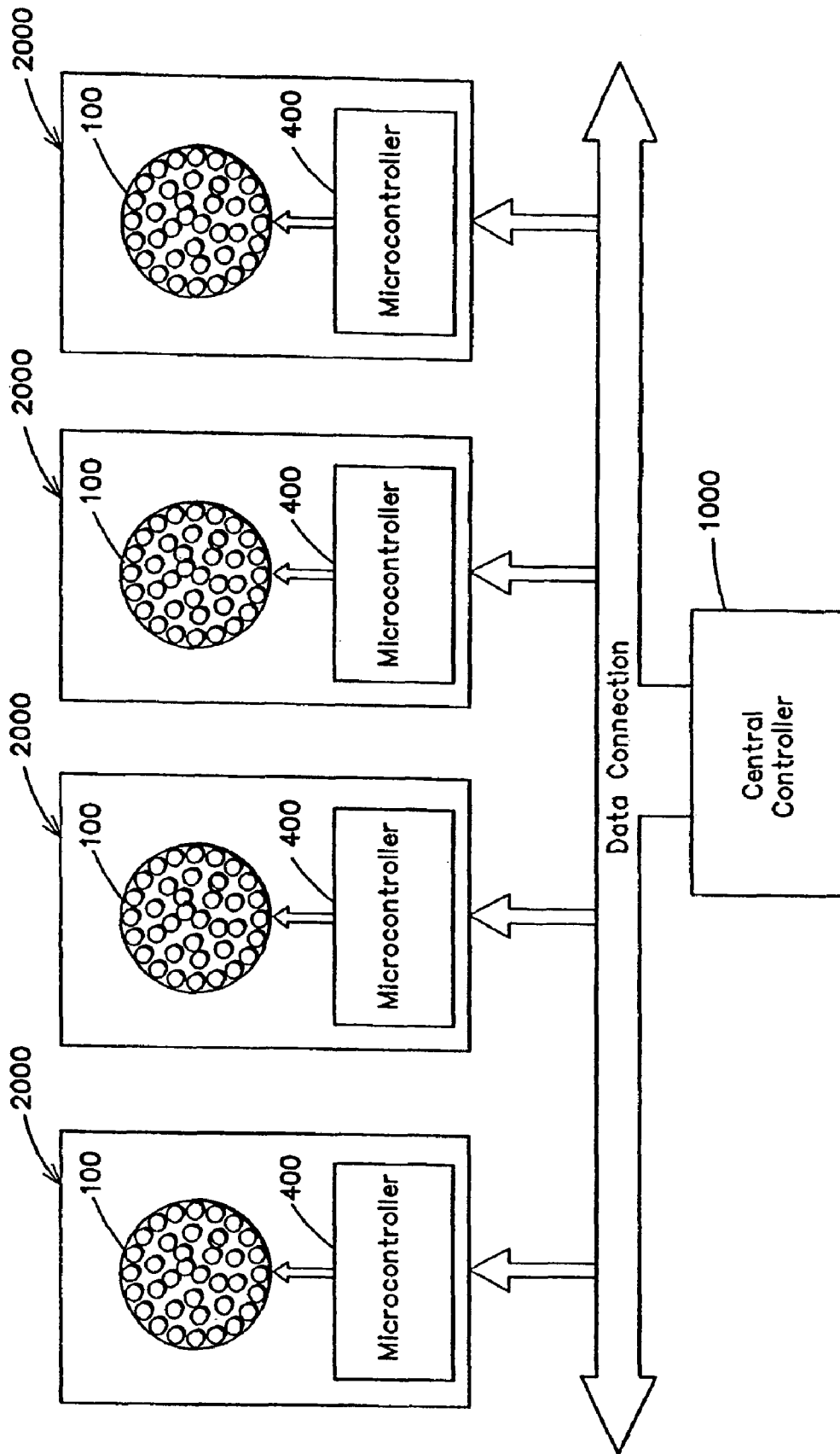

Fig. 2A

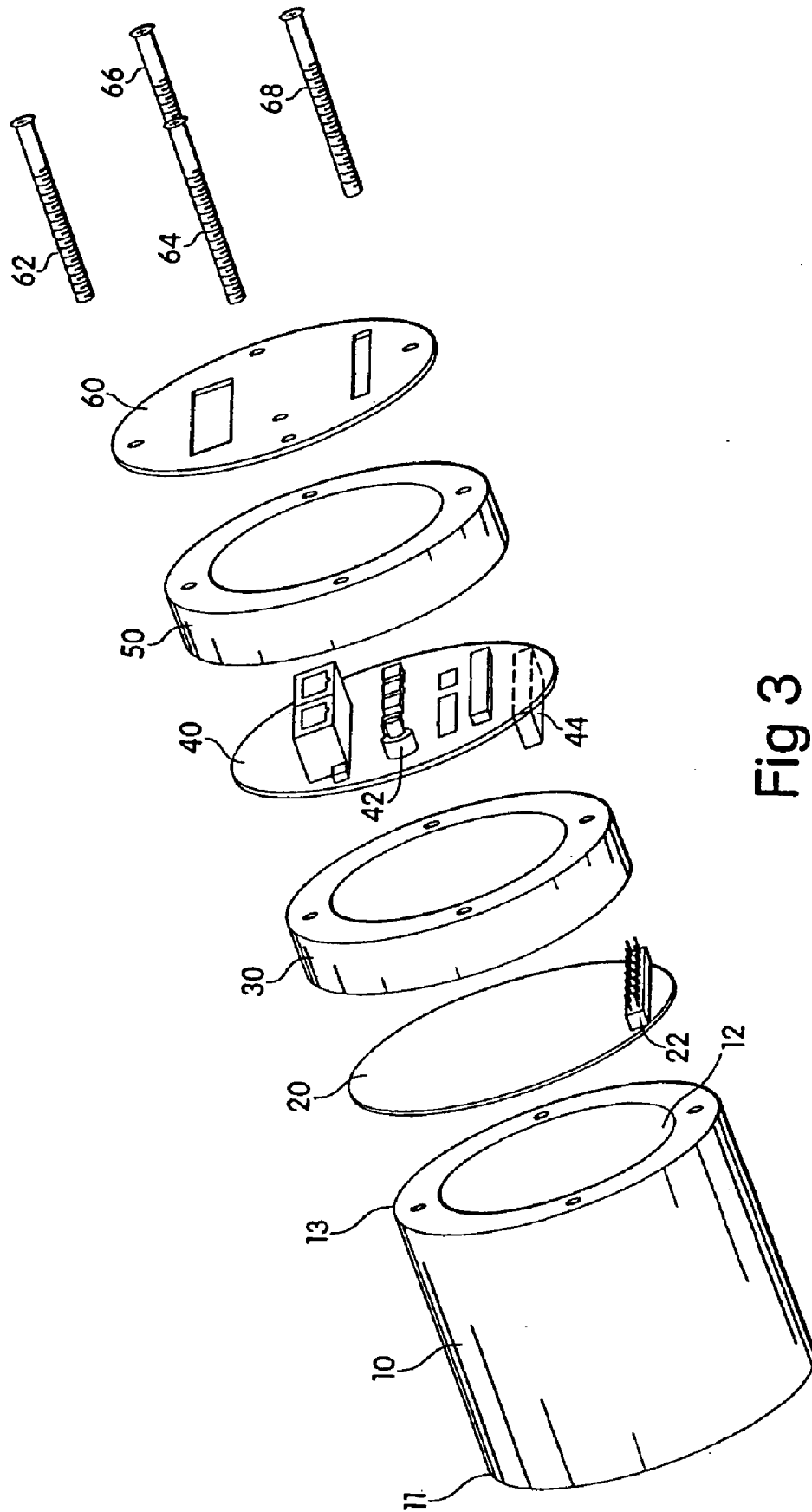

Fig 3

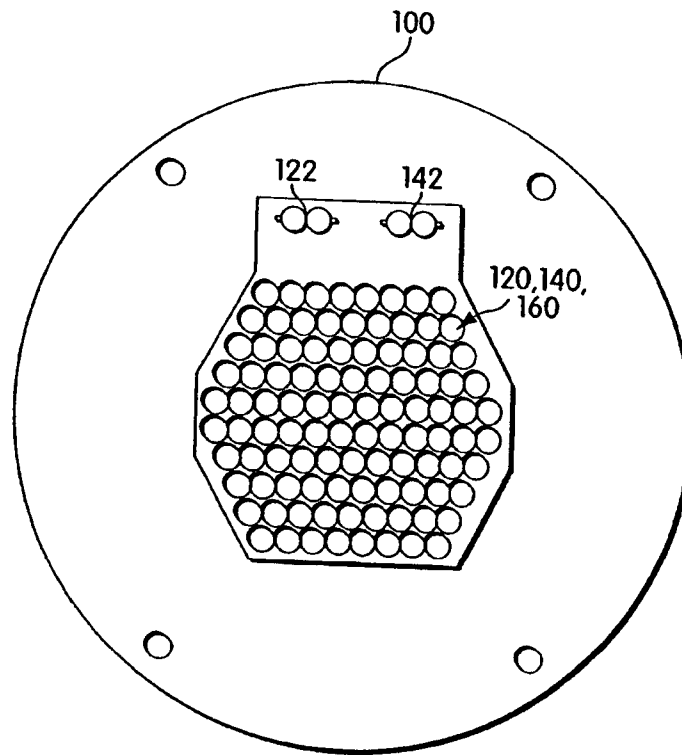

Fig. 4

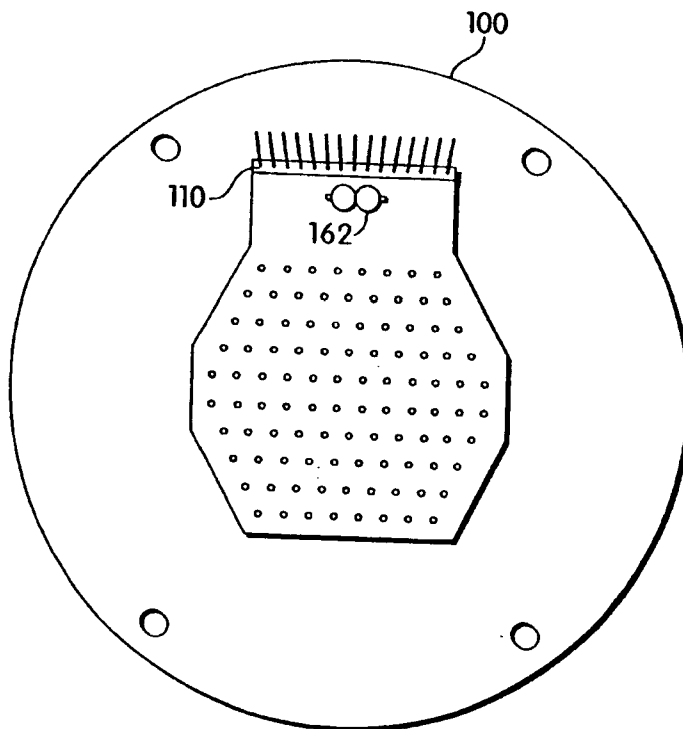

Fig. 5

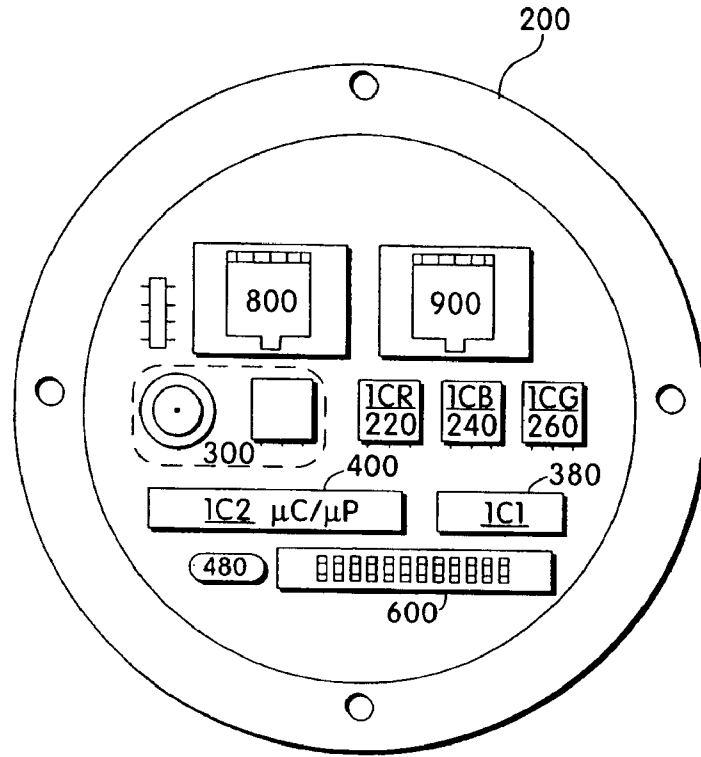

Fig. 6

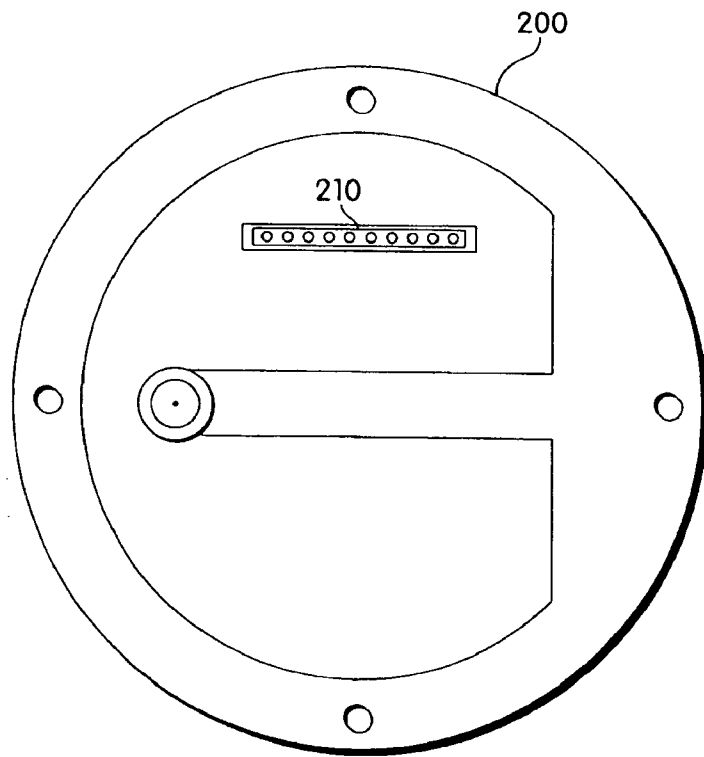

Fig. 7

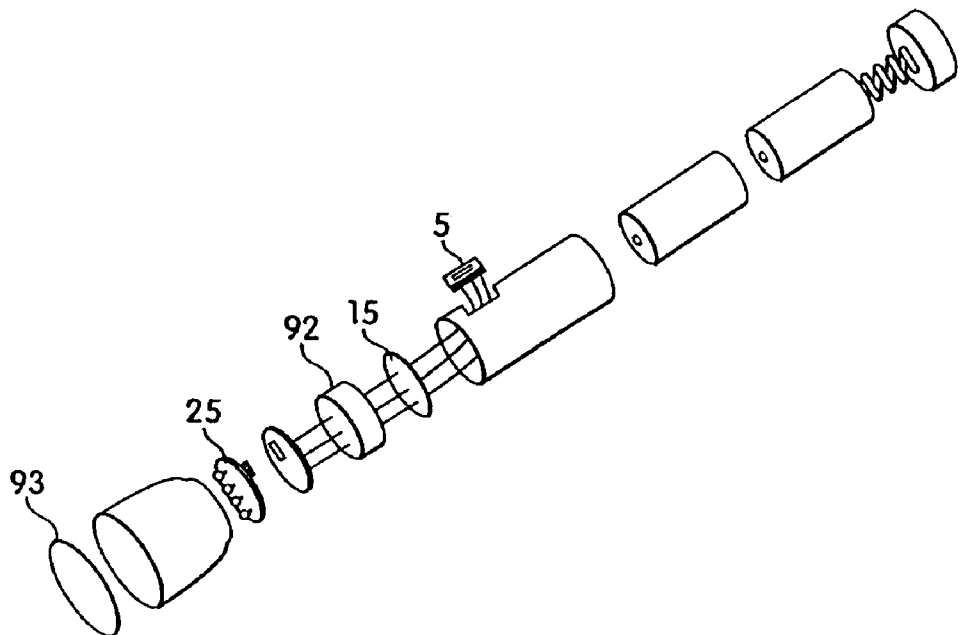

Fig. 8

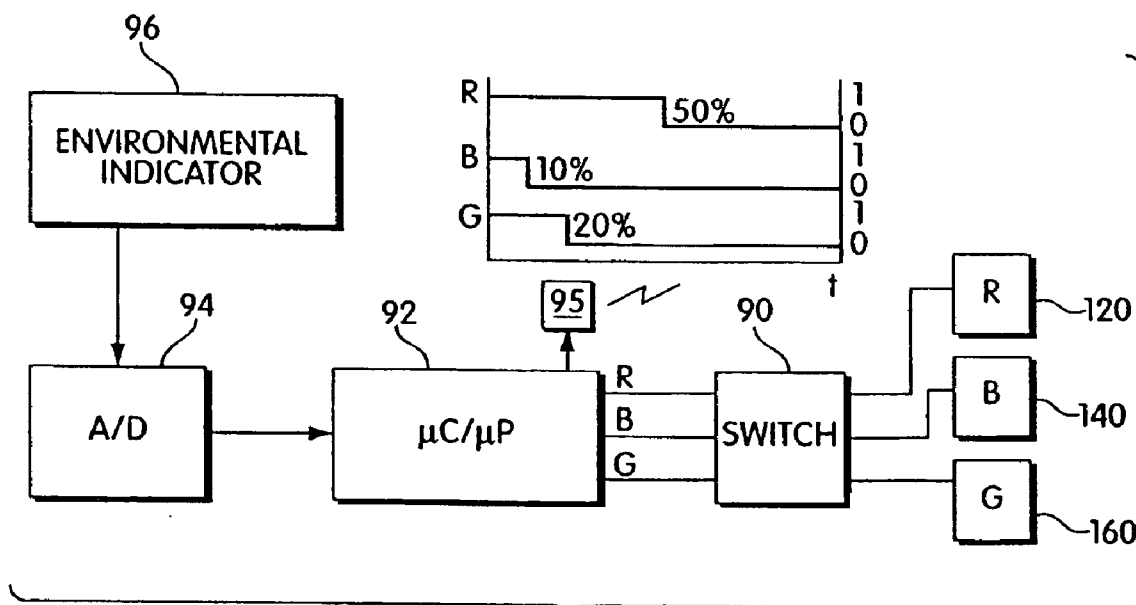

Fig. 9

MULTICOLORED LIGHTING METHOD AND APPARATUS

CROSS REFERENCES TO RELATED APPLICATIONS

This application is a continuation of U.S. application Ser. No. 09/971,367, filed on Oct. 4, 2001 now U.S. Pat. No. 6,788,011, which is a continuation of U.S. application Ser. No. 09/669,121, filed on Sep. 25, 2000 now U.S. Pat. No. 6,806,659, which is a continuation of U.S. application Ser. No. 09/425,770, filed Oct. 22, 1999, now U.S. Pat. No. 6,150,774, which is a continuation of U.S. application Ser. No. 08/920,156, filed Aug. 26, 1997, now U.S. Pat. No. 6,016,038.

BACKGROUND OF THE INVENTION

The present invention relates to providing light of a selectable color using LEDs. More particularly, the present invention is a method and apparatus for providing multicolored illumination. More particularly still, the present invention is an apparatus for providing a computer controlled multicolored illumination network capable of high performance and rapid color selection and change.

It is well known that combining the projected light of one color with the projected light of another color will result in the creation of a third color. It is also well known that the three most commonly used primary colors—red, blue and green—can be combined in different proportions to generate almost any color in the visible spectrum. The present invention takes advantage of these effects by combining the projected light from at least two light emitting diodes (LEDs) of different primary colors.

Computer lighting networks are not new. U.S. Pat. No. 5,420,482, issued to Phares, describes one such network that uses different colored LEDs to generate a selectable color. Phares is primarily for use as a display apparatus. However, the apparatus has several disadvantages and limitations. First, each of the three color LEDs in Phares is powered through a transistor biasing scheme in which the transistor base is coupled to a respective latch register through biasing resistors. The three latches are all simultaneously connected to the same data lines on the data bus. This means it is impossible in Phares to change all three LED transistor biases independently and simultaneously. Also, biasing of the transistors is inefficient because power delivered to the LEDs is smaller than that dissipated in the biasing network. This makes the device poorly suited for efficient illumination applications. The transistor biasing used by Phares also makes it difficult, if not impossible, to interchange groups of LEDs having different power ratings, and hence different intensity levels.

U.S. Pat. No. 4,845,481, issued to Havel, is directed to a multicolored display device. Havel addresses some, but not all of the switching problems associated with Phares. Havel uses a pulse width modulated signal to provide current to respective LEDs at a particular duty cycle. However, no provision is made for precise and rapid control over the colors emitted. As a stand alone unit, the apparatus in Havel suggests away from network lighting, and therefore lacks any teaching as to how to implement a pulse width modulated computer lighting network. Further, Havel does not appreciate the use of LEDs beyond mere displays, such as for illumination.

U.S. Pat. No. 5,184,114, issued to Brown, shows an LED display system. But Brown lacks any suggestion to use LEDs for illumination, or to use LEDs in a configurable

computer network environment. U.S. Pat. No. 5,134,387, issued to Smith et al., directed to an LED matrix display, contains similar problems. Its rudimentary current control scheme severely limits the possible range of colors that can be displayed.

It is an object of the present invention to overcome the limitations of the prior art by providing a high performance computer controlled multicolored LED lighting network.

It is a further object of the present invention to provide a unique LED lighting network structure capable of both a linear chain of nodes and a binary tree configuration.

It is still another object of the present invention to provide a unique heat-dissipating housing to contain the lighting units of the lighting network.

It is yet another object of the present invention to provide a current regulated LED lighting apparatus, wherein the apparatus contains lighting modules each having its own maximum current rating and each conveniently interchangeable with one another.

It is a still further object of the present invention to provide a unique computer current-controlled LED lighting assembly for use as a general illumination device capable of emitting multiple colors in a continuously programmable 24-bit spectrum.

It is yet a still further object of the present invention to provide a unique flashlight, inclinometer, thermometer, general environmental indicator and lightbulb, all utilizing the general computer current-control principles of the present invention.

Other objects of the present invention will be apparent from the detailed description below.

SUMMARY OF THE INVENTION

In brief, the invention herein comprises a pulse width modulated current control for an LED lighting assembly, where each current-controlled unit is uniquely addressable and capable of receiving illumination color information on a computer lighting network. In a further embodiment, the invention includes a binary tree network configuration of lighting units (nodes). In another embodiment, the present invention comprises a heat dissipating housing, made out of a heat-conductive material, for housing the lighting assembly. The heat dissipating housing contains two stacked circuit boards holding respectively the power module and the light module. The light module is adapted to be conveniently interchanged with other light modules having programmable current, and hence maximum light intensity ratings. Other embodiments of the present invention involve novel applications for the general principles described herein.

DESCRIPTION OF THE DRAWINGS

FIG. 1 is a stylized electrical circuit schematic of the light module of the present invention.

FIG. 2 is a stylized electrical circuit schematic of the power module of the present invention.

FIG. 2A illustrates a network of addressable LED-based lighting units according to one embodiment of the invention.

FIG. 3 is an exploded view of the housing of one of the embodiments of the present invention.

FIG. 4 is a plan view of the LED-containing side of the light module of the present invention.

FIG. 5 is a plan view of the electrical connector side of the light module of the present invention.

FIG. 6 is a plan view of the power terminal side of the power module of the present invention.

FIG. 7 is a plan view of the electrical connector side of the power module of the present invention.

FIG. 8 is an exploded view of a flashlight assembly containing the LED lighting module of the present invention.

FIG. 9 is a control block diagram of the environmental indicator of the present invention.

DETAILED DESCRIPTION

The structure and operation of a preferred embodiment will now be described. It should be understood that many other ways of practicing the inventions herein are available, and the embodiments described herein are exemplary and not limiting. Turning to FIG. 1, shown is an electrical schematic representation of a light module 100 of the present invention. FIGS. 4 and 5 show the LED-containing side and the electrical connector side of light module 100. Light module 100 is self-contained, and is configured to be a standard item interchangeable with any similarly constructed light module. Light module 100 contains a ten-pin electrical connector 110 of the general type. In this embodiment, the connector 110 contains male pins adapted to fit into a complementary ten-pin connector female assembly, to be described below. Pin 180 is the power supply. A source of DC electrical potential enters module 100 on pin 180. Pin 180 is electrically connected to the anode end of light emitting diode (LED) sets 120, 140 and 160 to establish a uniform high potential on each anode end.

LED set 120 contains red LEDs, set 140 contains blue and set 160 contains green, each obtainable from the Nichia America Corporation. These LEDs are primary colors, in the sense that such colors when combined in preselected proportions can generate any color in the spectrum. While three primary colors is preferred, it will be understood that the present invention will function nearly as well with only two primary colors to generate any color in the spectrum. Likewise, while the different primary colors are arranged herein on sets of uniformly colored LEDs, it will be appreciated that the same effect may be achieved with single LEDs containing multiple color-emitting semiconductor dies. LED sets 120, 140 and 160 each preferably contains a serial/parallel array of LEDs in the manner described by Okuno in U.S. Pat. No. 4,298,869, incorporated herein by reference. In the present embodiment, LED set 120 contains three parallel connected rows of nine red LEDs (not shown), and LED sets 140 and 160 each contain five parallel connected rows of five blue and green LEDs, respectively (not shown). It is understood by those in the art that, in general, each red LED drops the potential in the line by a lower amount than each blue or green LED, about 2.1 V, compared to 4.0 V, respectively, which accounts for the different row lengths. This is because the number of LEDs in each row is determined by the amount of voltage drop desired between the anode end at the power supply voltage and the cathode end of the last LED in the row. Also, the parallel arrangement of rows is a fail-safe measure that ensures that the light module 100 will still function even if a single LED in a row fails, thus opening the electrical circuit in that row. The cathode ends of the three parallel rows of nine red LEDs in LED set 120 are then connected in common, and go to pin 128 on connector 110. Likewise, the cathode ends of the five parallel rows of five blue LEDs in LED set 140 are connected in common, and go to pin 148 on connector 110. The cathode ends of the five parallel rows of five green LEDs in

LED set 160 are connected in common, and go to pin 168 on connector 110. Finally, on light module 100, each LED set is associated with a programming resistor that combines with other components, described below, to program the maximum current through each set of LEDs. Between pin 124 and 126 is resistor 122, 6.2. Between pin 144 and 146 is resistor 142, 4.7. Between pin 164 and 166 is resistor 162, 4.7. Resistor 122 programs maximum current through red LED set 120, resistor 142 programs maximum current through blue LED set 140, and resistor 162 programs maximum current through green LED set 160. The values these resistors should take are determined empirically, based on the desired maximum light intensity of each LED set. In the present embodiment, the resistances above program red, blue and green currents of 70, 50 and 50 A, respectively.

With the electrical structure of light module 100 described, attention will now be given to the electrical structure of power module 200, shown in FIG. 2. FIGS. 6 and 7 show the power terminal side and electrical connector side of an embodiment of power module 200. Like light module 100, power module 200 is self contained. Interconnection with male pin set 110 is achieved through complementary female pin set 210. Pin 280 connects with pin 180 for supplying power, delivered to pin 280 from supply 300. Supply 300 is shown as a functional block for simplicity. In actuality, supply 300 can take numerous forms for generating a DC voltage. In the present embodiment, supply 300 provides 24 Volts through a connection terminal (not shown), coupled to pin 280 through transient protection capacitors (not shown) of the general type. It will be appreciated that supply 300 may also supply a DC voltage after rectification and/or voltage transformation of an AC supply, as described more fully in U.S. Pat. No. 4,298,869.

Also connected to pin connector 210 are three current programming integrated circuits, ICR 220, ICB 240 and ICG 260. Each of these is a three terminal adjustable regulator, preferably part number LM317B, available from the National Semiconductor Corporation, Santa Clara, Calif. The teachings of the LM317 datasheet are incorporated herein by reference. Each regulator contains an input terminal, an output terminal and an adjustment terminal, labeled I, O and A, respectively. The regulators function to maintain a constant maximum current into the input terminal and out of the output terminal. This maximum current is pre-programmed by setting a resistance between the output and the adjustment terminals. This is because the regulator will cause the voltage at the input terminal to settle to whatever value is needed to cause 1.25 V to appear across the fixed current set resistor, thus causing constant current to flow. Since each functions identically, only ICR 220 will now be described. First, current enters the input terminal of ICR 220 from pin 228. Of course, pin 228 in the power module is coupled to pin 128 in the light module, and receives current directly from the cathode end of the red LED set 120. Since resistor 122 is ordinarily disposed between the output and adjustment terminals of ICR 220 through pins 224/124 and 226/126, resistor 122 programs the amount of current regulated by ICR 220. Eventually, the current output from the adjustment terminal of ICR 220 enters a Darlington driver. In this way, ICR 220 and associated resistor 122 program the maximum current through red LED set 120. Similar results are achieved with ICB 240 and resistor 142 for blue LED set 140, and with ICG 260 and resistor 162 for green LED set 160.

The red, blue and green LED currents enter another integrated circuit, IC1 380, at respective nodes 324, 344 and 364. IC1 380 is preferably a high current/voltage Darlington

driver, part no. DS2003 available from the National Semiconductor Corporation, Santa Clara, Calif. IC1 380 is used as a current sink, and functions to switch current between respective LED sets and ground 390. As described in the DS2003 datasheet, incorporated herein by reference, IC1 5 contains six sets of Darlington transistors with appropriate on-board biasing resistors. As shown, nodes 324, 344 and 364 couple the current from the respective LED sets to three pairs of these Darlington transistors, in the well known manner to take advantage of the fact that the current rating of IC1 380 may be doubled by using pairs of Darlington transistors to sink respective currents. Each of the three on-board Darlington pairs is used in the following manner as a switch. The base of each Darlington pair is coupled to signal inputs 424, 444 and 464, respectively. Hence, input 424 is the signal input for switching current through node 324, and thus the red LED set 120. Input 444 is the signal input for switching current through node 344, and thus the blue LED set 140. Input 464 is the signal input for switching current through node 364, and thus the green LED set 160. Signal inputs 424, 444 and 464 are coupled to respective signal outputs 434, 454 and 474 on microcontroller IC2 400, as described below. In essence, when a high frequency square wave is incident on a respective signal input, IC1 380 switches current through a respective node with the identical frequency and duty cycle. Thus, in operation, the states of signal inputs 424, 444 and 464 directly correlate with the opening and closing of the power circuit through respective LED sets 120, 140 and 160.

The structure and operation of microcontroller IC2 400 will now be described. Microcontroller IC2 400 is preferably a MICROCHIP brand PIC16C63, although almost any properly programmed microcontroller or microprocessor can perform the software functions described herein. The main function of microcontroller IC2 400 is to convert numerical data received on serial Rx pin 520 into three independent high frequency square waves of uniform frequency but independent duty cycles on signal output pins 434, 454 and 474. The FIG. 2 representation of microcontroller IC2 400 is partially stylized, in that persons of skill in the art will appreciate that certain of the twenty-eight standard pins have been omitted or combined for greatest clarity.

Microcontroller IC2 400 is powered through pin 450, which is coupled to a 5 Volt source of DC power 700. Source 700 is preferably driven from supply 300 through a coupling (not shown) that includes a voltage regulator (not shown). An exemplary voltage regulator is the LM340 3-terminal positive regulator, available from the National Semiconductor Corporation, Santa Clara, Calif. The teachings of the LM340 datasheet are hereby incorporated by reference. Those of skill in the art will appreciate that most microcontrollers, and many other independently powered digital integrated circuits, are rated for no more than a 5 Volt power source. The clock frequency of microcontroller IC2 400 is set by crystal 480, coupled through appropriate pins. Pin 490 is the microcontroller IC2 400 ground reference.

Switch 600 is a twelve position dip switch that may be alterably and mechanically set to uniquely identify the microcontroller IC2 400. When individual ones of the twelve mechanical switches within dip switch 600 are closed, a path is generated from corresponding pins 650 on microcontroller IC2 400 to ground 690. Twelve switches create 2^{12} possible settings, allowing any microcontroller IC2 400 to take on one of 4096 different IDs, or addresses. In the preferred embodiment, only nine switches are actually used because the DMX-512 protocol, discussed below, is employed.

Once switch 600 is set, microcontroller IC2 400 “knows” its unique address (“who am I”), and “listens” on serial line 520 for a data stream specifically addressed to it. A high speed network protocol, preferably a DMX protocol, is used to address network data to each individually addressed microcontroller IC2 400 from a central network controller 1000, as shown for example in FIG. 2A. The DMX protocol is described in a United States Theatre Technology, Inc. publication entitled “DMX512/1990 Digital Data Transmission Standard for Dimmers and Controllers,” incorporated herein by reference. Basically, in the network protocol used herein, a central controller creates a stream of network data consisting of sequential data packets. Each packet first contains a header, which is checked for conformance to the standard and discarded, followed by a stream of sequential bytes representing data for sequentially addressed devices. For instance, if the data packet is intended for light number fifteen, then fourteen bytes from the data stream will be discarded, and the device will save byte number fifteen. If as in the preferred embodiment, more than one byte is needed, then the address is considered to be a starting address, and more than one byte is saved and utilized. Each byte corresponds to a decimal number 0 to 255, linearly representing the desired intensity from Off to Full. (For simplicity, details of the data packets such as headers and stop bits are omitted from this description, and will be well appreciated by those of skill in the art.) This way, each of the three LED colors is assigned a discrete intensity value between 0 and 255. These respective intensity values are stored in respective registers within the memory of microcontroller IC2 400 (not shown). Once the central controller exhausts all data packets, it starts over in a continuous refresh cycle. The refresh cycle is defined by the standard to be a minimum of 1196 microseconds, and a maximum of 1 second.

Microcontroller IC2 400 is programmed continually to “listen” for its data stream. When microcontroller IC2 400 is “listening,” but before it detects a data packet intended is for it, it is running a routine designed to create the square wave signal outputs on pins 434, 454 and 474. The values in the color registers determine the duty cycle of the square wave. Since each register can take on a value from 0 to 255, these values create 256 possible different duty cycles in a linear range from 0% to 100%. Since the square wave frequency is uniform and determined by the program running in the microcontroller IC2 400, these different discrete duty cycles represent variations in the width of the square wave pulses. This is known as pulse width modulation (PWM).

The PWM interrupt routine is implemented using a simple counter, incrementing from 0 to 255 in a cycle during each period of the square wave output on pins 434, 454 and 474. When the counter rolls over to zero, all three signals are set high. Once the counter equals the register value, signal output is changed to low. When microcontroller IC2 400 receives new data, it freezes the counter, copies the new data to the working registers, compares the new register values with the current count and updates the output pins accordingly, and then restarts the counter exactly where it left off. Thus, intensity values may be updated in the middle of the PWM cycle. Freezing the counter and simultaneously updating the signal outputs has at least two advantages. First, it allows each lighting unit to quickly pulse/strobe as a strobe light does. Such strobing happens when the central controller sends network data having high intensity values alternately with network data having zero intensity values at a rapid rate. If one restarted the counter without first updating the signal outputs, then the human eye would be able to perceive the staggered deactivation of each indi-

vidual color LED that is set at a different pulse width. This feature is not of concern in incandescent lights because of the integrating effect associated with the heating and cooling cycle of the illumination element. LEDs, unlike incandescent elements, activate and deactivate essentially instantaneously in the present application. The second advantage is that one can “dim” the LEDs without the flickering that would otherwise occur if the counter were reset to zero. The central controller can send a continuous dimming signal when it creates a sequence of intensity values representing a uniform and proportional decrease in light intensity for each color LED. If one did not update the output signals before restarting the counter, there is a possibility that a single color LED will go through nearly two cycles without experiencing the zero current state of its duty cycle. For instance, assume the red register is set at 4 and the counter is set at 3 when it is frozen. Here, the counter is frozen just before the “off” part of the PWM cycle is to occur for the red LEDs. Now assume that the network data changes the value in the red register from 4 to 2 and the counter is restarted without deactivating the output signal. Even though the counter is greater than the intensity value in the red register, the output state is still “on”, meaning that maximum current is still flowing through the red LEDs. Meanwhile, the blue and green LEDs will probably turn off at their appropriate times in the PWM cycle. This would be perceived by the human eye as a red flicker in the course of dimming the color intensities. Freezing the counter and updating the output for the rest of the PWM cycle overcomes these disadvantages, ensuring the flicker does not occur.

The network interface for microcontroller IC2 400 will now be described. Jacks 800 and 900 are standard RJ-8 network jacks. Jack 800 is used as an input jack, and is shown for simplicity as having only three inputs: signal inputs 860, 870 and ground 850. Network data enters jack 800 and passes through signal inputs 860 and 870. These signal inputs are then coupled to IC3 500, which is an RS-485/RS422 differential bus repeater of the standard type, preferably a DS96177 from the National Semiconductor Corporation, Santa Clara, Calif. The teachings of the DS96177 datasheet are hereby incorporated by reference. The signal inputs 860, 870 enter IC3 500 at pins 560, 570. The data signal is passed through from pin 510 to pin 520 on microcontroller IC2 400. The same data signal is then returned from pin 540 on IC2 400 to pin 530 on IC3 500. Jack 900 is used as an output jack and is shown for simplicity as having only five outputs: signal outputs 960, 970, 980, 990 and ground 950. Outputs 960 and 970 are split directly from input lines 860 and 870, respectively. Outputs 980 and 990 come directly from IC3 500 pins 580 and 590, respectively. It will be appreciated that the foregoing assembly enables two network nodes to be connected for receiving the network data. Thus, a network may be constructed as a daisy chain, if only single nodes are strung together, or as a binary tree, if two nodes are attached to the output of each single node.

From the foregoing description, one can see that an addressable network of LED illumination or display units 2000 as shown in FIG. 2A can be constructed from a collection of power modules each connected to a respective light module. As long as at least two primary color LEDs are used, any illumination or display color may be generated simply by preselecting the light intensity that each color emits. Further, each color LED can emit light at any of 255 different intensities, depending on the duty cycle of PWM square wave, with a full intensity pulse generated by passing maximum current through the LED. Further still, the maxi-

imum intensity can be conveniently programmed simply by adjusting the ceiling for the maximum allowable current using programming resistances for the current regulators residing on the light module. Light modules of different maximum current ratings may thereby be conveniently interchanged.

The foregoing embodiment may reside in any number of different housings. A preferred housing for an illumination unit is described. Turning now to FIG. 3, there is shown an exploded view of an illumination unit of the present invention comprising a substantially cylindrical body section 10, a light module 20, a conductive sleeve 30, a power module 40, a second conductive sleeve 50 and an enclosure plate 60. It is to be assumed here that the light module 20 and the power module 40 contain the electrical structure and software of light module 100 and power module 200, described above. Screws 62, 64, 66, 68 allow the entire apparatus to be mechanically connected. Body section 10, conductive sleeves 30 and 50 and enclosure plate 60 are preferably made from a material that conducts heat, most preferably aluminum. Body section 10 has an open end 10, a reflective interior portion 12 and an illumination end 13, to which module 20 is mechanically affixed. Light module 20 is disk shaped and has two sides. The illumination side (not shown) comprises a plurality of LEDs of different primary colors. The connection side holds an electrical connector male pin assembly 22. Both the illumination side and the connection side are coated with aluminum surfaces to better allow the conduction of heat outward from the plurality of LEDs to the body section 10. Likewise, power module 40 is disk shaped and has every available surface covered with aluminum for the same reason. Power module 40 has a connection side holding an electrical connector female pin assembly 44 adapted to fit the pins from assembly 22. Power module 40 has a power terminal side holding a terminal 42 for connection to a source of DC power. Any standard AC or DC jack may be used, as appropriate.

Interposed between light module 20 and power module 40 is a conductive aluminum sleeve 30, which substantially encloses the space between modules 20 and 40. As shown, a disk-shaped enclosure plate 60 and screws 62, 64, 66 and 68 sad all of the components together, and conductive sleeve 50 is thus interposed between enclosure plate 60 and power module 40. Once sealed together as a unit, the illumination apparatus may be connected to a data network as described above and mounted in any convenient manner to illuminate an area. In operation, preferably a light diffusing means will be inserted in body section 10 to ensure that the LEDs on light module 20 appear to emit a single uniform frequency of light.

From the foregoing, it will be appreciated that PWM current control of LEDs to produce multiple colors may be incorporated into countless environments, with or without networks. For instance, FIG. 8 shows a hand-held flashlight can be made to shine any conceivable color using an LED assembly of the present invention. The flashlight contains an external adjustment means 5, that may be for instance a set of three potentiometers coupled to an appropriately programmed microcontroller 92 through respective A/D conversion means 15. Each potentiometer would control the current duty cycle, and thus the illumination intensity, of an individual color LED on LED board 25. With three settings each capable of generating a different byte from 0 to 255, a computer-controlled flashlight may generate twenty-four bit color. Of course, three individual potentiometers can be incorporated into a single device, such as a track ball or joystick, so as to be operable as a single adjuster. Further, it

is not necessary that the adjustment means must be a potentiometer. For instance, a capacitive or resistive thumb plate may also be used to program the two or three registers necessary to set the color. A lens assembly 93 may be provided for reflecting the emitted light. A non-hand held embodiment of the present invention may be used as an underwater swimming pool light. Since the present invention can operate at relatively low voltages and low current, it is uniquely suited for safe underwater operation.

Similarly, the present invention may be used as a general indicator of any given environmental condition. FIG. 9 shows the general functional block diagram for such an apparatus. Shown within FIG. 9 is also an exemplary chart showing the duty cycles of the three color LEDs during an exemplary period. As one example of an environmental indicator 96, the power module can be coupled to an inclinometer. The inclinometer measures general angular orientation with respect to the earth's center of gravity. The inclinometer's angle signal can be converted through an A/D converter 94 and coupled to the data inputs of the microcontroller 92 in the power module. The microcontroller 92 can then be programmed to assign each discrete angular orientation a different color through the use of a lookup table associating angles with LED color register values. A current switch 90, coupled to the microcontroller 92, may be used to control the current supply to LEDs 120, 140, and 160 of different colors. The microcontroller 92 may be coupled to a transceiver 95 for transmitting and receiving signals. The "color inclinometer" may be used for safety, such as in airplane cockpits, or for novelty, such as to illuminate the sails on a sailboat that sways in the water. Another indicator use is to provide an easily readable visual temperature indication. For example, a digital thermometer can be connected to provide the microcontroller a temperature reading. Each temperature will be associated with a particular set of register values, and hence a particular color output. A plurality of such "color thermometers" can be located over a large space, such as a storage freezer, to allow simple visual inspection of temperature over three dimensions.

Another use of the present invention is as a lightbulb. Using appropriate rectifier and voltage transformation means, the entire power and light modules may be placed in an Edison-mount (screw-type) lightbulb housing. Each bulb can be programmed with particular register values to deliver a particular color bulb, including white. The current regulator can be pre-programmed to give a desired current rating and thus preset light intensity. Naturally, the lightbulb will have a transparent or translucent section that allows the passage of light into the ambient.

While the foregoing has been a detailed description of the preferred embodiment of the invention, the claims which follow define more freely the scope of invention to which applicant is entitled. Modifications or improvements which may not come within the explicit language of the claims described in the preferred embodiments should be treated as within the scope of invention insofar as they are equivalent or otherwise consistent with the contribution over the prior art and such contribution is not to be limited to specific embodiments disclosed.

What is claimed is:

1. An illumination apparatus, comprising:

a first number of first light sources adapted to generate first radiation having a first spectrum;

a second number of second light sources adapted to generate second radiation having a second spectrum different than the first spectrum, wherein the first number and the second number are different;

at least one structure coupled to the first number of first light sources and the second number of second light sources so as to facilitate a mixing of the first radiation and the second radiation; and

at least one controller coupled to the first number of first light sources and the second number of second light sources and configured to independently control at least a first intensity of the first radiation and a second intensity of the second radiation so as to controllably vary at least an overall perceivable color of the visible radiation generated by the illumination apparatus,

wherein the apparatus is configured to provide ambient illumination including visible radiation in an environment to be occupied by an observer of the ambient illumination, the visible radiation including at least one of the first radiation and the second radiation, and

wherein the at least one controller is configured as an addressable controller capable of receiving at least one network signal including at least first lighting information relating to the overall perceivable color of the visible radiation generated by the illumination apparatus.

2. The apparatus of claim 1, wherein the at least one controller is configured to control the first light sources and the second light sources irrespective of any imaging of the ambient illumination.

3. The illumination apparatus of claim 1, wherein the at least one controller is configured to generate a first control signal to control all of the first light sources substantially identically, and a second control signal to control all of the second light sources substantially identically.

4. The illumination apparatus of claim 1, wherein the at least one controller is configured to independently control at least the first intensity of the first radiation and the second intensity of the second radiation using a pulse width modulation (PWM) technique.

5. The illumination apparatus of claim 4, wherein the at least one controller is configured to generate a first PWM control signal to control all of the first light sources substantially identically, and a second PWM control signal to control all of the second light sources substantially identically.

6. The illumination apparatus of claim 1, wherein each light source of the first and second light sources is an LED.

7. The apparatus of claim 1, wherein the at least one controller is configured to control the first light sources and the second light sources irrespective of a motion of any object in the environment to be occupied by the observer.

8. The illumination apparatus of claim 1, wherein the at least one network signal includes address information and lighting information for a plurality of illumination apparatus, and wherein the at least one controller is configured to process the at least one network signal based on at least the address information in the at least one network signal to recover the first lighting information.

9. The illumination apparatus of claim 1, wherein the at least one network signal is formatted using a DMX protocol, and wherein the at least one controller is configured to independently control at least the first intensity of the first radiation and the second intensity of the second radiation based at least in part on the DMX protocol.

10. The illumination apparatus of claim 1, wherein each light source of the first and second light sources is an LED, and wherein

the at least one controller is configured to control at least a first intensity of the first radiation and a second intensity of the second radiation such that an overall

11

perceivable color of the visible radiation generated by the apparatus is white.

11. The illumination apparatus of claim 10, further comprising at least one power connection coupled to the at least one controller, the at least one power connection configured to engage mechanically and electrically with a conventional light socket.

12. The illumination apparatus of claim 11, wherein the at least one power connection includes an Edison screw-type power connection.

13. The illumination apparatus of claim 11, wherein the at least one structure is configured to resemble at least one type of conventional light bulb.

14. The illumination apparatus of claim 13, wherein the at least one structure is configured to resemble an Edison-mount light bulb housing.

15. The illumination apparatus of claim 13, wherein the at least one controller is configured to independently control at least the first intensity of the first radiation and the second intensity of the second radiation so as to controllably vary the overall perceivable color of the visible radiation generated by the illumination apparatus.

16. The illumination apparatus of claim 15, further comprising at least one user interface coupled to the at least one controller and configured to facilitate an adjustment of the overall perceivable color of the visible radiation generated by the illumination apparatus.

17. The illumination apparatus of claim 15, further comprising at least one sensor coupled to the at least one controller and configured to generate at least one control signal in response to at least one detectable condition, wherein the at least one controller is configured to control the overall perceivable color of the visible radiation generated by the illumination apparatus in response to the at least one control signal.

18. The illumination apparatus of claim 15, further comprising at least one of a receiver and a transmitter coupled to the at least one controller and configured to communicate at least one control signal to or from the illumination apparatus.

19. The illumination apparatus of claim 15, wherein the at least one controller is configured to independently control at least the first intensity of the first radiation and the second intensity of the second radiation using a pulse width modulation (PWM) technique.

20. The illumination apparatus of claim 15, wherein the at least one controller is configured as an addressable controller capable of receiving at least one network signal including at least first lighting information relating to the overall perceivable color of the visible radiation generated by the illumination apparatus.

21. The illumination apparatus of claim 20, wherein the at least one network signal includes address information and lighting information for a plurality of illumination apparatus, and wherein the at least one controller is configured to process the at least one network signal based on at least the address information in the at least one network signal to recover the first lighting information.

22. The illumination apparatus of claim 20, wherein the at least one network signal is formatted using a DMX protocol, and wherein the at least one controller is configured to independently control at least the first intensity of the first radiation and the second intensity of the second radiation based at least in part on the DMX protocol.

23. An illumination method, comprising acts of:

A) generating first radiation having a first spectrum from a plurality of first light sources;

12

B) generating second radiation having a second spectrum different than the first spectrum from a plurality of second light sources;

C) mixing at least a portion of the first radiation and a portion of the second radiation to provide visible radiation having an overall perceivable color;

D) receiving at least one addressed network signal including at least first lighting information relating to the overall perceivable color of the visible radiation; and

E) independently controlling at least a first intensity of the first radiation and a second intensity of the second radiation based at least in part on the first lighting information so as to controllably vary at least the overall perceivable color of the visible radiation,

wherein the act E) includes acts of:

E1) controlling all of the first light sources substantially identically; and

E2) controlling all of the second light sources substantially identically.

24. An illumination apparatus, comprising:

a first number of first LED light sources adapted to generate first radiation having a first spectrum;

a second number of second LED light sources adapted to generate second radiation having a second spectrum different than the first spectrum, wherein the first number and the second number are different;

at least one controller coupled to the first number of first light sources and the second number of second light sources and configured to control at least a first intensity of the first radiation and a second intensity of the second radiation such that an overall perceivable color of visible radiation generated by the apparatus is white; at least one power connection coupled to the at least one controller, the at least one power connection configured to engage mechanically and electrically with a conventional light socket; and

at least one of a housing and a mounting for the first and second light sources and the at least one controller, wherein the at least one of the housing and the mounting is configured to resemble at least one type of conventional light bulb,

wherein the at least one controller is configured to independently control at least the first intensity of the first radiation and the second intensity of the second radiation so as to controllably vary the overall perceivable color of the visible radiation generated by the illumination apparatus, and

wherein the at least one controller is configured as an addressable controller capable of receiving at least one network signal including at least first lighting information relating to the overall perceivable color of the visible radiation generated by the illumination apparatus.

25. An illumination method, comprising acts of:

A) generating first radiation having a first spectrum from a first number of first LED light sources;

B) generating second radiation having a second spectrum different than the first spectrum from a second number of second LED light sources, wherein the first number and the second number are different;

C) mixing at least a portion of the first radiation and a portion of the second radiation to provide visible radiation having an overall perceivable color;

D) controlling at least a first intensity of the first radiation and a second intensity of the second radiation such that the overall perceivable color of the visible radiation is white; and

13

- E) receiving at least one network signal including at least first lighting information relating to the overall perceivable color of the visible radiation,
 wherein the act D) includes an act of controlling at least the first intensity of the first radiation and the second intensity of the second radiation based at least in part on the first lighting information.
26. An illumination method, comprising acts of:
- A) generating first radiation having a first spectrum from a plurality of first light sources;
- B) generating second radiation having a second spectrum different than the first spectrum from a plurality of second light sources;
- C) coupling the first light sources and second light sources via an essentially planar inflexible substrate so as to provide ambient illumination including visible radiation in an environment to be occupied by an observer of the ambient illumination, the visible radiation including at least one of the first radiation and the second radiation;
- D) mixing at least a portion of the first radiation and a portion of the second radiation to provide an overall perceivable color of the visible radiation; and
- E) independently controlling at least a first intensity of the first radiation and a second intensity of the second radiation so as to controllably vary at least the overall perceivable color of the visible radiation,
 wherein the act E) includes acts of:
- E1) controlling all of the first light sources substantially identically; and
- E2) controlling all of the second light sources substantially identically, the method further comprising an act of:
- receiving at least one addressed network signal including at least first lighting information relating to the overall perceivable color of the visible radiation,
 wherein the act E) further includes an act of:
- independently controlling at least the first intensity of the first radiation and the second intensity of the second radiation based at least in part on the first lighting information.
27. The illumination method of claim 26, wherein respective numbers of the first light sources and the second light sources are different.
28. The illumination method of claim 26, wherein the act E) includes an act of:
- independently controlling at least the first intensity of the first radiation and the second intensity of the second radiation using a pulse width modulation (PWM) technique.
29. The illumination method of claim 26, wherein each light source of the first and second light sources is an LED.
30. The method of claim 26, wherein each light source of the first and second light sources is an LED, and wherein the act E) comprises an act of:
- E3) controlling at least the first intensity of the first radiation and the second intensity of the second radiation such that the overall perceivable color of the visible radiation is white.
31. The illumination method of claim 26, wherein the at least one network signal includes address information and lighting information for a plurality of illumination apparatus, and wherein the method further comprises an act of:
- processing the at least one network signal based on at least the address information in the at least one network signal to recover the first lighting information.

14

32. The illumination method of claim 26, wherein the at least one network signal is formatted using a DMX protocol, and wherein the act D) includes an act of:
- independently controlling at least the first intensity of the first radiation and the second intensity of the second radiation based at least in part on the DMX protocol.
33. The method of claim 30, wherein the first and second light sources are arranged as a package including at least one of a housing and a mounting, and wherein the method further comprises an act of:
- engaging the package mechanically and electrically with a conventional light socket.
34. The method of claim 30, further comprising an act of: adjusting the overall perceivable color of the visible radiation via at least one user interface.
35. The method of claim 30, further comprising an act of: controlling the overall perceivable color of the visible radiation in response to at least one detectable condition.
36. The method of claim 30, wherein the first and second light sources are arranged as a package including at least one of a housing and a mounting, and wherein the method further comprises an act of:
- communicating at least one control signal to or from the package.
37. The method of claim 30, wherein the act E3) includes an act of:
- independently controlling at least the first intensity of the first radiation and the second intensity of the second radiation using a pulse width modulation (PWM) technique.
38. The method of claim 30, further comprising an act of: receiving at least one network signal including at least first lighting information relating to the overall perceivable color of the visible radiation,
 wherein the act E3) includes an act of:
- independently controlling at least the first intensity of the first radiation and the second intensity of the second radiation based at least in part on the first lighting information.
39. The method of claim 38, wherein the at least one network signal includes address information and lighting information for a plurality of illumination apparatus, and wherein the method further includes an act of:
- processing the at least one network signal based on at least the address information in the at least one network signal to recover the first lighting information.
40. The method of claim 38, wherein the at least one network signal is formatted using a DMX protocol, and wherein the act E3) includes an act of:
- independently controlling at least the first intensity of the first radiation and the second intensity of the second radiation based at least in part on the DMX protocol.
41. An illumination method, comprising acts of:
- A) generating first radiation having a first spectrum from a first number of first light sources;
- B) generating second radiation having a second spectrum different than the first spectrum from a second number of second light sources, wherein the first number and the second number are different;
- C) mixing at least a portion of the first radiation and a portion of the second radiation so as to provide ambient illumination including visible radiation in an environment to be occupied by an observer of the ambient illumination, the visible radiation including at least one of the first radiation and the second radiation;

15

D) independently controlling at least a first intensity of the first radiation and a second intensity of the second radiation so as to controllably vary at least an overall perceivable color of the visible radiation; and receiving at least one addressed network signal including at least first lighting information relating to the overall perceivable color of the visible radiation, wherein the act D) includes an act of: independently controlling at least the first intensity of the first radiation and the second intensity of the second radiation based at least in part on the first lighting information.

42. The illumination method of claim 41, wherein the act D) includes acts of:

D1) controlling all of the first light sources substantially identically; and

D2) controlling all of the second light sources substantially identically.

43. The illumination method of claim 42, wherein the act D) includes an act of: independently controlling at least the first intensity of the first radiation and the second intensity of the second radiation using a pulse width modulation (PWM) technique so as to controllably vary at least the overall perceivable color of the visible radiation.

44. The illumination method of claim 42, wherein each light source of the first and second light sources is an LED.

45. The illumination method of claim 41, wherein the at least one network signal includes address information and lighting information for a plurality of illumination apparatus, and wherein the method further comprises an act of: processing the at least one network signal based on at least the address information in the at least one network signal to recover the first lighting information.

46. The method of claim 41, wherein each light source of the first and second light sources is an LED, and wherein the method further comprises an act of: D) controlling at least the first intensity of the first radiation and the second intensity of the second radiation such that an overall perceivable color of the visible radiation is white.

47. The method of claim 46, wherein the first and second light sources are arranged as a package including at least one of a housing and a mounting, and wherein the method further comprises an act of: E) engaging the package mechanically and electrically with a conventional light socket.

48. The method of claim 46, wherein the act D) includes an act of: D1) independently controlling at least the first intensity of the first radiation and the second intensity of the second radiation so as to controllably vary the overall perceivable color of the visible radiation.

49. The method of claim 48, further comprising an act of: adjusting the overall perceivable color of the visible radiation via at least one user interface.

50. The method of claim 48, further comprising an act of: controlling the overall perceivable color of the visible radiation in response to at least one detectable condition.

51. The method of claim 48, wherein the first and second light sources are arranged as a package including at least one of a housing and a mounting, and wherein the method further comprises an act of:

16

communicating at least one control signal to or from the package.

52. The method of claim 48, wherein the act D1) includes an act of: independently controlling at least the first intensity of the first radiation and the second intensity of the second radiation using a pulse width modulation (PWM) technique.

53. The method of claim 48, further comprising an act of: E) receiving at least one network signal including at least first lighting information relating to the overall perceivable color of the visible radiation, wherein the act D1) includes an act of: independently controlling at least the first intensity of the first radiation and the second intensity of the second radiation based at least in part on the first lighting information.

54. The method of claim 53, wherein the at least one network signal includes address information and lighting information for a plurality of illumination apparatus, and wherein the method further includes an act of: processing the at least one network signal based on at least the address information in the at least one network signal to recover the first lighting information.

55. The method of claim 54, wherein the at least one network signal is formatted using a DMX protocol, and wherein the act D1) includes an act of: independently controlling at least the first intensity of the first radiation and the second intensity of the second radiation based at least in part on the DMX protocol.

56. The illumination method of claim 41, wherein the at least one network signal is formatted using a DMX protocol, and wherein the act D) includes an act of: independently controlling at least the first intensity of the first radiation and the second intensity of the second radiation based at least in part on the DMX protocol.

57. The method of claim 41, further comprising wherein the act D) comprises an act of controlling the first LED light sources and the second LED light sources irrespective of a motion of any object in the environment to be occupied by the observer.

58. The method of claim 41, further comprising wherein the act D) comprises an act of controlling the first LED light sources and the second LED light sources irrespective of any imaging of the ambient illumination

59. An illumination apparatus, comprising: a plurality of first light sources adapted to generate first radiation having a first spectrum; a plurality of second light sources adapted to generate second radiation having a second spectrum different than the first spectrum; an essentially inflexible planar substrate on which all of the first light sources and all of the second light sources are mounted such that the apparatus is configured to provide ambient illumination including visible radiation in an environment to be occupied by an observer of the ambient illumination, the visible radiation including at least one of the first radiation and the second radiation; and at least one controller coupled to the plurality of first light sources and the plurality of second light sources and configured to independently control at least a first intensity of the first radiation and a second intensity of the second radiation so as to controllably vary at least an overall perceivable color of the visible radiation generated by the illumination apparatus,

wherein the at least one controller is configured to generate a first control signal to control all of the first light sources substantially identically, and a second control signal to control all of the second light sources substantially identically, and

wherein the at least one controller is configured as an addressable controller capable of receiving at least one network signal including at least first lighting information relating to the overall perceivable color of the visible radiation generated by the illumination apparatus.

60. The illumination apparatus of claim 59, wherein: each light source of the first and second light sources is an LED; and

the at least one controller is configured to control at least the first intensity of the first radiation and the second intensity of the second radiation such that the overall perceivable color of the visible radiation is white.

61. The illumination apparatus of claim 60, further comprising at least one power connection coupled to the at least one controller, the at least one power connection configured to engage mechanically and electrically with a conventional light socket.

62. The illumination apparatus of claim 61, further comprising at least one sensor coupled to the at least one controller and configured to generate at least one control signal in response to at least one detectable condition, wherein the at least one controller is configured to control the overall perceivable color of the visible radiation generated by the illumination apparatus in response to the at least one control signal.

63. The illumination apparatus of claim 61, further comprising at least one of a receiver and a transmitter coupled to the at least one controller and configured to communicate at least one control signal to or from the illumination apparatus.

64. The illumination apparatus of claim 61, wherein the at least one controller is configured to independently control at least the first intensity of the first radiation and the second intensity of the second radiation using a pulse width modulation (PWM) technique.

65. The illumination apparatus of claim 60, wherein the at least one controller is configured as an addressable controller capable of receiving at least one network signal including at least first lighting information relating to the overall perceivable color of the visible radiation generated by the illumination apparatus.

66. The illumination apparatus of claim 65, wherein the at least one network signal includes address information and lighting information for a plurality of illumination apparatus, and wherein the at least one controller is configured to process the at least one network signal based on at least the address information in the at least one network signal to recover the first lighting information.

67. The illumination apparatus of claim 65, wherein the at least one network signal is formatted using a DMX protocol, and wherein the at least one controller is configured to independently control at least the first intensity of the first radiation and the second intensity of the second radiation based at least in part on the DMX protocol.

68. The illumination apparatus of claim 61, wherein the at least one power connection includes an Edison screw-type power connection.

69. The illumination apparatus of claim 61, wherein the apparatus is configured to resemble at least one type of conventional light bulb.

70. The illumination apparatus of claim 69, further comprising a housing configured to resemble an Edison-mount light bulb housing.

71. The illumination apparatus of claim 61, further comprising at least one user interface coupled to the at least one controller and configured to facilitate an adjustment of the overall perceivable color of the visible radiation generated by the illumination apparatus.

72. The illumination apparatus of claim 59, wherein respective numbers of the first light sources and the second light sources are different.

73. The illumination apparatus of claim 59, wherein the at least one controller is configured to independently control at least the first intensity of the first radiation and the second intensity of the second radiation using a pulse width modulation (PWM) technique.

74. The illumination apparatus of claim 59, wherein each light source of the first and second light sources is an LED.

75. The illumination apparatus of claim 59, wherein the at least one network signal includes address information and lighting information for a plurality of illumination apparatus, and wherein the at least one controller is configured to process the at least one network signal based on at least the address information in the at least one network signal to recover the first lighting information.

76. The illumination apparatus of claim 59, wherein the at least one network signal is formatted using a DMX protocol, and wherein the at least one controller is configured to independently control at least the first intensity of the first radiation and the second intensity of the second radiation based at least in part on the DMX protocol.

77. An illumination apparatus, comprising:

a plurality of first LEDs adapted to generate first radiation having a first spectrum;

a plurality of second LEDs adapted to generate second radiation having a second spectrum different than the first spectrum;

an essentially inflexible planar substrate on which all of the first LEDs and all of the second LEDs are mounted; and

at least one controller coupled to the plurality of first LEDs and the plurality of second LEDs and configured to independently control at least a first intensity of the first radiation and a second intensity of the second radiation such that an overall perceivable color of visible radiation generated by the illumination apparatus is white,

wherein at least one controller is configured to independently control at least the first intensity of the first radiation and the second intensity of the second radiation so as to controllably vary the overall perceivable color of the visible radiation generated by the illumination apparatus, and

wherein the at least one controller is configured as an addressable controller capable of receiving at least one network signal including at least first lighting information relating to the overall perceivable color of the visible radiation generated by the illumination apparatus.

78. The illumination apparatus of claim 77, wherein the at least one controller is configured to generate a first control signal to control all of the first LEDs substantially identically, and a second control signal to control all of the second LEDs substantially identically.

79. The illumination apparatus of claim 77, wherein respective numbers of the first LEDs and the second LEDs are different.

80. The illumination apparatus of claim 77, further comprising at least one power connection coupled to the at least

19

one controller, the at least one power connection configured to engage mechanically and electrically with a conventional light socket.

81. The illumination apparatus of claim 80, wherein the at least one power connection includes an Edison screw-type power connection.

82. The illumination apparatus of claim 80, further comprising a housing for the respective pluralities of first and second LEDs and the at least one controller, wherein the housing is configured to resemble at least one type of conventional light bulb.

83. The illumination apparatus of claim 82, wherein the housing is configured to resemble an Edison-mount light bulb housing.

84. The illumination apparatus of claim 77, wherein the at least one network signal is formatted using a DMX protocol, and wherein the at least one controller is configured to independently control at least the first intensity of the first radiation and the second intensity of the second radiation based at least in part on the DMX protocol.

85. The illumination apparatus of claim 77, further comprising at least one user interface coupled to the at least one controller and configured to facilitate an adjustment of the overall perceivable color of the visible radiation generated by the illumination apparatus.

86. The illumination apparatus of claim 77, further comprising at least one sensor coupled to the at least one controller and configured to generate at least one control signal in response to at least one detectable condition, wherein the at least one controller is configured to control the overall perceivable color of the visible radiation generated by the illumination apparatus in response to the at least one control signal.

87. The illumination apparatus of claim 77, further comprising at least one of a receiver and a transmitter coupled to the at least one controller and configured to communicate at least one control signal to or from the illumination apparatus.

88. The illumination apparatus of claim 77, wherein the at least one controller is configured to independently control at least the first intensity of the first radiation and the second intensity of the second radiation using a pulse width modulation (PWM) technique.

89. The illumination apparatus of claim 88, wherein the at least one controller is configured to generate a first PWM control signal to control all of the first LEDs substantially identically, and a second PWM control signal to control all of the second LEDs substantially identically.

90. The illumination apparatus of claim 77, wherein the at least one network signal includes address information and lighting information for a plurality of illumination apparatus, and wherein the at least one controller is configured to process the at least one network signal based on at least the address information in the at least one network signal to recover the first lighting information.

91. An illumination apparatus, comprising:

a plurality of first LED light sources adapted to generate first radiation having a first spectrum;

a plurality of second LED light sources adapted to generate second radiation having a second spectrum different than the first spectrum;

at least one controller coupled to the plurality of first light sources and the plurality of second light sources and configured as an addressable controller capable of receiving at least one network signal including at least first lighting information relating to an overall perceivable color of visible radiation generated by the illumina-

20

tion apparatus, the at least one controller configured to control at least a first intensity of the first radiation and a second intensity of the second radiation based at least in part on the first lighting information, wherein: the at least one controller is configured to generate a first control signal to control all of the first light sources substantially identically and a second control signal to control all of the second light sources substantially identically; and

the at least one controller is configured to control at least the first intensity of the first radiation and the second intensity of the second radiation such that the overall perceivable color of the visible radiation is white; and

at least one power connection coupled to the at least one controller, the at least one power connection configured to engage mechanically and electrically with a conventional light socket.

92. An illumination method, comprising acts of:

A) generating first radiation having a first spectrum from a plurality of first LED light sources;

B) generating second radiation having a second spectrum different than the first spectrum from a plurality of second LED light sources;

C) mixing at least a portion of the first radiation and a portion of the second radiation to provide an overall perceivable color of the visible radiation;

D) receiving at least one network signal including at least first lighting information relating to the overall perceivable color of the visible radiation; and

E) controlling at least a first intensity of the first radiation and a second intensity of the second radiation based at least in part on the first lighting information,

wherein the act E) includes acts of:

controlling all of the first light sources substantially identically;

controlling all of the second light sources substantially identically; and

controlling at least the first intensity of the first radiation and the second intensity of the second radiation such that the overall perceivable color of the visible radiation is white.

93. An illumination method, comprising acts of:

A) generating first radiation having a first spectrum from a plurality of first LEDs;

B) generating second radiation having a second spectrum different than the first spectrum from a plurality of second LEDs;

C) mixing at least a portion of the first radiation and a portion of the second radiation to provide visible radiation having an overall perceivable color;

D) independently controlling at least a first intensity of the first radiation and a second intensity of the second radiation such that the overall perceivable color of the visible radiation is white; and

E) coupling the first light sources and second light sources via an essentially planar inflexible substrate,

wherein the act D) includes an act of:

D1) independently controlling at least the first intensity of the first radiation and the second intensity of the second radiation so as to controllably vary the overall perceivable color of the visible radiation,

the method further comprising an act of:

F) receiving at least one network signal including at least first lighting information relating to the overall perceivable color of the visible radiation,

wherein the act D1) includes an act of:
independently controlling at least the first intensity of the first radiation and the second intensity of the second radiation based at least in part on the first lighting information.

94. The method of claim 93, wherein the act D) includes acts of:

- controlling all of the first LEDs substantially identically; and
- controlling all of the second LEDs substantially identically.

95. The method of claim 93, wherein respective numbers of the first LEDs and the second LEDs are different.

96. The method of claim 93, wherein the respective pluralities of first and second LEDs are arranged as a package including at least one of a housing and the substrate, and wherein the method further comprises an act of:

- engaging the package mechanically and electrically with a conventional light socket.

97. The method of claim 93, wherein the at least one network signal is formatted using a DMX protocol, and wherein the act D1) includes an act of:

- independently controlling at least the first intensity of the first radiation and the second intensity of the second radiation based at least in part on the DMX protocol.

98. The method of claim 93, further comprising an act of: adjusting the overall perceivable color of the visible radiation via at least one user interface.

99. The method of claim 93, further comprising an act of: controlling the overall perceivable color of the visible radiation in response to at least one detectable condition.

100. The method of claim 93, wherein the respective pluralities of first and second LEDs are arranged as a package including at least one of a housing and the substrate, and wherein the method further comprises an act of:

- communicating at least one control signal to or from the package.

101. The method of claim 93, wherein the act D1) includes an act of:

- independently controlling at least the first intensity of the first radiation and the second intensity of the second radiation using a pulse width modulation (PWM) technique.

102. The method of claim 93, wherein the at least one network signal includes address information and lighting information for a plurality of illumination apparatus, and wherein the method further includes an act of:

- processing the at least one network signal based on at least the address information in the at least one network signal to recover the first lighting information.

103. An illumination method, comprising acts of:

- A) generating first radiation having a first spectrum from a first number of first light sources;
- B) generating second radiation having a second spectrum different than the first spectrum from a second number of second light sources, wherein the first number and the second number are different;
- C) mixing at least a portion of the first radiation and a portion of the second radiation to provide visible radiation having an overall perceivable color;
- D) receiving at least one addressed network signal including at least first lighting information relating to the overall perceivable color of the visible radiation; and
- E) independently controlling at least a first intensity of the first radiation and a second intensity of the second

radiation based at least in part on the first lighting information so as to controllably vary at least the overall perceivable color of the visible radiation.

104. An illumination apparatus, comprising:

- a plurality of first light sources adapted to generate first radiation having a first spectrum;
- a plurality of second light sources adapted to generate second radiation having a second spectrum different than the first spectrum; and

at least one controller coupled to the plurality of first light sources and the plurality of second light sources and configured to independently control at least a first intensity of the first radiation and a second intensity of the second radiation so as to controllably vary at least an overall perceivable color of visible radiation generated by the illumination apparatus,

wherein the at least one controller is configured to generate a first control signal to control all of the first light sources substantially identically, and a second control signal to control all of the second light sources substantially identically, and

wherein the at least one controller is configured as an addressable controller capable of receiving at least one network signal including at least first lighting information relating to the overall perceivable color of visible radiation generated by the illumination apparatus.

105. An illumination apparatus, comprising:

- a plurality of first LEDs adapted to generate first radiation having a first spectrum;
- a plurality of second LEDs adapted to generate second radiation having a second spectrum different than the first spectrum;

at least one addressable controller coupled to the plurality of first LEDs and the plurality of second LEDs, the at least one addressable controller configured to be associated with an alterable address, the at least one addressable controller further configured to independently control at least a first intensity of the first radiation and a second intensity of the second radiation so as to controllably vary an overall perceivable color of visible radiation generated by the illumination apparatus; and an address selection device configured to facilitate a selection of the alterable address associated with the at least one addressable controller.

106. An illumination apparatus, comprising:

- a first number of first light sources adapted to generate first radiation having a first spectrum; and
- a second number of second light sources adapted to generate second radiation having a second spectrum different than the first spectrum, wherein the first number and the second number are different; and

at least one controller coupled to the first number of first light sources and the second number of second light sources and configured to independently control at least a first intensity of the first radiation and a second intensity of the second radiation so as to controllably vary at least an overall perceivable color of visible radiation generated by the illumination apparatus,

wherein the at least one controller is configured as an addressable controller capable of receiving at least one network signal including at least first lighting information relating to the overall perceivable color of visible radiation generated by the illumination apparatus.