



US007232236B2

(12) **United States Patent**  
**Vitense et al.**

(10) **Patent No.:** **US 7,232,236 B2**  
(45) **Date of Patent:** **Jun. 19, 2007**

(54) **FLOOR MARKING APPARATUS AND SYSTEM, AND METHOD OF MARKING A FLOOR**

(75) Inventors: **Craig T. Vitense**, Mazomanie, WI (US); **Alexander P. Stoltz**, Madison, WI (US)

(73) Assignee: **Electronic Theatre Controls, Inc.**, Middleton, WI (US)

(\* ) Notice: Subject to any disclaimer, the term of this patent is extended or adjusted under 35 U.S.C. 154(b) by 190 days.

(21) Appl. No.: **11/031,226**

(22) Filed: **Jan. 6, 2005**

(65) **Prior Publication Data**

US 2006/0146520 A1 Jul. 6, 2006

(51) **Int. Cl.**  
**F21S 8/00** (2006.01)

(52) **U.S. Cl.** ..... **362/153; 362/812; 40/560; 116/209; 340/332; 340/691.1**

(58) **Field of Classification Search** ..... **362/153, 362/153.1, 259, 812; 40/550, 560, 565; 116/209; 182/18; 340/332, 691.1, 815.54, 815.55, 340/815.56, 815.57**

See application file for complete search history.

(56) **References Cited**

U.S. PATENT DOCUMENTS

1,065,845 A 6/1913 Sauvage

2,200,959 A	5/1940	Land
2,270,474 A	1/1942	Recher
4,141,056 A	2/1979	Neely
4,160,285 A	7/1979	Shibla
4,347,499 A	8/1982	Burkman, Sr. et al.
4,631,675 A	12/1986	Jacobsen et al.
5,343,374 A	8/1994	Gordin et al.
5,572,183 A	11/1996	Sweeney
6,000,810 A	12/1999	Nolan et al.
6,150,943 A *	11/2000	Lehman et al. .... 362/259
6,731,079 B2	5/2004	Andersen

\* cited by examiner

*Primary Examiner*—Stephen F. Husar

(74) *Attorney, Agent, or Firm*—Greer, Burns & Crain, Ltd.; Philip M. Kolehmainen

(57) **ABSTRACT**

A floor marking system includes a floor having a predetermined location intended for use of a predetermined character, the predetermined location being marked with impinging light. The floor marking system also includes a lighting unit having a light source for marking light onto the floor at a predetermined location. A patterning device is disposed between the light source and the floor, and is configured and arranged to mark at least one of a graphic pattern and a color onto the floor at the predetermined location with the impinging light. The at least one of the graphic pattern and the color marked on the floor by the lighting unit and the patterning device forms an indicator, and the indicator corresponds to the character of use of the floor at the predetermined location.

**21 Claims, 3 Drawing Sheets**

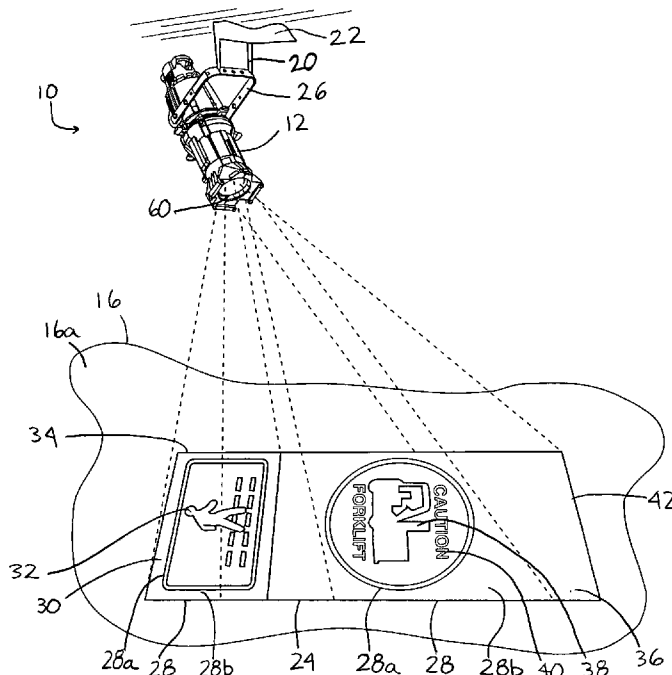

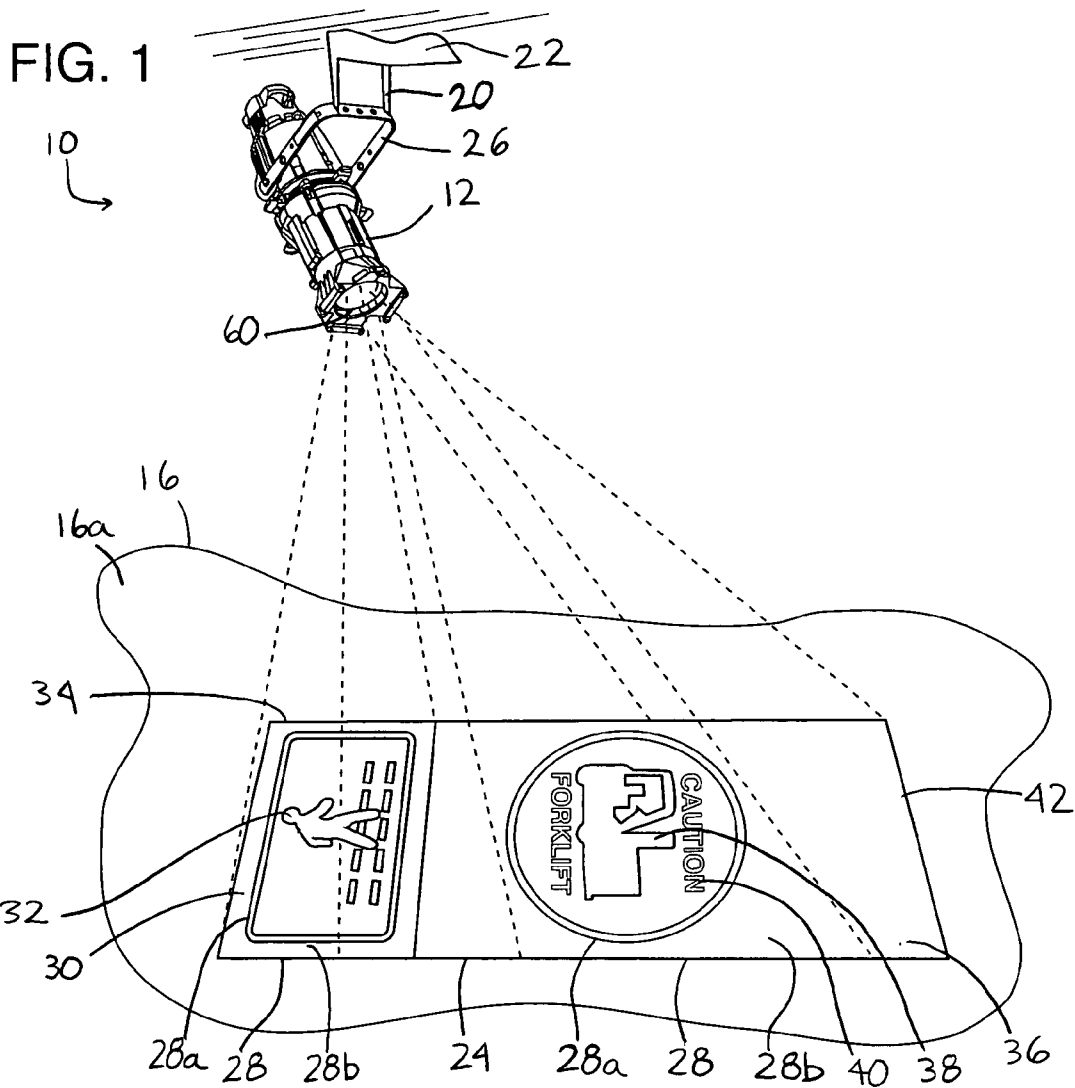
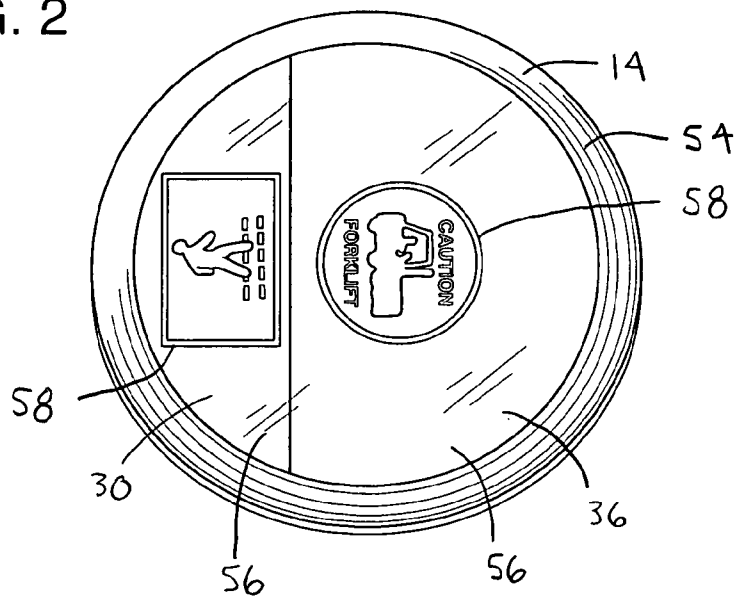

FIG. 2





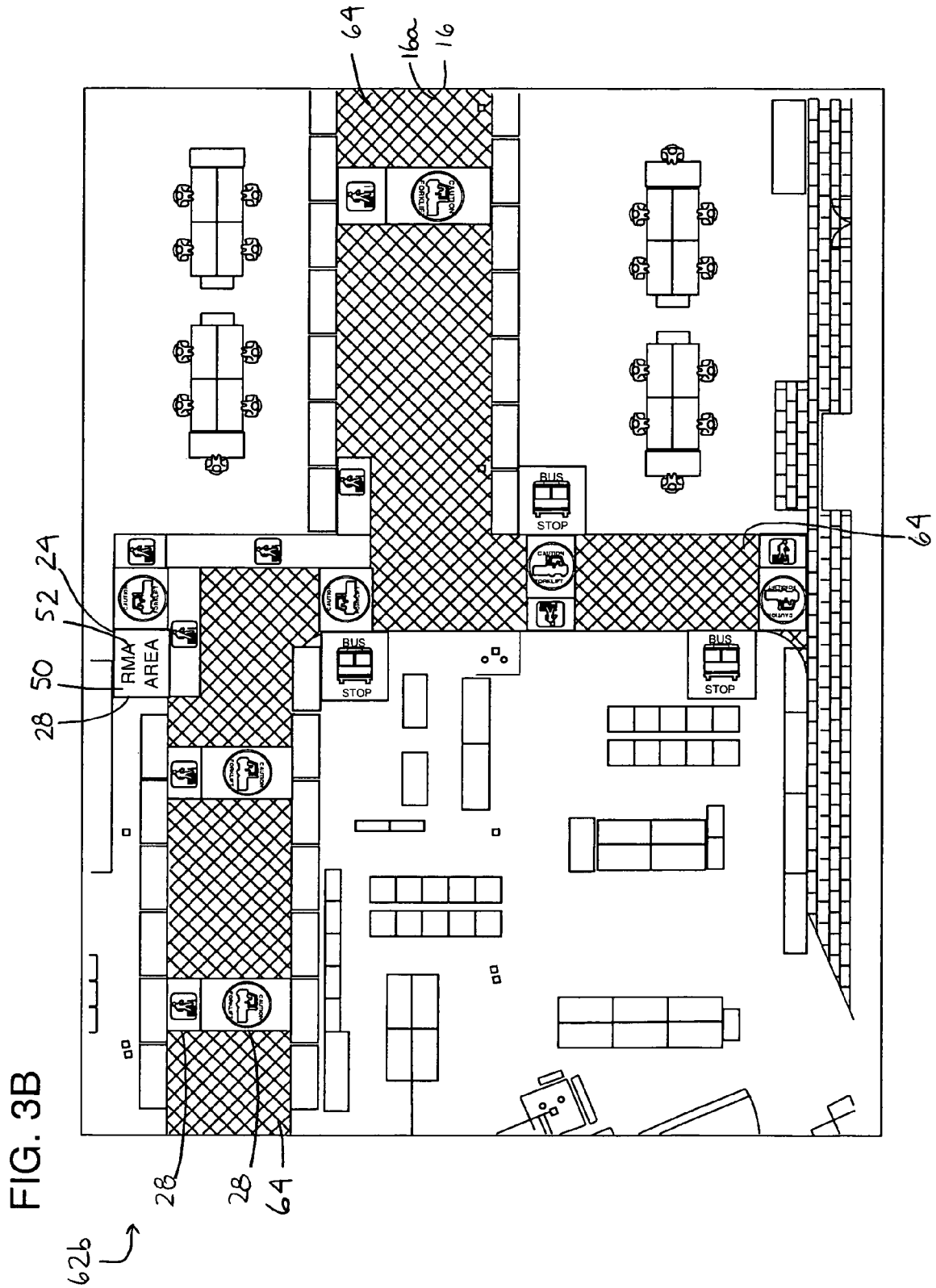

FIG. 3B

1

## FLOOR MARKING APPARATUS AND SYSTEM, AND METHOD OF MARKING A FLOOR

### FIELD OF THE INVENTION

The present invention relates to floor marking systems in general, and more specifically to an improved floor marking system for a factory and to a method of marking a floor.

### DESCRIPTION OF THE PRIOR ART

Under the Occupational Safety and Health Standards Act (OHSA), Federal law dictates that workplaces be marked with certain safety information. Particularly in industrial workplaces, current laws require the marking of permanent aisles and passageways. Further, it is advantageous to mark the floors with information regarding hazards and safety in the workplace, such as low clearances and the location of emergency exits. Floor markings can also increase efficiency in the workplace by designating locations for a specific character of use, and by generally adding to the organization of the workplace.

Floor marking systems are known in the art. It is conventional in factories and warehouses to mark the floor to show areas such as pedestrian walkways, fork lift lanes, and so forth. Usually this is done by attaching a colored marking material to the floor, such as adhesive-backed tape, or by painting on the floor. Such conventional floor marking systems experience several disadvantages in operation.

One disadvantage experienced by the conventional floor markings is that the markings wear out or fade. In the case of floor paint, the paint must be renewed periodically when fading occurs. Further, when adhesive-backed tape fails, such as by the adhesive failing to adhere to the floor or when the tape tears, new tape must be reapplied. The maintenance of paint and tape is both time consuming and labor intensive.

Another disadvantage experienced by the conventional floor markings is that when the factory or warehouse layout changes, the markings must be removed, such as by scraping off or lifting off the old markings, and new markings must be applied for the new layout. This process of removing and reapplying conventional floor markings is time consuming and labor intensive.

### SUMMARY OF THE INVENTION

A floor marking system in accordance with the present invention includes a floor having a predetermined location intended for use of a predetermined character, the predetermined location being marked with impinging light. The floor marking system also includes a lighting unit having a light source for marking light onto the floor at a predetermined location. A patterning device is disposed between the light source and the floor, and is configured and arranged to mark at least one of a graphic pattern and a color onto the floor at the predetermined location with the impinging light. The at least one of the graphic pattern and the color marked on the floor by the lighting unit and the patterning device forms an indicator, and the indicator corresponds to the character of use of the floor at the predetermined location.

Further in accordance with the invention, a floor includes a floor surface having a predetermined location intended for floor traffic of a predetermined character. The predetermined location is marked by impinging light containing a color and a graphic pattern corresponding to the character of the floor traffic.

2

Further in accordance with the invention, a floor includes a floor surface having a predetermined location intended for receiving and storing objects of a predetermined character. The predetermined location is marked by impinging light containing a color and a graphic pattern corresponding to the character of the objects to be received and stored.

A patterning device is provided for projecting an indicator onto a predetermined location on a floor using a light source, the predetermined location intended for use of a predetermined character, and includes a transparent, colored member configured for placement between the light source and the floor for marking the predetermined location with impinging, colored light. A pattern on the transparent member is used for marking the predetermined location with impinging light defining a graphic pattern. Further, the color and the graphic pattern correspond to the character of use of the floor at the predetermined location.

In accordance with another aspect of the invention, a method for marking a floor to indicate the designated use of the floor includes the steps of positioning a lighting unit having a light source for projecting a beam of light onto the floor at a predetermined location having a predetermined character of use, and placing an optical device between the light source and the floor. The optical device is configured and arranged to modify the beam of light to mark information onto the floor at the predetermined location with impinging light. A further step includes illuminating the floor with the information forming an indicator with the impinging light, where the information corresponds to the character of use of the floor at the predetermined location.

### BRIEF DESCRIPTION OF THE DRAWING

The present invention together with the above and other objects and advantages may best be understood from the following detailed description of the preferred embodiment of the invention illustrated in the drawings, wherein:

FIG. 1 is a perspective view of the floor marking apparatus of the present invention;

FIG. 2 is a front view of a patterning device for use in the floor marking apparatus of FIG. 1;

FIG. 3A is a schematic plan view of a factory floor using the floor marking system of the present invention and having a first layout; and

FIG. 3B is a schematic plan view of the factory floor of FIG. 3A rearranged to a different, second layout.

### DETAILED DESCRIPTION OF THE PREFERRED EMBODIMENT

Referring now to FIGS. 1 and 2, there is illustrated a floor marking apparatus in accordance with the present invention generally designated **10**, including a lighting unit **12**, a patterning device **14** and a floor **16**. The floor marking apparatus **10**, as shown and described, is constructed and arranged to project light onto the floor **16** of an industrial building, such as a factory or a warehouse, to indicate fork lift lanes, pedestrian lanes, and the like. It is contemplated that the floor marking apparatus **10** can be used in commercial or private settings, as well as outside of buildings.

The lighting unit **12** of the preferred embodiment is an ellipsoidal reflector spotlight having a light source (not shown) for projecting light. The light source in the lighting unit **12** is preferably an arc source, however it is contemplated that other lighting units using other light sources such as a tungsten filament lamp can be used. In the preferred embodiment, the lighting unit **12** is preferably removably

attached to a positioning point **20**, preferably on a ceiling **22** or other surface, such that the light emitted from the lighting unit **12** is projected to a predetermined location **24** on the floor **16**.

The predetermined location **24** is intended for use of a predetermined character. For example, the floor **16** has a floor surface **16a** that may be intended for floor traffic of a predetermined character, such as forklift traffic or pedestrian traffic. Further, the floor surface **16a** may be intended for receiving and storing objects, such as objects to be transported from one area of the factory to another location. Further, it is contemplated that the predetermined location **24** may be used for other uses, such as to keep clear of objects, for example near an emergency exit.

The floor surface **16a** receives impinging light emitted from the lighting unit **12** at the predetermined location. Depending on the lighting unit **12**, photometric data associated with the unit can be used to position the lighting unit on the positioning point **20** to project the beam of light at the predetermined location **24**. For example, using a particular lighting unit **12**, the distance from the lighting unit to the predetermined location **24**, the field diameter of the light projected, and the illumination at the predetermined location can be determined. In the preferred embodiment, a 36-degree lighting unit **12** is positioned about 27-feet from the predetermined location **24** on the floor **16**.

Further, the lighting unit **12** can simply be placed on the positioning point **20**, and if the light projected is not desirable, the characteristics of the lighting unit can be changed such as by interchanging lenses and lamps. Further still, the direction of the light beam is preferably adjustable by moving the lighting unit **12** relative to the positioning point **20**. Preferably, a mounting member or yoke **26** is disposed on the lighting unit **12** to attach the lighting unit to the positioning point **20**, and further, enables adjustment of the direction of projection of the lighting unit.

At the floor **16**, an indicator **28** is projected from the lighting unit **12**. The indicator **28** conveys information related to the character of use of the floor **16** at the predetermined location **24**, such as safety or utility information. Preferably, the indicator **28** conveys safety or utility information relevant to an industrial building, such as a factory or warehouse, at that predetermined location **24**. The indicator **28** is formed of at least a graphic pattern **28a** or a color **28b** which appears at the floor surface **16a**, and which corresponds to the character of use of the floor **16** at the predetermined location **24**. The indicator **28** being marked by impinging light onto the floor **16** preferably corresponds to the character of floor traffic, or the character of objects to be received and stored at the predetermined location **24**.

Examples of indicators **28** are shown in FIG. 1. In a first example, the indicator **28** may be a region **30** of the floor **16** colored green and a pattern **32** of a person walking. This indicates that the predetermined location **24** on which the indicator **28** is projected is a pedestrian walkway **34** and that it is safe to walk there.

In another example, the indicator **28** may be a region **36** colored orange, a symbol **38** of a fork lift, and a legend **40** stating "CAUTION FORKLIFT", to indicate that the predetermined location **24** on which the indicator is projected is a fork lift lane **42**, and that a person should proceed with caution.

Examples of other indicators are shown in FIGS. 3A and 3B. For example, the indicator **28** may be a region **44** colored blue, a symbol **46** of a bus, and a legend **48** stating "BUS STOP", to indicate that a fork lift or vehicle stops at the predetermined location to load or unload goods.

In still a further example, the indicator **28** may be a region **50** colored red **50** and a legend **52** stating "RMA AREA". In this particular example, the indicator **28** may indicate that goods not passing quality control standards should be placed there.

It should be understood that the invention is not limited to these examples, but that the indicator **28** can be used to convey any sort of information that is relevant to the predetermined location **24**. For example, in a retail space, the indicator may be a legend stating "LINE FORMS HERE", indicating that the predetermined location is where people should line up to make their purchases.

Referring again to FIGS. 1 and 2, to project an indicator **28** on to the predetermined location **24**, an optical device, preferably a patterning device **14**, is disposed between the light source (not shown) and the floor. The patterning device **14** is preferably a gobo **54**. A gobo **54** has a transparent body **56**, preferably a dichroic glass filter, having a pattern **58** etched, removed, blocked or otherwise defined, which is placed into the lighting unit **12**. Other materials such as metal or colored glass may be used. Alternatively, the patterning device **14** can be positioned adjacent the exterior of the light source. A plastic material may be used if the patterning device is external. The patterning device **14** is configured and arranged to modify the beam of light from the lighting unit **12** to mark information onto the floor **16** at the predetermined location **24** with the impinging light.

In the preferred embodiment, the gobo **54** is a sheet **56** of glass, preferably a dichroic glass filter, having a color or capable of transmitting a color corresponding to the projected color **28b**. The member **56** is preferably etched to define the pattern **58** corresponding to the projected graphic pattern **28a**. At the point of etching, the otherwise colored, transparent member **56** is preferably colorless. Thus, in the gobo **54** of FIG. 2, the member **56** has, or transmits, the colors green **30** and orange **36** and has two etched patterns. This configuration results in the projected indicators **28** including green **30** and orange **36** regions with "white" or non colored graphic portions **28a** corresponding to the patterns **58** etched, as is known in the art.

In a similar configuration, the pattern **58** on the gobo **54** may be blocked or otherwise made opaque, resulting in the indicator **28** appearing as projected light in some portions, and appearing as a graphic **28a** of "blocked" light in other portions. Further, the indicator **28** projected by the patterning device **14** may be a color **28b** without a graphic pattern **28a**, or may be a pattern without a color. Additionally, other types of patterning devices **14** may be used, such as a sheet of metal with portions removed, as is known in the art.

Preferably, the patterning device **14** is placed inside the lighting unit **12**, and with the appropriate focusing, the indicator **28** is projected onto the floor **16** at the predetermined location **24**. Depending on the type of lighting unit **12**, a receiving slot **60** may be disposed on the lighting unit **12** to receive the patterning device **14**.

The direction of light projection of the lighting unit **12** is preferably adjustable at the positioning point **20**. In the event that the layout of the factory or the warehouse changes, the lighting unit **12** can be rotated, moved, or otherwise adjusted at the positioning point **20**. However, if the layout of the factory or the warehouse changes to the extent that the location of the positioning point **20** does not enable the lighting unit **12** to project light on the new predetermined location **24**, the lighting unit can be attached to a new positioning point **20**.

In typical installation, a plurality of lighting units **12** and patterning devices **14** are used to project indicators **28** onto

5

a number of portions of a floor. Referring now to FIG. 3A, a first exemplary factory layout 62a has two aisles 64, which intersect generally centrally on one side of the layout. Projected onto the aisles 64 and the factory floor 16 at predetermined locations 24 are indicators 28 preferably having colors 28b and/or graphic patterns 28a. The indicators 28 having the symbol of a fork lift 38 indicate fork lift lanes 42, the indicators having the symbol of a person walking 32 indicate pedestrian corridors, and the indicators having the symbol of a bus 46 indicate where goods should be placed for pickup. Each indicator 28 has an associated lighting unit 12 that is projecting the indicator onto the floor 16.

The indicators 28 having the symbol 32 of a person walking are located at spaced apart regions along pedestrian aisles defined between reference lines 66 and 68. In accordance with the invention, lighting units 12 may be used to light these aisles along their full lengths, thus providing a visual guide along the entire pathway. In the aisle regions between the symbols 32, the lighting units may have patterning devices with colors 28b without patterns 28a. In this exemplary case, the pedestrian aisles are colored green throughout, with spaced apart regions having the symbols 28a.

The present invention makes it easy to alter the floor marking arrangement to accommodate changes in the factory floor layout. Referring now to FIG. 3B, the layout of the factory 62b has been changed with respect to FIG. 3A. In FIG. 3B, there are three aisles 64 which intersect at different points, and the "RMA AREA" indicator 52 is marked on the floor 16. The location of the indicators 28 is changed to suit the new layout 62b, and the associated lighting units 12 have been either reaimed or moved. This is much faster and easier than removing and reapplying conventional floor marking tapes or paints.

The present invention can be embodied in the form of a kit that includes one or a number of lighting units 12 together with a selection of a plurality of different patterning devices 14. The patterning devices 14 in the kit can contain information in the form or color and/or graphics corresponding to different uses to which portions of a floor may be put. The user of the kit mounts the lighting unit or units 12 in desired locations and selects the appropriate patterning device or devices to mark a floor to suit a desired layout.

While the present invention has been described with reference to the details of the embodiment of the invention shown in the drawing, these details are not intended to limit the scope of the invention as claimed in the appended claims.

What is claimed is:

1. A floor marking system for a factory or warehouse, comprising:
  - a floor having a predetermined location intended for use of a predetermined character, said predetermined location being marked with impinging light;
  - a lighting unit having a light source for marking light onto said floor at said predetermined location; and
  - a patterning device disposed between said light source and said floor, wherein said patterning device is configured and arranged to mark at least one of a graphic pattern and a color onto said floor at said predetermined location with said impinging light;
 wherein said at least one of a graphic pattern and a color marked on said floor by said lighting unit and said patterning device forms an indicator; and

6

wherein said indicator corresponds to the normal, non-emergency character of use of said floor at said predetermined location;

wherein the floor marking system is selectively activated by a user to indicate the normal, non-emergency use of the floor.

2. The floor marking system as defined in claim 1, wherein said lighting unit comprises multiple lighting units and said patterning device comprises multiple interchangeable patterning devices for marking multiple indicators on said floor.

3. The floor marking system as defined in claim 2, wherein said predetermined location comprises multiple predetermined locations, wherein said multiple indicators are marked at said multiple predetermined locations.

4. The floor marking system as defined in claim 1, wherein said indicator conveys information relevant to safety or utility in the factory or warehouse at said predetermined location.

5. The floor marking system as defined in claim 1, wherein said lighting unit is removably attached to a positioning point, and the direction of light projection of said lighting unit is adjustable at said positioning point.

6. A floor marking kit for marking a floor having a predetermined location intended for use of a predetermined character, comprising:

a lighting unit having a light source for marking light onto the floor at the predetermined location; and

a plurality of interchangeable patterning devices configured to be disposed adjacent said light source, wherein said patterning devices are configured and arranged to mark at least one of a graphic pattern and a color onto the floor at the predetermined location with impinging light;

wherein said at least one of a graphic pattern and a color marked on the floor by said lighting unit and said patterning device forms an indicator; and

wherein said indicator corresponds to the character of use of the floor at the predetermined location;

wherein said plurality of patterning devices are interchangeable in response to a change in the character of use of the floor at the predetermined location.

7. The floor marking kit as defined in claim 6, wherein said indicator conveys information relevant to safety or utility in a factory or warehouse at said predetermined location.

8. The floor marking kit as defined in claim 7, wherein said indicator comprises one of "CAUTION FORKLIFT", "BUS STOP", "RMA AREA", and a symbol of a pedestrian.

9. The floor marking kit as defined in claim 6, wherein said lighting unit is configured to removably attach to a positioning point, and is configured to adjust the direction of light projection at said positioning point.

10. The floor marking kit as defined in claim 6, wherein said patterning device comprises a gobo for attachment to said lighting unit.

11. A floor comprising:

a floor surface;

said floor surface having a first predetermined location intended for floor traffic of a first predetermined character;

said first predetermined location being marked by impinging light forming a first indicator containing at least one of a first color and a first graphic pattern corresponding to said character of said first floor traffic;

7

said floor surface having a second predetermined location intended for floor traffic of a second predetermined character different from said first predetermined character;

said second predetermined location being marked by impinging light forming a second indicator containing at least one of a second color and a second graphic pattern corresponding to said character of said second floor traffic, wherein said second indicator is different from said first indicator;

wherein said first and second indicators indicate normal, non-emergency character of use of the floor.

12. The floor of claim 11 wherein said first predetermined location is intended for one of forklift traffic and pedestrian traffic.

13. A floor comprising:  
a floor surface;

said floor surface having a predetermined location intended for receiving and storing objects of a predetermined character;

said predetermined location being marked by impinging light containing a color and a graphic pattern corresponding to said character of said objects to be received and stored;

wherein said predetermined location is intended for objects to be temporarily stored before being transported elsewhere.

14. A patterning device for projecting an indicator onto a predetermined location on a factory or warehouse floor using a light source, the predetermined location intended for use of a predetermined character, said patterning device comprising:

a transparent, colored member configured for placement between the light source and the floor for marking the predetermined location with impinging, colored light;

a pattern on said transparent member for marking the predetermined location with impinging light defining a graphic pattern forming the indicator;

8

wherein said color and said graphic pattern corresponds to the normal, non-emergency character of use of the factory or warehouse floor at the predetermined location.

15. The patterning device of claim 14 wherein said graphic pattern comprises one of "CAUTION FORKLIFT", "BUS STOP", "RMA AREA", and a symbol of a pedestrian.

16. The patterning device of claim 14 wherein said transparent, colored member is constructed of one of glass and plastic.

17. A method for marking a floor to indicate designated use of the floor, comprising the steps of:

positioning a lighting unit having a light source for projecting a beam of light onto the floor at a predetermined location having a predetermined character of use;

placing an optical device between said light source and said floor, wherein said optical device is configured and arranged to modify said beam of light to mark information onto the floor at said predetermined location with impinging light; and

selectively illuminating said floor with said information forming an indicator with said impinging light; wherein said information corresponds to the normal, non-emergency character of use of the floor at said predetermined location.

18. The method as defined claim 17, further comprising the step of arranging the patterning device on said lighting unit.

19. The method as defined in claim 17, further comprising the step of changing the location of the lighting unit when said predetermined location changes.

20. The method as defined in claim 17 wherein said optical device comprises a patterning device.

21. The method as defined in claim 17 wherein said indicator comprises at least one of a graphic pattern and a color.

\* \* \* \* \*