



US006955452B2

(12) **United States Patent**  
**Li**

(10) **Patent No.:** **US 6,955,452 B2**  
(45) **Date of Patent:** **\*Oct. 18, 2005**

- (54) **ILLUMINATION SYSTEM USING FILAMENT LAMPS**
- (75) Inventor: **Kenneth K. Li**, Arcadia, CA (US)
- (73) Assignee: **Wavien, Inc.**, Santa Clarita, CA (US)
- (\* ) Notice: Subject to any disclaimer, the term of this patent is extended or adjusted under 35 U.S.C. 154(b) by 0 days.  
  
This patent is subject to a terminal disclaimer.

4,897,771 A	1/1990	Parker	
4,956,759 A *	9/1990	Goldenberg et al. ....	362/297
4,957,759 A	9/1990	Swartzel et al.	
5,191,393 A	3/1993	Hignette et al.	
5,414,600 A *	5/1995	Strobl et al. ....	362/551
5,430,634 A	7/1995	Baker et al.	
5,707,131 A	1/1998	Li	
5,777,809 A	7/1998	Yamamoto et al.	
5,803,579 A *	9/1998	Turnbull et al. ....	362/516
5,873,646 A *	2/1999	Fjaestad et al. ....	362/92
5,900,973 A	5/1999	Marcellin-Dibon et al.	
5,986,792 A	11/1999	Rizkin et al.	
6,227,682 B1 *	5/2001	Li	362/302
6,356,700 B1	3/2002	Strobl	
6,616,304 B2 *	9/2003	Li	362/302
6,619,820 B2 *	9/2003	Li	362/302

(21) Appl. No.: **10/078,256**

(22) Filed: **Feb. 20, 2002**

(65) **Prior Publication Data**

US 2002/0141191 A1 Oct. 3, 2002

**Related U.S. Application Data**

(60) Provisional application No. 60/269,888, filed on Feb. 21, 2001.

(51) **Int. Cl.**<sup>7</sup> ..... **F21V 7/00**

(52) **U.S. Cl.** ..... **362/297; 362/302; 362/346; 362/560**

(58) **Field of Search** ..... **362/296, 297, 362/298, 341, 346, 551, 560, 302**

(56) **References Cited**

**U.S. PATENT DOCUMENTS**

3,772,506 A *	11/1973	Junginger	362/572
3,986,767 A	10/1976	Rexer et al.	
4,149,227 A *	4/1979	Dorman	362/297
4,357,075 A	11/1982	Hunter	
4,473,295 A	9/1984	Doyle	
4,519,266 A	5/1985	Reinecke	
4,608,622 A	8/1986	Gonser	
4,634,276 A	1/1987	Sharpe	
4,757,431 A	7/1988	Cross et al.	
RE32,912 E	4/1989	Doyle	

**FOREIGN PATENT DOCUMENTS**

EP	0401351	9/1993
WO	WO 0102774 A1	1/2001
WO	WO 0173487 A2	10/2001

\* cited by examiner

*Primary Examiner*—Sandra O’Shea

*Assistant Examiner*—Sharon Payne

(74) *Attorney, Agent, or Firm*—Fulbright & Jaworski L.L.P.

(57) **ABSTRACT**

An illumination system using filament lamps including a filament lamp, a reflector having a first and second focal points, the filament lamp disposed proximate to the first focal point of the reflector to emit rays of electromagnetic radiation that reflect from the reflector and converge substantially at the second focal point, wherein a portion of the electromagnetic radiation emitted by the filament lamp impinges directly on the reflector and a portion of the electromagnetic radiation does not impinge directly on the reflector and wherein the system further includes an additional reflector constructed and arranged to reflect at least part of the portion of the electromagnetic radiation that does not impinge directly on the reflector toward the reflector through the first focal point of the reflector.

**37 Claims, 9 Drawing Sheets**

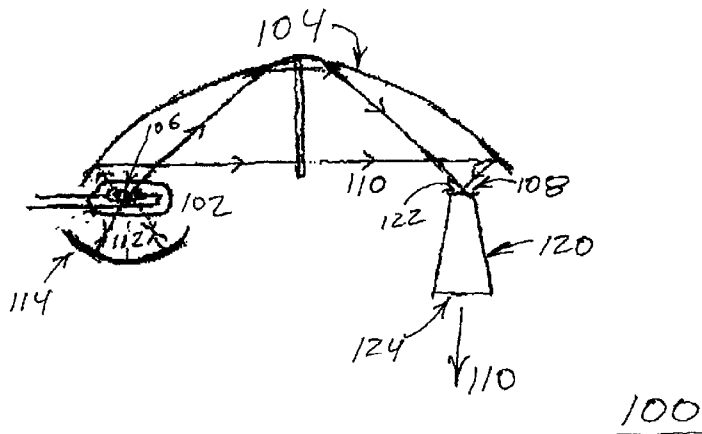



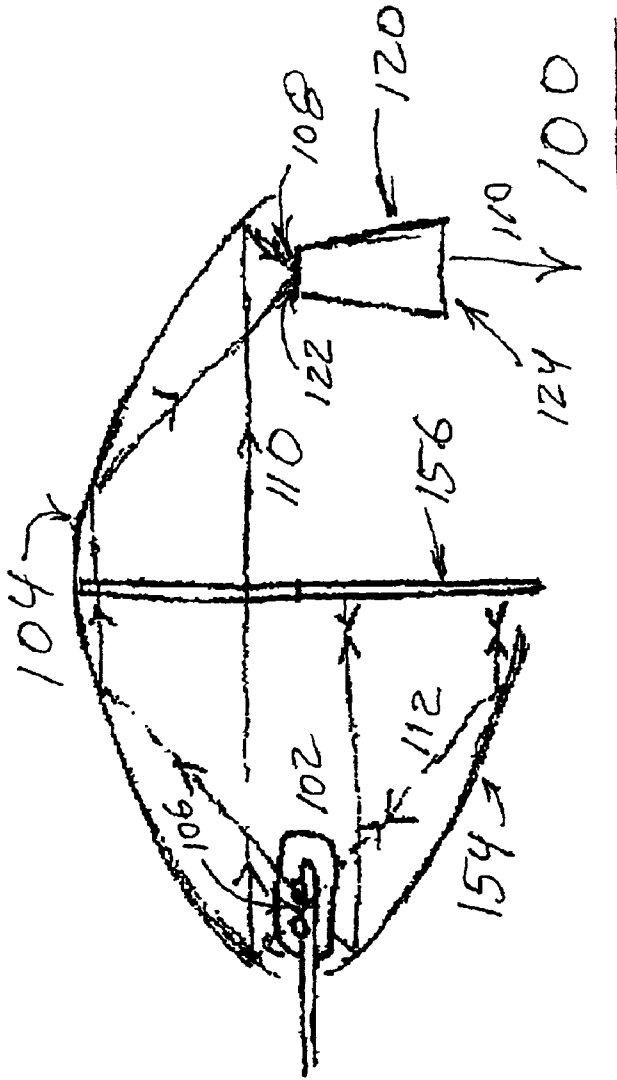
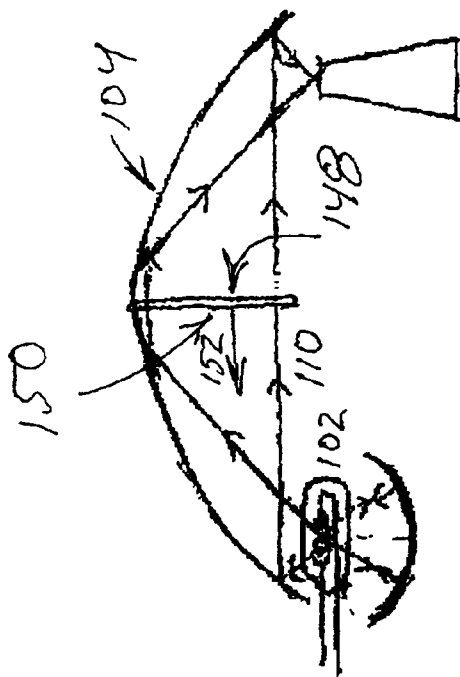

Figure 2



100

Figure 3

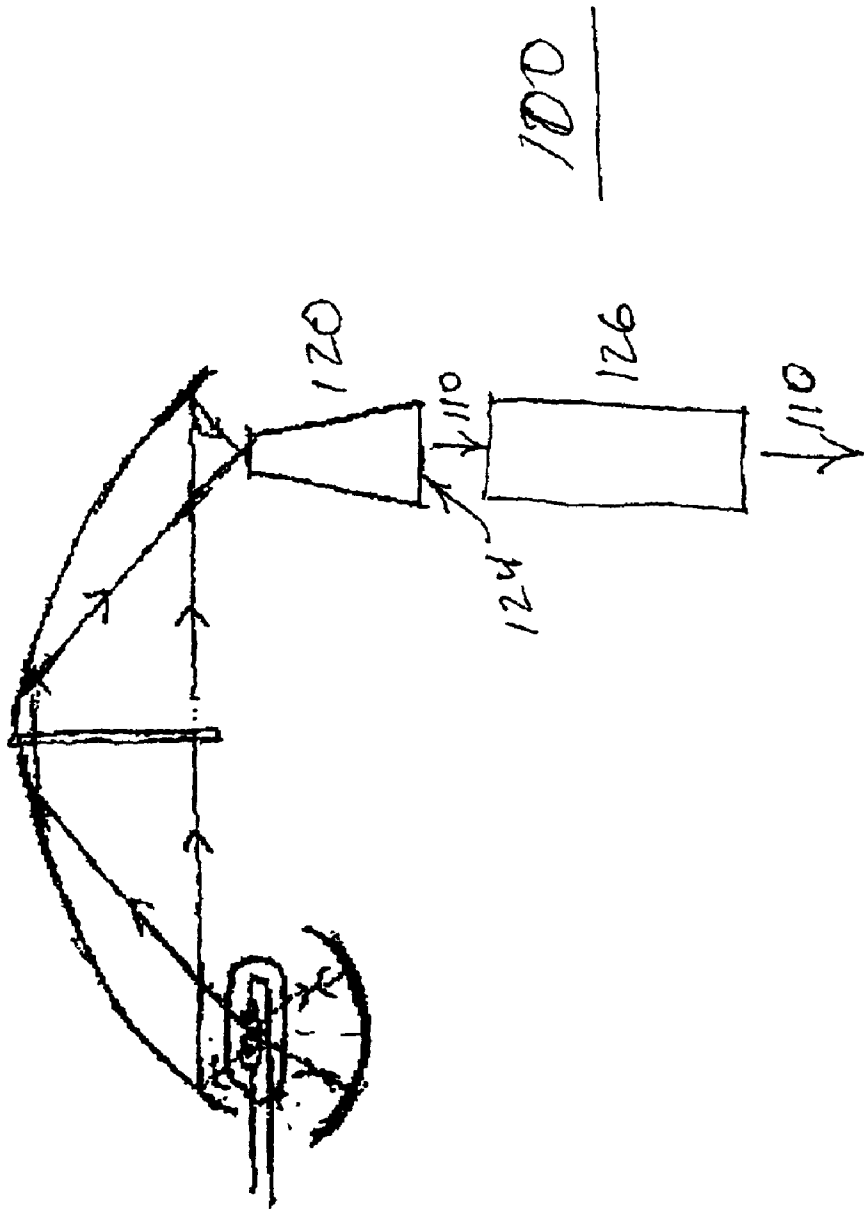

Figure 4 128

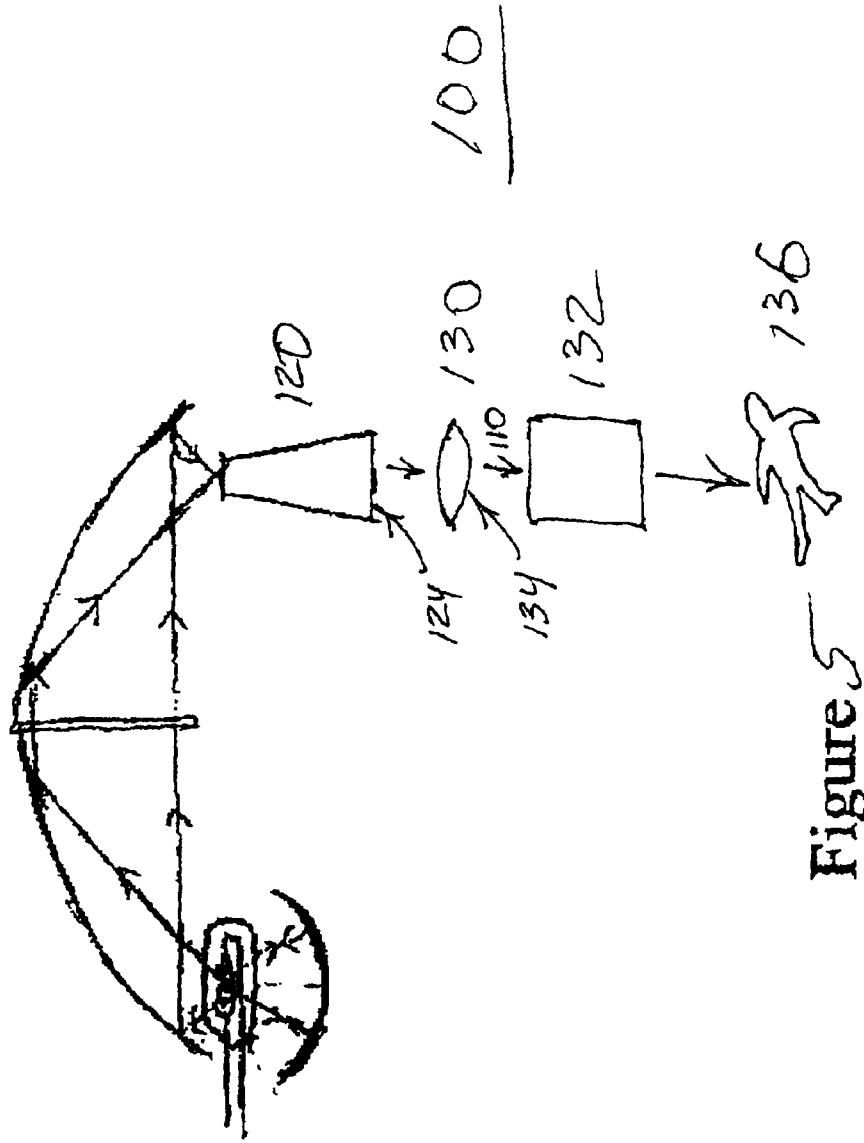

Figure 5

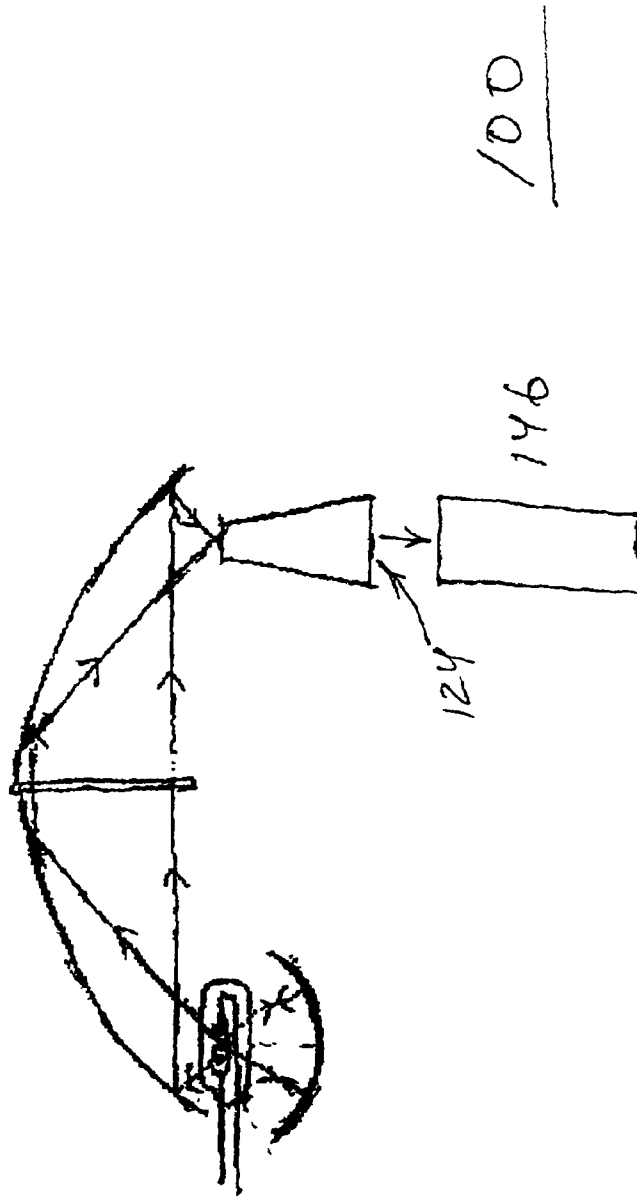

Figure 6

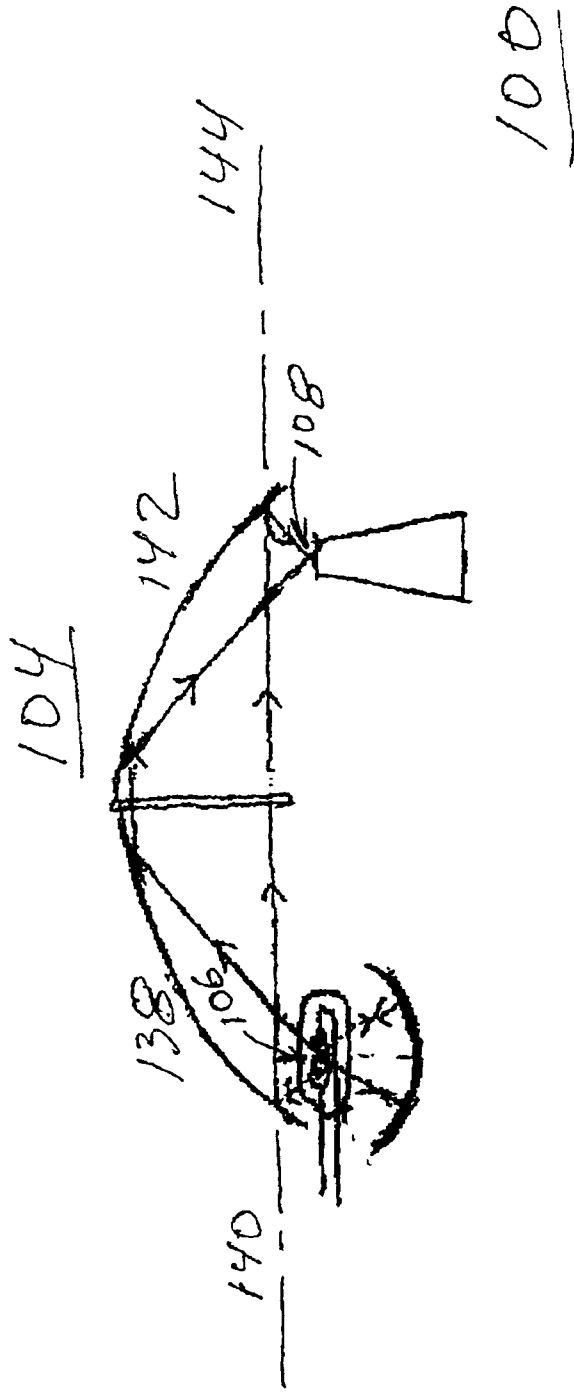
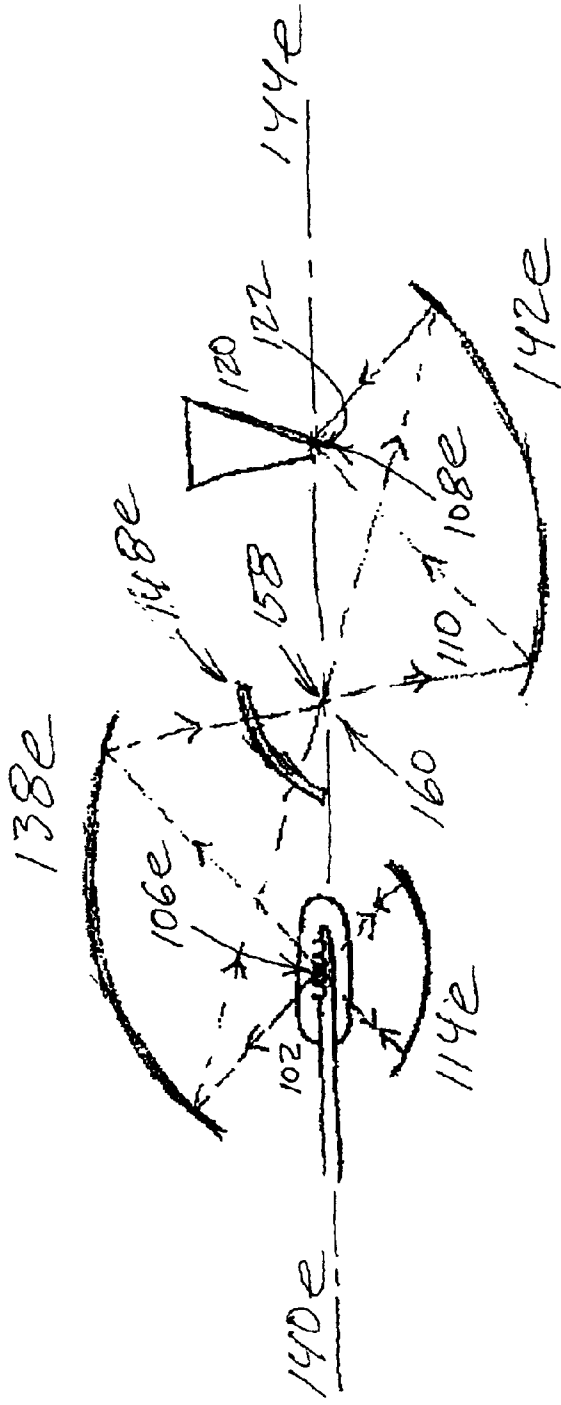

Figure 7



100e

Figure 8

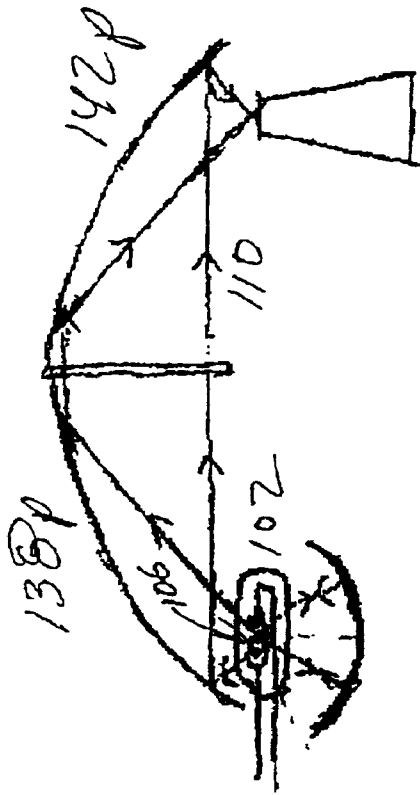

Figure 9

## ILLUMINATION SYSTEM USING FILAMENT LAMPS

### CROSS-REFERENCE TO RELATED APPLICATIONS

This application claims priority to Provisional Application Ser. No. 60/269,888, filed Feb. 21, 2001, the disclosure of which is incorporated by reference.

### BACKGROUND OF THE INVENTION

#### 1. Field of the Invention

The invention relates to illumination systems using filament lamps.

#### 2. Description of the Related Art

On-axis reflector systems, such as e.g. elliptical and parabolic reflector systems, are often used in e.g. fiber optic illuminators, projection engines for large screen displays, and projection monitors. Such on-axis reflector systems may be used to couple electromagnetic radiation from a source into small targets. On-axis reflector systems, however, may magnify electromagnetic radiation emitted by the source in different amounts at different angles. The differences in magnification are exacerbated by the size of the light source. An ideal source for such an on-axis system is thus a point source.

Arc lamps are often used as sources of electro-magnetic radiation in such systems rather than, e.g. filament lamps, because they are small enough to approximate a point source. Arc lamps are smaller than, e.g. filament lamps, because a, e.g. tungsten filament inside the filament lamp is generally longer than an arc of a comparable short arc lamp. If filament lamps were used in an on-axis reflector system, the image of the filament would be magnified differently for different angles of emitted radiation, resulting in a large fuzzy spot. Filament lamps are thus very inefficient for coupling light into small targets. Filament lamps, however, are generally less expensive, and last longer, than arc lamps. Filament lamps are thus generally used in on-axis reflector systems only if efficiency is not an issue. In applications where efficiency is not an issue a filament lamp such as, e.g. a large wattage lamp may be used.

There thus exists a need for a coupling system that can couple electromagnetic radiation from a filament lamp at high efficiency into a small target.

### SUMMARY OF THE INVENTION

In one aspect, the invention consists of an illumination system using filament lamps including a filament lamp, a reflector having a first and second focal points, the filament lamp disposed proximate to the first focal point of the reflector to emit rays of electromagnetic radiation that reflect from the reflector and converge substantially at the second focal point, wherein a portion of the electromagnetic radiation emitted by the filament lamp impinges directly on the reflector and a portion of the electromagnetic radiation does not impinge directly on the reflector and wherein the system further comprises an additional reflector constructed and arranged to reflect at least part of the portion of the electromagnetic radiation that does not impinge directly on the reflector toward the reflector through the first focal point of the reflector.

In another aspect, the invention consists of a method of illumination including steps of positioning a filament lamp at a first focal point of a reflector, producing rays of radiation by the filament lamp, reflecting a portion of the rays of

radiation by the reflector toward a second focal point of the second reflector, converging the rays of radiation at the second focal point of the reflector, reflecting at least part of a portion of the rays of radiation that do not impinge directly on the reflector toward the reflector through the first focal point of the reflector, positioning an output light pipe having an input surface and an output surface so the input surface is substantially proximate to the second focal point, collecting the rays of radiation at the input surface, passing the rays of radiation through the output light pipe, and outputting rays of radiation from the output surface of the output light pipe.

### BRIEF DESCRIPTION OF THE SEVERAL VIEWS OF THE DRAWINGS

FIG. 1 is a schematic diagram of an illumination system according to one embodiment of the invention;

FIG. 2 is a schematic diagram of an illumination system according to an alternative embodiment of the invention;

FIG. 3 is a schematic diagram of an illumination system according to a third embodiment of the invention;

FIG. 4 is a schematic diagram of an illumination system according to a fourth embodiment of the invention;

FIG. 5 is a schematic diagram of an illumination system according to a fifth embodiment of the invention;

FIG. 6 is a schematic diagram of an illumination system according to a sixth embodiment of the invention;

FIG. 7 is a schematic diagram of an illumination system according to a seventh embodiment of the invention;

FIG. 8 is a schematic diagram of an illumination system according to an eighth embodiment of the invention; and

FIG. 9 is a schematic diagram of an illumination system according to a ninth embodiment of the invention.

### DETAILED DESCRIPTIONS OF THE PREFERRED EMBODIMENTS

In a first embodiment of the illumination system **100** using filament lamps, shown in FIG. 1, a filament lamp **102** may be disposed proximate to a first focal point **106** of a reflector **104** having a first and second focal points **106**, **108**. Filament lamp **102** may be, e.g. a tungsten filament lamp. Filament lamp **102** emits rays of electromagnetic radiation **110**. Some of rays of electromagnetic radiation **110** are reflected by reflector **104** and converge substantially at second focal point **108**.

Although some of rays of electromagnetic radiation **110** emitted by filament lamp impinge directly on reflector **104**, a portion of electromagnetic radiation **112** does not impinge directly on reflector **104**. Illumination system **100** further includes an additional reflector **114** constructed and arranged to reflect at least part of the portion of electromagnetic radiation **112** that does not impinge directly on reflector **104** toward reflector **104** through first focal point **106**. Since a filament of filament lamp **102** already occupies first focal point **106**, however, the filament of filament lamp **102** substantially blocks electromagnetic radiation **112**. The filament of filament lamp **102** will thus absorb some of electromagnetic radiation **112**. The portion of electromagnetic radiation **112** that is absorbed by the filament of filament lamp **102** may heat the filament of filament lamp **102**, raising its temperature. A higher temperature results in an increased light output, which may be on the order of 30%.

Additional reflector **114** may be, e.g. a spherical retro-reflector disposed on a side of filament lamp **102** opposite

reflector **104** to reflect electromagnetic radiation **112** emitted from filament lamp **102** toward reflector **104** through first focal point **106**. In an alternative embodiment, shown in FIG. 2, additional reflector **114** may be a combination of a parabolic reflector **154** and a planar mirror **156**. In a further alternative embodiment, a full circular parabolic reflector could be used.

In one embodiment, reflector **104** has a coating **116** that reflects substantially only a pre-specified portion **118** of a spectrum of electromagnetic radiation **110**. Pre-specified portion **118** may be, e.g. visible light radiation, ultraviolet (UV) radiation, infrared (IR) radiation, a pre-specified band of wavelengths of radiation, or a specific color of radiation.

In a third embodiment, shown in FIG. 3, illumination system **100** includes a filter **148** placed substantially in a path of rays of electromagnetic radiation **110**. Filter **148** has a coating **150** that reflects substantially only a pre-specified portion **152** of a spectrum of electromagnetic radiation **110**. In an alternative embodiment, coating **150** transmits substantially only a pre-specified portion **152** of a spectrum of electromagnetic radiation **110**. In either embodiment, pre-specified portion **152** may be, e.g. visible light radiation, ultraviolet radiation, infrared radiation, a pre-specified band of wavelengths of radiation, or a specific color of radiation.

In a preferred embodiment, filter **148** reflects ultraviolet radiation and infrared radiation back to first focal point **106**, while transmitting visible radiation toward second focal point **108**. This would be the case if, e.g. visible light was to be launched into an output device, but not ultraviolet radiation or infrared radiation. The infrared and ultraviolet radiation reflected by filter **148** can thus be refocused onto the filament of filament lamp **102**, heating the filament further to produce more light. As a result, more of the infrared and ultraviolet radiation would be trapped inside the reflector **104** and used for heating the filament of the filament lamp **102**, thus increasing the efficiency of the system **100**. The ultraviolet radiation and infrared radiation which would otherwise be wasted would thus be re-used. In a further alternative embodiment, one half of filter **148** could be a reflector and the other half a filter coated with a coating such as, e.g. coating **150**.

In a preferred embodiment, illumination system **100** includes an output light pipe **120** having an input surface **122** and an output surface **124**. Input surface **122** may be located proximate to second focal point **108** to collect substantially all of radiation **110**. Radiation **110** passes through output light pipe **120** and may be transmitted substantially by output surface **124**. Output light pipe **120** may be composed of, e.g. a material such as quartz, glass, plastic, or acrylic. Output light pipe **120** may be, e.g. a homogenizer, a tapered light pipe, or a straight light pipe. Output light pipe **120** may have, e.g. a cross-section such as a rectangle, a circle, a triangle, a trapezoid, a rhombus, a pentagon, a hexagon, or an octagon.

In a fourth embodiment, shown in FIG. 4, illumination system **100** may include further a fiber optic **126**, which may be illuminated substantially by radiation **110** transmitted at output surface **124** of output light pipe **120**, after which fiber optic **126** releases collected radiation **110** to provide for illumination at a desired location **128**.

In a fifth embodiment, shown in FIG. 5, illumination system **100** may include further a condenser lens **130** disposed substantially proximate to output surface **124** of output light pipe **120**. An image projection system **132** disposed substantially proximate to an output side **134** of condenser lens **130** releases radiation **110** collected and condensed by condenser lens **130** to display an image **136**.

In an sixth embodiment, shown in FIG. 6, illumination system **100** includes a waveguide **146** disposed substantially proximate to output surface **124**. Waveguide **146** may be, e.g. a single core optic fiber, a fiber bundle, a fused fiber bundle, a polygonal rod, or a hollow reflective light pipe. Waveguide **146** may further be, e.g. a circular waveguide, a polygonal waveguide, a tapered waveguide, or a combination thereof. Waveguide **146** may be composed of, e.g. a material such as quartz, glass, plastic, or acrylic.

In a seventh embodiment, shown in FIG. 7, reflector **104** of illumination system **100** comprises a first reflector **138** having a first optical axis **140** and a second reflector **142** having a second optical axis **144**. Second reflector **142** may be placed substantially symmetrically to first reflector **138** such that first and second optical axes **140**, **144** are substantially collinear. In this embodiment first focal point **106** may be a focal point of first reflector **138** and second focal point **108** may be a focal point of second reflector **142**.

In one embodiment, first and second reflectors **138**, **142** may each be, e.g. at least a portion of a substantially toric surface of revolution. In another embodiment, first and second reflectors **138**, **142** may each be, e.g. at least a portion of a substantially spheroid surface of revolution.

In an alternative embodiment, first reflector **138** shown in FIG. 7 comprises at least a portion of a substantially ellipsoid surface of revolution, while second reflector **142** comprises at least a portion of a substantially hyperboloid surface of revolution. In a further alternative embodiment, first reflector **138** comprises at least a portion of a substantially hyperboloid surface of revolution, while second reflector **142** comprises at least a portion of a substantially ellipsoid surface of revolution. The advantages of these variations would be shown in certain systems where other factors might require that the shapes are different, or the lamp envelope needs to be compensated, or the target may be larger such that 1:1 imaging is not necessary.

In an eighth embodiment, shown in FIG. 8, first and second reflectors **138e**, **142e** may each be, e.g. at least a portion of a substantially ellipsoid surface of revolution. FIG. 8 shows an embodiment of illumination system **100e** using two semi-circular elliptical mirrors **138e** and **142e** with substantially co-linear optical axes **140e**, **144e**.

The filament of filament lamp **102** may be placed at the focus **106e** of elliptical reflector **138e**. A spherical reflector **114e** provides retro-reflection. A spherical filter **148e** may be placed such that a center of curvature **158** of filter **148e** coincides with a common focal point **160** of the two elliptical reflectors **138e**, **142e**. Infrared and ultraviolet radiation incident onto the filter **148e** will be reflected back into itself along the same path back into the filament of filament lamp **102**.

In one embodiment, elliptical reflectors **138e**, **142e** have substantially the same shape. In other embodiments, elliptical reflectors **138e**, **142e** might, e.g. have a different ellipticity such that the projected image may be close to 1:1.

In a further embodiment, input surface **122** of output light pipe **120** may be placed at second focus **108e** of second elliptical reflector **142e** for collecting and transforming a numerical aperture (NA) of electromagnetic radiation **110** into, e.g. a lower NA.

In an ninth embodiment, shown in FIG. 9, first and second reflectors **138p**, **142p** may each be, e.g. at least a portion of a substantially paraboloid surface of revolution. Rays of radiation **110** collected by parabolic reflector **138p** may be collimated into parabolic reflector **142p**. The parabolic reflector **142p** may be placed substantially symmetrically

5

opposite parabolic reflector **138p**, thus producing an image of the filament of filament lamp **102** at first focal point **106** of parabolic reflector **138p** with a substantially unit magnification for all angles of light and preserving the brightness of the filament.

In a tenth embodiment, a method of illumination comprises the steps of positioning a filament lamp **102** at a first focal point **106** of a reflector **104**, producing rays of radiation **110** by filament lamp **102**, reflecting a portion of rays of radiation **110** by reflector **104** toward a second focal point **108** of reflector **104**, converging rays of radiation **110** at second focal point **108** of second reflector **104**, reflecting at least part of a portion of rays of radiation **110** that do not impinge directly on reflector **104** toward reflector **104** through first focal point **106** of reflector **104**, positioning an output light pipe **120** having an input surface **122** and output surface **124** so input surface **122** may be substantially proximate to second focal point **108**, collecting rays of radiation at input surface **122**, passing rays of radiation **110** through output light pipe **120**, and outputting rays of radiation **110** from output surface **124** of output light pipe **120**.

While the invention has been described in detail above, the invention is not intended to be limited to the specific embodiments as described. It is evident that those skilled in the art may now make numerous uses and modifications of and departures from the specific embodiments described herein without departing from the inventive concepts.

What is claimed is:

1. An illumination system using filament lamps comprising:

a filament lamp;

a first reflector structure having a first reflector portion with a first focal point, and second reflector portion with a second focal point;

said filament lamp disposed proximate to said first focal point of said first reflector structure to emit rays of electromagnetic radiation that reflect from said first reflector portion to said second reflector portion and then converge substantially at said second focal point; wherein a portion of the electromagnetic radiation emitted by said filament lamp impinges directly on said first reflector structure and a portion of the electromagnetic radiation does not impinge directly on said first reflector structure and wherein said system further comprises an additional reflector constructed and arranged to reflect at least part of the portion of the electromagnetic radiation that does not impinge directly on said first reflector structure toward said first reflector structure.

2. The illumination system of claim 1, wherein said additional reflector comprises a spherical retro-reflector disposed on a side of said filament lamp opposite said first reflector structure to reflect electromagnetic radiation emitted from said filament lamp in a direction away from said additional reflector toward said first reflector structure.

3. The illumination system of claim 1, wherein said additional reflector comprises a paraboloid retro-reflector and a flat reflector;

said paraboloid retro-reflector being disposed on a side of said filament lamp opposite said reflector to reflect electromagnetic radiation emitted from said filament lamp in a direction away from said reflector toward said flat reflector such that said electromagnetic radiation may be reflected by said flat reflector toward said paraboloid retro-reflector.

4. The illumination system of claim 1, wherein said filament lamp comprises a tungsten filament lamp.

6

5. The illumination system of claim 1, wherein said first reflector structure has a coating that reflects substantially only a pre-specified portion of the electromagnetic radiation spectrum.

6. The illumination system of claim 1, wherein said first reflector structure has a coating that reflects substantially only a pre-specified portion of the electromagnetic radiation spectrum selected from the group consisting of: visible light radiation, ultraviolet radiation, infrared radiation, a pre-specified band of wavelengths of radiation, and a specific color of radiation.

7. The illumination system of claim 1, comprising further: an output light pipe having an input surface and an output surface;

said input surface being located proximate to said second focal point to collect substantially all of said radiation; and

wherein said output surface transmits substantially all of said radiation.

8. The illumination system of claim 7, wherein said output light pipe is comprised of a material selected from the group consisting of quartz, glass, plastic, or acrylic.

9. The illumination system of claim 7, wherein said output light pipe is selected from the group consisting of:

a homogenizer,

a tapered light pipe, and

a straight light pipe.

10. The illumination system of claim 7, wherein said output light pipe comprises a cross-section, said cross-section being selected from the group consisting of:

a rectangle,

a circle,

a triangle,

a trapezoid,

a rhombus,

a pentagon,

a hexagon, and

an octagon.

11. The illumination system of claim 7, comprising further a fiber optic, the fiber optic being substantially illuminated by radiation transmitted at said output surface of said output light pipe, the fiber optic releasing the collected and condensed radiation to provide for illumination at a desired location.

12. The illumination system of claim 7, comprising further:

a condenser lens disposed substantially proximate to said output surface of said output light pipe;

an image projection system disposed substantially proximate to an output side of said condenser lens;

an image being illuminated by the radiation transmitted at said output surface of said output light pipe, the projection system releasing the collected and condensed radiation to display the image.

13. The illumination system of claim 1, wherein said first reflector structure comprises a first reflector having a first optical axis and a second reflector having a second optical axis;

said second reflector being placed substantially symmetrically to said first reflector such that said first and second optical axes are substantially collinear; and

wherein said first focal point is a focal point of said first reflector and said second focal point is a focal point of said second reflector.

14. The illumination system of claim 13, wherein said first and second reflectors comprise at least a portion of a substantially ellipsoid surface of revolution.

15. The illumination system of claim 13, wherein said first and second reflectors comprise at least a portion of a substantially toric surface of revolution.

16. The illumination system of claim 13, wherein said first and second reflectors comprise at least a portion of a substantially spheroid surface of revolution.

17. The illumination system of claim 13, wherein said first and second reflectors comprise at least a portion of a substantially paraboloid surface of revolution.

18. The illumination system of claim 13, wherein:

said first reflector comprises at least a portion of a substantially ellipsoid surface of revolution; and  
 said second reflector comprises at least a portion of a substantially hyperboloid surface of revolution.

19. The illumination system of claim 13, wherein:

said first reflector comprises at least a portion of a substantially hyperboloid surface of revolution; and  
 said second reflector comprises at least a portion of a substantially ellipsoid surface of revolution.

20. The illumination system of claim 1, comprising further a waveguide disposed substantially proximate to said output surface, said waveguide selected from the group consisting of:

- a single core optic fiber,
- a fiber bundle,
- a fused fiber bundle,
- a polygonal rod, and
- a hollow reflective light pipe.

21. The illumination system of claim 20, wherein said waveguide is selected from the group consisting of circular waveguides, polygonal waveguides, tapered waveguides and combinations thereof.

22. The illumination system of claim 20, wherein said waveguide is comprised of a material selected from the group consisting of quartz, glass, plastic, or acrylic.

23. The illumination system of claim 1, comprising further a filter placed substantially in a path of said rays of electromagnetic radiation.

24. The illumination system of claim 23, wherein said filter has a coating that reflects substantially only a pre-specified portion of the electromagnetic radiation spectrum.

25. The illumination system of claim 23, wherein said filter has a coating that reflects substantially only a pre-specified portion of the electromagnetic radiation spectrum selected from the group consisting of: visible light radiation, ultraviolet radiation, infrared radiation, a pre-specified band of wavelengths of radiation, and a specific color of radiation.

26. The illumination system of claim 23, wherein said filter has a coating that transmits substantially only a pre-specified portion of the electromagnetic radiation spectrum.

27. The illumination system of claim 23, wherein said filter has a coating that transmits substantially only a pre-specified portion of the electromagnetic radiation spectrum selected from the group consisting of: visible light radiation, ultraviolet radiation, infrared radiation, a pre-specified band of wavelengths of radiation, and a specific color of radiation.

28. A method of illumination comprising the steps of:

- positioning a filament lamp at a first focal point of a first reflector structure;
- producing rays of radiation by said filament lamp;

reflecting a portion of said rays of radiation by said first reflector structure toward a second focal point, wherein said first reflector structure has a first reflector portion with said first focal point, and a second reflector portion with said second focal point, wherein said rays reflect from said first reflector portion to said second reflector portion and then said rays converge substantially at said second focal point;

reflecting at least part of a portion of the rays of radiation that do not impinge directly on said first reflector structure toward said first reflector structure;

positioning an output light pipe having an input surface and an output surface so said input surface is substantially proximate to said second focal point;

collecting said rays of radiation at said input surface;

passing said rays of radiation through said output light pipe; and

outputting rays of radiation from said output surface of said output light pipe.

29. The method of illumination of claim 28, wherein said first reflector structure comprises first and second reflectors; wherein said first focal point is a focal point of said first reflector; and

said second focal point is a focal point of said second reflector.

30. The method of illumination of claim 29, wherein said first and second reflectors comprise at least a portion of a substantially paraboloid surface of revolution.

31. The method of illumination of claim 29, wherein said first and second reflectors comprise at least a portion of a substantially ellipsoid surface of revolution.

32. The method of illumination of claim 29, wherein:

said first reflector comprises at least a portion of a substantially ellipsoid surface of revolution; and  
 said second reflector comprises at least a portion of a substantially hyperboloid surface of revolution.

33. The method of illumination of claim 29, wherein:

said first reflector comprises at least a portion of a substantially hyperboloid surface of revolution; and  
 said second reflector comprises at least a portion of a substantially ellipsoid surface of revolution.

34. The illumination system of claim 1, wherein said first reflector portion and said second reflector portion are at least a portion of a substantially paraboloid surface.

35. The method of illumination of claim 28, wherein said first reflector portion and said second reflector portion are at least a portion of a substantially paraboloid surface.

36. The illumination system of claim 1, wherein said first reflector portion has a first optical axis and said second reflector portion has a second optical axis;

wherein said first reflector portion and said second reflector portion are arranged substantially symmetrically such that said first and second optical axes are substantially collinear.

37. The method of illumination of claim 28, wherein said first reflector portion has a first optical axis and said second reflector portion has a second optical axis;

wherein said first reflector portion and said second reflector portion are arranged substantially symmetrically such that said first and second optical axes are substantially collinear.