



US006882384B1

(12) **United States Patent**  
**Sharp**

(10) **Patent No.:** **US 6,882,384 B1**  
(45) **Date of Patent:** **Apr. 19, 2005**

(54) **COLOR FILTERS AND SEQUENCERS USING COLOR SELECTIVE LIGHT MODULATORS**

- (75) Inventor: **Gary D. Sharp**, Boulder, CO (US)
- (73) Assignee: **ColorLink, Inc.**, Boulder, CO (US)
- (\* ) Notice: Subject to any disclaimer, the term of this patent is extended or adjusted under 35 U.S.C. 154(b) by 0 days.

- (21) Appl. No.: **09/126,330**
- (22) Filed: **Jul. 31, 1998**

**Related U.S. Application Data**

- (63) Continuation-in-part of application No. 08/645,580, filed on May 14, 1996, now Pat. No. 5,822,021.
- (51) **Int. Cl.**<sup>7</sup> ..... **G02G 1/1347**
- (52) **U.S. Cl.** ..... **349/78**
- (58) **Field of Search** ..... 349/74, 78, 79, 349/80

(56) **References Cited**

**U.S. PATENT DOCUMENTS**

|             |          |                  |            |
|-------------|----------|------------------|------------|
| 2,493,200 A | 1/1950   | Land             | 88/112     |
| 2,638,816 A | 5/1953   | Stolzer          | 88/61      |
| 3,647,279 A | * 3/1972 | Sharpless et al. | 349/23     |
| 4,003,081 A | 1/1977   | Hilsum et al.    | 358/64     |
| 4,019,808 A | 4/1977   | Scheffer         | 350/160 LC |
| 4,025,164 A | 5/1977   | Doriguzzi et al. | 350/160 LC |
| 4,232,948 A | 11/1980  | Shanks           | 350/347    |
| 4,367,924 A | 1/1983   | Clark et al.     | 350/334    |
| 4,416,514 A | 11/1983  | Plummer          | 350/335    |
| 4,448,823 A | 5/1984   | Clifford         | 428/1      |
| 4,497,543 A | 2/1985   | Aoki et al.      | 350/337    |
| 4,566,761 A | 1/1986   | Carlsen et al.   | 350/401    |
| 4,575,193 A | 3/1986   | Greivenkamp, Jr. | 350/401    |
| 4,575,470 A | * 3/1986 | Fakirov et al.   | 428/105    |
| 4,582,396 A | 4/1986   | Bos et al.       | 350/347    |
| 4,635,051 A | 1/1987   | Bos et al.       | 340/757    |
| 4,652,087 A | 3/1987   | Bos et al.       | 350/332    |
| 4,659,112 A | * 4/1987 | Reiner et al.    | 283/90     |
| 4,668,086 A | 5/1987   | Redner           | 356/33     |

(Continued)

**FOREIGN PATENT DOCUMENTS**

|    |             |         |        |
|----|-------------|---------|--------|
| DE | 4029838     | 3/1991  | 349/97 |
| JP | 56137307 A  | 10/1981 |        |
| JP | 0121379     | 5/1988  |        |
| JP | 63182987 A  | 7/1988  |        |
| JP | 03028823 A  | 7/1991  |        |
| JP | 4022920     | 1/1992  |        |
| JP | 04207774 A  | 7/1992  |        |
| JP | Hei 7-84218 | 3/1995  |        |
| WO | WO 90/09614 | 8/1990  |        |
| WO | WO95/26110  | 9/1995  |        |

**OTHER PUBLICATIONS**

US 4,917,464, 4/1990, Conner (withdrawn)  
(Continued)

*Primary Examiner*—Kenneth Parker  
(74) *Attorney, Agent, or Firm*—Fleshner & Kim, LLP

(57) **ABSTRACT**

The present invention provides a high brightness color selective light modulator (CSLM) formed by a polarization modulator positioned between two retarder stacks. The modulator changes the apparent orientation of one retarder stack relative to the other so that, in a first switching state of the modulator the two retarder stacks cooperate in filtering the spectrum of input light, and in a second switching state the two retarder stacks complement each other, yielding a neutral transmission spectrum. Two or more CSLM stages can be used in series, each stage providing independent control of a primary color. One preferred embodiment eliminates internal polarizers between CSLM stages, thereby providing an additive common-path full-color display with only two neutral polarizers. Hybrid filters can be made using the CSLMs of this invention, in combination with other active or passive filters. The CSLMs of this invention can be used in many applications, particularly in the areas of recording and displaying color images. They can be arranged in a multi pixel array by pixelating the active elements, and can be implemented as color filter arrays, using patterned passive retarders rather than active polarization modulators.

**64 Claims, 36 Drawing Sheets**

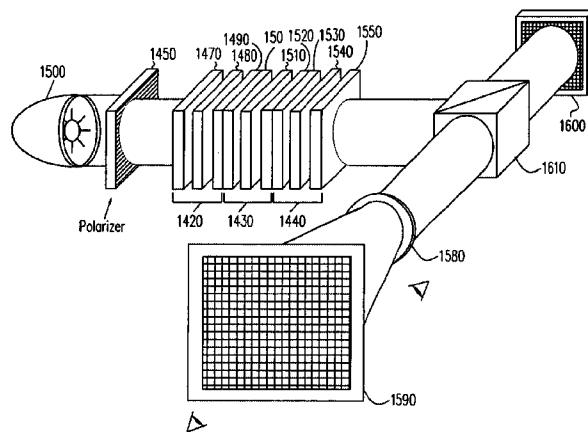

## U.S. PATENT DOCUMENTS

|               |         |                           |            |
|---------------|---------|---------------------------|------------|
| 4,685,773 A   | 8/1987  | Carlsen et al. ....       | 350/401    |
| 4,758,818 A   | 7/1988  | Vatne .....               | 340/701    |
| 4,759,612 A   | 7/1988  | Nakatsuka et al. ....     | 350/337    |
| 4,770,500 A   | 9/1988  | Kalmanash et al. ....     | 350/347 E  |
| 4,770,525 A   | 9/1988  | Umeda et al. ....         | 353/122    |
| 4,786,146 A   | 11/1988 | Ledebuhr .....            | 350/33 IR  |
| 4,786,964 A   | 11/1988 | Plummer                   |            |
| 4,796,978 A   | 1/1989  | Tanaka et al. ....        | 350/337    |
| 4,808,501 A   | 2/1989  | Chiulli                   |            |
| 4,834,508 A   | 5/1989  | Ferguson .....            | 350/339 F  |
| 4,838,655 A * | 6/1989  | Hunahata et al. ....      | 349/5      |
| 4,867,536 A   | 9/1989  | Pidsosny et al. ....      | 350/337    |
| 4,917,465 A * | 4/1990  | Conner et al. ....        | 349/5      |
| 4,966,441 A   | 10/1990 | Conner .....              | 350/335    |
| 4,995,702 A   | 2/1991  | Aruga                     |            |
| 5,032,007 A   | 7/1991  | Silverstein et al. ....   | 350/335    |
| 5,033,825 A   | 7/1991  | Ishikawa et al. ....      | 350/339    |
| 5,050,965 A   | 9/1991  | Conner et al. ....        | 359/53     |
| 5,122,887 A   | 6/1992  | Mathewson .....           | 349/97     |
| 5,124,818 A   | 6/1992  | Conner et al. ....        | 359/53     |
| 5,126,864 A   | 6/1992  | Akiyama et al. ....       | 359/53     |
| 5,132,826 A   | 7/1992  | Johnson et al.            |            |
| 5,164,821 A   | 11/1992 | Tanaka et al. ....        | 358/61     |
| 5,179,459 A   | 1/1993  | Plesinger .....           | 359/74     |
| 5,220,447 A   | 6/1993  | Yokokura et al. ....      | 359/93     |
| 5,231,432 A   | 7/1993  | Glenn                     |            |
| 5,237,435 A   | 8/1993  | Kurematsu et al. ....     | 359/41     |
| 5,243,455 A   | 9/1993  | Johnson et al. ....       | 359/93     |
| 5,249,071 A   | 9/1993  | Yoshimizu et al. ....     | 359/63     |
| 5,268,782 A   | 12/1993 | Wenz et al. ....          | 359/81     |
| 5,276,436 A   | 1/1994  | Shaw et al.               |            |
| 5,298,986 A   | 3/1994  | Owada et al. ....         | 348/762    |
| 5,299,039 A   | 3/1994  | Bohannon .....            | 359/53     |
| 5,321,450 A   | 6/1994  | Shapiro et al.            |            |
| 5,325,218 A * | 6/1994  | Willett et al. ....       | 349/74     |
| 5,337,103 A   | 8/1994  | Gulick                    |            |
| 5,337,174 A   | 8/1994  | Wada et al. ....          | 359/73     |
| 5,347,378 A   | 9/1994  | Handschy et al. ....      | 359/53     |
| 5,353,075 A   | 10/1994 | Connor et al.             |            |
| 5,355,188 A   | 10/1994 | Biles et al.              |            |
| 5,369,513 A   | 11/1994 | Akatsuka et al. ....      | 359/73     |
| 5,381,253 A   | 1/1995  | Sharp et al.              |            |
| 5,387,920 A   | 2/1995  | Bos et al. ....           | 345/88     |
| 5,400,095 A   | 3/1995  | Minich et al.             |            |
| 5,406,396 A * | 4/1995  | Akatsuka et al. ....      | 349/118    |
| 5,422,756 A   | 6/1995  | Weber .....               | 359/487    |
| 5,469,279 A   | 11/1995 | Sharp et al. ....         | 359/53     |
| 5,481,320 A   | 1/1996  | Konuma et al. ....        | 348/751    |
| 5,500,523 A   | 3/1996  | Hamanaka .....            | 250/216    |
| 5,510,861 A   | 4/1996  | Minich et al.             |            |
| 5,528,393 A   | 6/1996  | Sharp et al. ....         | 359/53     |
| 5,559,634 A   | 9/1996  | Weber .....               | 359/638    |
| 5,565,933 A   | 10/1996 | Reinsch .....             | 348/742    |
| 5,574,580 A   | 11/1996 | Ansley .....              | 359/41     |
| 5,585,950 A   | 12/1996 | Nishino et al. ....       | 349/118    |
| 5,608,551 A   | 3/1997  | Biles et al. ....         | 359/95     |
| 5,627,666 A   | 5/1997  | Sharp et al. ....         | 349/74     |
| 5,658,490 A   | 8/1997  | Sharp et al. ....         | 252/299.01 |
| 5,671,211 A * | 9/1997  | Akashi et al. ....        | 369/275.1  |
| 5,686,931 A   | 11/1997 | Fünfschilling et al. .... | 345/88     |
| 5,689,317 A   | 11/1997 | Miller .....              | 349/97     |
| 5,739,881 A   | 4/1998  | Xu et al. ....            | 349/118    |
| 5,774,264 A   | 6/1998  | Konno et al. ....         | 359/497    |
| 5,777,709 A   | 7/1998  | Xu .....                  | 349/120    |
| 5,888,603 A   | 3/1999  | Ferguson .....            | 428/46     |
| 6,057,901 A * | 5/2000  | Xu .....                  | 349/121    |

6,078,363 A 6/2000 Masuda et al. .... 348/752

## OTHER PUBLICATIONS

Bernard M. Schiffman, et al., "Birefringent Filter For Millimeter Waves," IEEE Transactions on Microwave Theory and Techniques, vol. MIT-16, No. 6, Jun. 1968.

Scheffer, T.J., "New multicolor liquid crystal displays that use a twisted nematic electro-optical cell," J. Appl. Phys. (1973) 44(11):4799-4803.

Carlsen, W.J. and Buhner, C.F., "Flat Passband Birefringent Wavelength-Division Multiplexers," Electronics Letters (1987) 23(3):106-107.

Wright, H., et al., "Active filters enable color imaging," Laser Focus World (May 1996) 85-90.

Cambridge Research & Instrumentation, Inc., "Liquid Crystal Tunable Filter," Cambridge, MA, 2 pages.

Displaytech, Inc. (Jan., 1996), "Switchable Color Filter", Boulder, CO, 4 pages.

Title, A.M. and Rosenberg, W.J., "Tunable birefringent filters," Opt. Eng., (1981) 20(6):815-823.

Solc, Ivan, "Birefringent Chain Filters," J. Opt. Soc. Am. (1965) 55(6):621-625.

Wu, Shin-Ison, "Birefringence dispersions of liquid crystals," Physical Review A, (1986) 33(2):1270-1274.

Harris, S.E., et al., "Optical Network Synthesis Using Birefringent Crystals, I. Synthesis of Lossless Networks of Equal-Length Crystal," J. Opt. Soc. America (1964) 54(10):1267-1279.

Amman, E.O., "Optical Network Synthesis Using Birefringent Crystals, III., Some General Properties of Lossless Birefringent Networks," J. Opt. Soc. America (1966) 56(7):943-951.

Amman, E.O. and Yarborough, J.M., "Optical Network Synthesis Using Birefringent Crystals V. Synthesis of Lossless Networks Containing Equal-Length Crystals and Compensators," J. Opt. Soc. America (1966) 56(12): 1746-1754.

Sharp, G.D., et al., "P-60: Color Switching Using Ferroelectric Liquid Crystals," Society for Information Display, International Symposium, Digest of Technical Papers, Vo., XXIV, Seattle, Washington, May 18-20, 1993.

Kondo, et al., "Ferroelectric Liquid Crystal Materials Applied to Guest-Host Type Displays," Ferroelectrics (1988) 85:361-373.

Billings, B.H., "A Tunable Narrow-Band Optical Filter," J., Opt. Soc. America (1947) 37:738-746.

Buhner, Carl F., "Synthesis and tuning of high-order birefringent filters," Applied Optics (Apr. 20, 1994) 33(12): 2249-2254.

Sharp, Gary Dean, "Chiral smectic liquid crystal tunable optical filters and modulators", 1992.

"Achromatic phase-shifters: 2. A quantized ferroelectric liquid-crystal system", P. Hariharan et al., 2319 Optics Communications 117 (1995) May 15, Nos. 1/2, Amsterdam, NL, pp. 13-15.

"Achromatic retardation plates", Alan M. Title et al., SIPE vol. 307 Polarizers and Applications (1981), pp. 120-125.

"Improvement of Birefringent Filters. 2: Achromatic Waveplates", Alan M. Title, Jan. 1975/ vol. 14 No. 1/ Applied Optics, pp. 229-237.

\* cited by examiner

|    | Type          | Stack Only | Stack Altered | Additive Primaries Switched | Stack Altered Behavior                      |
|----|---------------|------------|---------------|-----------------------------|---|
|    |               | Output     | Output        |                             |   |
| 1  | RED/BLACK     | RED        | BLACK         | 1                           | Moderate loss in black density              |
| 2  | RED/BLACK     | BLACK      | RED           | 1                           | High density black, nearly ideal red        |
| 3  | RED/WHITE     | RED        | WHITE         | 2                           | Significant white loss (B,G)                |
| 4  | RED/WHITE     | WHITE      | RED           | 2                           | Significant degradation in color coordinate |
| 5  | GREEN/BLACK   | GREEN      | BLACK         | 1                           | Moderate loss in black density              |
| 6  | GREEN/BLACK   | BLACK      | GREEN         | 1                           | High density black, nearly ideal green      |
| 7  | GREEN/WHITE   | GREEN      | WHITE         | 3                           | High white loss (B,R)                       |
| 8  | GREEN/WHITE   | WHITE      | GREEN         | 3                           | Severe degradation in color coordinate      |
| 9  | BLUE/BLACK    | BLUE       | BLACK         | 1                           | Moderate loss in black density              |
| 10 | BLUE/BLACK    | BLACK      | BLUE          | 1                           | High density black, nearly ideal blue       |
| 11 | BLUE/WHITE    | BLUE       | WHITE         | 2                           | Significant white loss (G,R)                |
| 12 | BLUE/WHITE    | WHITE      | BLUE          | 2                           | Significant degradation in color coordinate |
| 13 | CYAN/BLACK    | CYAN       | BLACK         | 2                           | Significant loss in black density           |
| 14 | CYAN/BLACK    | BLACK      | CYAN          | 2                           | Significant passband loss (B,G)             |
| 15 | CYAN/WHITE    | CYAN       | WHITE         | 1                           | Small ripple in red                         |
| 16 | CYAN/WHITE    | WHITE      | CYAN          | 1                           | Flat white, nearly ideal cyan               |
| 17 | MAGENTA/BLACK | MAGENTA    | BLACK         | 3                           | High loss in black density                  |
| 18 | MAGENTA/BLACK | BLACK      | MAGENTA       | 3                           | High passband loss (B,R)                    |
| 19 | MAGENTA/WHITE | MAGENTA    | WHITE         | 1                           | Small ripple in green                       |
| 20 | MAGENTA/WHITE | WHITE      | MAGENTA       | 1                           | Flat white, nearly ideal magenta            |
| 21 | YELLOW/BLACK  | YELLOW     | BLACK         | 2                           | Significant loss in black density           |
| 22 | YELLOW/BLACK  | BLACK      | YELLOW        | 2                           | Significant passband loss(G,R)              |
| 23 | YELLOW/WHITE  | YELLOW     | WHITE         | 1                           | Small ripple in blue                        |
| 24 | YELLOW/WHITE  | WHITE      | YELLOW        | 1                           | Flat white, nearly ideal yellow             |

FIG. 1

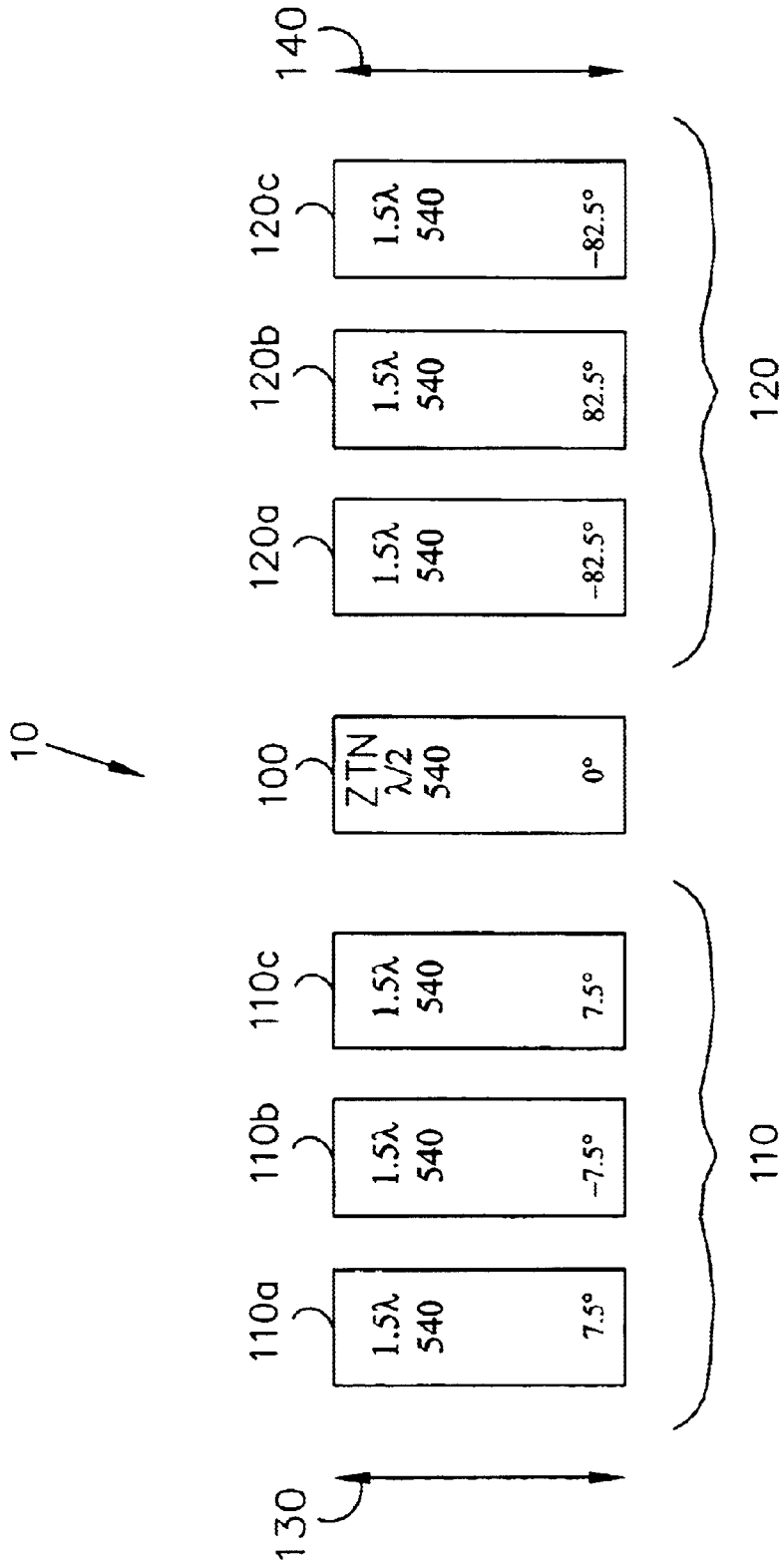

FIG. 2

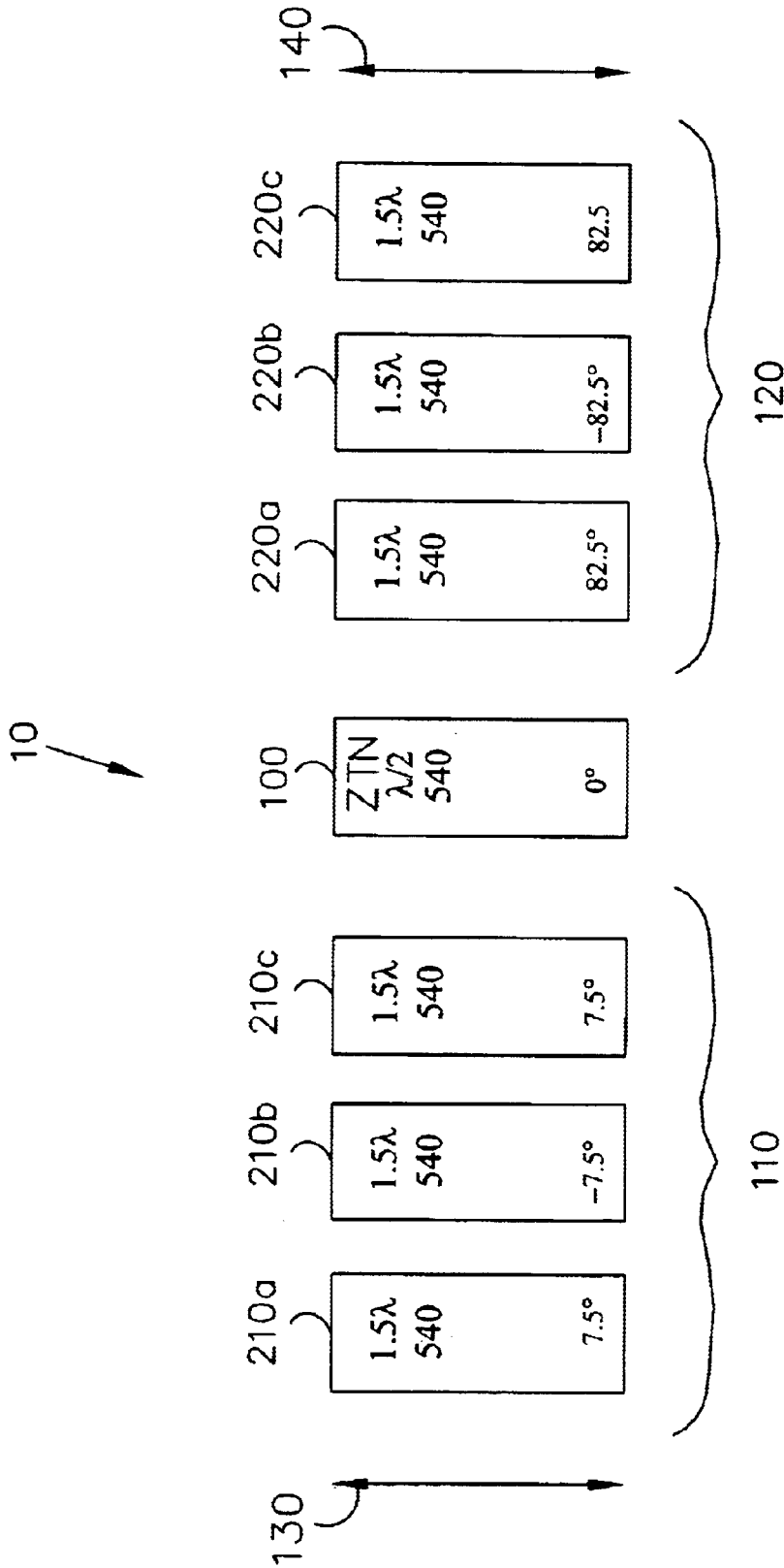

FIG. 3

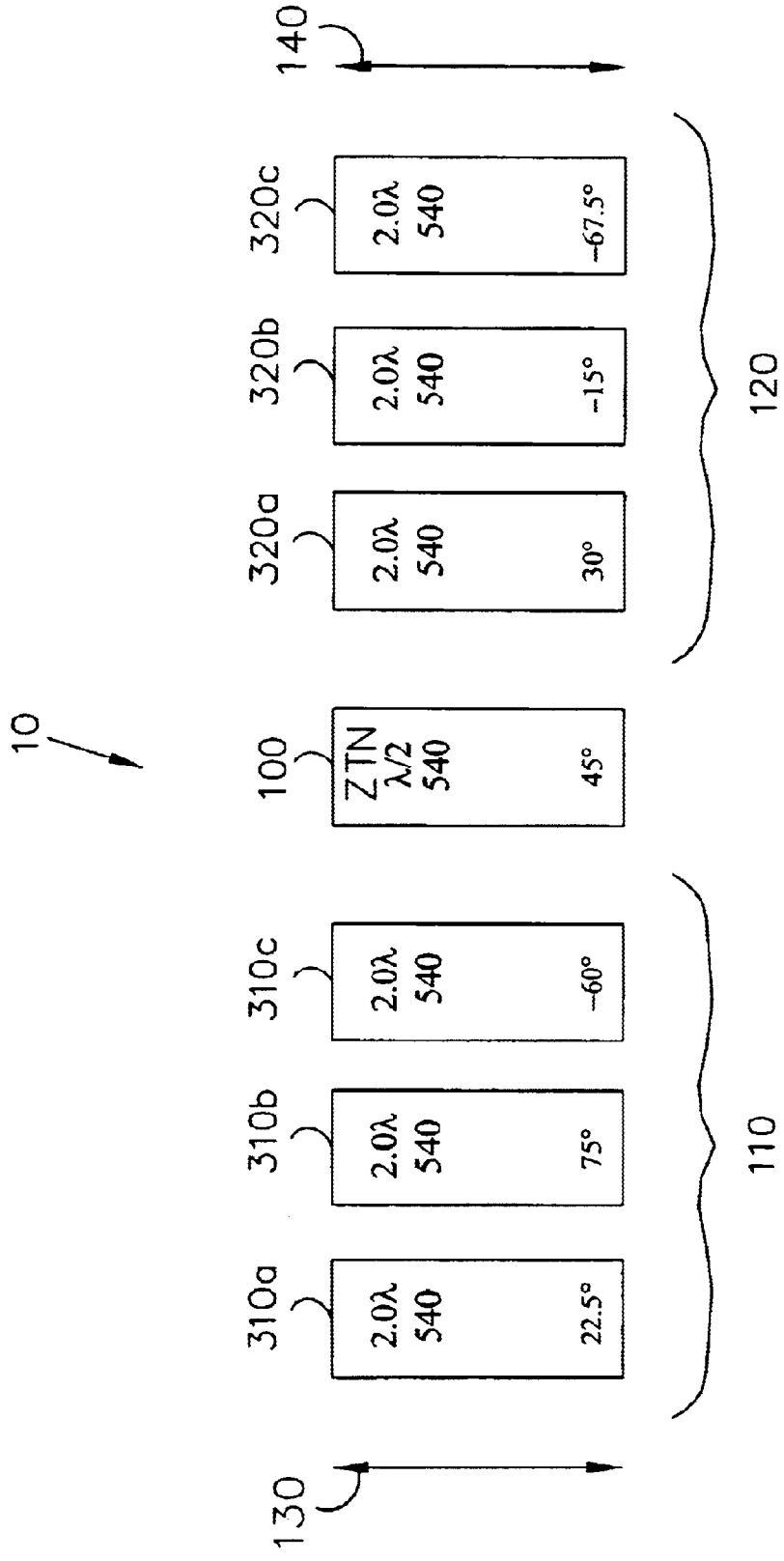

FIG. 4

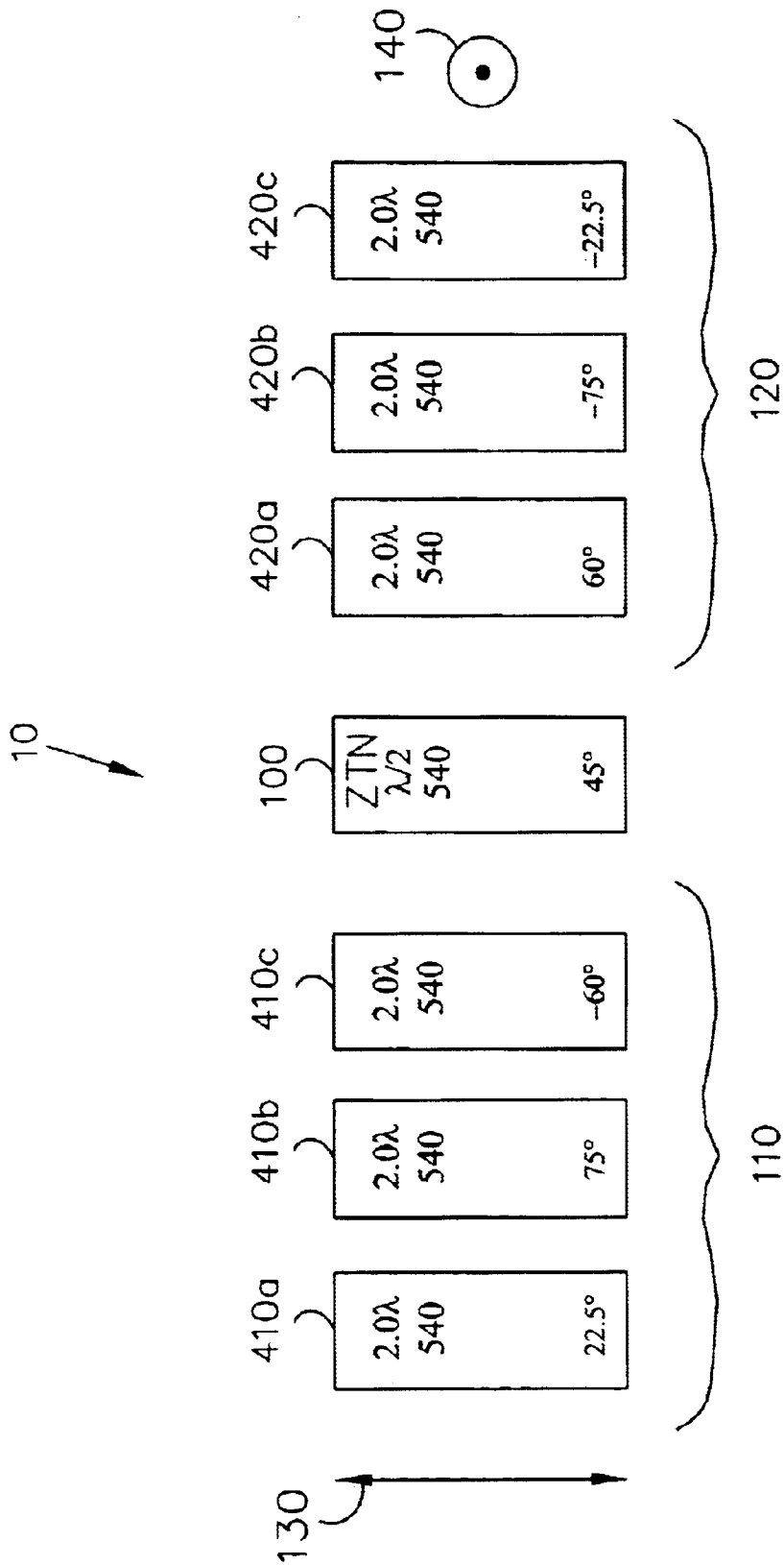

FIG. 5

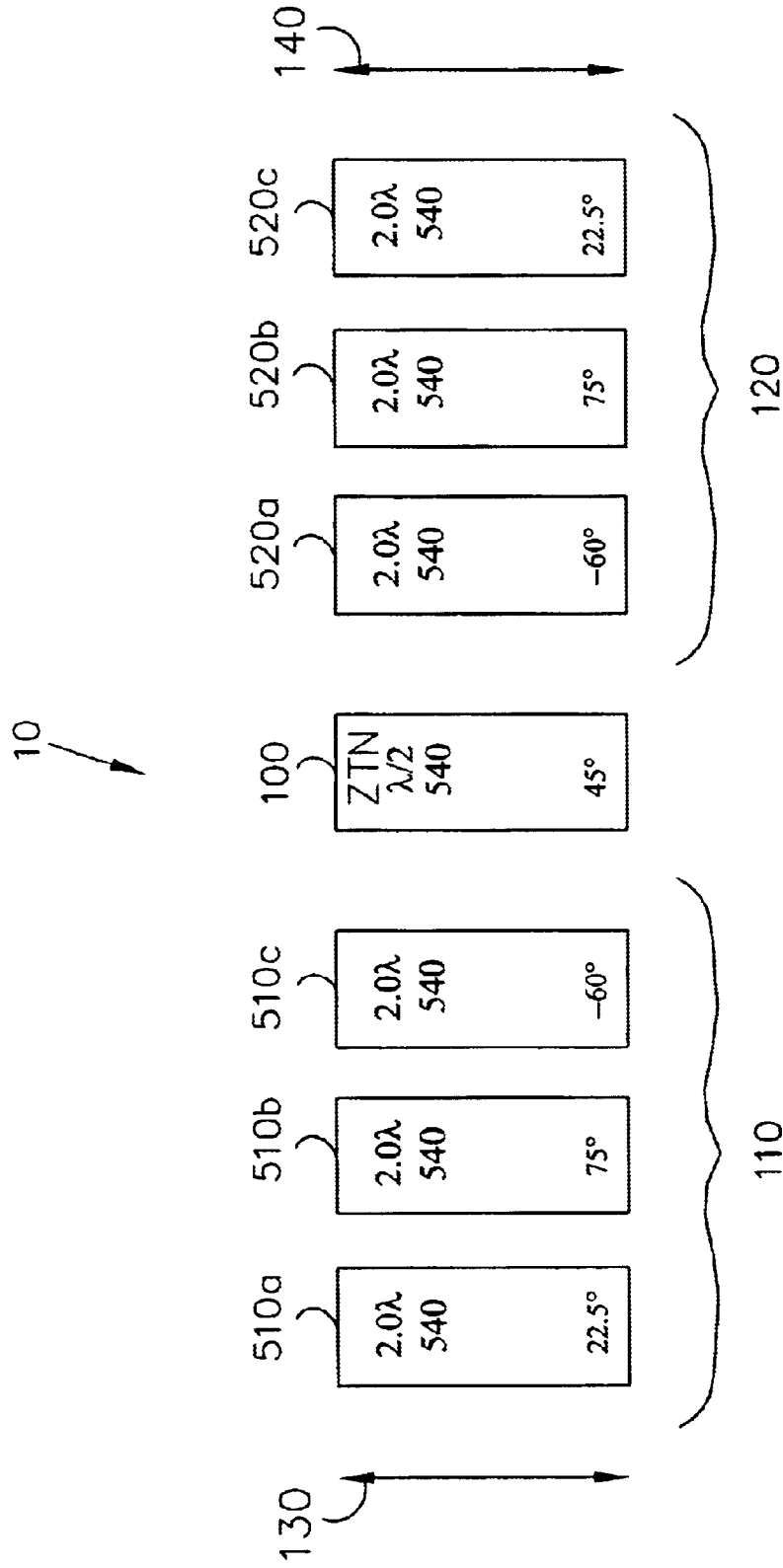

FIG. 6

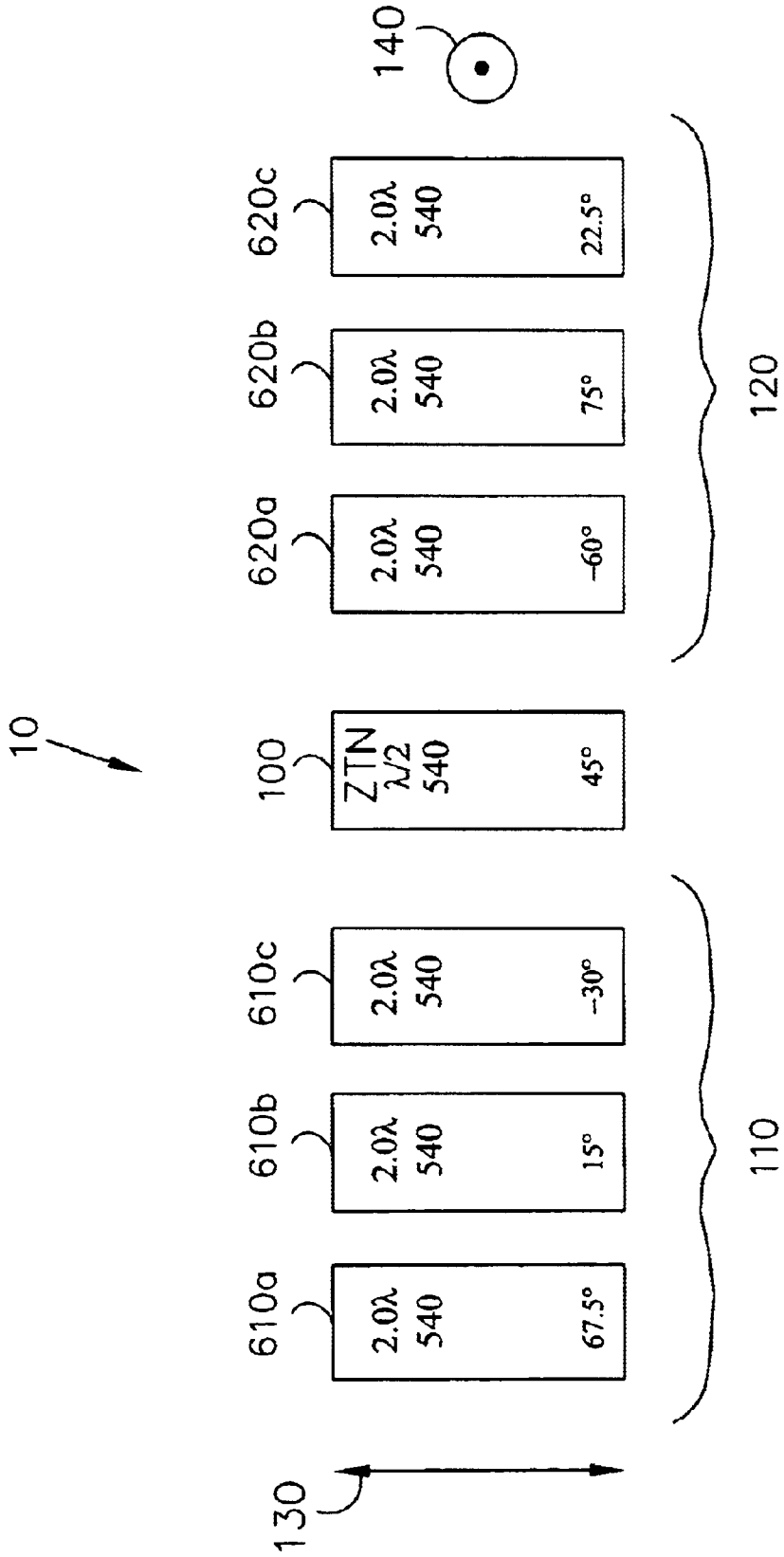

FIG. 7

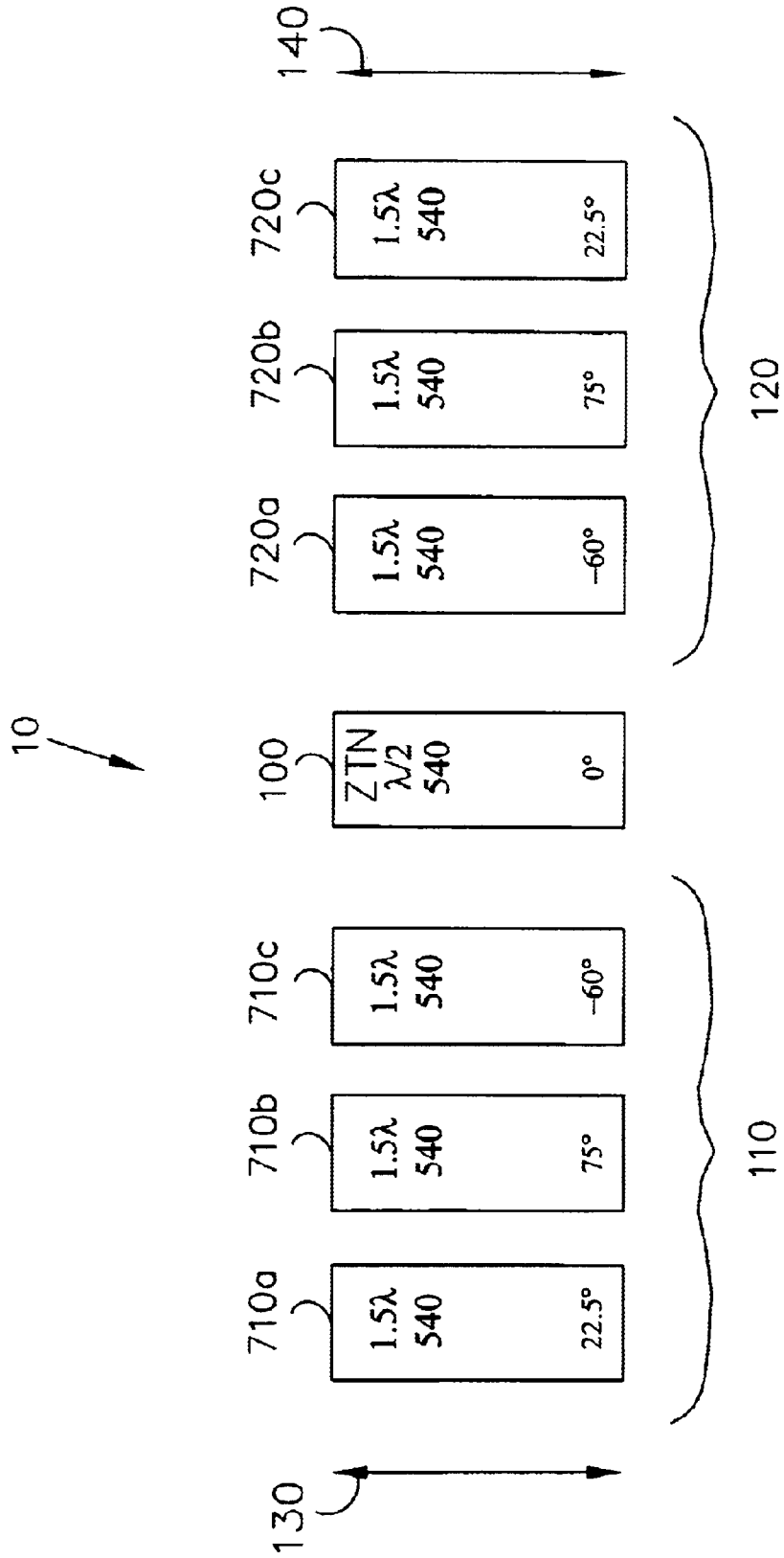

FIG. 8

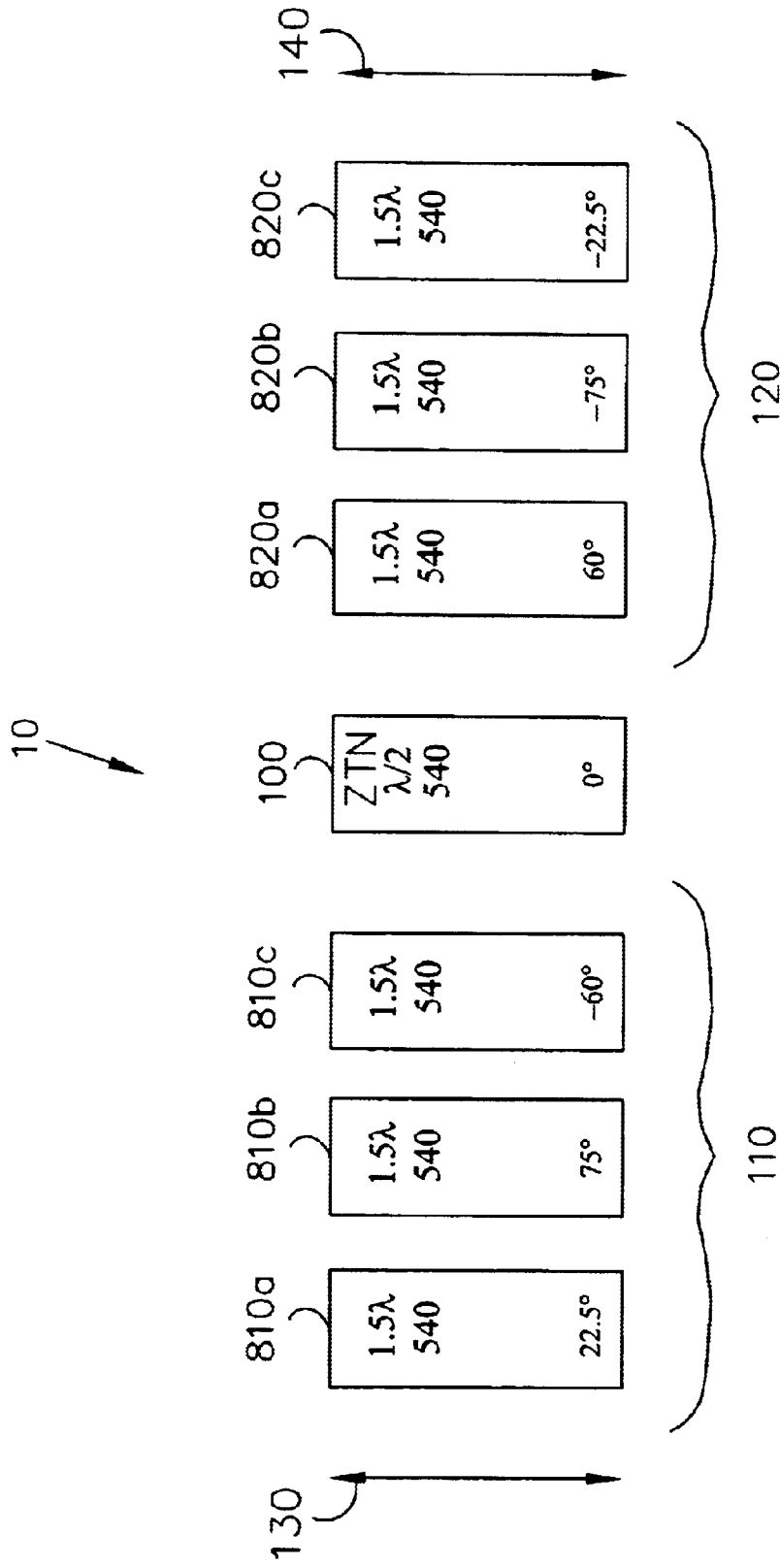

FIG. 9

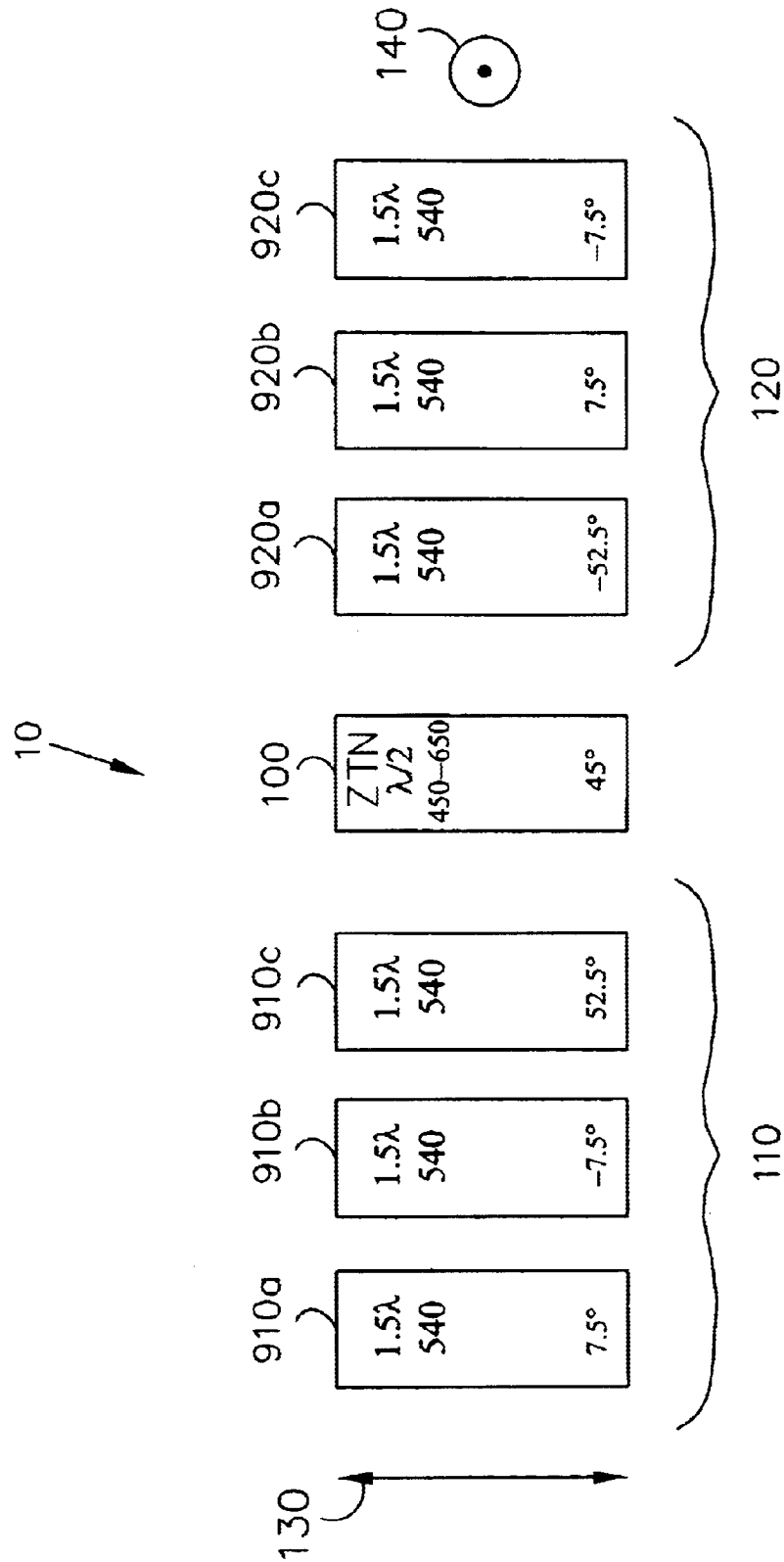

FIG. 10

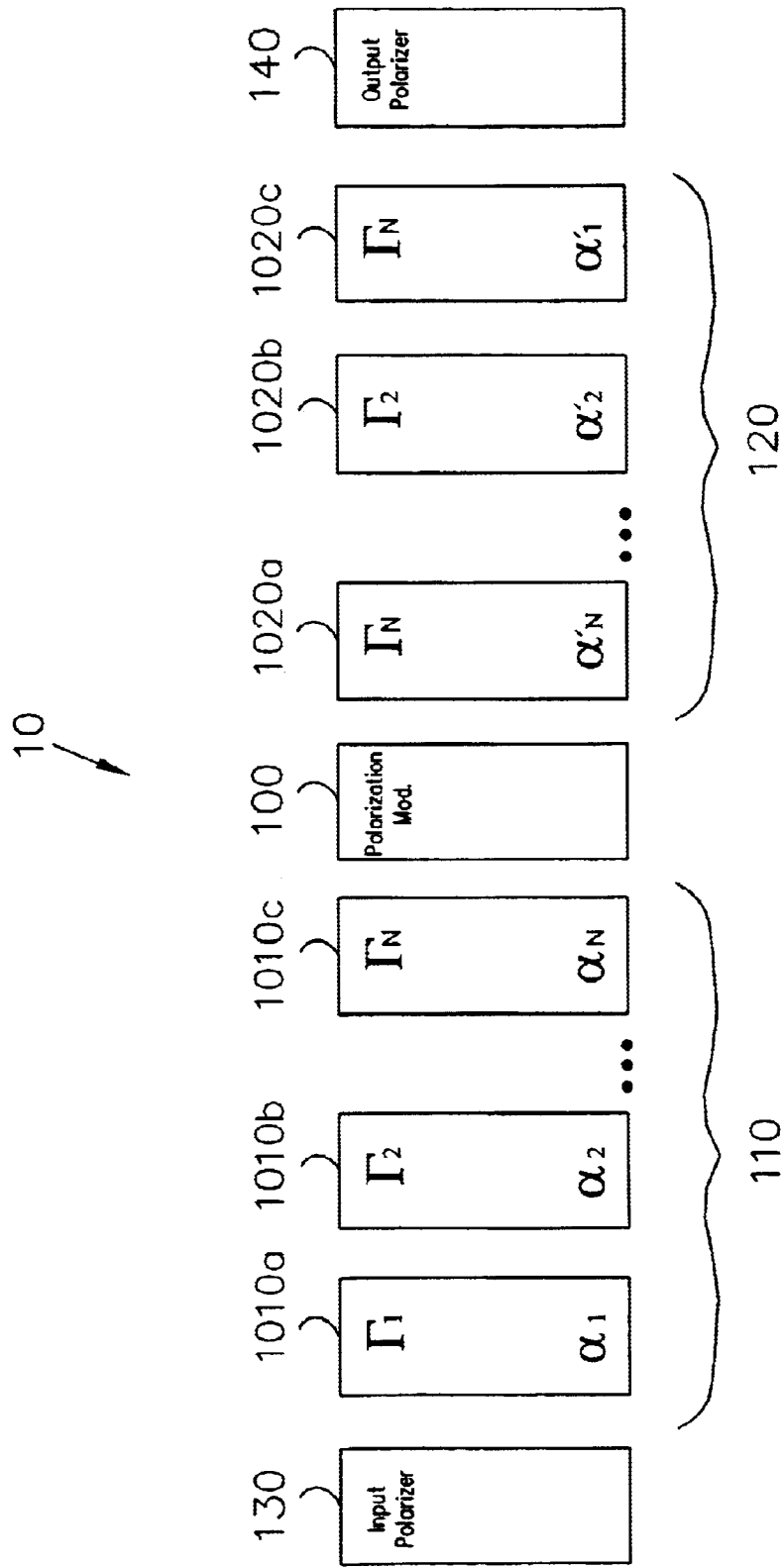

FIG. 11

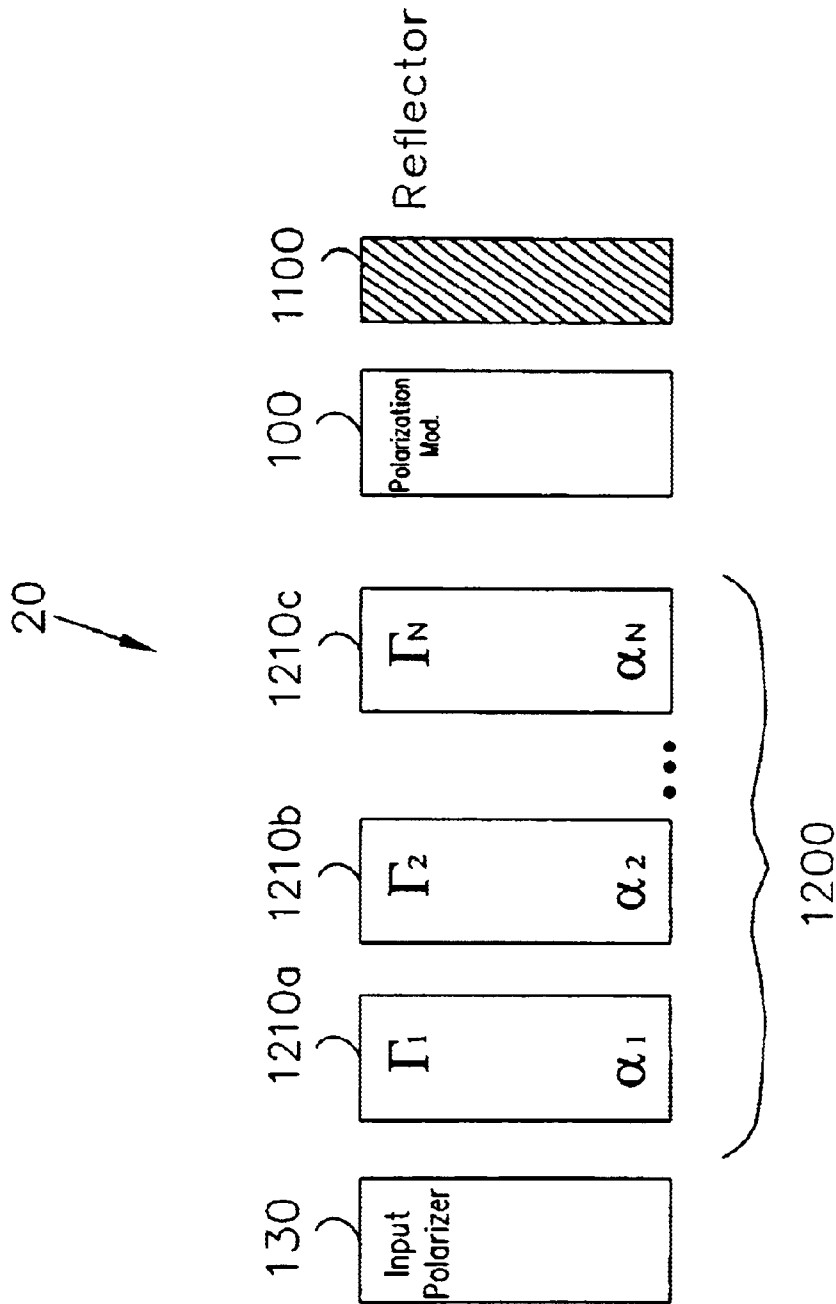

FIG. 12

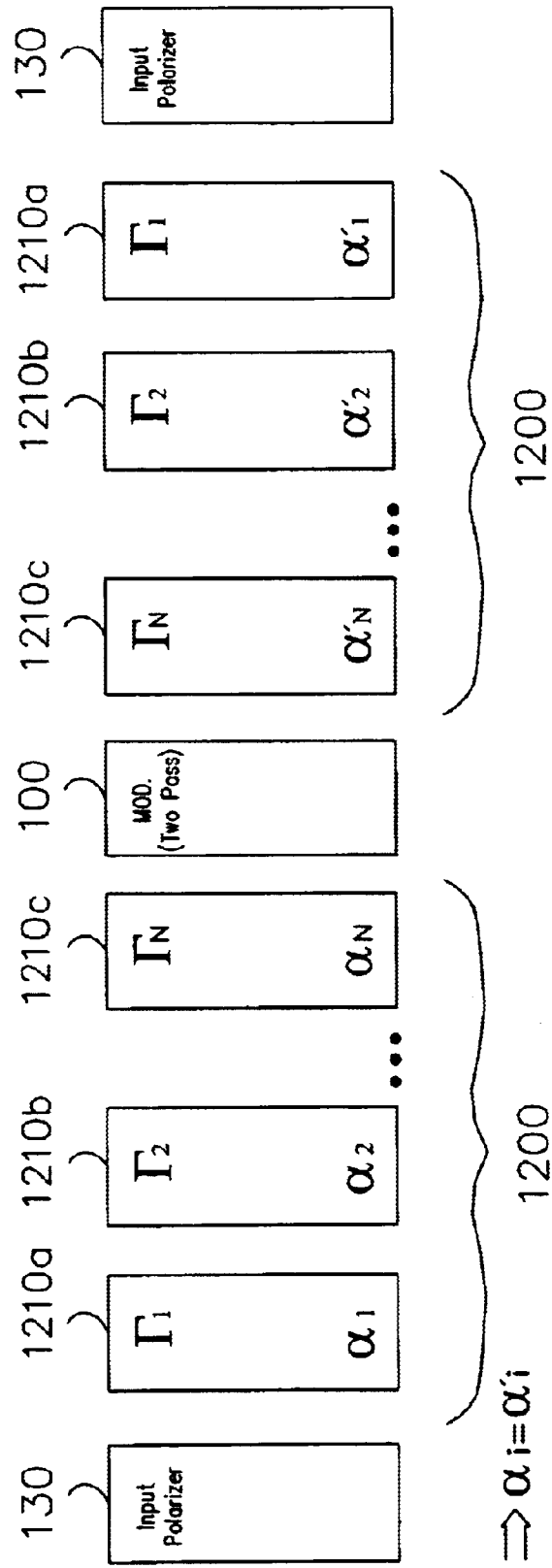

FIG. 13

| Design # | $\alpha_1$ | $\alpha_2$ | $\alpha_3$ |
|----------|------------|------------|------------|
| 1        | 7.5°       | -37.5°     | 22.5°      |
| 2        | 7.5°       | -30.0°     | 30.0°      |
| 3        | 7.5°       | 52.5°      | -67.5°     |
| 4        | 15.0°      | -45.0°     | 7.5°       |
| 5        | 15.0°      | -37.5°     | 15.0°      |
| 6        | 15.0°      | -30.0°     | 22.5°      |
| 7        | 15.0°      | 60.0°      | -67.5°     |
| 8        | 22.5°      | -30.0°     | 15.0°      |

FIG. 14

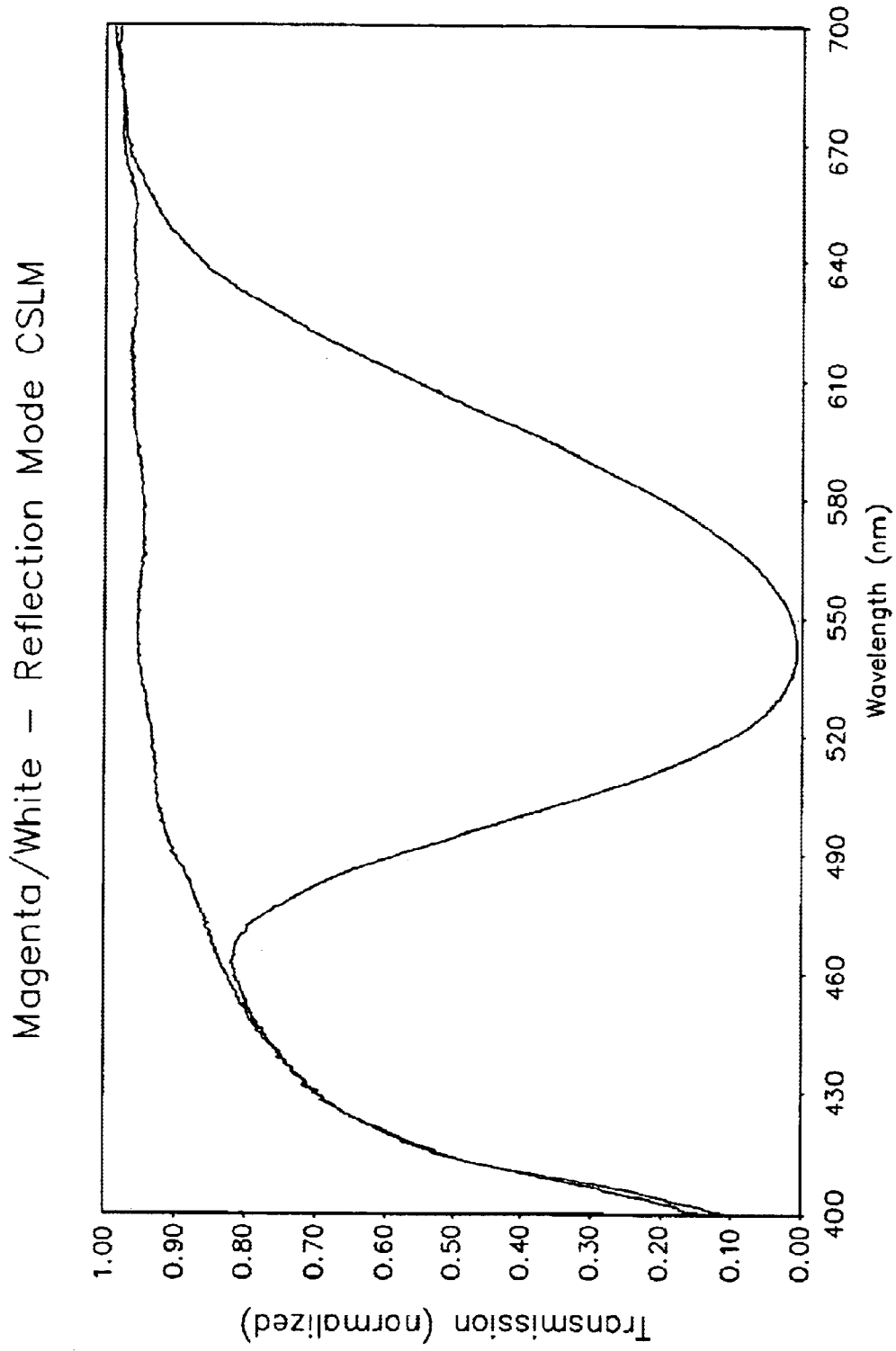

FIG. 15A

Yellow/White – Reflection Mode CSLM

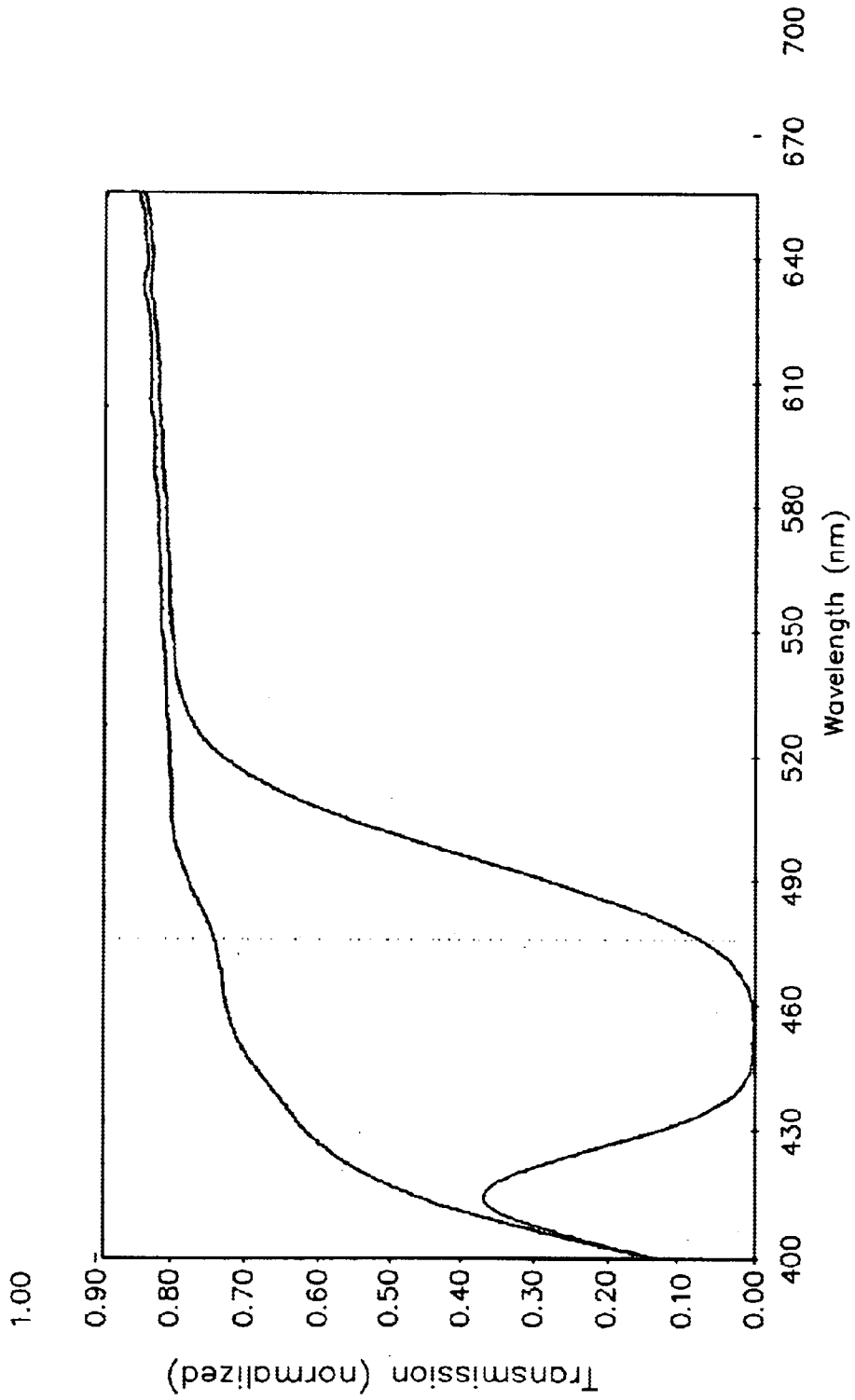

FIG. 15B

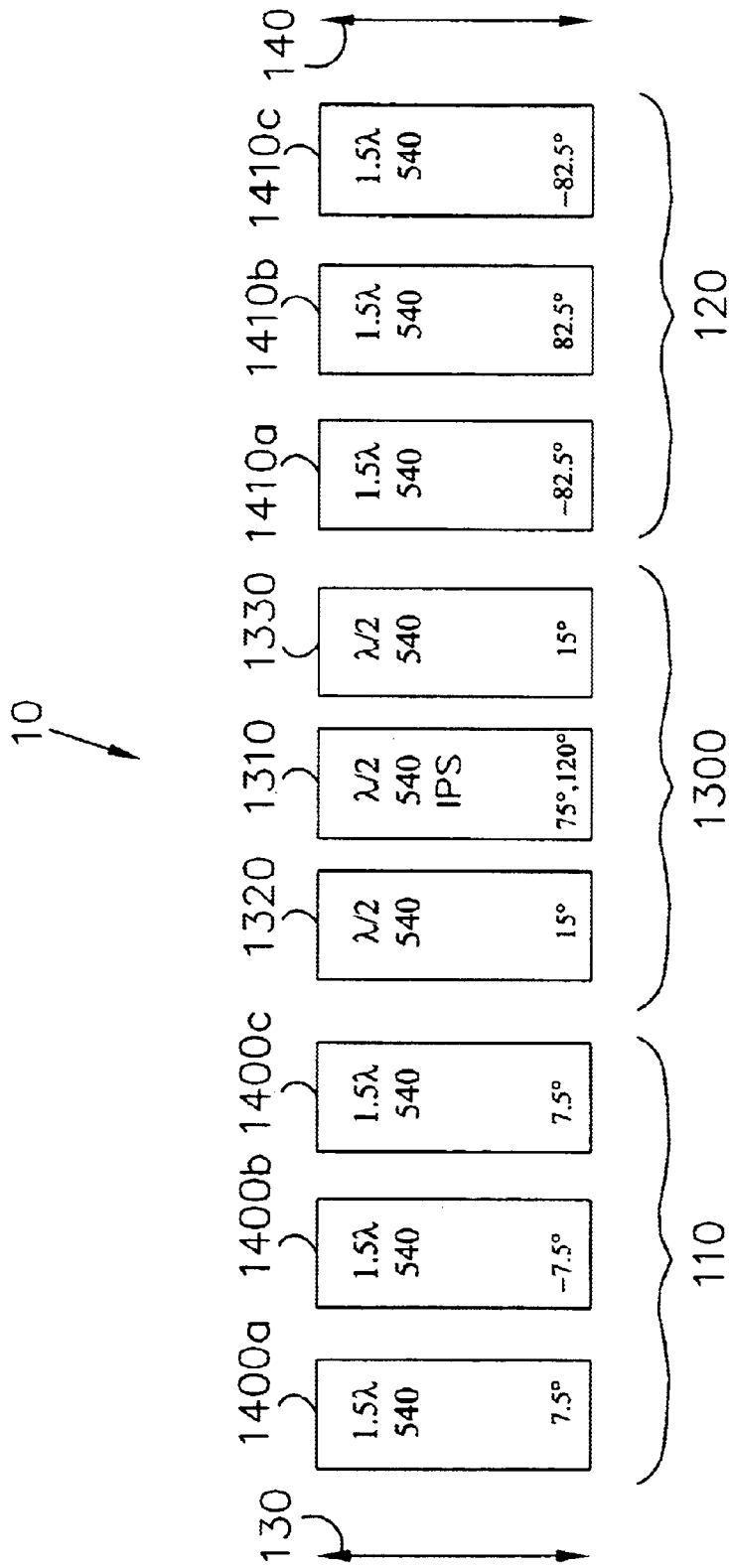

FIG. 16

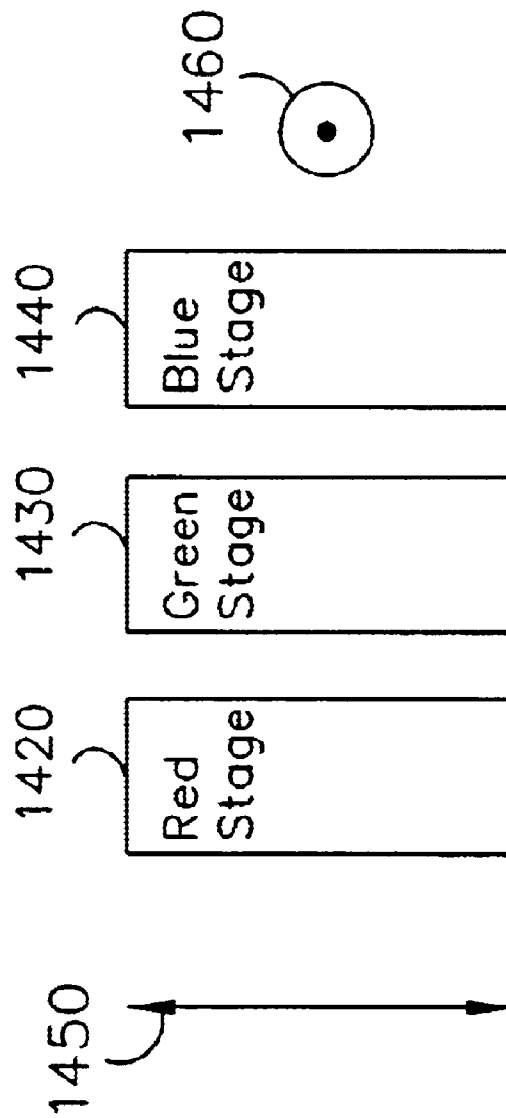

FIG. 17A

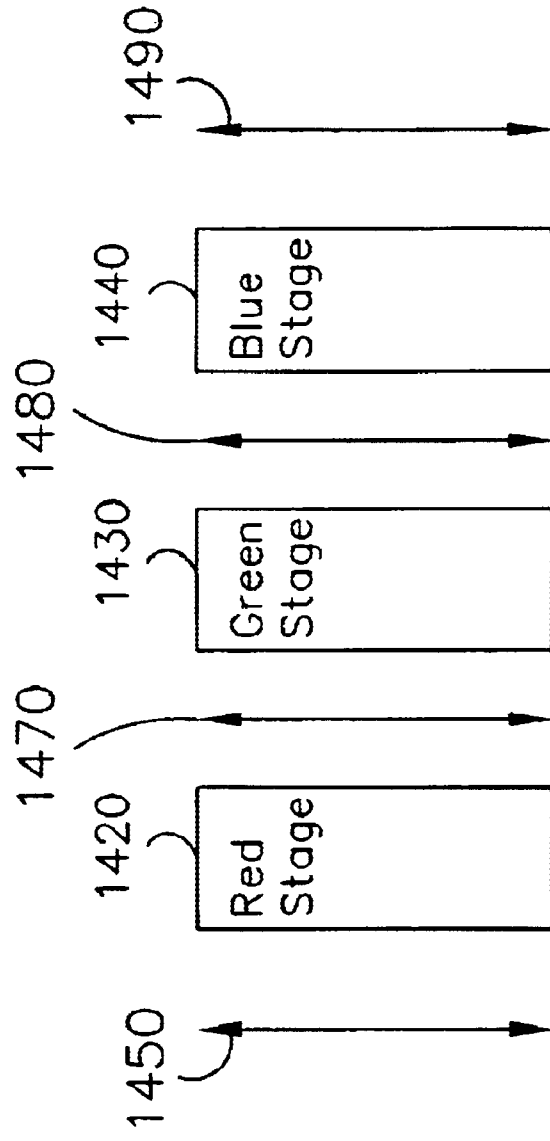

FIG. 17B

|     |      |     |      |     |      |     |     |     |     |     |     |     |      |     |      |     |      |     |
|-----|------|-----|------|-----|------|-----|-----|-----|-----|-----|-----|-----|------|-----|------|-----|------|-----|
| 1λ  | 1λ   | 1λ  | 1λ   | 1λ  | 1λ   | 1λ  | 1λ  | 1λ  | 1λ  | 1λ  | 1λ  | 1λ  | 1λ   | 1λ  | 1λ   | 1λ  | 1λ   | 1λ  |
| 600 | 600  | 600 | 600  | 600 | 600  | 600 | 600 | 600 | 600 | 600 | 600 | 600 | 600  | 600 | 600  | 600 | 600  | 600 |
| 8°  | -82° | 82° | -82° | 90° | 90°  | 6°  | -6° | 84° | 84° | 84° | 84° | 15° | -15° | 8°  | -82° | 75° | -75° | 82° |
|     |      |     |      | LC  | MOD. |     |     |     |     |     |     |     |      |     |      |     |      |     |

FIG. 18

CCS Truth Table

| 1 Blue Modulator | 2 Green Modulator | 3 Red Modulator | Output  |
|------------------|-------------------|-----------------|---------|
| Off              | Off               | Off             | Black   |
| Off              | Off               | On              | Red     |
| Off              | On                | Off             | Green   |
| On               | Off               | Off             | Blue    |
| On               | On                | On              | White   |
| On               | On                | Off             | Cyan    |
| On               | Off               | On              | Magenta |
| Off              | On                | On              | Yellow  |

FIG. 19

CSLM Sequencer - Red

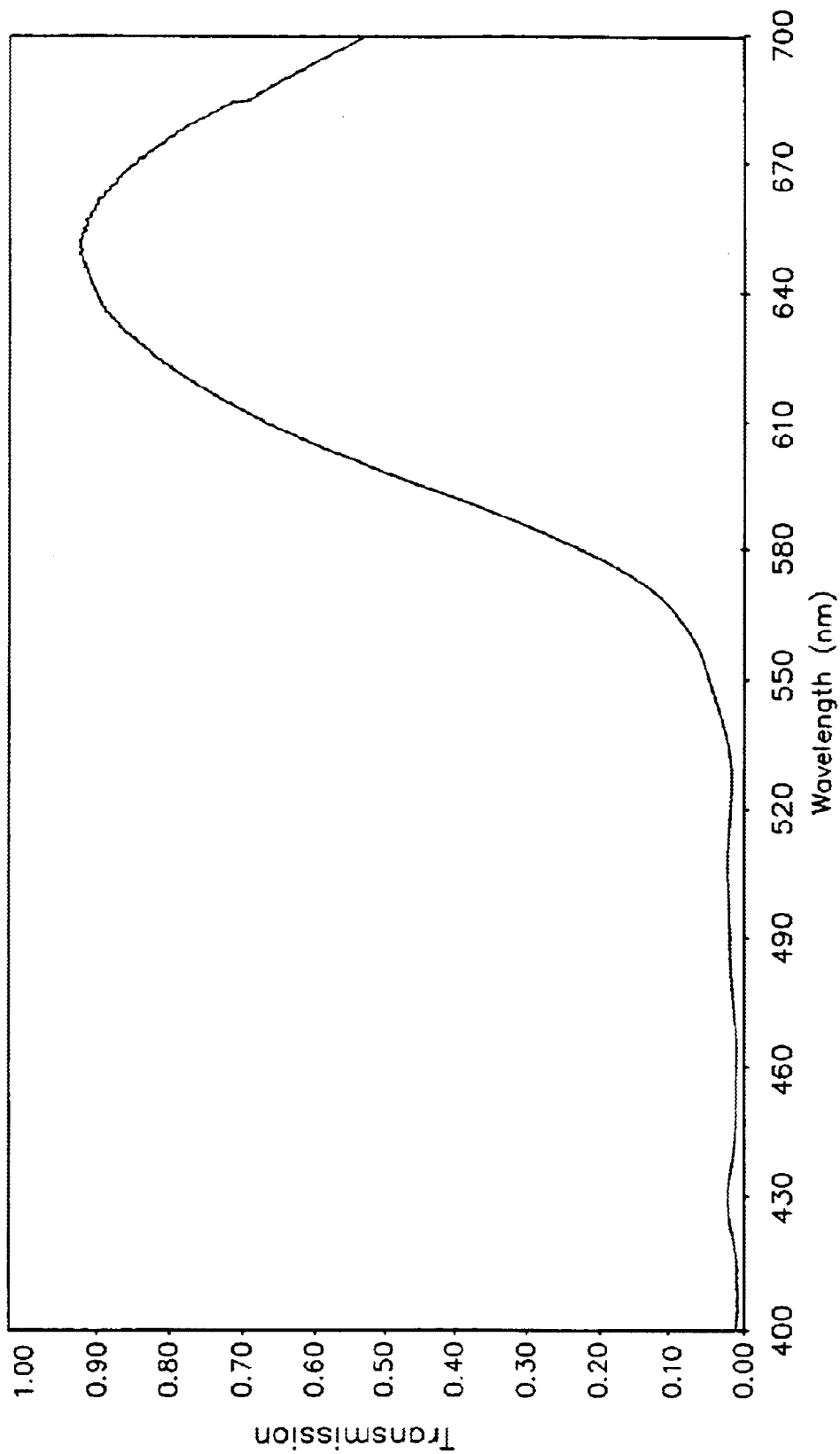

FIG. 20A

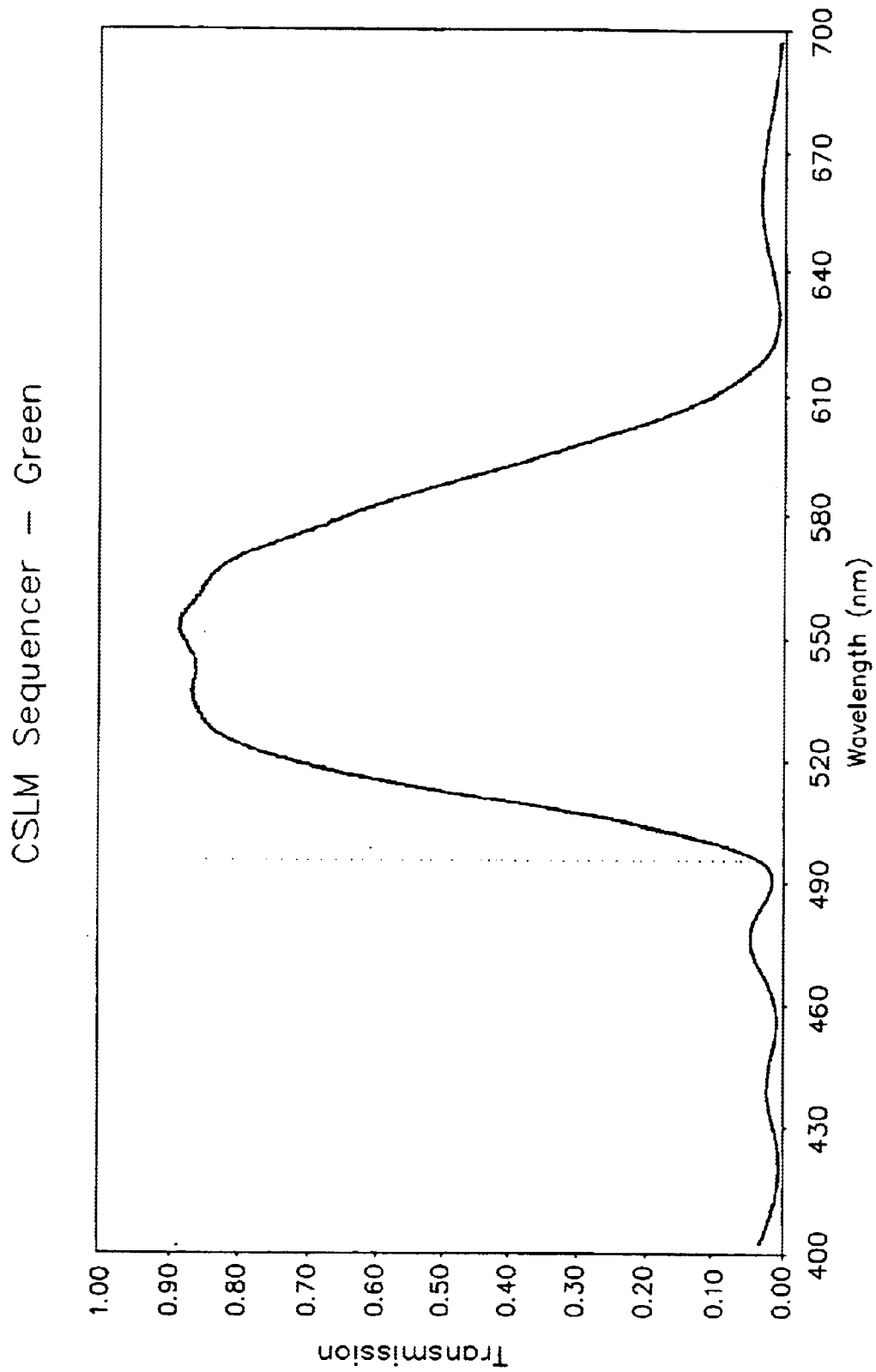

FIG. 20B

CSLM Sequencer - Blue

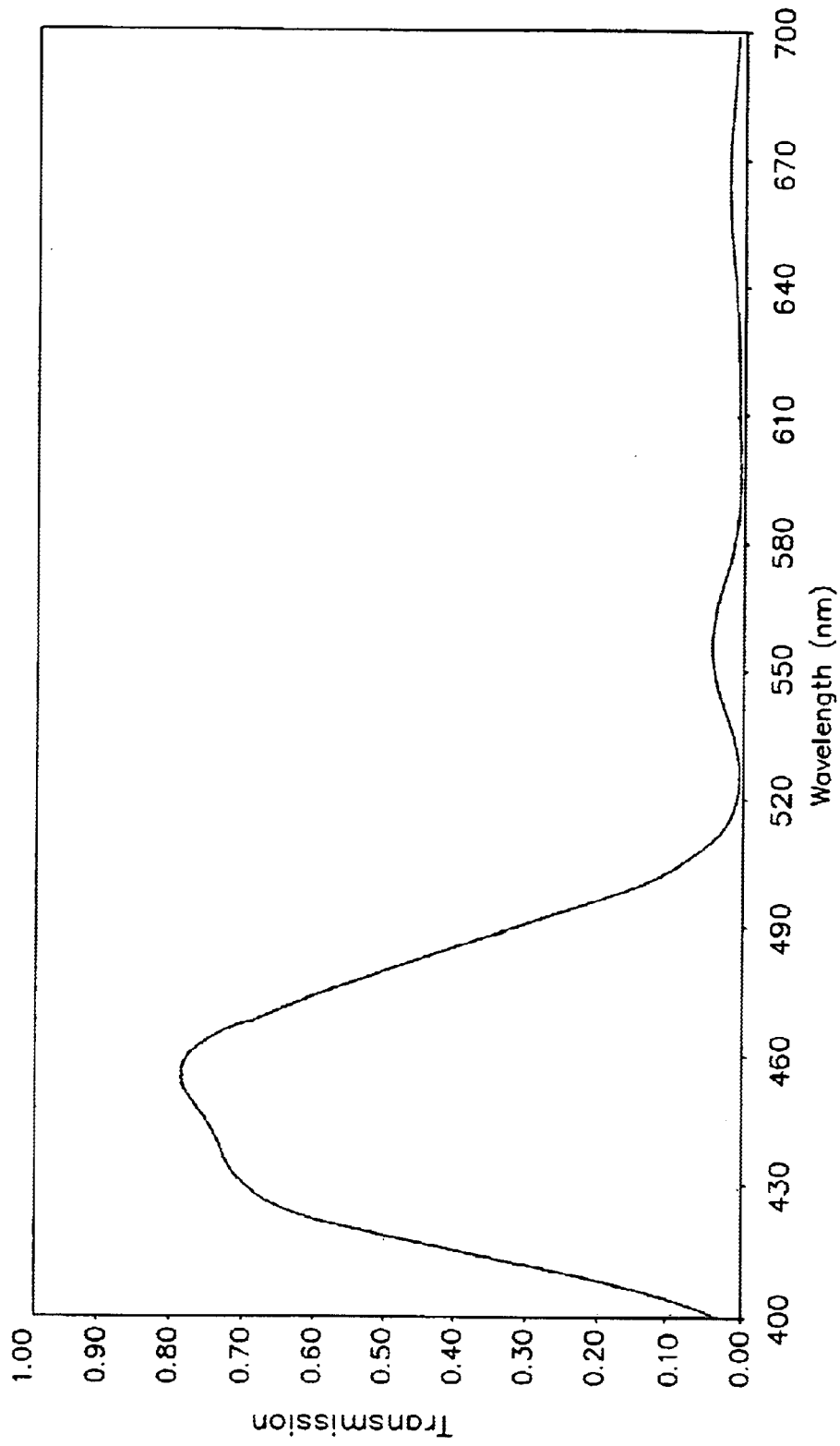

FIG. 20C

CSLM Sequencer - Cyan

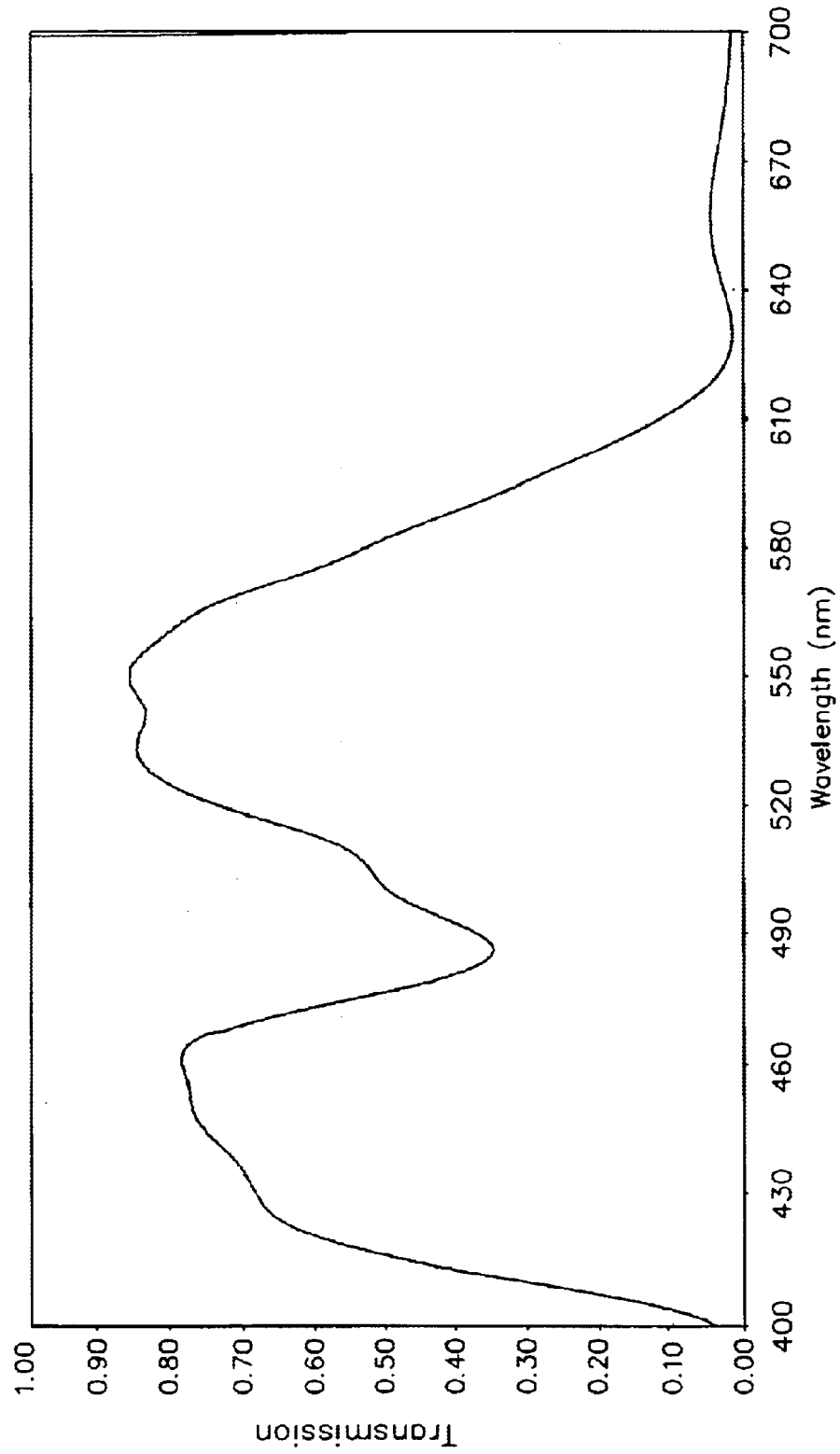

FIG. 21A

CSLM Sequencer – Magenta

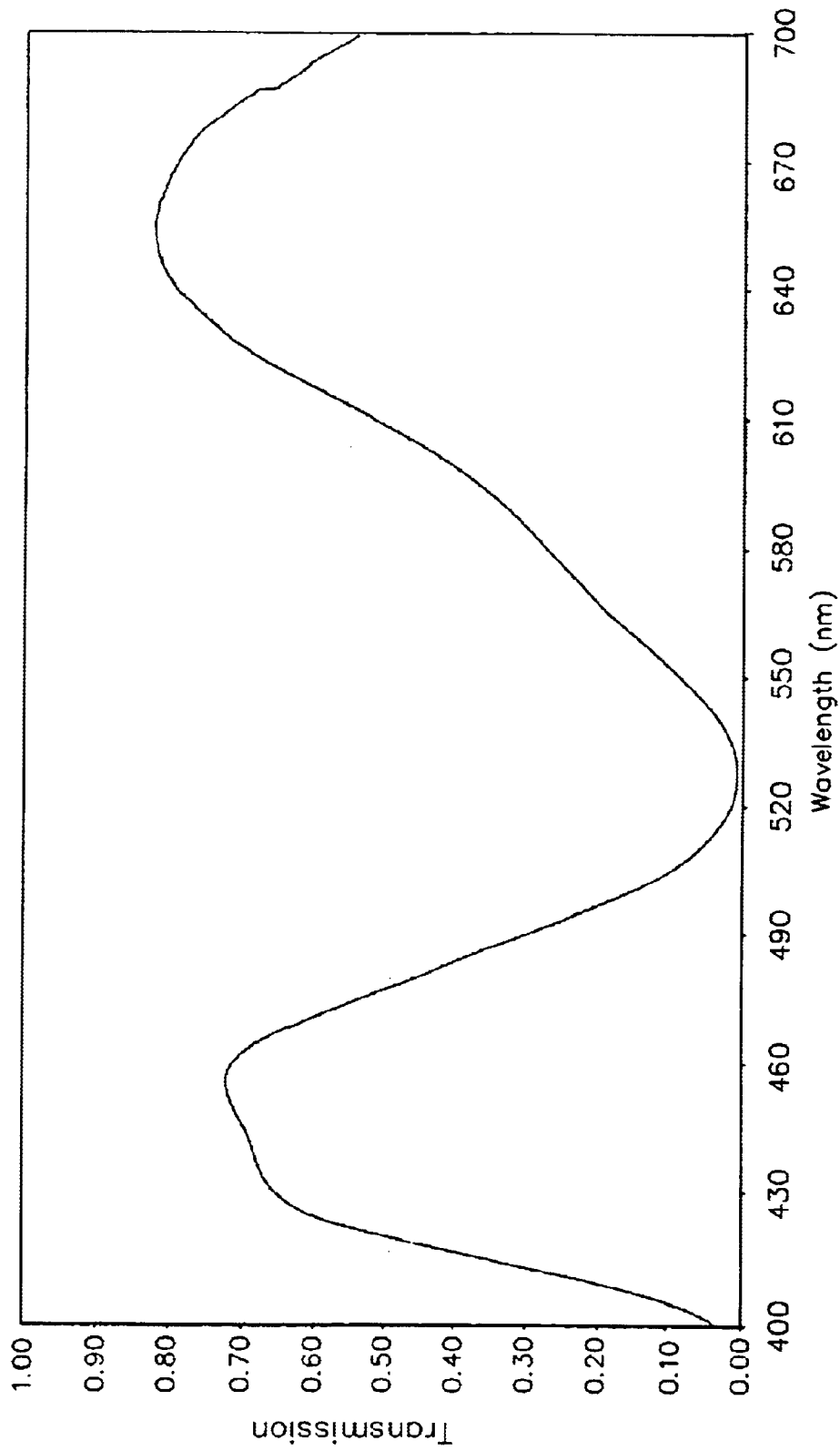

FIG. 21B

CSLM Sequencer - Yellow

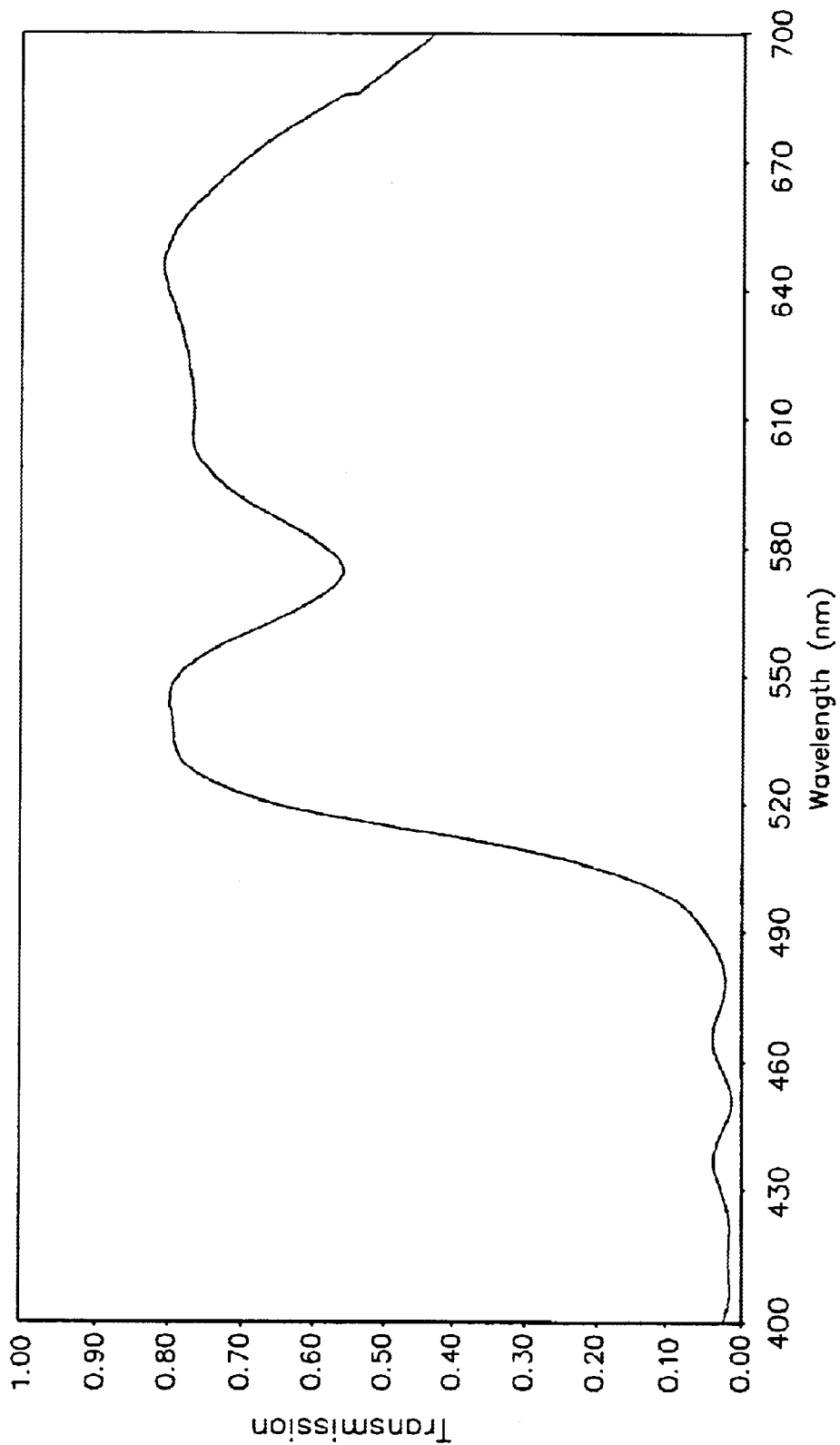

FIG. 21C

Blue/Black Stage

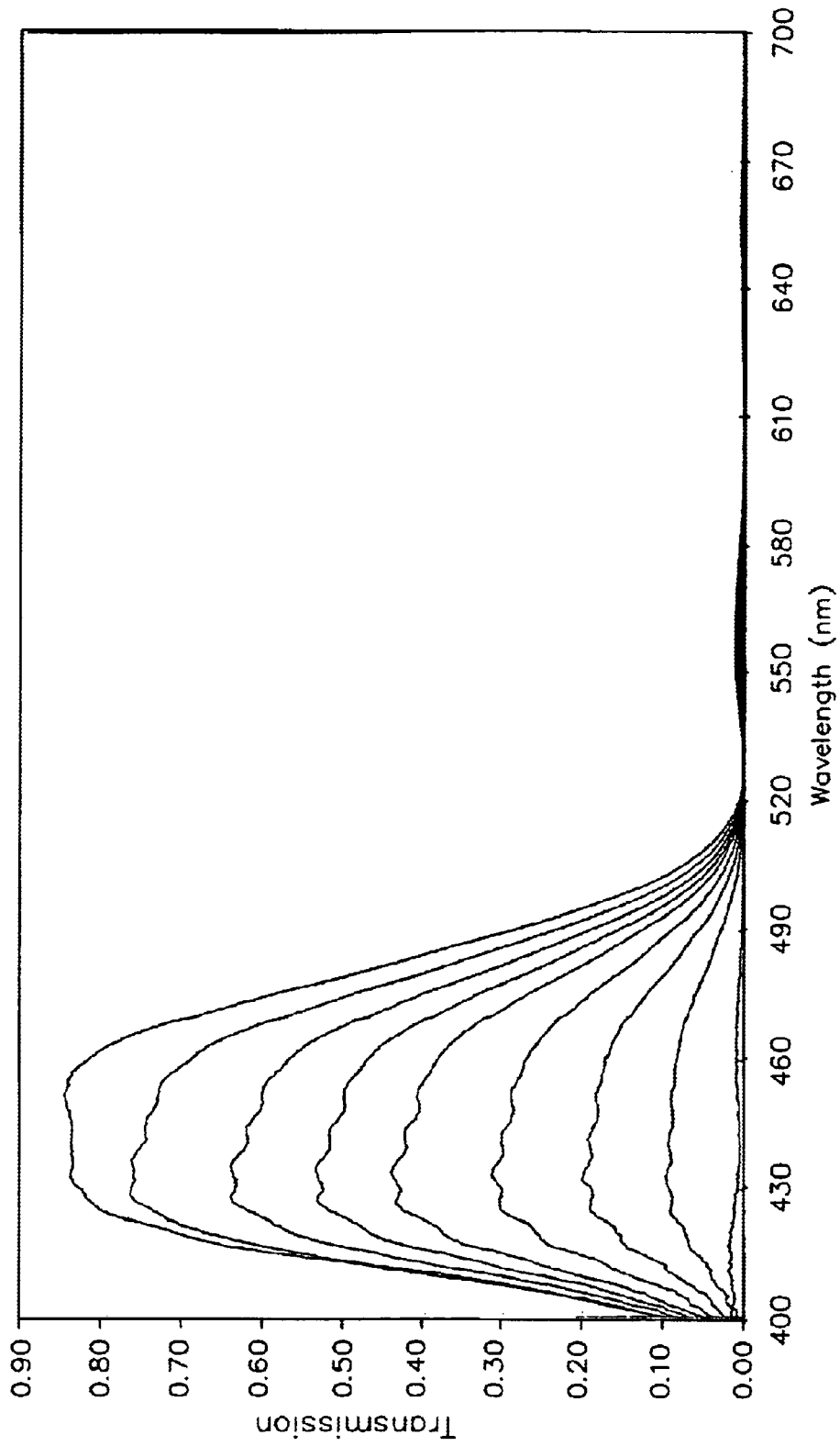

FIG. 22A

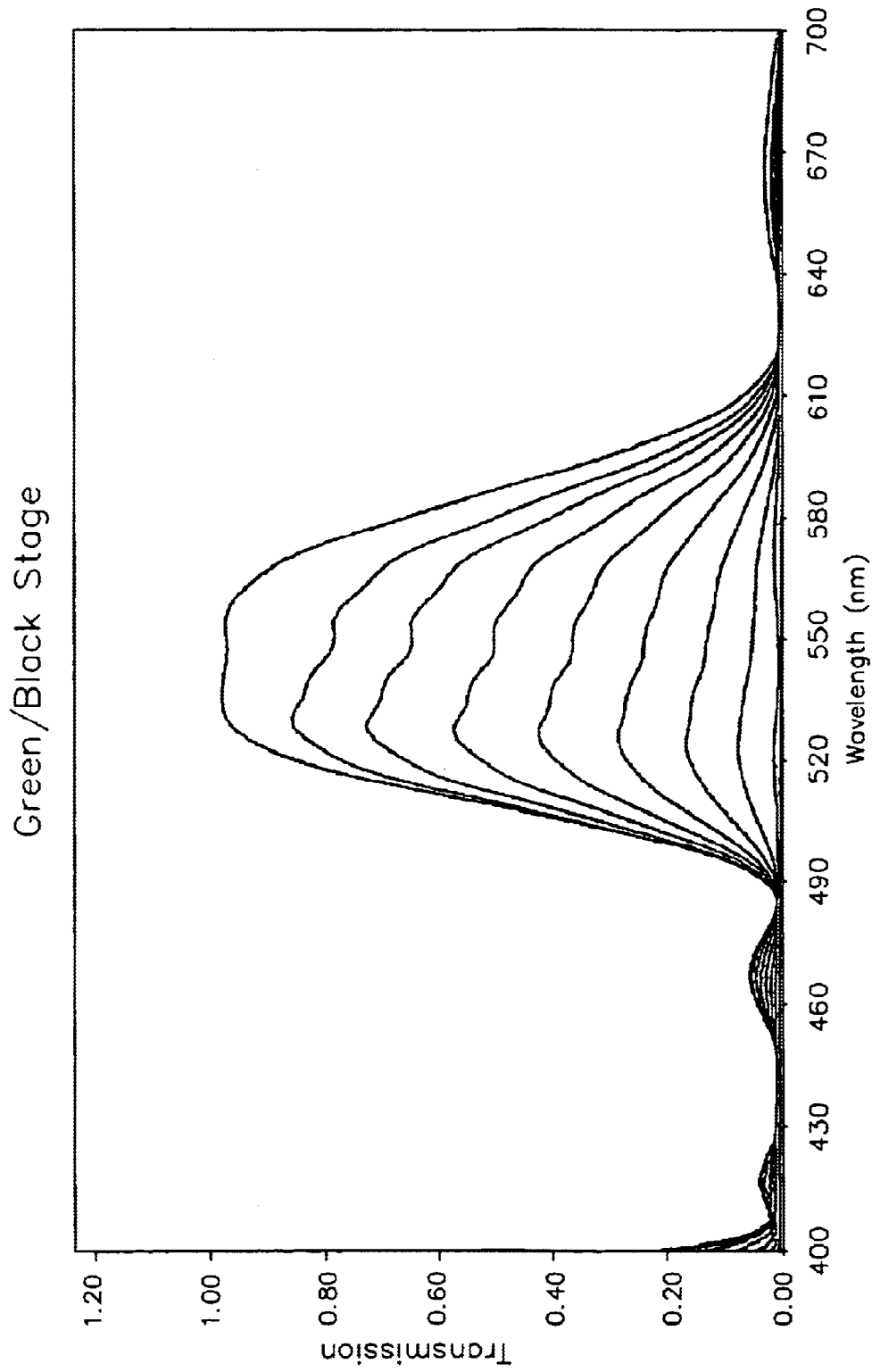

FIG. 22B

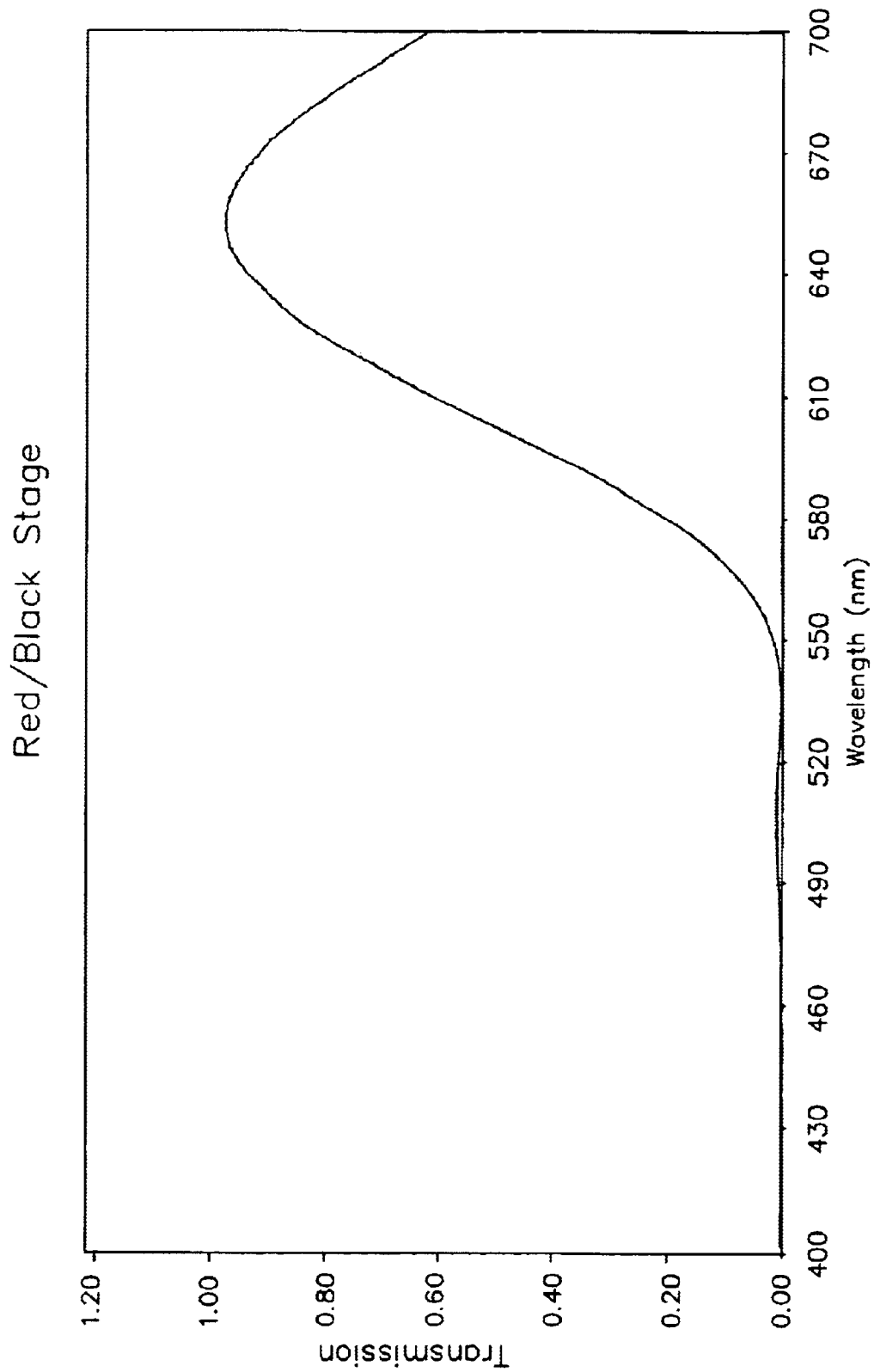

FIG. 22C

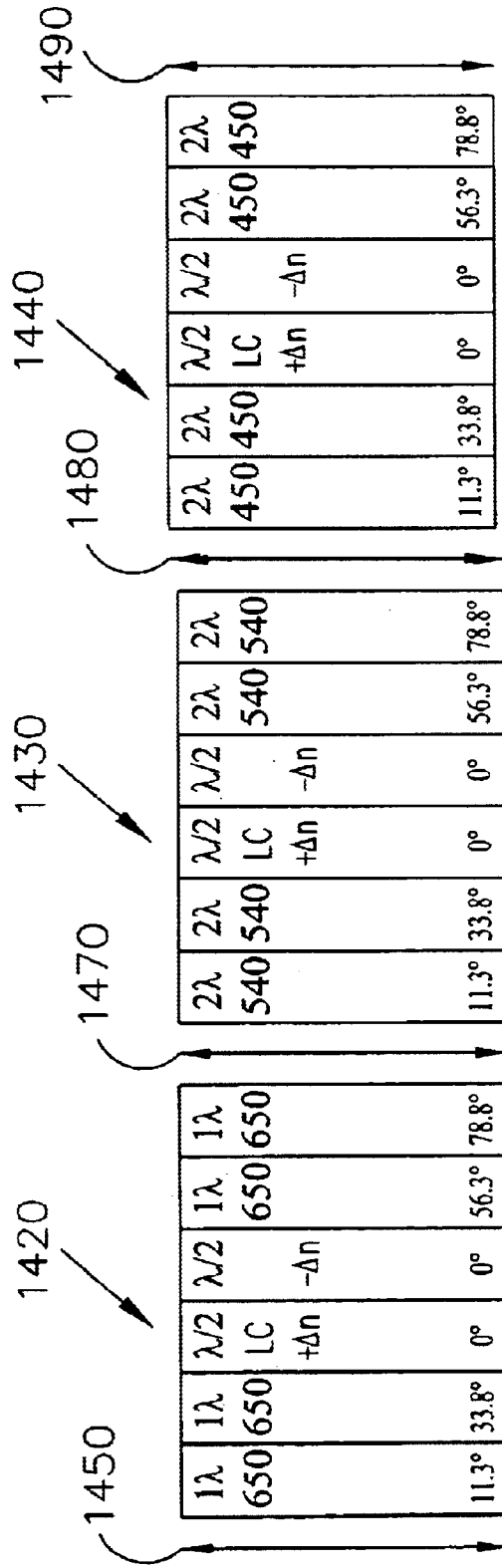

FIG. 23

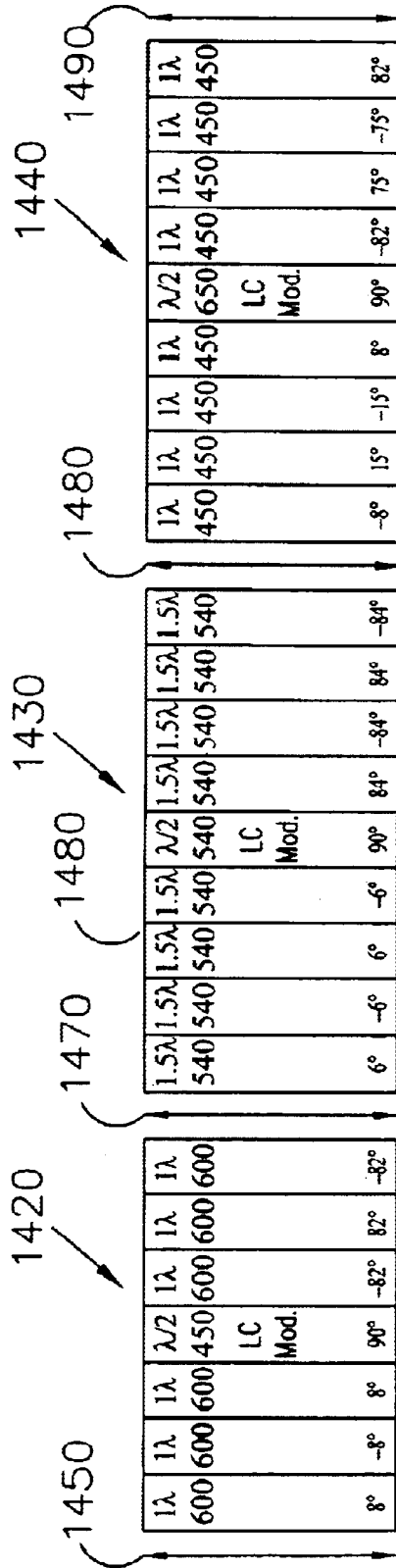

FIG. 24

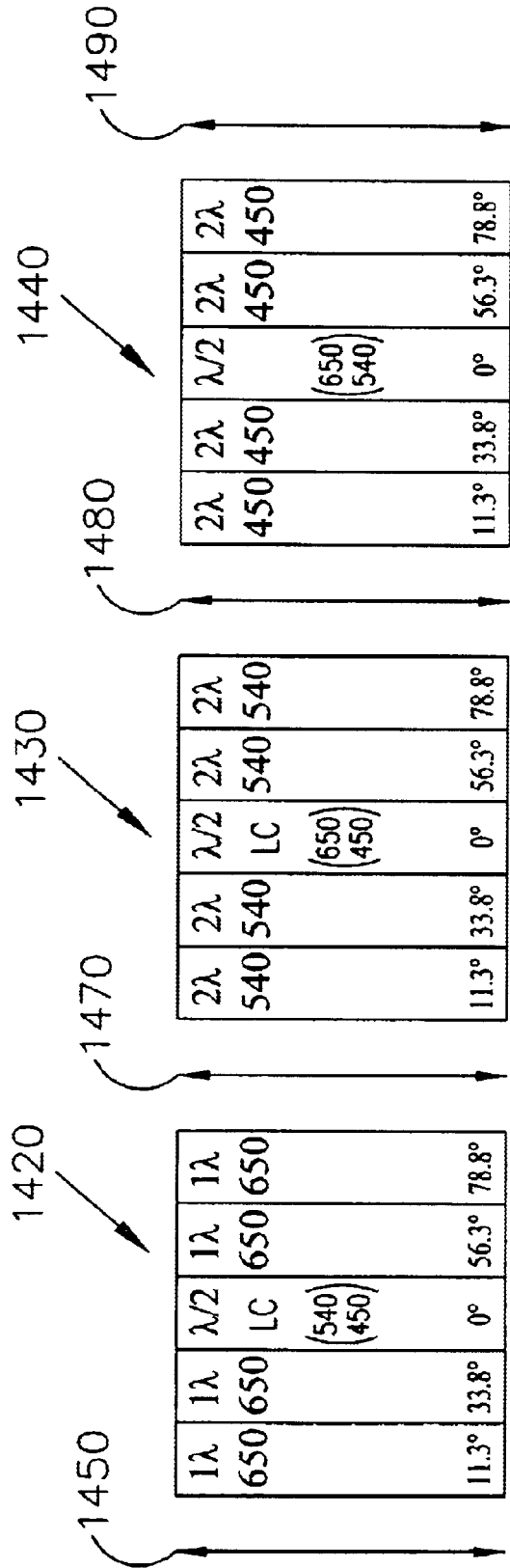

FIG. 25

| Design Number | Number of Panels | Number of Paths | Number of Subframes | Number of Pixels | Display Type   |
|---------------|------------------|-----------------|---------------------|------------------|--|
| 1             | 1                | 1               | 1                   | 3                | R,G,B Color Filter Array   |
| 2             | 1                | 1               | 3                   | 1                | Full-Color Sequential  |
| 3             | 1                | 1               | 2                   | 2                | Hybrid Spatial/Sequential  |
| 4             | 2                | 1               | 1                   | 2                | Hybrid Common-Path/Spatial   |
| 5             | 2                | 1               | 2                   | 1                | Hybrid Common-Path/Sequential  |
| 6             | 2                | 2               | 1,2                 | 1                | Hybrid Sequential/Two-Path (i.e. Path 1: B/G, Path 2: R)   |
| 7             | 2                | 2               | 2,2                 | 1                | Hybrid Sequential/Two-Path (i.e. Path 1: B/R, Path 2: G/R)   |
| 8             | 2                | 2               | 1,3                 | 1                | Path 1: Full Color Sequential (Chrominance Path)<br>Path 2: Monochrome (Luminance Path)                      |
| 9             | 2                | 2               | 1                   | 1,2              | Hybrid Spatial/Two-Path (i.e. Path 1: B/G Pixels, Path 2: R)   |
| 10            | 2                | 2               | 1                   | 1,3              | Path 1: R,G,B Color Filter Array (Chrominance Path)<br>Path 2: Monochrome (Luminance Path)                   |
| 11            | 3                | 1               | 1                   | 1                | Full-Color Common-Path (i.e. Subtractive)  |
| 12            | 3                | 2               | 1                   | 1                | Hybrid Common-Path/Split-Path (i.e. Path 1: B & G Panels, Path 2: R Panel)                                   |
| 13            | 3                | 3               | 1                   | 1                | Conventional Three Panel   |
| 14            | 4                | 1               | 1                   | 1                | Full-Color Common-Path with Black Panel  |
| 15            | 4                | 2               | 1                   | 1                | Path 1: Full-Color Common-Path (Chrominance Path)<br>Path 2: Monochrome (Luminance Path)                     |
| 16            | 4                | 2               | 1                   | 1                | Path 1: Two-Color Common-Path (i.e. B & R Panels)<br>Path 2: Two-Color Common-Path (i.e. G & R Panels)       |
| 17            | 4                | 3               | 1                   | 1                | Path 1: Two-Color Common-Path (i.e. B & R Panels)<br>Paths 2, 3: Conventional Split-Path (i.e. G & R Panels) |
| 18            | 4                | 4               | 1                   | 1                | Paths 1, 2, 3: Conventional Three Panel (Chrominance Path)<br>Path 4: Monochrome (Luminance Path)            |

FIG. 26

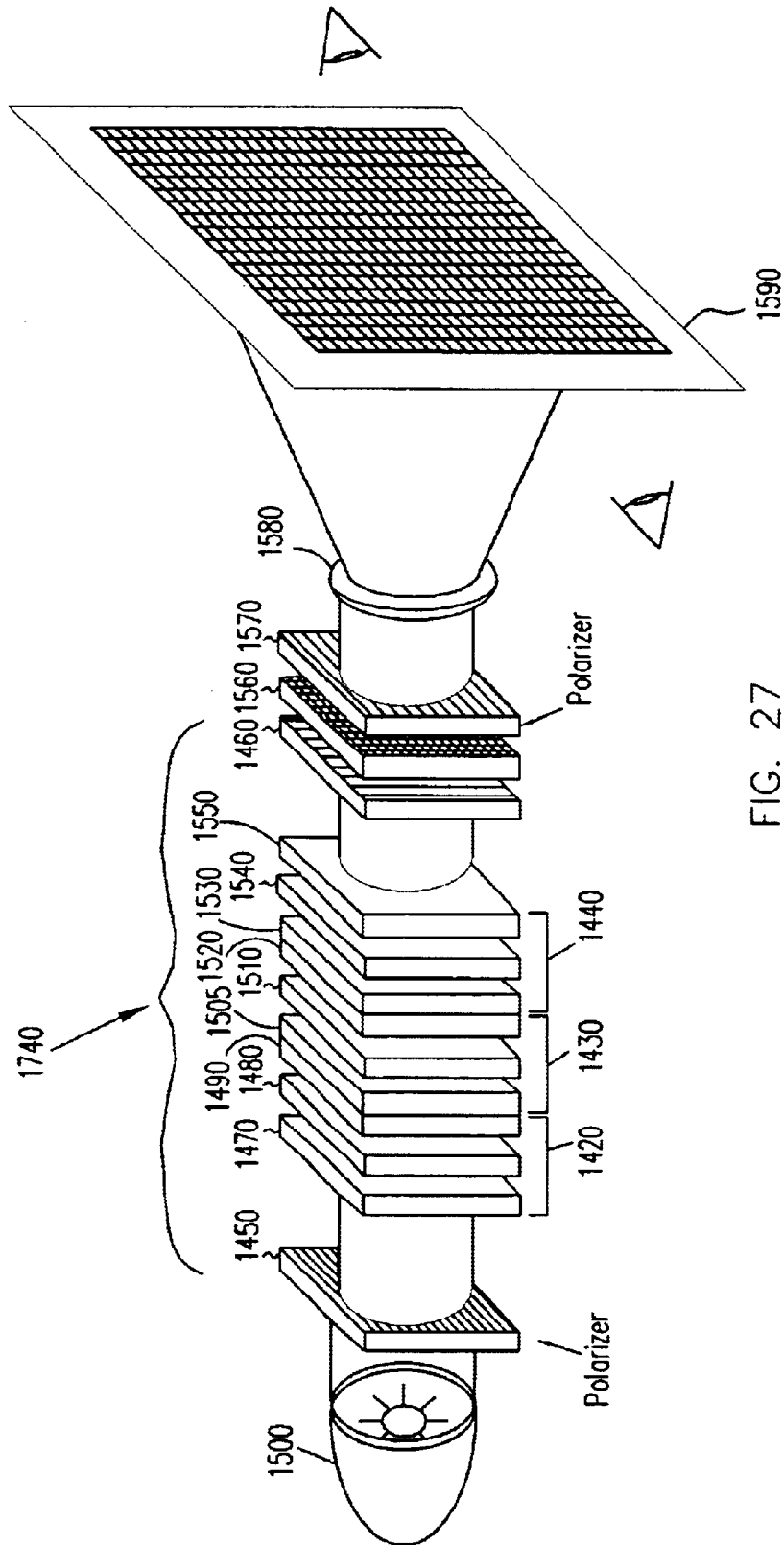
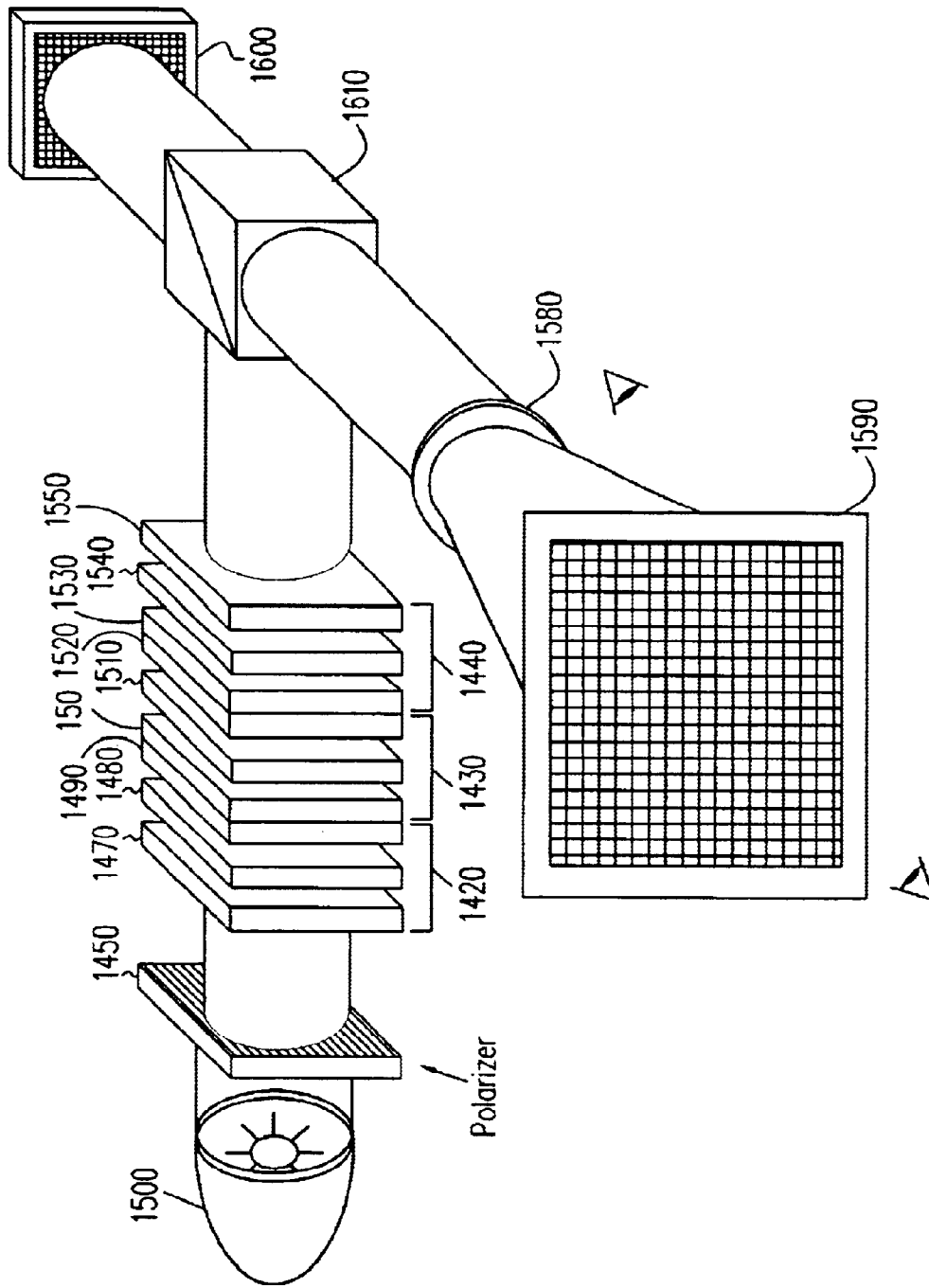

FIG. 27



## COLOR FILTERS AND SEQUENCERS USING COLOR SELECTIVE LIGHT MODULATORS

This application is a Continuation-In-Part application of Ser. No. 08/645,580, filed May 14, 1996 now U.S. Pat. No. 5,822,021, the contents of which are incorporated herein by reference in their entirety.

### BACKGROUND OF THE INVENTION

#### 1. Field of the Invention

This invention relates generally to color selective polarization modulation and, more specifically, to color sequencers for coloring imaging devices, such as displays and cameras.

#### 2. Background of the Related Art

Full color display is generally implemented using one of four techniques: (1) spatially using color filter arrays; (2) temporally using sequential color techniques; (3) additive superposition using multiple optical paths; or (4) subtractively using stacked display panels. In spatial color systems, each full-color pixel is subdivided into at least three sub-pixels, one dedicated to each additive primary color. A color filter array (CFA), consisting of red, green and blue spectral filters, is registered to the active pixel elements of a liquid crystal display (LCD) such that the transmission level of each primary color can be locally controlled. This technique requires that the sub-pixels be sufficiently small that they are not individually resolvable by the viewer. The resulting spatial integration by the eye yields a perceived full-color image. As a result of sub-dividing, display panels used in spatial color systems require three times the number of pixels than those used in monochrome displays.

In sequential color techniques, sub-frames are displayed, with each sub-frame comprising the distribution of an additive primary color in a full-color-image. By displaying the sub-frames at a sufficient rate, e.g., three-times the video rate, or 180 Hz, the eye integrates the sub-frames temporally, yielding a perceived full-color image. In this case, each pixel provides full-color because there is no spatial subdivision. In principle, a full-color pixel using a CFA provides the same brightness as a sequential pixel of the same area. However, neither makes efficient use of light, because displaying an additive primary color generally means blocking the complementary subtractive primary.

To implement a full-color display using additive superposition, as for example in a projection system, the light source is split into three optical paths, each containing the light source power in one additive primary band. Typically, dichroic beamsplitters are used to separate the three additive primary colors into three physically separate paths. One display panel is devoted to spatially modulating the optical transmission in each optical path. Subsequently, each image is additively superimposed to form a full color image. Though this technique is more hardware intensive, it is in principle three times brighter than either spatial or temporal color techniques. As such, it is the preferred technique for implementing projection systems.

In a subtractive display, three optical paths are effectively created without wavefront shearing. The term subtractive is appropriate because such systems are analogous to color film. Though all light travels the same physical path, only specific layers of the structure manipulate light in each wavelength band. In practice, a full-color display consists of a stack of three co-registered transmissive display panels, each responsible for independently determining the local transmission of one additive primary. Because there is only

one physical path, each stage must be made independent of the others using wavelength selective polarization effects. Luminance modulation requires both a polarized input and an effective voltage-controlled analyzing polarizer. Thus, color independent luminance modulation is typically achieved by wavelength selectively controlling the degree of input polarization, and/or the wavelength selectivity of the analyzer. Compared to additive split-path displays, subtractive displays have unique design challenges. In order to obtain high optical throughput, panel transmission losses must be low, any passive color control elements must be low loss, and images must be efficiently relayed between panels. In direct view display systems, there are additional complications associated with color quality and parallax the when the display is viewed off-normal.

There are several subtractive display schemes disclosed in the related art. The simplest structures, such as those disclosed in U.S. Pat. Nos. 3,703,329 and 5,032,007, uses three guest host LCDs with a neutral polarizer. Each LCD panel contains a dye that acts as a color selective polarizer with in-plane projection determined by the applied voltage. In other embodiments, the function of modulation and wavelength selective polarization analysis is decoupled by combining quasi neutral LCDs with color selective polarizing films. Such polarizers can be pleochroic dye polarizers, such as those disclosed in U.S. Pat. No. 4,416,514, U.S. Pat. No. 5,122,887, and K. R. Sarma et al., SID '93 DIGEST, p. 1005, or cholesteric LC films, such as those disclosed in U.S. Pat. No. 5,686,961. Other potential color polarizer film technologies include multi-layer stretched polymer films that behave as dielectric mirrors in one linear polarization, and are isotropic in the orthogonal polarization, such as those disclosed in U.S. Pat. No. 5,612,820, and coated prismatic films, such as those disclosed in U.S. Pat. No. 5,422,756. In still other configurations, such as the configuration disclosed in U.S. Pat. No. 5,050,965, mixed-mode subtractive displays are disclosed that utilize color selective polarizers in combination with birefringence color from twisted LCD panels.

Performance of related art subtractive displays has been hampered by a number of factors. For instance, color quality and throughput are poor due to the shallow transition slope and low peak transmission of many dye polarizers. More fundamentally, the optical density of the black state is typically poor when using three subtractive filter stages.

In a subtractive mode, each additive primary is generated via the cooperative action of two stages, each blocking one additive primary. When the blocked additive primaries are adjacent primaries, there is typically an unwanted leakage. More significantly, a dense black state is obtained by subtracting all three additive primaries from white, including any interprimary light. This represents a difficult spectral management problem, because contrast ratios can plummet with even small side lobe amplitudes. Furthermore, designs that achieve acceptable contrast are frequently not robust against small fabrication tolerances, variations in modulator uniformity, and environmental changes. This is because high contrast ratio demands a high level of cooperation between stages.

Reduced side lobe levels can be obtained by increasing the overlap of each subtractive primary. However, this cannot be done without adversely affecting the color coordinates of the primary colors. While passive notch filtering can be provided to eliminate interprimary light, there is an associated insertion loss and an increase in cost. As in printing systems, a fourth "black-panel" can be inserted to improve contrast ratio, which again increases cost and complexity and reduces throughput. This "black-panel" technique is disclosed in U.S. Pat. No. 5,050,965.

Tunable filters or color shutters are well documented in the prior art. There are two classes of such filters: polarization interference filters (PIFs), and switched polarizer filters (SPFs).

PIFs have traditionally been used for spectrometry instrumentation, because they are bulky, complex to fabricate, and require calibration. Lyot PIFs consist of stand-alone filter units acting cooperatively to generate a bandpass profile. Such spectral profiles are not considered ideal for display, particularly in the blue, where adequate red blocking determines an unnecessarily narrow bandpass width. Tuning Lyot PIFs typically requires inserting analog LC devices in each stage and forming a look-up table.

The Solc PIF has the benefit that internal polarizers are eliminated, as do other filters designed using finite impulse response methods (Harris, Ahmann, and Chang). In general, however, tuning the profile of a PIF requires shifting the center wavelength of each retarder in unison. Therefore, each passive retarder must be made active with the addition of one or more LC devices. Such structures enable the generation of analog true-color, which is beneficial in spectroscopic applications. In color Display/Imaging, however, higher throughput and simpler structures are achieved using SPFs.

An SPF utilizes a digital LC switch to toggle between orthogonal polarization states. A passive component, or color polarizer, has substantially different transmission spectra associated with these polarizations. Thus, driving the LC device between states provides modulation between the two color polarizer spectra. Should the LC device be driven in an analog mode, the output typically consists of voltage-controlled mixtures of the color polarizer spectra.

Color polarizers used previously in SPFs include single (45°-oriented linear retarders on neutral polarizers (disclosed in U.S. Pat. No. 4,003,081 to Hilsun, U.S. Pat. No. 4,091,808 to Scheffer, and U.S. Pat. No. 4,232,948 to Shanks), pleochroic dye linear polarizers (disclosed in U.S. Pat. No. 4,582,396 to Bos, U.S. Pat. No. 4,416,514 to Plummer, U.S. Pat. No. 4,758,818 to Vatne, and U.S. Pat. No. 5,347,378 to Handschy), hybrid structures containing both effects (disclosed in U.S. Pat. No. 4,917,465 to Conner, and U.S. Pat. No. 5,689,317 to Miller), cholesteric liquid crystal circular polarizers (disclosed in U.S. Pat. No. 5,686,931 to Funfschilling et al.), and polarizer retarder stack (PRS) technology (disclosed in U.S. Pat. No. 5,751,384 to Sharp). Other potential color polarizer technologies include coated prismatic polarizers (disclosed in U.S. Pat. No. 5,422,756 to Weber), and multi-layer stretched polymers (disclosed in PCT Application No. WO 95/17691 to Ouderkerk).

The highest throughput SPFs currently utilize PRS technology. Because such structures use a switch external to the stack, conservation of power dictates that, assuming a neutral switch, the two spectra are substantially inverses of one another. In the absence of additional passive filtering, the spectra are highly related, with a spectral overlap at the half-maximum point. As such, retarder based SPF technology is well suited to switching between complementary colors, rather than switching between filtered and neutral outputs.

Another issue with complementary color switch technology concerns the robustness of the output. Typically, cell chrominance has a significant influence on the resulting color coordinate. While the center wavelength and uniformity of the cell are determined in fabrication, behavior is subsequently influenced by temperature, voltage, incidence

angle and azimuth. For instance, when a zero twist nematic (ZTN) cell inverts the spectrum of a PRS (typically the undriven state), the half-maximum point can be shifted according to the half-wave retardance of the cell. In the driven state, the cell can be made to vanish at normal incidence, giving color polarizer limited performance. However, a significant retardance is typically experienced when viewing the filter off-normal, which can significantly influence the color coordinate. Thus, achieving a stable color coordinate using complementary switching can place impractical tolerances and, in some cases, demand unattainable performance on the cell.

#### SUMMARY OF THE INVENTION

The present invention provides color selective light modulation, and color filters and sequencers utilizing the same. Color separation is accomplished with nearly lossless retarder films, providing high spectral contrast between transmission and extinction, with arbitrarily steep transition slopes.

In the color filters and color sequencers of the present invention, each color filter stage is a color selective light modulator (CSLM) which varies the transmission of one color without modulating the complementary color. A color filter stage can switch between transmitting a neutral spectrum (white or black) and transmitting a chromatically filtered spectrum. Two or more color filter stages can be used in series, with each filter stage independently controlling the transmission of a primary color.

In a preferred embodiment, each filter stage controls the transmission of an additive primary color locally in an analog fashion, thus integrating image and color generation. One preferred embodiment eliminates internal polarizers between filter stages, thereby providing a full-color display with only an input polarizing means and an output polarizing means. A preferred two-polarizer configuration operates in an additive mode, which exhibits benefits over subtractive mode schemes.

Color selective light modulators (CSLM) contains an active polarization modulating element (modulator), e.g., an electro-optic or magneto-optic polarization modulator having a modulation state of polarization which is substantially intermediate between isotropic states of polarization, i.e., eigenpolarizations. The CSLM further comprises a retarder stack comprising one or more retarders.

The modulation state of polarization is an input polarization for which the transmitted state of polarization depends on the voltage applied to the modulator. The isotropic state of polarization is an input polarization for which the transmitted state of polarization is substantially independent of the voltage applied to the modulator. The retarder stack chromatically preconditions the light such that a first spectrum is placed in the modulation state of the modulator and a second complementary spectrum is placed in the isotropic state of the modulator. Thus, the modulator modulates the SOP of the first spectrum, but leaves the polarization of the complementary spectrum substantially unmodulated. In a preferred embodiment, the spectra are additive and subtractive primary spectra.

A CSLM, which forms a color filter, is formed by combining the retarder stack and the modulator with a polarization analyzer. The polarization analyzer can be a second retarder stack in combination with a neutral polarizer, or it can be a color selective polarizer, such as a linear or circular color polarizing filter. Examples of these types of color selective polarizers are pleochroic dye polarizers, cholesteric liquid crystals, and cholesteric liquid crystal polymers.

5

In a preferred embodiment, the polarization analyzer comprises a second retarder stack positioned between the modulator and an analyzing polarizer. Such structures have the potential of providing complete transmission, or complete blocking, of an unmodulated spectrum, while permitting 100% luminance modulation of the complementary spectrum. The relationships between retarder stacks (i.e. number, orientation and retardation of each retarder film) significantly influences the overall behavior. Exemplary retarder stack relationships represent cooperative polarization transformations, yielding full luminance modulation of a well-defined spectral band, with zero modulation of the complementary spectral band.

In a color filter containing two retarder stacks, the polarizers and retarder stacks can be oriented so that the color filter is either stack only (SO) neutral, i.e., transmits white light in the absence of the modulator, or SO filtered. In the SO neutral mode, the action of the modulator is to produce a filtered output, while the SO filtered mode uses the modulator to generate the neutral state. In either case, the voltage applied to the modulator effectively controls the "presence" of the compound retarder stack, i.e., the extent to which the two retarder stacks cooperate in filtering rather than canceling to produce a neutral output. If the modulator is capable of analog modulation, the voltage controlled presence of the compound retarder stack is also analog.

In addition to the retarder stacks, additional polarization transforming elements can be included between the input and exit polarizers in order to, for example, resolve compatibility issues between the polarizers and the type of modulator. For polarized light sources, no input polarizer is required. In embodiments having no internal polarizers, the color filters can be operated in split path configurations having polarization separators/combiners for the input and exit polarizers. The color filters can also employ reflection-mode designs.

Unlike common paths displays and color sequences of the prior art, a two-polarizer CSLM permits operation in an additive mode rather than a subtractive mode, by eliminating the need to analyze the state of polarization after each stage. This eliminates the interaction of filter stages on a power basis. Inverting the spectra, such that additive primaries become subtractive primaries, white becomes black, and vice-versa, yields important performance improvements. Specifically, the filter stages become independent in generating additive primaries, while a high density black state can be achieved. This is accomplished with little impact on the subtractive primaries and the white state.

The CSLM of the present invention contains the active polarization modulating element within the retarder stack, rather than adjacent to the retarder stack, thus providing modulation between a filtered spectrum and a neutral spectrum. It is an object of this invention to provide high throughput color filters with outputs arbitrarily selectable from the set of R,G,B,C,M,Y,W, and K (black). It is a further object of this invention to produce multi-stage color filters and sequencers that contain no internal analyzing polarizers. It is yet a further object of this invention to produce color filters with fixed color coordinates which do not rely upon accurate active polarization modulating element characteristics. It is also an object of this invention to integrate such filters with displays and digital cameras to yield high performance color generation, with or without neutral outputs.

In accordance with the present invention, a common-path stacked-panel projector is operated in an additive mode, rather than a subtractive mode. This unique option is enabled

6

by color selective light modulators (CSLMs), which permit one to avoid any light blocking until after light passes through all three panels.

Additional advantages, objects, and features of the invention will be set forth in part in the description which follows and in part will become apparent to those having ordinary skill in the art upon examination of the following or may be learned from practice of the invention. The objects and advantages of the invention may be realized and attained as particularly pointed out in the appended claims.

#### BRIEF DESCRIPTION OF THE DRAWINGS

The invention will be described in detail with reference to the following drawings in which like reference numerals refer to like elements wherein:

FIG. 1 is a table listing 24 preferred designs of the neutral/primary color filters/switches of the present invention;

FIG. 2 shows a first embodiment of the color selective light modulators of the present invention;

FIG. 3 shows a second embodiment of the color selective light modulators (CSLM) of the present invention;

FIG. 4 shows a third embodiment of the color selective light modulators of the present invention;

FIG. 5 shows a fourth embodiment of the color selective light modulators of the present invention;

FIG. 6 shows a fifth embodiment of the color selective light modulators of the present invention;

FIG. 7 shows a sixth embodiment of the color selective light modulators of the present invention;

FIG. 8 shows a seventh embodiment of the color selective light modulators of the present invention;

FIG. 9 shows a eighth embodiment of the color selective light modulators of the present invention;

FIG. 10 shows a ninth embodiment of the color selective light modulators of the present invention;

FIG. 11 shows a tenth embodiment of the color selective light modulators of the present invention;

FIG. 12 shows a eleventh embodiment of the color selective light modulators of the present invention;

FIG. 13 shows a twelfth embodiment of the color selective light modulators of the present invention;

FIG. 14 is a table that lists color selective light modulator designs with N=3 that have the required symmetry for implementing a reflection mode device (CSLM);

FIGS. 15a, and 15b are plots of the measured output of reflection mode magenta and yellow CSLMs, respectively;

FIG. 16 shows a variable hue (CSLM) that switches between a green output and a magenta output in accordance with the present invention;

FIG. 17a is a block diagram of a two-polarizer multi-stage CSLM in accordance with the present invention;

FIG. 17b is a block diagram of a four-polarizer, three-stage CSLM in accordance with the present invention;

FIG. 18 shows a digital color sequencer that incorporates a two-polarizer additive (SO black) CSLM design in accordance with the present invention;

FIG. 19 is a truth table for the DCS of FIG. 18;

FIGS. 20a, 20b and 20c are plots of the measured red, green and blue transmission spectra, respectively for the fully assembled RGB DCS of FIG. 18;

FIGS. 21a, 21b and 21c are plots of additional measured cyan, magenta and yellow spectra that are also available with the RGB DCS of FIG. 18;

FIG. 23 shows a four-polarizer DCS with SO additive primary stages in accordance with the present invention;

FIG. 24 shows a four-polarizer DCS that generates a SO white state in accordance with the present invention;

FIG. 25 shows a wide field of view four-polarizer RGB-CLSM that utilizes an SO additive primary design in accordance with the present invention;

FIG. 26 is a table listing 18 examples of display types, that can utilize the CSLMs of the present invention;

FIG. 27 shows a full color sequential display implemented with a transmissive liquid crystal display, and utilizing the digital color sequencer of the present invention; and

FIG. 28 shows a full color sequential display using a reflective liquid crystal display, and utilizing the digital color sequencer of the present invention.

#### DETAILED DESCRIPTION OF PREFERRED EMBODIMENTS

Color selective polarization modulators are described in the present invention for use as color selective light modulators (CSLMs). CSLMs are units that color selectively control the transmission of light using active or spatially patterned elements. The color selective elements in the CSLMs are typically stacks of retarder films. However, they can be thin twisted liquid crystal films. Two retarder stacks, which are related in retardation values and orientations, are used to determine the spectral band over which the active element can modulate light transmission. An polarization modulator or a spatially patterned polarization modulator is positioned between the stacks for controlling the transmission of selected spectral bands. If an active modulator is used, the transmission of the selected bands are electronically and temporally controlled. If a spatially patterned modulator is used, the transmission of selected spectral bands are spatially controlled.

Such CSLM devices are useful for common-path color display systems, digital color sequencers, and for analog color generation in applications such as lighting, spectrometry, colorimetry, and multi-spectral imagery.

#### Definitions

A few definitions that are used to characterize the structures of the present invention and their behavior will now be provided. An additive primary color is one that is identifiable as a substantially saturated red (R), green (G) or blue (B) by a viewer with normal color vision. Conversely, colors that are desaturated RGB hues are termed pastels. Colors that are saturated but have other hues can be produced as admixtures of the additive primary colors, i.e., yellow or orange.

The term "subtractive primary color" refers to the absence of one additive primary color. These are known as cyan (C), magenta (M) and yellow (Y), and are the colors used in subtractive systems, i.e., printing systems. Unless otherwise stated, cyan is considered to be blue+green, magenta is considered to be blue+red, and yellow is considered to be green+red. Monochromatic yellow is referred to as true-yellow.

Colors are complementary when the sum of their power spectra gives a true white spectrum, i.e., cyan+red, magenta+green, or yellow+blue. By conservation of power, complementary colors can be generated, for instance, by rotating a neutral analyzing polarizer, following an arbitrary polarizer/retarder stack, through  $(\pi/2)$ .

A "filtered" spectrum is a spectrum that is chromatically altered upon transmission through the filter structure. The

transmitted spectrum has a particular hue, and is significantly more saturated than a "neutral" spectrum discussed below. Preferred filtered spectra are those that represent saturated colors, such as the additive primaries RGB, or the subtractive primaries CMY.

A "neutral" spectrum is one that is not chromatically altered by upon transmission through the filter structure. The transmitted neutral spectrum has coordinates that are substantially nearer the white point of the Commission International DE l'Eclairage diagram than a filtered spectrum. Examples include the white state or the black state of a filter.

An "Eigenpolarization" is a polarization state which is unchanged upon passage through a filter structure.

"Stack-Only" mode refers to the output of a filter structure when the active element is absent, or when the active element is driven to the electrooptic equivalent of being absent. The SO mode can be such that the two retarder stacks work cooperatively to transmit either a neutral spectrum or a filtered spectrum when they are positioned between neutral polarizers.

"Stack-Altered" (SA) Mode refers to the output of a filter structure when the active element is used to effectively alter the "presence" of one stack relative to the other stack. The SA mode can be such that the two stacks work cooperatively to generate either a neutral spectrum or a filtered spectrum when they are positioned between neutral polarizers.

The human eye has a wavelength-dependent sensitivity, being most sensitive to green light during normal daylight illumination conditions. Conversely, the eye is nearly insensitive to short wavelength blue, i.e., less than 400 nm, and long wavelength red light, i.e., greater than 700 nm.

The eye has three discrete photoreceptors that correspond to the three additive primaries. As such, the eye can be "tricked" into observing arbitrary colors using appropriate mixtures of the three additive primaries. This allows for the generation of full-color imagery using only three-color information. The additive primaries are separated by transition bands that are, in principle, not necessary for full color imagery. These transition bands are true cyan, at a wavelength of approximately 500 nm, and true yellow, at a wavelength of approximately 585 nm. In many instances, the transition bands are rejected in order to enlarge the available color space.

The CSLM structures of the present Invention comprise two stacks of retarders, with an active polarization modulator or a spatially patterned polarization modulator between them. The polarization modulator can preferably be driven between two extreme states, preferably in an analog fashion. In a preferred embodiment, the modulator enables the SO mode in one extreme state, and enables the SA mode in the other extreme state.

If a spatially patterned modulator is used between the two retarder stacks, the spatially patterned modulator is preferably patterned so that the SO mode is enabled when light passes through one portion of the patterned modulator, and the SA mode is enabled when light passes through another portion of the patterned modulator. In addition, one or more additional portions of the modulator may be patterned to enable additional intermediate modes, i.e., modes that lie in between the SO mode and the SA mode.

In the SA mode, the output observed between neutral polarizers is the result of the cooperative effects of the retarder stacks, in conjunction with the effect of the modulator. In effect, the modulator modifies the presence of one retarder stack relative to the other, thereby modifying the characteristics of the both retarder stacks together. The SA

mode is associated with an extreme modification of the both retarder stacks relative to the SO output. However, it should be recognized that analog states can exist between the SO and SA modes. The above discussion applies to all the filter structures described herein.

#### Characteristics of the Modulator

The methodology for designing individual retarder stacks, as well as the relationships between retarder stacks, depends upon the characteristics of the polarization modulator (modulator) used in the CSLM. Modulators can include, but one not limited to, mechanical, electromechanical, liquid crystal, linear electrooptic effect, magneto-optic, and non-linear electrooptic effect devices. Modulators can be addressed electrically, optically, or using hybrid effects via media that generate photo currents.

Liquid crystal (LC) based modulators are preferred due to their low manufacturing costs, their scalability, their ability to impart large polarization transformations per unit interaction length, their ability to impart large modulation with low voltage/power, and other considerations. LC devices generally fall under the following categories: (1) Zero-Twist Nematic (ZTN) or Electrically Controlled Birefringence (ECB) devices; (2) Twisted Nematic Devices; and (3) In-Plane Switching Devices.

ZTN or ECB devices are a subset of LC devices in which the in-plane retardation is controlled by an electric field applied normal to the plane. ZTN or ECB devices include anti-parallel nematic devices, pi-cell or surface mode devices, vertically aligned nematic (VAN) devices, and hybrid aligned nematic (HAN) devices.

Anti-parallel nematic devices and pi-cell or surface mode devices have maximum retardation in the undriven state and are nearly isotropic in the driven state. High contrast is often obtained by adding external compensation in order to eliminate residual retardation in the driven state.

VAN devices are homeotypically aligned on both substrate surfaces. They are isotropic in the undriven state, with an increasing in-plane retardation with applied voltage. VAN devices have very little residual retardation and hence give high contrast with no external compensation.

HAN devices are homeotypically aligned on one substrate surface, and planar aligned on the other substrate surface.

A Twisted Nematic device is one in which the substrates are rubbed other than parallel or antiparallel. Twisted Nematic devices with a difference in rub angle of approximately  $45^{\circ}$ – $90^{\circ}$  are typically called "TN" devices, while devices with a difference in rub angle of approximately  $240^{\circ}$ – $270^{\circ}$  are typically called "STN" super-twist nematic devices. TN devices are typically addressed using transmissive active matrix thin film-transistor (TFT) panels. STN devices can be highly multiplexed, permitting passive matrix addressing schemes. Small twist angles ( $40^{\circ}$ – $60^{\circ}$ ) are often used for mixed-mode reflective displays.

An In-Plane Switching device refers to any switch in which the molecular directors rotate substantially in the substrate plane. Examples include chiral smectic devices, e.g., ferroelectric LC or electroclinic LC devices, surface-stabilized chiral smectic C, volume-stabilized smectic C, distorted helix ferroelectric, flexoelectric, achiral smectic, and anti-ferroelectric LC devices. There are also In-Plane Switching nematic devices which are driven by lateral electrodes. That is, if lateral electrodes on one of the device substrates are used rather than transparent electrodes deposited on opposing device substrates, nematic liquid crystals can operate as rotatable retarders with fixed retardance.

Compound retarders utilizing a liquid crystal active retarder in combination with one or more passive retarders can be used as the modulator in the CSLM. Particularly useful are achromatic compound retarders, as described in U.S. patent application Ser. No. 08/419,593, and achromatic polarization rotators, as described in U.S. patent application Ser. No. 08/549,963, both of which are incorporated by reference in their entirety herein.

The achromatic compound retarder comprises a liquid crystal rotatable half-wave retarder flanked by passive retarders, wherein the orientations and retardances of the passive retarders are such that the compound retarder is achromatic. The achromatic polarization rotator comprises a liquid crystal rotatable half-wave retarder in combination with a passive half-wave retarder. In the optically compensated bend (OCB) cell, a pi-cell is combined with a retarder film that has a z-direction retardance to improve field-of-view. STN displays frequently use one or more retarder films to suppress birefringence color that is otherwise observed. Both TN and STN displays use retarder films to improve contrast ratio and to improve the view angle.

Typically, the behavior of LC devices is interferometric in nature. Specifically, there are two orthogonally polarized eigenpolarizations with a voltage-controlled phase shift between them. The phase difference introduced between waves, i.e., the retardation, results in a change in the state of polarization (SOP). ZTN devices are very simple, because the eigenpolarizations are well defined and are both independent of voltage and wavelength. Though more complex, twisted nematic devices also have eigenpolarizations. The specific designs presented herein are optimized for ZTN modulators, though it should be appreciated that retarder stacks can be designed and generated for use with twisted nematic devices.

Optically active devices are another group of electro-optic modulators that can be used as the modulator in the CSLMs of the present invention. Optically active devices are polarization rotators, with the polarization rotation being independent of the polarization orientation of the incident light. The isotropic states are left-handed and right-handed circular polarizations. The optically active modulator performs voltage-controlled phase shifting of the circular polarizations, which does not affect the circular state of polarization. However, for linear states, which can be decomposed into equal amplitudes of the left-handed and right-handed circular polarizations, the transmitted polarization is linear and the orientation is determined by the phase shift between the circular states. Thus, optically active modulators act as polarization rotators for linear states, with the modulation state of polarization being any linear state.

Chiral Smectic Liquid Crystal (CSLC) retarders reflect polarization about an axis rather than rotating the polarization. However, they are like optically active devices in their isotropic and modulation states of polarization. In contrast to zero-twist nematics, CSLCs rotate in-plane, having a fixed retardance and an optic axis orientation that is determined by the applied voltage. For a half-wave retardance, CSLC retarders have circular isotropic states and linear modulation states. The voltage-controlled orientation of the optic axis in the CSLC retarder determines the transmitted orientation of linear light.

There are also electro-optic modulators that have intermediate modulation and isotropic states, such as twisted nematic devices. The polarization transformation of a twisted nematic device is most easily seen on the Poincare sphere (G. E. Bigelow and R. A. Kashnow). The State of

Polarization follows a cone rolling on the equator, with a base radius that depends, in part, on wavelength. As the pitch, which is four times the cell gap for 90-degree TN, and birefringence become large, the base of the cone becomes small and almost independent of wavelength, and the device appears optically active, i.e., it exhibits circular Eigenpolarizations. For lower pitch values, a linear state introduced along the rub direction, i.e., normal direction, performs excursions from the equator. These excursions represent periodic introduction of ellipticity coupled with the dominant rotation. Light introduced along the rub direction with the appropriate ellipticity maintains that ellipticity during rotation. This wavelength-dependent elliptical state experiences a pure rotation. This construction can also be used to describe the transformation of an STN device in the undriven state.

It was recently shown experimentally that a twisted nematic device is an elliptical retarder with elliptical Eigenpolarization states. Like the linear variable retarder, the phase shift is substantially determined by one particular helicity of polarization state. This is described in J. L. Pezzaniti and R. A. Chipman, "Phase-only modulation of a twisted nematic liquid-crystal TV by use of the eigenpolarization states," *Opt. Lett.* 18, 1567-1569 (1993).

To achieve compatibility between the retarder stacks and the modulator, passive retarders can be included in the CSLM. For example, if the retarder stacks prepare the light in two linear polarizations separated by 45° C., these polarization states are the modulation and isotropic states of polarization for a modulator that comprises a variable retarder with fixed orientation. A passive quarter-wave retarder oriented parallel to one of the polarization states converts the two linear polarizations into one linear and one circular polarization, which are the modulation and isotropic states of polarization for a modulator that comprises a rotatable retarder with fixed retardance. Thus, if the CSLM includes a passive quarter-wave retarder on either side of a modulator that comprises a CSLC retarder, retarder stacks designed for a variable retarder can instead be used with a rotatable retarder.

#### General Considerations

Without using specific retarder stack designs, an analysis of filter designs can be performed subject to the following assumptions: (1) it is desirable to generate either black or white in the neutral state of a color filter/switch; (2) it is desirable to generate "stable" primary colors (nominally from the set RGBCMY) in the filtered state of the color filter/switch. That is, it is desirable for the chrominance of the modulator, e.g., an LC cell, to have little influence on the filter color coordinate; (3) the CSLM is designed so that the modulator optically "vanishes" in the SO mode throughout the visible spectrum; and; (4) the modulator exhibits some chrominance in the SA mode, such that it cannot adequately maintain a constant polarization transformation throughout approximately two-thirds of the visible spectrum. With those assumptions, various general color filter configurations can be analyzed. It should be noted that there may be applications for which the above assumptions are not relevant.

FIG. 1 is a table listing 24 preferred designs of neutral/primary color filters/switches, based on a choice between six additive and subtractive primary filtered states, white or black neutral states, and stack-only (SO) or stack-altered (SA) states. In general, the SO output is of higher quality, because it is generally more practical to achieve a neutral isotropic state with a nematic LC device than an achromatic

retardation (or rotation) state. While it is possible to fabricate achromatic LC devices for the SA mode, e.g., thick TN structures, we assume that the SO state is superior to the SA state.

If an LC cell is used as the modulator one of the most significant differentiators when comparing color filter/switch designs is the impact of the LC cell chrominance on the quality of the output. The SO mode is preferably selected to be the output that can least afford to suffer the negative effects of cell chrominance. The ultimate decision regarding the SO and SA modes is preferably based on a global view of overall component performance, which may include multiple color filter/switch stages and multiple polarizers. The priorities are derived from the specifications for a particular application, these include, but are not limited to, the number of outputs, the location of center wavelengths, the bandpass profile, and the throughput requirement for each band. For example, a color sequencer for a digital camera may have optimum spectra that are quite poor for display applications. Other practical issues can also come into play, including the number of allowed polarizers, limitations in drive voltage, characteristics of lamp spectra, and field-of-view requirements. There is clearly no "best-design" that will cover all applications. However, a few examples will be described to illustrate how the present invention can be adapted for different applications.

Most applications will utilize multi-stage color filters, with each color filter stage preferably comprising a pair of retarder stacks with a central LC cell as the modulator. In a multi-stage design, it is preferable for the color filter stages to function independent of one another, so that they can be independently designed and be completely modular. This simplifies the design process, particularly in multi-stage configurations. For example, the retardance of one retarder stack in a multi-stage color filter may be shifted to accommodate the needs of one application, with no impact on the outputs of the remaining color filter stages.

In the interest of maintaining the independence of color filter stages, and obtaining a high density black state or an extremely neutral white state, the SO mode preferably corresponds to the neutral output of each color filter stage. In some instances, however, the designer of the color filter stages does not have this option. For example, in order to have independent color filter stages, each color filter stage must generate an acceptable filtered state, i.e., color coordinate, with no assistance from other color filter stages. Even when an additive primary color is obtained subtractively from two color filter stages, a lack of redundancy in color blocking remains. In other words, an acceptable additive primary color coordinate cannot be achieved unless each color filter stage can generate a high quality subtractive primary color. As a result, priority is frequently given to obtaining acceptable filtered states over ideal neutral states.

There are design schemes that provide a high quality SA filtered state, using chromatic switches, thereby preserving the SO mode for the neutral state. In these design schemes, the LC cell need only switch one additive primary color. Examples of this include R/K (red/black), G/K and B/K, as well as the complements C/W, M/W and Y/W. Assuming that the LC cell is more chromatic in the SA mode than in the SO mode, the density of the black state (or flatness of the white state) is better using SO black (white). Typically, the primary color quality is indistinguishable for SO or SA filtered modes. Stacks of these types of color filter stages are desirable for multi-stage color filters.

When the LC cell must switch between two or more additive primary colors, the situation changes. SA additive

primary with SO white suffers significant degradation in the filtered color coordinate. This is particularly so for SA green, because the active element must rotate the polarization of both blue and red in order to effectively block them. This requires an LC cell that is achromatic throughout the visible spectrum. Accordingly, the SO mode is devoted to the filtered state in order to preserve the color coordinate. Consequently, the white state can have significant short-wavelength blue and long-wavelength red loss. The white state actually appears as if the retarder stacks were removed, leaving only the LC cell oriented at 45-degrees. The retarder stacks, in many cases, improve white transmission, but never appear to degrade transmission when compared to the LC cell alone.

#### Requirements of CSLM Structures

It is assumed that at least partially polarized light is input to the CSLM. While unpolarized light can be introduced, it should be understood that randomly polarized light is not manipulated by the CSLM, and is passed through the CSLM unmodulated. Therefore, we consider the action of the CSLM on the polarized component of the input light. Furthermore, it is assumed that the polarized component of the input light is neutrally polarized over a particular operating band. A "white" state is thus defined as an output transmission that is substantially neutral throughout this particular operating band.

An optimum white state is defined as a transmission function with unity transmission throughout the operating spectral band. For visible operation, the operating spectral band is 400–700 nm. Conversely, a filtered state is one in which the transmission function contains one or more maximum transmission points (ideally zero loss), and one or more minimum transmission points (ideally zero transmission) within the operating band.

#### (A) Neutral Output Requirements

The requirements placed on a single color filter stage for achieving a neutral state will now be discussed. The discussions will focus, in particular, on a maximum throughput white state, with the understanding that such a design can also represent a black state by a suitable rotation of the analyzing polarizer.

Polarized input light can be generated directly, e.g., from a laser, or can be generated by placing a passive polarizer between the light source and the CSLM. While many types of passive polarizers exist, the most common passive polarizers generate linear polarization states. Therefore, the discussion and examples presented concentrate on the special case of linearly polarized input light. However, it should be understood that other neutral light inputs can be generated directly or indirectly using an elliptical polarizer, or an achromatic retarder structure in combination with a neutral linear polarizer.

The color filter stage comprises a retarder structure that contains first and second retarder stacks on either side of an active polarization modulator and an analyzing neutral polarizer (analyzer). The term "neutral" signifies that the polarizer provides substantially constant transmission and polarizing efficiency throughout the operating band. The operating band contains at least one spectral portion that is substantially modulated by the modulator and at least one spectral portion that is substantially unmodulated by the modulator.

If the input light polarization differs from the polarization that is transmitted by the analyzer, an efficient white state requires that the retarder structure perform a neutral polarization transformation. This transformation can be accom-

plished in either the SO or SA modes. For the SO mode, the retarder stacks cooperate to produce a neutral transformation that matches the input light polarization to the exit polarization. The modulator, e.g., the LC cell, thus switches the CSLM structure to one that is substantially more chromatic, thereby accomplishing the desired filtering operation.

For the SA mode, a neutral transformation is accomplished via the action of the retarder stacks with the modulator, or in some cases by the modulator alone. An example of this is the specific case of a linear input polarization state and a linear analyzing polarizer. In the neutral state, using either SO or SA modes, the modulator must rotate the polarization by 0 for a highly efficient white state, or by  $0+\pi/2$  for a black state, where 0 is the orientation of the analyzing (exit) polarizer. Because the modulator performs a relatively neutral operation, it is attractive to consider an arrangement in which the modulator is largely responsible for the characteristics of the neutral state. While the modulator may not be particularly achromatic, an analog modulator may be tuned to position the peak transmission of the neutral spectrum to maximize performance. For instance, a multi-stage color filter may maximize throughput by tuning the peak transmission of the color filter stages in the neutral state to coincide with the peak transmission of a color filter stage in the filtered state.

In the specific case where the analyzing polarizer analyzes the input state of polarization, e.g., x-oriented input polarization and x-oriented linear analyzing polarizer an optimum white state is obtained when the retarder stack structure provides a zero net polarization transformation. This is equivalent to requiring that the input/output polarization be an eigenpolarization of the retarder stack. In this case, a preferred subset of retarder stack designs is one in which the input/output polarization coincides with an eigenpolarization of the retarder structure for one particular state of the LC device. This includes cases where additional retarder stacks are used to produce a neutral polarization state before the chromatic retarder stack, and analyze the neutral polarization state after the chromatic retarder stack, i.e., a Pancharatnam achromatic retarder preceding and following a linear polarizer. However, such solutions are more complex because they require additional retarders.

In the case in which matched input/output polarizations produce a white state in the SO mode, the first retarder stack performs a chromatic polarization transformation that must be fully compensated by the second retarder stack within the operating band. This simply requires that the input polarization correspond to an eigenpolarization of the combined retarder stack. For example, a zero-oriented linear polarization state with an input retarder stack having individual retarder orientations of  $-7.5^\circ$ ,  $52.5^\circ$  and  $67.5^\circ$  can be followed by the second retarder having individual retarder oriented at stack  $67.5^\circ$ ,  $52.5^\circ$  and  $-7.5^\circ$ , yielding a neutral white state. Note that this particular structure is symmetric in both retardation and orientation, thus enabling true reflection mode color filters/switches. It should be further noted that this retarder stack structure requires a specific input State of Polarization, and does not perform identically for other input polarization orientations, e.g.,  $45^\circ$  linear or circular input polarizations.

A "crossed-stack" arrangement provides a family of solutions for SO white that does not depend upon a specific input/output polarization. When two retarders have equal retardation and have crossed orientations, the resulting Jones matrix is the identity matrix. This concept can be extended by adding additional retarders on either side, with each additional pair having the same retardation and crossed

orientations. For any number of retarders conforming to this scheme, there is zero net polarization transformation because the Jones matrices representing each retarder stack are inverses of one another. Because the retarder structure appears isotropic, an optimum white state is obtained for any 5 matched input/output polarization. Optimum stack designs for filtered outputs in the SA mode depend on behavior of the modulator and the chromatic polarization states that are optimally presented by the input retarder stack.

Another case is that in which matched input/output polarizations produce a white state in the SA mode. In this case, the input polarization corresponds to an eigenpolarization of a CSLM structure that now includes both the retarder stacks and the modulator. For example, a zero-oriented linear polarization state with an input retarder stack having individual retarders oriented at  $-7.5^\circ$ ,  $52.5^\circ$  and  $67.5^\circ$ , can be followed by a second retarder stack having individual retarders oriented at  $-67.5^\circ$ ,  $-52.5^\circ$  and  $7.5^\circ$ . This yields a white state with a ZTN half-wave plate (modulator) oriented parallel to the input. The structure thus appears to have the eigenpolarization of the symmetric structure described above. 15

In a second example, the modulator can be used to create the appearance of crossed retarder stacks. Using the above-described input polarization, input retarder stack, and ZTN half-wave plate orientation, the second retarder stack has individual retarders oriented at  $22.5^\circ$ ,  $37.5^\circ$  and  $-82.5^\circ$ . 20

#### (B) Filtered Output Requirements

The demands placed on the color filter structure from a transmission spectrum perspective will now be discussed. As discussed previously, the operating band is defined as having at least one spectral portion in which the polarization is substantially unmodulated by the modulator, e.g., LC device, and at least one spectral portion in which the polarization is substantially modulated by the modulator. In a preferred embodiment, the polarization modulation corresponds to a transmission modulation by a suitable selection of an analyzing polarizer. Furthermore, the modulated spectral portion is preferably modulated between substantially full transmission and substantially zero transmission. This requires that the modulator be capable of modulating between orthogonal polarization states within the modulated portion of the spectrum. The unmodulated portion of the spectrum must retain its polarization state independent of the voltage applied to the modulator. Thus, the transmission must remain substantially fixed (typically full transmission or zero transmission) for any voltage state. 30

The above design considerations are considered with respect to the following filter structure: a modulator positioned between two retarder stacks. The filtered portion of the spectrum is fully modulated between orthogonal states and the unmodulated spectral portion does not "see" the modulator in a way that is significant to its transmission through the filter structure. The polarization of the filtered portion of the spectrum must be properly configured for modulation as in a conventional neutral shutter. The unmodulated portion corresponds to a zero-modulation state of the modulator, i.e., a modulator eigenpolarization. 45

The modulator, whether si compound (i.e., multi-layers of active and/or passive elements), twisted or zero-twist is preferably a device that is interferometric in behavior. That is, there are two orthogonal eigenpolarizations, each with an optically distinct path length. It is assumed that the path length between these waves can be controlled. It is the path length difference between waves, that project onto each eigenpolarization, that influences the state of polarization of light transmitted through the modulator. Preferred modula- 50

tors for the CSLM structures of the present invention are those that have voltage and wavelength stable eigenpolarizations, such as zero-twist nematics (ZTN). Conversely, twisted devices have eigenpolarizations that are relatively sensitive to wavelength and voltage. While many of the structures of the present invention are based on a wavelength effect that is stable over the modulated band, the chrominance of the modulator can, in some instances, be used to enhance the color selection technique. For example, the retarder stacks can open multiple spectral "windows" over which a modulator can modulate. A chromatic modulator can then be used to select which of the spectral bands is transmitted and which is blocked. Accordingly, the performance of most of the structures of the present invention is enhanced by suppressing modulator chrominance. 5

In view of the above discussion, there are exemplary input polarizations for achieving minimum modulation and for maximum modulation potential. Minimum modulation polarizations have projections only along a single eigenpolarization. For a ZTN device, for instance, the minimum modulation polarizations are the ordinary and extraordinary waves. Maximum modulation polarizations correspond to polarization states with substantially equal projections along the eigenpolarizations. For a ZTN device, this is the family of polarizations with arbitrary ellipticity, but with an ellipse axis oriented at  $\pm\pi/4$  to the rub direction. Thus, a retarder stack can generate, for example, linear  $\pm\pi/4$  polarizations or circular polarizations in a particular band, and the modulator can provide full modulation capability for each polarization state. 15

Evaluating the quality of the filtered state is somewhat complex because since no single design is "best" for all applications and output colors. Design considerations such as the width of the passband relative to the stop-band, and the transition slope, all depend upon the specific color being filtered and the application requirements. 20

Preferred spectra for display applications have a frequency domain duty ratio appropriate to the desired spectrum, and have a spectral profile that is rectangular, rather than sinusoidal or some other spectral profile. There may be additional physiological or other reasons why other spectral profiles are preferred. In general, however, the filter should probably have a steep transition slope, with a relatively flat transmission band and a relatively flat blocking band. Relatively flat bands can be achieved by having a series of distributed high-contrast nulls and peaks in the spectrum. Near-ideal transmission spectra can be produced by increasing the number of retarders in the retarder stacks. In practice, acceptable transition slopes and side-lobe amplitudes/locations must be carefully chosen to optimize saturation with a limited number of components. 30

The criteria for evaluating filter designs is based on considerations of saturation, hue, and throughput. The saturation and hue can be evaluated using the CIE chromaticity diagram. The quality of color generated by a particular filter output can be characterized by calculating a series of overlap integrals including the transmission function for a specific filter state the power spectrum of the source, and the CIE color matching functions. 45

Saturated primary colors are generated by maximizing the ratio between the light source power transmitted in the desired primary band to the light source power transmitted outside of the primary band. The filter design can be matched to the light source characteristics to make the optimization very specific. For example, true white sources, such as a 6000 K black body, place greater demand on filter performance than distributed light sources, such as a CRT 50

phosphor or a fluorescent backlight. The spectral positions of nulls in the blocking band depend upon the retardance of the optical components. It is advantageous to strategically place nulls at out-of-band power spectral maxima of the light source. Similarly, it is advantageous to place side-lobe maxima away from out-of-band power spectral maxima. Passive filters can be inserted to reject bands that lie outside of the primary color bands to increase saturation.

#### (C) Retarder Stack Design

The polarization transformation accomplished by each retarder stack is arbitrary, being determined by the retardation and orientation of each retarder film. However, constraints can be placed on retarder stack designs in order to obtain particular results. For instance, when a zero-twist nematic LCD is used as the modulator, the polarization of the center wavelength can be constrained to be a  $\pm\pi/4$ -oriented linear polarization exiting the retarder stack. Consider a retarder stack that is comprised of equal retardation elements, each with a retardation element providing a half-wave retardance, of arbitrary order, at the center wavelength. The following equation must be satisfied:

$$\alpha_N - \alpha_{N-1} + \alpha_{N-2} - \dots \pm \alpha_1 = \pi/8 + m\pi/4, \quad (1)$$

where  $m$  is an integer,  $N$  is the number of retarder elements, and the final sign is determined by whether  $N$  is odd or even.

There are also designs in which the peak modulated wavelength is not a  $\pm\pi/4$ -oriented linear state after the first retarder stack. Consider a red color filter that conforms to a quasi folded Solc design. The retarder stack is made up of polycarbonate retarders which are full-wave at 450 nm. In this case, with  $N=3$ , the rocking angle should be  $7.5^\circ$  for a  $\pi/4$  rotation angle. However, the red color filter design uses a significantly larger  $12^\circ$  rocking angle, giving a  $72^\circ$  rotation angle. This rotation angle corresponds to an 807 nm half-wave wavelength. Not surprisingly, the efficiency is poor for this wavelength, though it lies well beyond the visible. Nevertheless, the efficiency is high at the much shorter 668 nm wavelength, where the retardance is significantly larger than half-wave. In this particular case, the larger rocking angle compensates for the loss in rotation efficiency at the shorter wavelength, yielding the desired intermediate polarization at 668 nm. Full red transmission is possible because the retarder stack generates a  $\pm\pi/4$ -oriented elliptical state.

#### (D) Stack Relationships

In U.S. patent application Ser. No. 08/645,580, which is herein incorporated by reference in its entirety, structures were disclosed that generate an achromatic white state or black state by producing an identity Jones matrix between parallel polarizers for the white state, or crossed polarizers for the black state. For an arbitrary input retarder stack, the inverse retarder stack is produced by reversing the order of the individual retarders, and rotating each individual retarder  $\pi/2$  from the corresponding individual retarder in the input retarder stack. The transmission is unity for all wavelengths, assuming lossless components and assuming that the modulator between the crossed retarder stacks is made to vanish. In the crossed retarder stack arrangement, the white state quality is insured regardless of the modulator orientation or the electrooptic effect, provided the modulator can be made to effectively vanish. Thus, the filtered state can be designed without having to consider the impact on the white state quality. One result of such independent design characteristics is that SO neutral configurations can be readily adapted into multiple stage filter designs.

Part of the present invention is the discovery that, by orienting a zero-twist nematic (ZTN) LC modulator at 0 or  $\pi/2$  between crossed retarder stacks, many useful filtering

operations can be obtained. Assuming that the input retarder stack has individual retarders oriented at  $\alpha_1, \alpha_2, \dots, \alpha_N$ , the second retarder stack has individual retarders oriented at  $\pi/2 + \alpha_N, \dots, \pi/2 + \alpha_2, \pi/2 + \alpha_1$ . Assuming that the ZTN LC modulator is a half-wave retarder over the modulated bandwidth, the ZTN LC modulator, in the SA mode, effectively switches the angle of each individual retarder in the second retarder stack to  $\pi/2 - \alpha_N, \dots, \pi/2 - \alpha_2, \pi/2 - \alpha_1$ .

Accordingly, the states are inverted by simply giving the individual retarders in the second retarder stack the effective orientation produced in the SA mode with crossed retarder stacks. This produces a SA white state, subject to the effects of the LC modulator chrominance on white-state transmission. Such SO filtered configurations are valuable when the effects of LC modulator chrominance on the quality of a filtered state are intolerable.

In addition, the SA white state quality is substantially determined by the LC modulator chrominance alone and, as such, can be tuned to provide maximum transmission at an arbitrary wavelength. This is important for providing high throughput in multi-stage SA white filters. The effect of the retarder stack on the white state, if any effects are observed at all, is to increase the transmission. The retarder stack has never been found to degrade the transmission of the white state.

Designs in which the SA white states are compromised by the LC modulator chrominance alone are generally preferred over designs with SO white outputs with similar chrominance. SO white output designs refer to designs that use the retarder stacks to produce a quasi-neutral transformation to yield a white state. The SA white designs are preferred in multi-stage filters because the white state can be tuned to maximize throughput. In contrast, the SO white state has a fixed chrominance that represents a loss of throughput.

Examples of CSLM devices that represent a range of design options for modulating between neutral and filtered transmission spectra will now be discussed. All of the CSLM devices discussed use ZTN LC devices for the modulator. However, different options for the modulator orientation, retarder stack interactions, and polarizer orientations will be discussed.

#### SO White, 0°-Oriented ZTN LC Modulator, Parallel Polarizer

One embodiment of the CSLMs of the present invention comprises crossed retarder stacks and parallel polarizers, and: gives a substantially ideal SO white output. The CSLM structure is shown in FIG. 2. The CSLM structure comprises a ZTN LC modulator **100**, a first retarder stack **110** and a second retarder stack **120**. The ZTN LC modulator **100** and the retarder stacks **110** and **120** are positioned between input polarizer **130** and output polarizer **140**. The orientation of the input polarizer **130** is parallel to the orientation of the output polarizer **140**. The ZTN LC modulator **100** is oriented parallel or perpendicular to the input polarizer **130**, and provides a half-wave of retardance at the center wavelength of the modulated band. In the SA mode, the half-wave ZTN LC modulator **100** reflects the input polarization about the input polarization axis, thereby changing the apparent orientation of one retarder stack **110** relative to the other retarder stack **120**. The crossed-stack CSLM shown in FIG. 2 is a magenta/white color filter that uses three individual retarders, preferably retarder films, in each retarder stack and a rocking angle of  $7.5^\circ$ . Specifically, the first retarder stack **110** comprises a first retarder film **110A** oriented at  $7.5^\circ$  with respect to the input polarizer **130**, second retarder film **110B** oriented at an angle of  $-7.5^\circ$  with respect to the

input polarizer **130** and the retarder film **110C** oriented at an angle of  $7.5^\circ$  with respect to the input polarizer **130**. Retarder stack **120** comprises first, second and third retarder films **120a**, **120b** and **120c** oriented at angles of negative  $82.5^\circ$ ,  $82.5^\circ$  and  $-82.5^\circ$ , respectively, with respect to the input polarizer **130**. All of the individual retarders in the first and second retarder stacks **110** and **120** are 1.5-wave retarders in the green (540 nm), giving a  $\pi/4$  polarization rotation (half-wave retardance) for green light. Note that this color filter design satisfies the generating function discussed above, so that 540 nm light is linear  $\pi/4$  oriented after the first retarder stack **110**. This makes green light fully available for modulation by the 0-oriented ZTN LC modulator. Both blue and red light remain oriented along the polarization axis of the input polarizer **130**, which coincides with an eigenpolarization of the ZTN LC modulator **100**. Therefore, there is no mechanism for the ZTN LC modulator **100** to modulate blue/red polarization, independent of any LC retardation. The transition bands between blue/green and green/red are steep, resulting in a square notch in the filtered state. The spectrum is characterized by three maxima in each pass-band (blue/red), and two nulls in the stop band (green). The amplitude of the side lobes between the peaks/nulls is approximately 1%.

Because only one additive primary band is switched by the ZTN LC modulator, the effects of modulator chrominance on the SA spectrum are almost undetectable. The white spectrum is substantially ideal because the first and second retarder stacks **110** and **120** are crossed.

#### Embodiment 2: SA Crossed Stack, $0^\circ$ -Oriented ZTN LC Modulator, Parallel Polarizer

FIG. 3 magenta/white M/W color filter similar to the color filter shown in FIG. 2, except that the color filter of FIG. 3 transmits a white output in the SA mode. Like the color filter shown in FIG. 2, the ZTN LC modulator **100** is oriented parallel or perpendicular ( $\pi/2$ ) to the input polarizer **130**, so that the modulator **100** will modulate  $45^\circ$  polarized light and pass light that is oriented along the polarization axis of the input, polarizer **130** unchanged.

The first retarder stack **110** comprises individual retarder films **210a**, **210b** and **210c** oriented at  $7.5^\circ$ ,  $-7.5^\circ$ , and  $7.5^\circ$ , respectively, with respect to the input polarizer **130**. The second retarder stack **120** comprises individual retarder films **220a**, **220b** and **220c** oriented at  $82.5^\circ$ ,  $-82.5^\circ$  and  $82.5^\circ$ , respectively, with respect to the input polarizer **130**. The individual retarder films in the first and second retarder stacks **110** and **120** are 1.5-wave retarders in the grain (140 nanometers). Accordingly, the first and second retarder stacks each give a  $\pi/4$  polarization rotation (half-wave retardance) for green light. The exit polarizer **140** is oriented with its polarization axis parallel to the polarization axis of the input polarizer **130**. Accordingly, the light output is modulated between a magenta state and a white state.

For orientations of the ZTN LC modulator **100** other than 0 or  $\pi/2$ , designs can be generated for SA white states by considering the effective input to the second retarder stack **120**. For example, the orientation of the second retarder stack **120** and the exit polarizer **140** can be selected to provide effectively crossed retarder stacks and parallel polarizers. This white state is substantially ideal insofar as the modulator **100** is achromatic over the entire modulated band.

A modulator with orientation  $\alpha_{LC}$  produces an effective input polarization of  $2\alpha_{LC}$ , with an effective input stack with orientations  $2\alpha_{LC}-\alpha_1$ ,  $2\alpha_{LC}-\alpha_2$ ,  $2\alpha_{LC}-\alpha_N$ . Thus, an effective

crossed stack white output can be generated by orienting the exit polarizer **140** at  $2\alpha_{LC}$  and the second retarder stack at  $\pi/2+2\alpha_{LC}-\alpha_N, \dots, \pi/2+2\alpha_{LC}-\alpha_2, \pi/2+2\alpha_{LC}-\alpha_1$ .

#### Embodiment 3: SO Crossed-Stack, $\pi/4$ -Oriented ZTN LC Modulator, Crossed Polarizer

FIG. 4 shows another embodiment of a color filter with a magenta/white output. Like the embodiments shown in FIGS. 2 and 3, the input and exit polarizers **130** and **140** are oriented parallel with respect to each other. However, the ZTN LC half-wave modulator **100** is oriented at the  $\pm\pi/4$  with respect to the input polarizer **130**. Thus, the modulator **100** modulates the polarization of light that is oriented parallel to the polarization axis of the input polarizer **130**, and leaves the polarization of light that is oriented at  $\pm\pi/4$  with respect to the input polarizer **130** unchanged.

In order to obtain a M/W output like the color filter shown in FIGS. 2 and 3, the first and second retarder stacks **110** and **120** are modified so that they each provide full-wave retardance in the green (140 nanometers). As in the color filter shown in FIG. 2, the first and second retarder stacks **110** and **120** are crossed with respect to each other, thus providing a substantial ideal so white output.

The first retarder stack **110** comprises individual retarders **310a**, **310b** and **310c**, oriented at  $22.5^\circ$ ,  $75^\circ$  and  $-60^\circ$ , with respect to the input polarizer **130**. The second retarder stack **120** comprises individual retarders **320a**, **320b** and **320c**, oriented at  $30^\circ$ ,  $-15^\circ$  and  $-67.5^\circ$ , respectively, with respect to input polarizer **130**.

#### Embodiment 4: SA Crossed-Stack, $\pi/4$ -Oriented ZTN LC Modulator, Crossed Polarizer

FIG. 5 shows another embodiment of a CSLM **10** similar to the CSLM shown in FIG. 4, except that a white output is achieved in the SA mode. The ZTN LC half-wave modulator **100** reflects the state of polarization, such that the input polarization appears to be oriented at  $\pi/2$ , and the first retarder stack **110** "appears" to have orientations  $\pi/2-\alpha_1$ ,  $\pi/2-\alpha_2, \dots, \pi/2-\alpha_N$ . A SA white state is generated by creating the "appearance" of crossed retarder stacks and parallel polarizers. This is done by orienting the exit polarizer **140** at  $\pi/2$ , and orienting the individual retarders second retarder stack **120** at  $-\alpha_N, \dots, -\alpha_1$ . The resulting structure has first and second retarder stacks **110** and **120** of opposite sign.

The embodiment shown in FIG. 5, the first retarder stack **110** comprises individual retarders **410a**, **410b** and **410c**, oriented at  $22.5^\circ$ ,  $75^\circ$  and  $-60^\circ$ , respectively, with respect to the input polarizer **130**. The second retarder stack **120** comprises individual retarders **420a**, **420b** and **420c**, oriented at  $60^\circ$ ,  $-75^\circ$  and  $-22.5^\circ$ , respectively, with respect to the input polarizer **130**. The individual retarders in the first and second retarder stacks **110** and **120** provide full-wave retardance at 540 nanometers.

#### Embodiment 5: SO White (Eigenpolarization), $\pi/4$ -Oriented ZTN LC Modulator, Parallel Polarizer

An alternative to crossed retarder stacks is to achieve a neutral output using an eigenpolarization of the CSLM structure. FIG. 6 shows another embodiment of the CSLM **10** that is a modification of the CSLM embodiment of FIG. 5. In the CSLM **10** of FIG. 6, a white output is obtained in the SO mode using an eigenpolarization. A  $\pm\pi/4$  oriented ZTN LC modulator **100** is used in this embodiment to modulate spectrums with 0 and/or  $\pi/2$  oriented polarizations.

## 21

The CSLM **10** of FIG. **6** is a M/W CSLM, with the individual retarders in the first and second retarder stacks **110** and **120** providing two full-waves of retardance at 540 nm (green). The first and second retarder stacks **110** and **120** are each half-wave retarders in the blue and red bands, with the first retarder stack **110** generating  $\pm\pi/4$  oriented polarizations in the blue and red bands. As such, the ZTN LC modulator **100** does not modulate the state of polarization of the blue and red bands.

In the specific embodiment of FIG. **6**, the first retarder stack comprises individual retarders **510a**, **510b** and **510c**, oriented at  $22.5^\circ$ ,  $75^\circ$  and  $60^\circ$ , respectively, with respect to input polarizer **130**. The second retarder stack **120** comprises individual retarders **520a**, **520b** and **520c**, oriented at  $-60^\circ$ ,  $75^\circ$  and  $22.5^\circ$ , respectively, with respect to input polarizer **130**.

Embodiment 6: SA White (Eigenpolarization),  $\pi/4$ -Oriented ZTN LC Modulator, Crossed Polarizer

In the CSLM of FIG. **7**, the ZTN LC modulator modifies the appearance of the first retarder stack, thus generating a filtered output. In the half-wave retardance state, the input and exit polarizers **130** and **140** appear crossed, and the first retarder stack “appears” to have orientations  $67.5^\circ$ ,  $15^\circ$  and  $-30^\circ$ .

In CSLM **10** shown in FIG. **7**, the input and exit polarizers **130** and **140** are crossed, and the individual retarders **610a**, **610b** and **610c** in the first retarder stack **110** are oriented at  $67.5^\circ$ ,  $15^\circ$  and  $-30^\circ$ , respectively, with respect to the input polarizer **130**. The individual retarder **620a**, **620b** and **620c** in the second retarder stack **120** have the same orientations as the corresponding individual retarders shown in FIG. **6**.

The configuration shown in FIG. **7** generates a white state in the SA mode as an eigenpolarization.

Embodiment 7: SO White (Eigenpolarization),  $0^\circ$ -Oriented ZTN LC Modulator, Parallel Polarizer

The CSLM embodiment shown in FIG. **8** uses the same retarder stack configuration used in the CSLM of FIG. **6**. However, a different filtered state is generated by orienting the ZTN LC modulator **100** at  $0^\circ$ . Since the neutral output is obtained in the SO mode, it’s spectrum is unchanged at normal incidence. The  $0^\circ$ -oriented ZTN LC modulator **100** modulates  $\pm\pi/4$  oriented polarizations. Therefore, a green modulator (M/W design) uses retarder stacks **110** and **120** comprised of green (540 nm) half-wave individual retarders **710a**, **710b**, **710c**, **720a**, **720b**, and **720c**. In the SA mode, the ZTN LC modulator **100** creates the “appearance” of switching the signs of the angles in one of the retarder stacks.

Embodiment 8: SA White (Eigenpolarization),  $0^\circ$ -Oriented ZTN LC Modulator, Parallel Polarizer

A SA white state can be obtained as an eigenpolarization by reversing the signs of the angles of the individual retarders in one of the retarder stacks (**110** or **120**) of the CSLM **10** shown in FIG. **8**. As such, the filtered output is obtained in the SO mode.

A CSLM embodiment that incorporates disconfiguration is shown in FIG. **9**. In this embodiment, the first retarder stack **110** comprises individual retarders **810a**, **810b** and **810c** that have the same orientation as the individual retarder **710a**, **710b** and **710c** shown in FIG. **8**. The second retarder stack **120** comprises individual retarders **820a**, **820b** and **820c**, oriented at  $60^\circ$ ,  $-75^\circ$  and  $-22.5^\circ$ , respectively. Like in the CSLM shown in FIG. **8**, the ZTN LC modulator **100** in the embodiment shown in FIG. **9** is orientated at  $0^\circ$ .

## 22

Embodiment 9: SA White with Tunable Peak Transmission

When the chrominance of the modulator is too large for generating spectra with adequate saturation in the SA mode, such spectra are best generated in the SO mode. Consequently, the white state reflects the loss in transmission characteristic of most LC shutter devices in the open state. However, like ZTN neutral shutters, the peak transmission of the white state of the CSLM can be tuned to maximize throughput. FIG. **10** shows a SO green CSLM **10** with a tunable white state.

The ZTN LC modulator **100** is tunable so that the peak transmission of the white state of the CSLM **10** can be tuned to maximize throughput. The input and output polarizers **130** and **140** have crossed orientations. The first retarder stack **110** comprises individual retarders **910a**, **910b** and **910c** oriented at  $7.5^\circ$ ,  $-7.5^\circ$  and  $52.5^\circ$ , respectively. The second retarder stack **120** comprises individual retarders **920a**, **920b** and **920c** oriented at  $-52.5^\circ$ ,  $7.5^\circ$  and  $-7.5^\circ$ . The ZTN LC modulator **100** is oriented at  $45^\circ$ .

Reflection Mode CSLM

The first retarder stack **110** comprises a plurality of individual retarders **1010a**, **1010b**, . . . **1010c** having retardances  $\Gamma_1$ ,  $\Gamma_2$ , . . .  $\Gamma_N$ , respectively, and orientations  $\alpha_1$ ,  $\alpha_2$ , . . .  $\alpha_N$ , respectively. The second retarder stack **120** comprises a plurality of individual retarders **1020a**, . . . **1020b** and **1020c** having orientations  $\alpha'_1$ , . . .  $\alpha'_2$ ,  $\alpha'_1$ . The individual retarders and the second retarder stack **120** have the same retardances as the individual retarders in the first retarder stack **110**, but with the order reversed. It should be appreciated that, for illustrative purposes, each of the first and second retarder stacks **110** and **120** are shown with three individual retarders. It should be understood that the number of individual retarders included in each of the retarder stacks **110** and **120** can be less than or greater than three.

A reflection mode CSLM **20** is shown in FIG. **12**. The reflection mode CSLM **20** comprises an input polarizer **130**, a reflector **1100** and a retarder stack **1200** positioned between the input polarizer **130** and the reflection **1100**. The retarder stack **1200** comprises a plurality of individual retarders **1210a**, **1210b** . . . **1210c** having retardances  $\Gamma_1$ ,  $\Gamma_2$ , . . .  $\Gamma_N$  and orientations  $\alpha_1$ ,  $\alpha_2$ , . . .  $\alpha_N$ , respectively. In operation, light passes through the input polarizer **130**, through the individual retarders **1210a**, **1210b** . . . **1210c**, reflects from the reflector **1100**, passes back through individual retarders **1110c** . . . **1210b**, and **1210a** and passes back through input polarizer **130**. Accordingly, the input polarizer **130** also functions as an exit polarizer, and the retarder stack **1200** functions as both the first and second retarder stacks.

To more clearly illustrate the path light takes through the reflection mode CSLM **20**, an “unfolded” version of the reflection mode CSLM is shown in FIG. **13**.

The reflection mode CSLM **20** has the constraint that  $\alpha'_i = \alpha_j$ . While achromatic transformations can be inserted to broaden the range of design choices (Ammann and Yarborough), it is most desirable to avoid such transformations, thereby simplifying the stack design. In a retroreflecting arrangement, the unfolded version shows that the polarizers are parallel and the layers in corresponding retarder stacks have identical orientations. If a polarization splitter is used, there is an option between a parallel polarizer output or a crossed polarizer output.

FIG. **14** is a table that lists designs with  $N=3$  that have the required symmetry for implementing a reflection mode

device. FIGS. 15a, and 15b are plots of the measured output of reflection mode magenta and yellow CSLMs, respectively. A cyan CSLM uses design #8 listed in FIG. 14, with full-wave polycarbonate retarders at 430 nm. The magenta and yellow CSLMs use design #5 listed in FIG. 14. The magenta CSLM uses 1.5-wave polycarbonate retarders at 540 nm, and the yellow CSLM uses 1.5-wave polycarbonate retarders at 460 nm. All CSLMs were constructed with two sheets of Nitto-Denko EG 1425 DU iodine polarizers, which forms the envelope of the white outputs. The transparent electrode losses also contribute to the shape the output profile.

#### Other Embodiments

The CSLM embodiments discussed above primarily utilize an LC modulator to control the transmission of one portion (spectrum) of the operating band, while maintaining fixed transmission of the complementary spectrum. Preferred embodiments are those in which the unmodulated spectrum is either fully transmitted or fully extinguished. The embodiments in which the unmodulated spectrum is fully transmitted represent variable saturation CSLMs, because the LC modulator modulates between a white state and a filtered state that is substantially more saturated. The embodiments in which the unmodulated spectrum is fully extinguished are variable luminance CSLMs, because the LC modulator modulates between a filtered state and a black state. In many instances, a variable luminance CSLM permits full modulation from a filtered state to a black state with fixed color coordinates.

Another type of filter is a variable hue filter. A variable hue filter is one with both end points on the CIE diagram corresponding to filtered states. The action of the LC modulator(s) is thus to modulate between two filtering operations, rather than a filtered state and a neutral state. Examples of some variable hue filters are provided in U.S. Pat. No. 5,751,384, the embodiments of which are incorporated herein by reference. CSLM structures also permit such operations.

FIG. 16 shows a variable hue filter (CSLM) 10 that switches between a green output and a magenta output. This can be compared to the G/M output of a stage utilizing an LC switch external to a retarder stack color polarizer (SPF). In such an arrangement, the green and magenta spectra are exact inverses, intersecting at the 50% transmission points. However, the G/M spectra of the CSLM 10 may not be exactly complementary. The sum of the two spectra actually has notches in the true cyan and true yellow bands, which is desirable for display applications. Like the standard SPF, the two spectra can be generated by rotating a half-wave retarder by  $\pi/4$ .

In the CSLM embodiment of FIG. 16, a compound half-wave modulator 1300 is used as the modulator and achromatizes the  $\pi/4$  orientation. The compound half-wave modulator 1300 comprises an in-plane switching (IPS) modulator 1310, and half-wave retarders 1320 and 1330 positioned on each side of the IPS modulator 1310 and orientated at  $15^\circ$ . A first retarder stack 110 comprise s individual retarders 1400a, 1400b and 1400c oriented at  $7.5^\circ$ ,  $-7.5^\circ$  and  $7.5^\circ$ , respectively. A second retarder stack 120 comprises individual retarders 1410a, 1410b and 1410c oriented at  $-82.5^\circ$ ,  $82.5^\circ$  and  $82.5^\circ$ , respectively. The compound half-wave 1300 is positioned between the first retarder stack 110 and the second retarder stack 120, which are all positioned between parallel polarizers 130 and 140.

When the IPS modulator 1310 is oriented at  $5\pi/12$ , a green output with a 40 nm bandpass width is transmitted.

When the IPS modulator 1300 is rotated to  $2\pi/3$ , a magenta with half maximum points at 494 nm and 596 nm is output. The spectra overlap at the 10% transmission points.

#### Multiple Stage Filters

Multiple stage CSLMs comprise two or more retarder stack/modulator stages in series with one or more analyzing polarizers. Each retarder stack/modulator stage comprises a modulator with a retarder stack positioned on each side of the modulator. The polarizers are typically neutral, but polarizers designed to analyze a particular spectral component can separate retarder stack/modulator stages. Examples of two-polarizer and four-polarizer full color multiple stage CSLMs are used by way of illustrating issues that arise when retarder stack/modulator stages are cascaded. Multi-stage CSLMs can be used as color sequencers, as will be explained in more detail below.

FIGS. 17a and 17b are block diagrams of a two-polarizer, three-stage CSLM, and a four-polarizer, three-stage CSLM, respectively. The two-polarizer, three-stage CSLM comprises an input polarizer 1450, a red stage 1420, a green stage 1430, a blue stage 1440 and an output polarizer 1460 that is crossed with respect to the input polarizer 1450. The four-polarizer, three-stage CSLM generally comprises an input polarizer 1450, a red stage 1420, a polarizer 1470 for analysing a spectral component transmitted by the red stage 1420, a green stage 1430, a polarizer 1480 for analysing a spectral component transmitted by the green stage 1430, a blue stage 1440 and a polarizer 1490 for analysing a spectral component transmitted by the blue stage 1440.

Note that the actual number of stages is arbitrary. In addition, although red, green and blue stages are shown for illustrative purposes in the CSLMs of FIGS. 17a and 17b it should be appreciated that stages that modulate other colors maybe used. Most of the CSLM designs discussed above allow the modulators in each of the CSLM stages to be pixellated, in order to permit common-path full color displays using video rate panels. A few of the CSLM designs discussed above are intended specifically for either additive primary or subtractive primary color generation only.

#### Two-Polarizer, Three-Stage CSLM

An important benefit of a two-polarizer multi-stage CSLM, such as the general one shown in FIG. 17a, is high light efficiency, because it only requires a polarized input and a single analyzing polarizer following the last individual retarder stack/modulator stage. The analyzing polarizer can be mounted external to the retarder stacks and modulators to increase power handling and/or to capitalize on polarizers already in the system, as in LCD sequential projectors. Should the input light be unpolarized, a polarizing beam-splitter can be used to form two optical paths. These paths can be processed separately by the retarder stacks and modulators and recombined with a second polarization splitter. This in principle, represents a substantially lossless filtering operation. This is accomplished without increasing the etendue of the system, provided that components subsequent to the multi-stage CSLM are not sensitive to polarization. Such is the case with a digital micromirror device (DMD).

The challenge in designing a full-color multi-stage CSLM with one analyzing polarizer is to minimize the interaction between the retarder stack/modulator stages. Because the state of polarization is not analyzed after each retarder stack/modulator stage, the stages interact on a field basis, rather than on a power transmission basis. The two-polarizer

design thus requires greater independence of stages than the four-polarizer design. Since a polarization analyzer does not isolate the stages, any polarization effects introduced by modulator chrominance (or off-normal input light) in the neutral state represents a degradation in color coordinates for any retarder stack/modulator stage in the filter state. As the quality of the neutral state improves (the density of the black state or the flatness of the white state), the independence of the stages likewise improves, making SO neutral states a desirable design choice.

A significant benefit of the two-polarizer design is the greater number of design options available relative to four-polarizer designs. In particular, the two-polarizer CSLM can be operated in an additive mode. As discussed above, stages behave as variable saturation filters in subtractive mode, and as variable luminance filters in additive mode. When only one polarization analyzer is used, designs that use a black state rather than a white state can be considered. A black state simply means that a particular stage “vanishes” between crossed polarizers, rather than parallel polarizers. The term “vanishes” is used to indicate that the polarization of input passing through the stage is preserved. Thus, it is as though the stage is not present. In the context of a multiple-stage CSLM, a black state does not preclude other output spectra, because other stages remain available to switch to the filter mode. Conversely, a four-polarizer filter, using all neutral polarizers, requires that white be a common output of every retarder stack/modulator stage. Thus, by simply rotating the analyzing polarizer, the CSLM is converted from a subtractive filter to an additive filter, with some important performance implications.

A benefit of the additive mode design is that it gives preference to the quality of the additive primary colors and black, rather than the subtractive primary colors and white, which is important in display applications. When the input and output polarizers are crossed, the quality of the black state is primarily compromised by any inability to make the structure between the polarizers vanish. Conversely, when the input and output polarizers are parallel, a black state relies on the structure between the polarizer to convert the polarization to the orthogonal state. Using a full-color subtractive mode structure, this requires the cooperation of three retarders stack/modulator stages, each responsible for rotating the polarization of one additive primary color to the orthogonal state. This is typically a formidable task.

Other benefits are associated with the generation of color. The additive mode design generates an additive primary directly using a single stage, requiring no cooperation between stages. Each stage can thus be designed independently, without regard for the characteristics of the other stages, provided that the neutral states are of adequate quality. Therefore, with an additive mode CSLM, stages ideally “vanish” in the SO mode and each stage is responsible for independently determining the transmission of one additive primary color.

When generating subtractive primaries additively, losses in performance due to interaction between stages is frequently of lesser consequence than when generating additive primaries subtractively. It should be noted that, by conservation of power, the transmission spectra of additive and subtractive filters are inverses of one another. With this in mind, it is chromatically more tolerable to have a true yellow notch in the yellow spectrum than a yellow side lobe in the blue spectrum. Similarly, it is chromatically more tolerable to have a true cyan notch in the cyan spectrum than a true cyan side lobe in the red spectrum. Most importantly, true cyan and true yellow notches in the white output are less significant than true cyan and true yellow side lobes in the black state.

### A Projection Display KGB Digital Color Sequencer

In a projection display, maintaining high light efficiency is a high priority. In addition, a digital color sequencer (DCS) must handle the high light level of the projector lamp. Accordingly, internal polarizers are preferably eliminated from the DCS design. In order to not decrease throughput, the DCS preferably does not create a bottleneck in view time, or duty ratio. Accordingly, the transient behavior of the CSLM must be considered. Fortunately, the field of view requirement is relaxed for to direct view systems, which is beneficial in two-polarizer designs. Typically, a 10°–15° half-cone angle is acceptable. Given these priorities, a preferred embodiment for a projector DCS will now be described. Note that, while much of the discussion centers around single-pixel color sequencers, this example also applies to stacked three-stage, pixelated color displays.

A preferred CSLM design for the projector DCS is a two-polarizer additive (SO black) design, with a SA red stage **1440**, a SA green stage **1430** and a SA blue stage **1420**, as shown in FIG. **18**.

The blue stage **1420** comprises a first stack **1470**, a 450 nm half-wave LC modulator **1480** and a second retarder stack **1490**. The green stage **1430** comprises a first retarder stack **1500**, a 540 nm half-wave LC modulator **1510** and a second retarder stack **1520**. The red stage **1440** comprises a first retarder stack **1530**, a 650 nm half-wave LC modulator **1540** and a second retarder stack **1550**. The retardances and orientations of the individual retarders that comprise retarder stacks **1470**, **1500**, **1520**, **1530** and **1550** are listed in FIG. **18** and will not be discussed. LC modulators **1480**, **1510** and **1540** are oriented at 90°. The individual retarders that make up retarder stacks **1470**, **1490**, **1500**, **1520**, **1530** and **1550** are preferably Z-stretched polymer films, such as Nitto NRZ™ polymer films.

The design of FIG. **18** has three LC modulators **1480**, **1510** and **1540**, while DCS based on complementary color switching has only two, this design provides important advantages. First, the three-stage design eliminates the internal polarizer required in complementary two-stage designs. With properly selected glass, conductive coatings, and spacer densities, stage losses can be reduced to approximately 1–2% per stage, while each dye-stuff polarizer represents more than 16% loss.

Second, the spectra from each stage of the FIG. **18** design are independent of one another, unlike complementary retarder stack based designs, which overlap at the 50% transmission point.

Third, the LC modulators **1480**, **1510** and **1540** each need only be achromatic over one additive primary color band, while complementary-based designs (assuming redundant blocking) require achromatic behavior over two additive primary color bands.

Fourth, the retardances of the LC modulator **1480**, **1510** and **1540** have no significant influence on the color coordinate of the three-stage DCS, unlike complementary-based filters. This makes the DCS very robust, because the spectra are independent of the detailed characteristics of the LC modulators.

Fifth, the design of FIG. **18** permits nearly 100% viewing due to its desirable transient behavior, as will be discussed in more detail below.

FIG. **19** is a truth table for the DCS of FIG. **18**. With all LC modulators driven high (the “off” state), the black state is obtained. To the extent that the partial stacks are identical in retardation and are accurately crossed, and that the cell

can be made to completely vanish, the contrast ratio is polarizer limited. Given reasonable fabrication tolerances, a 200:1 average contrast can be achieved using properly compensated LC devices.

Independent optimization of each retarder stack allows one to achieve near ideal color coordinates without the loss associated with additional notch filters. Such filters might otherwise be required in complementary-based designs to reject interprimary light. Achieving acceptable color coordinates depends upon the lamp spectrum (and chromatic losses in the system), the number of individual retarder films in the retarder stack, and the specific primary band modulated by the stage. As the center wavelength of the bandpass increases, it becomes necessary to increase the number of retarder films to maintain performance. In the B/K stage **1420** for example, only three of retarder films are used for each of the first and second retarder stacks **1470** and **1490**, because the  $\Delta n(\lambda)/\lambda$  dependence of retardation serves to improve the stop-band width. Generally, a blue stage using retarder stacks with two or three individual retarder films gives acceptable coordinates.

Conversely, the  $\Delta n(\lambda)/\lambda$  dependence of retardation tends to reduce the stop-band width for the R/K stage **1440**. Accordingly, additional retarder films are preferably used in the retarder stacks **1530** and **1550**. For example, a  $1.5\lambda$  red retarder film used in a retarder stack is  $2.5\lambda$  in the blue, resulting in a magenta output. This can be addressed by using the LC modulator chrominance to eliminate the blue order, and by using the blue stage **1420** to further reduce blue transmission. However, this type of design is less robust because it relies on modulator retardance control and cooperation between stages to achieve acceptable spectra. As discussed above, it is preferable for each stage to be independent of the others. When  $0.5\lambda$  red retarders are used, the blue order is safely eliminated, but the transition slope is shallower. While this allows the stages to be independent, the value of  $N$  (the number of individual retarders) must be increased to sharpen the transition slope and give an acceptable color coordinate.

FIGS. **20a**, **20b** and **20c** show the measured red, green and blue transmission spectra, respectively, for the fully assembled RGB DCS of FIG. **18**. The peak transmission for each spectrum shows losses associated only with the packaged RGB DCS. This includes substrates, retarder stacks, adhesives, ITO films, and LC films. AR coatings are provided on external surfaces, but the RGB DCS is packaged without the polarizers.

FIGS. **21a**, **21b** and **21c** show additional measured cyan, magenta and yellow spectra that are also available with the RGB DCS of FIG. **18**. No attempt was made to optimize the CMY spectra. Should more equal weighting be applied to the quality of the subtractive spectra, as opposed to considering the additive primaries only, adjustments be made to improve the interaction between the stages.

While the DCS of FIG. **8** can be operated in a cyclic R, G, B mode, which mimics the function of a rotating color filter wheel, it is capable of much more. For example, by changing the drive scheme, the viewing duration of each primary (and white if appropriate) can be adjusted. More generally, within a single frame period, the number of viewings of each color, their duration, the order in which they are presented, and the transmission level are all arbitrary and electronically selectable. By driving the LC modulators **1480**, **15120** and **1540** in an analog mode, arbitrary admixtures of the primary colors can be generated for color balance in sequential systems, or for color balance of a true

white frame. FIGS. **22a**, **22b** and **22c** show the measured output of the red stage **1440**, green stage **1430** and blue stage **1420**, respectively, before they were assembled into the DCS of FIG. **8**. FIGS. **22a** and **22b** show the measured output of the blue stage **1420** and green stage **1430**, respectively, at different modulator driving levels, i.e., driving their respective modulators **1480** and **1510** in an analog mode. As can be seen in FIGS. **22a** and **22b**, discrete transmission levels can be achieved, thereby allowing full modulation capabilities. Although not shown in FIG. **11c** the red stage **1440** can be driven in a similar manner.

#### Transient Behavior of a Two-Polarizer DCS

Asymmetric rise/fall times characterize the switching of nematic LC devices. A sufficient electric field applied across an LC film, which opposes the elastic forces, reconfigures the molecular director distribution in approximately 50–100 microseconds. When the field is removed, there is a relatively slow (approximately 500 microseconds to more than 1 millisecond) relaxation to the original distribution. Because this restoration is not electric field assisted, improvements in the reset time are accomplished by modifying the cell geometry, the surface treatment and the physical properties of the LC fluid. Surface mode devices are attractive because they provide sub-millisecond relaxation to the half-wave state, where other LC effects are either significantly slower or require very thin cell gaps. Surface mode devices can be driven to zero retardance in roughly 50 microseconds without difficulty.

The transient behavior of the preferred DCS design takes advantage of this difference in switching speed to maintain color coordinates, thereby eliminating the tradeoff between view time and saturation. For most ZTN modulator devices, maximum retardation is provided in the undriven state, with nearly zero in-plane retardation in the driven state. In the context of the preferred DCS design, this allows one to drive from any filtered state to a black state very rapidly.

As the stage corresponding to one primary color, e.g., green, is driven high, the modulator for the subsequent color, e.g., red is turned off. In less than 100 microseconds, the CSLM switches from green to black. Over the course of 1 millisecond, the retardance of the red modulator increases, allowing red transmission to increase to 100%. During this time, only the wavelength band established by the retarder stacks of the red stage is allowed to be transmitted, independent of the modulator retardance. As such, the color coordinate remains substantially constant as the transmission increases. It is only the relatively inconsequential chromatic behavior of the modulator over the additive primary band that can influence the color coordinate (at normal incidence). Using this scheme in a full-color sequential system, the CSLM (sequencers) can be viewed continuously, without blanking the display, with no impact on color quality.

There are also display modes in which the one-millisecond transition to the 100% transmission state can be beneficially used. In pulse width modulated displays, the resolution can be limited by the luminance step of a single frame. This step is determined by the minimum view time of a single frame under full illumination. A method for increasing resolution is to insert one or more frames of imagery with reduced illumination level, thereby increasing the view time to a manageable duration.

If there is a throughput benefit in decreasing the transition time between colors, alternative drive schemes may be considered. In a two-polarizer DCS, the interval between the

driven state (black mode) and the undriven state (filtered mode) can determine throughput if the display is relatively fast. It is important to reach a half-wave retardance in the center of the operating band as quickly as possible, and to maintain that retardance throughout the view time.

Typically, the retardance in the low-voltage state is maintained at a particular value with the use of a small (2–4 volt rms) holding voltage. However, the effect of a holding voltage is to reduce the relaxation time to the half-wave retardance state. For instance, a particular modulator was found to have a 1.2 ms relaxation time (1.2 ms to go from, 10% transmission to 90% transmission between crossed polarizers) when operated with a 3 V rms holding voltage. The holding voltage was selected to provide the desired half-wave retardance throughout the 5.6 ms view time.

By using a three-level drive scheme, the relaxation time can be reduced. Initially, the modulator is switched from the maximum voltage state to a zero voltage state, which maximizes the relaxation to the half-wave state. After the desired retardance is achieved, the modulator can be driven with a small holding voltage for the remainder of the view time in order to maintain that retardance. The result is a 0.6 ms switching speed, corresponding to a 6% increase in throughput over that obtained with a two-level drive scheme.

In the four-polarizer multi-stage CSLM, neutral polarizers are inserted between each stage. Because the polarization is analyzed after each stage, the overall transmission is the product of the power transmission function of each stage. For this reason, a white state must be common to every stage. Note that this is not the case if dye based color polarizers are used rather than neutral polarizers. Unlike the two-polarizer case, cell chrominance of a stage in the white state does not effect the polarization introduced into other stages. This makes the filter less susceptible to color coordinate degradation from SA states and off-normal light. On the other hand, the addition of two polarizers does reduce overall throughput. Below we consider two four-polarizer examples; one using SO additive primary stages, the other using SO subtractive primary stages (or SA subtractive primary stages). We do not consider SA: additive primary stages, due to the poor color coordinates obtained.

#### Four-Polarizer DCS: SO Additive Primary

FIG. 23 shows a four-polarizer DCS with SO additive primary stages. The DCS comprises input polarizer 1450, red stage 1420, polarizer 1470, green stage 1430, polarizer 1480, blue stage 1440 and output polarizer 1490. In this embodiment, we again make generation of red, green, blue, and a high density black state the driving design objective, at the expense of the complementary states. The DCS is constructed using R/W, G/W and B/W SO additive primary stages. Because each stage has a SA white state with internal polarizers, we anticipate that the accumulation of the chromatic effects of the modulator will attenuate the white output. More importantly, because the filtering operation from each stage blocks two additive primaries, it is not feasible to generate the subtractive primaries at all using neutral polarizers. However, the stages are independent when additive primaries are generated, and it is possible to generate a high density black state. Thus, while this embodiment may not be preferred for subtractive display implementations, it can, for example, be used as a color sequencer.

Note that every primary color that is output is the product of the color generated by one stage, and the white state from

the remaining stages. In order to provide high throughput in the presence of significant modulator chrominance, it is necessary to tune the white state to provide maximum transmission at the center wavelength of the selected color. This affects the design of the modulators, since the half-wave retardance must be sufficient to provide a white state at the longest wavelength primary color that it accommodates. For example, the blue and green stages must give a half-wave retardance in the red, while the red stage must provide a half-wave retardance in the green.

There are additional benefits of tuning the white state. One benefit is the additional blocking provided by the low contrast filtering operations. For instance, additional blue rejection occurs from blue and green stages with their white states tuned to a red peak transmission. Conversely, the white state can be used in an analog mode to control color balance. A particular output primary color is substantially modulated by each of the other stages. As such, tuning the “white” stages from SA to SO modulates the desired output primary color between full:transmission and zero transmission.

Another benefit of using SO additive primaries is that it is possible to generate a high density black state. Because each filtered state effectively blocks two additive primaries, there is a great deal of redundancy when each stage is in the SO mode. In fact, each additive primary band is blocked by two stages. If the modulators are implemented with nematic LCs, which have asymmetric switching rates, the beneficial transient behavior discussed above in connection: with the two-polarizer DCS is exhibited. Specifically, the DCS can be driven rapidly to black, and the independence of stages provides high quality color coordinates during relaxation. Unlike the two-polarizer case, all three stages simultaneously generate additive primaries during the black output. The transmitted color is therefore determined by which combination of stages are switched to the white state. It is only the distortion of the transmission band caused by the evolution of the white states that can effect the color coordinate.

#### Four-Polarizer DCS: SO White

If the objective is to generate subtractive primaries, as is the case for certain electronic camera applications, the opposite of the above design considerations is true, except when a high density black state is also required. With parallel polarizers, cyan, magenta and yellow are generated independently by each of the three stages, and white can, in principle, be substantially lossless. However, the difficulty in obtaining a high density black state subtractively persists. Specifically, generation of the black state requires the cooperative action of C, M, and Y stages to achieve acceptable density. Even when cooperation between stages is optimized, the density of the black state is relatively poor. As such, the additive approach to producing subtractive primaries is usually preferred when a high density black state is required.

In this case, we obtain a DCS with behavior much like the two-polarizer SO subtractive primary DCS. Because each modulator modulates only one additive primary, the four-polarizer DCS can operate in either a SO subtractive or SO white mode with little difference in performance. The four-polarizer DCS is also suitable for implementing subtractive three-panel display systems.

Because the chromatic effects of the modulator are not significant, a high transmission white state can be generated in either SO subtractive primary or SO white modes. This

eliminates the need to tune a chromatic white state. Using this design scheme, high quality subtractive primaries can be generated as well. However, the additive primaries can suffer from non-ideal cooperation between stages. The symptoms are much like those found in the two-polarizer DCS, including a true cyan side lobe in the red output, a true yellow side-lobe in the blue output, and a black state with relatively poor density. However, the exact behavior is different because the output in the four-polarizer DCS is the product of the transmission function of each stage. This means, for example, that stages cannot interact to improve rejection in the interprimary bands.

FIG. 24 shows a four-polarizer DCS that generates a SO white state. The DCS comprises an input polarizer 1450, a red stage 1420, polarizer 1470, green stage 1430, polarizer 1480, blue stage 1440 and output polarizer 1490.

#### Field of View

Selection of the modulator and the CSLM configuration is typically influenced by the field of view (FOV) requirement for a particular application. The FOV requirement can have a significant influence on the CSLM design and the modulator selection. In complementary color polarizer based systems, such as polarizer retarder stack (PRS), approximately equal weight is assigned to the FOV of the two voltage states, because both voltage states have a role in generating filtered spectra. Conversely, a system based on white/primary CSLMs permits unequal weights to be assigned to the voltage states. Specifically, a CSLM stage can be biased to generate a fixed color coordinate at large incidence angles in the filtered state, at the expense of the viewing angle in the white state. This design works best when a polarizer separates each stage, because such stages interact on a power transmission basis.

A benefit of the CSLM's of the present invention is that the modulator retardance does not represent a color shift. This is because, the transition bandwidths are defined by the retarder stacks and are independent of the state of the modulator. The modulator functions as a valve that determines the extent to which the spectral window established by the passive retarder stacks is filled.

#### Wide FOV Four-Polarizer RGB CSLM

Consider a four-polarizer three-color CSLM designed to give maximum FOV, as is required for sequential electronic camera applications. For this type of application, the switching speed is not critical, but a fixed color coordinate is desirable. Consider a CSLM structure that utilizes antiparallel aligned ZTN modulators. An anti-parallel aligned nematic LC cell gives a large field of view in the undriven state, because it consists only of a zero-order uniaxial in-plane half-wave retardance. Accordingly, there is no first-order shift in retardance with off-normal angles. Conversely, the driven state has a z-dependent director distribution that is not self-compensating. As such, the LC cell provides better FOV performance in the undriven state when uncompensated.

As discussed above, an RGB four-polarizer CSLM gives the best color coordinates using the SO filtered mode. Using an antiparallel nematic LC cell for the modulator means that the filtered output is assigned to the driven state, which has an inferior FOV. This problem can be solved by passively inverting the states. This is preferably accomplished by combining a negative birefringence in-plane uniaxial retarder film with the antiparallel nematic LC cell. The negative birefringence in-plane uniaxial retarder film is

suitably polystyrene (Y. Fujimura et al, SID 92 Digest, p.397) or a styrene derivative (U.S. Pat. No. 5,430,565). It could also be a preimidized polyamide or a liquid crystal polymer (H. Mori et al., European SID 97, M88).

A negative birefringence uniaxial in-plane half-wave retarder film oriented parallel to the antiparallel nematic half-wave retarder optic axis gives zero net retardance, as long as the dispersions are matched. Furthermore, the compound structure maintains zero retardance to very large angles of incidence and for all azimuths. Thus, the undriven state is converted from a half-wave retarder, with some sensitivity to incidence angle, to a zero-retardance that is substantially less sensitive to incidence angle. This gives the desired preference to the quality of the undriven state for the filtering operation.

Using this configuration, the color coordinate established by a stage in the filtering state is only marginally affected by the quality of the white states generated by the other stages. It is only the chrominance of the white states within the primary band that can shift the color coordinate. The effect is mainly to reduce the transmission of the primary, as the retardance shifts away from the half-wave retardance at the center of the band. This shift is enhanced by the relatively poor FOV of the driven state, in addition to the zero-order in-plane half-wave retardance from the film. In most cases, the associated loss in efficiency is much less objectionable than a color shift.

FIG. 25 shows a wide field of view four-polarizer RGB-CSLM that utilizes an SO additive primary design. The CSLM comprises input polarizer 1450, red stage 1420, polarizer 1470, green stage 1430, polarizer 1480, blue stage 1440 and output polarizer 1490.

#### CSLM Materials

The retarder stacks can in principle be constructed of any transparent material that imparts differing optical path lengths to orthogonal polarizations. The typical range for color generation is 0.5–2.5 waves of visible retardance. Other desirable characteristics include low-cost, large area, uniform, thin, and durable under high illumination levels and harsh environments. Potential linear retarder technologies include form-birefringence structures, crystalline retarders, stretched polymer retarder sheets, and liquid crystal polymer films.

Form birefringence devices are based on periodic structures with features smaller than a wavelength. A grating with sufficiently high spatial frequency, for instance, does not diffract light from the zero order, and has optically distinct path lengths parallel and perpendicular to the grooves.

Conventional crystalline retarder materials, such as quartz, mica and calcite, are well suited to applications requiring higher resolution than is feasible with polymer films. They are also useful for applications requiring low wavefront distortion, and/or high power handling requirements. They are more expensive than polymer retarders and do not lend themselves to large area, particularly when low retardances are required.

Polymers are chemical compounds or mixtures of compounds consisting of repeating structural units formed by a chemical reaction, where two or more small molecules combine to form larger molecules. Retarders can be formed using sheets of oriented organic polymers. By unidirectional or bidirectional stretching of polymer films at elevated temperatures, a linear birefringence can be induced. For most materials, such as polyvinyl alcohol or polycarbonate, the refractive index increases in the direction of the stretch,

typically forming a positive in-plane uniaxial retarder. Materials such as polystyrene, and styrene derivatives (U.S. Pat. No. 5,430,565) give a negative in-plane birefringence after stretching. Such materials are useful for producing wide-view angle CSLM structures. Retardation films exhibiting fixed retardation with off-normal view angles are produced using one of two techniques, biaxial stretching or compound retarders. The combination of a positive uniaxial film crossed with a negative uniaxial film of equal retardation results in a compound retarder with an isotropic, angle-insensitive retardation (U.S. Pat. No. 5,138,474).

As an alternative, a single layer biaxial film with wide view angle can be fabricated using stretching along both x and z, as described in U.S. Pat. No. 5,245,456, U.S. Pat. No. 5,472,538, and U.S. Pat. No. 5,559,618. Such stretching can produce a biaxial film with a z direction refractive index that is substantially intermediate between the in-plane refractive indexes. This single film behaves much like the two-layer film in providing a large isotropic view angle.

Stretched polymer films are available in arbitrary retardances typically from 0–2,000 nm, using a variety of materials with unique birefringence dispersion characteristics. Large sheets can be purchased at low cost, permitting large clear aperture filters. Polycarbonate is the most common material for display applications and is available from vendors such as Nitto Denko, Sumitomo, and Sanritz. Other materials, such as poly-vinyl alcohol, can be purchased from Polaroid, Polarvision, Inc., and International Polarizer. High dispersion materials, such as polysulphone and polyarylate films, are available from Nitto Denko and Sumitomo. Several other polymer materials are potentially useful in producing stacks including, but not limited to, mylar, polyamide, polypropylene, polyethylene terephthalate, triacetate (tri-butyl-acetate), polytetrafluoroethylene, and polymethylmethacrylate.

As discussed above, spatially patterned CSLM structures, as for color filter arrays, can be implemented using spatially patterned polymer retarders. Here, a film with a spatially patterned retardation replaces or works in concert with the active LC element. Such patterned retarder films can be fabricated by locally stressing an isotropic polymer film. Half-wave retarder stripes can be patterned on an isotropic substrate by locally stressing a film.

Liquid Crystal Polymers (LCP) are a class of polymers wherein liquid crystal monomers are incorporated into the macromolecular structure along the mainchain (backbone) or as side chain units. LCP's can be aligned by either mechanically rubbed surfaces, shearing, or by optical means. Optical methods involve first applying either linear photo-polymerizable (LPP) films or azo-based dyes either in a polymer alignment layer.

If LPP films are used, (see Schadt, et al, Jpn. J. Appl. Phys. Vol. 34, pg. 3240–3249, 1995), the LPP materials are deposited on a substrate and then cured at elevated temperature. The cured film is then subjected to polarized UV light. LCP's are then spun-on or coated onto the same substrate, and aligned with the orientation of the LPP film. The LCP's are then cross-linked by exposure to unpolarized UV light.

If azo-based dyes are used, (Shannon et al, Nature, vol. 368, pg. 532–533, 1994), azo-dye molecules are intercalated into the polyimide alignment layer (or layers), which are deposited onto various substrates, e.g., glass, silicon, or others. A liquid crystalline monomer or polymer is either deposited onto one substrate, or sandwiched in between two substrates. The LC molecular director orients perpendicular to the direction of the polarized UV light which previously

illuminated the alignment layer. Subsequent exposure will reorient the liquid crystals, which may be disadvantageous for some applications.

Liquid crystal polymer films, particularly UV cross-linkable polymer nematic retarders, are particularly suitable for forming retarder stacks. An attractive feature is the ability to produce thin retarders, since the material can have high birefringence relative to stretched materials. This can permit the fabrication of multi-layer retarder stacks on a single substrate, such as the polarizer substrate, with low cost. Because the films can be patterned at arbitrary angles, there is no waste, as is the case when cutting stretched polymer films at angles. Each LCP layer can essentially be bonded to the previous layer, avoiding the need for applying pressure sensitive adhesives to each film. In addition, LCPs are conducive to forming complex impulse response retarder stacks, because the retardation of each LCP layer is arbitrary. Such a capability increases the degrees of freedom, which results in greater design options. Conversely, there are significant cost pressures to minimize the number of unique retardation values in each retarder stack when using stretched polymer films.

The retarder stacks discussed above preferably comprise discrete layers, i.e., individual retarders, with specific orientations and retardance values. However, continuous retarder “stacks” or structures can be fabricated using layers of LCP with twisted structures. Thus, the retarder stack is not limited to a discrete number of individual zero-twist Linear retarders. By selecting film thickness, birefringence, and the orientation of molecules at the boundary of each surface, films self-assemble into continuous retarder structures. Thin glass films can be formed on a substrate using LCP materials. Such films are equivalent to a large number of very thin individual linear retarders, but avoids the need to physically stack individual retarder layers. Other color options are available by stacking twisted LCP layers or twisted and zero-twist LCP layers.

Currently available LCP materials have a positive anisotropy. In order to produce a wide view angle LCP, a biaxial retarder is required. A single film would require a true biaxial LCP (P. Bladon et al., *Macromolecules*, 25, 4329 (1992)). An alternative is a two-layer compound retarder containing positive and negative birefringence LCPs. Yet another alternative is to take advantage of the out-of-plane tilt achievable with photoaligned LCP. By providing two identical parallel oriented LCP films with equal and opposite out-of-plane tilt angle, a compound retarder is formed with a view angle that is controlled by the tilt angle. At roughly 34-degrees, the off-normal dependence of retardation can be made to vanish in the plane containing the optic axis.

Because LCPs can be photoaligned, a spatially varying orientation, both in-plane and normal to the surface, can be achieved by photo-patterning. This is done using standard lithographic techniques. As such, spatially patterned versions of CSLM structures can be produced that behave as color filter arrays. Here, the active modulator of a CSLM is replaced by a spatially patterned LCP retarder that locally determines the transmitted color. In addition, hybrid structures using both spatially-switched and actively-switched layers can be incorporated. In one embodiment, patterned retarders are used in series with the active modulator, so that modulation between fixed spatial patterns can be accomplished using an LC modulator device with unpatterned electrodes.

Other LCP materials are potentially useful for either retarder stack materials or for increasing the view angle.

Discotic LCPs from Fuji and Nippon Oil Company are negative birefringence materials fabricated on a CTA substrate (H. Mori, *Jpn. J. Appl. Phys.*, 36, 1068, (1997)). Some of the Discotic LCPs have the unique property that the optic axis has a splayed orientation that approximates that of the active modulator. This is quite useful for compensating the select state of, for instance, a TN device.

Other useful materials for increasing view angle are negative birefringent films with optic axes oriented along z. For instance, the cellulose triacetate (CTA) substrate of typical iodine display polarizers has 40–76 nm of retardance normal to the substrate on either side of the polarizer. Larger retardances can be obtained by biaxial stretching of polymers, such as polycarbonate (Nitto Denko and Sumitomo). Typically, such films exhibit a small positive in-plane retardation. Other materials, such as preimided polyamide, are negative birefringent materials that align with their optic axis normal to the substrate, giving zero in-plane retardance.

Multiple films of negative birefringent film can be combined to form a composite structure that can fully compensate one state of the LC modulator. Preferred LC modulators, such as the pi-cell, are those in which the passive structure improves the view angle of both the select and non-select states. Often, however, compensation improves field of view of one state at the expense of the other. This represents an advantage of CSLM structures, because the state providing the largest view angle can be assigned to the filter state. The compromised state is thus the neutral state, which can be made to have little influence on the color coordinate.

In the embodiments described and shown, the CSLM is illustrated with linear polarizers. In general, they can be linear, circular or elliptical polarizers. They can be neutral, or can exploit a wavelength-dependent polarization. Polarizer materials are available in a number of forms, the selection of which depends upon the application requirements. Suitable polarizers include absorption-based, e.g., crystal dichroism long chain molecules of dye or iodine and oriented metal particles (Polarcor product, Corning, Inc.), polymer multilayers, e.g., DBEF product, 3M, Inc., birefringent, e.g., calcite or quartz-based Ahrens, Wollaston, Rochon, Nicol, or Glan polarizers, scatter polarizers using rough surfaces (Yamaguti) or LC in a polymer matrix, reflection, e.g., cholesteric LC, multilayers on 45-degree prisms, coated prismatic, and periodic structures, e.g., coated gratings, slits, wires, or oriented silver or copper particles (Polarcor product, Corning Inc.).

Dichroic sheet polarizers are thin, low cost, large area, are easily integrated, and can perform well at large angles. High efficiency iodine polarizers, such as Nitto Denko EG1225 are appropriate for low power applications. Durable high luminance polarizer films for projection are typically based on dye-stuff, e.g., Polatechno and Polaroid KE product, with reduced throughput (84%). For normal incidence, the polarizer density need not be dramatically higher than is theoretically feasible based on side-lobe leakages from the retarder stack. As such, density can be traded for increased throughput if the polarizer technology permits.

In wide view-angle applications, polarizer FOV must be considered. Light leakages in the  $\pm\pi/4$  azimuths, relative to the polarizer axis, are most pronounced. Due to geometrical effects, crossed polarizers cease to appear crossed in these azimuths at off-normal incidence. In addition, substrate retardance can contribute to a loss in density. Based on these considerations, polarizers such as HN22 (Polaroid), which

exhibit high density and use a cellulose acetate butyrate (CAB) substrate, are preferred for large incidence angles. Methods for compensating geometrical effects and substrate retardance effects can also be implemented (J. Chen et al., *SID '98 Digest*, 315–318).

CSLM structures can be fabricated using techniques that are standard to the industry. Liquid crystal cells (modulators) are preferably fabricated using float glass or borosilicate glass panels, though plastic cells are also suitable. Borosilicate, such as Corning 7059, provides higher transmission than certain float glasses. The glass is coated with a transparent conductor for addressing the liquid crystal. A good conductor is indium tin oxide (ITO), typically with a resistivity of 100–1,000  $\Omega/\text{cm}^2$ . By coating oxide films between the glass and the ITO, such as  $\text{Ta}_2\text{O}_5/\text{MgF}_2/\text{ITO}$ , reflection losses can be minimized. In so doing, modulator transmission can be increased by several percent, often yielding upwards of 99% transmission.

An alignment layer is coated on the transparent conductor for orienting the LC film. Standard materials are polyimides, such as those from Nissan Chemical, though photoalignment materials (LPP) can also be used. The former is mechanically rubbed after processing, while the latter is exposed to UV light.

An adhesive gasket is dispensed or screen printed, typically with a 0.5–1.5 mm width around the perimeter of the cell, leaving a small fill hole. The glass substrates are mated and the adhesive is cured under pressure using either UV light, temperature, or a sequence of both. Spacers of glass rods or spheres, or flexible polymer balls are used to determine the spacing between conductors. Requirements for spacer density depend upon uniformity requirements, glass thickness/flatness, aperture size, and liquid crystal EO effect. Subsequently, the panel is broken into sticks for filling. The liquid crystal material is back-filled in the space between the conductors, and aligns according to the surface treatment used. In some cases, a filled part undergoes a post processing step to improve uniformity. The fill hole is then plugged using an adhesive. Contact is made to the ITO along one or two ledges (depending upon whether cross-over dots are used). Conductors typically include soldered wires, or pins.

Preferred retarder stacks are constructed from biaxial polycarbonate films and, when needed, neutral polarizer films. Typically, vendors supply both polarizer and retarder materials, and are therefore capable of building the complete retarder stack. Using pressure sensitive adhesives (PSAs), the complete retarder stack can be laminated together into a single unit, which is supplied with a protective layer on the polarizer and a release sheet on the retarder PSA. The retarder stacks can also be supplied die-cut to the appropriate product size.

Retarder stacks can be applied to the external surfaces of the LC modulator using the PSA, forming a single CSLM stage. Multiple stage CSLMs can be fabricated by cementing the stages together using standard materials. These includes UV, thermal, pressure cure epoxies, RTVs, and an adhesive gasket material with a back-filled index matching material. Should plastic LC devices be used for the modulator, the entire CSLM can be fabricated using lamination techniques with PSAs. Wavefront distortion of the assembled unit can be compromised by the texture of the external polymer surfaces. This problem is greatly alleviated by cementing a glass end-cap over the external polymer surface. Furthermore, transmission can be improved by using an end-cap which is antireflection coated.

Transmission losses in retarder stacks are the result of several loss mechanisms. Typically, the retarder stacks are comprised of several sheets of polycarbonate with acrylic based PSA's between them. Losses are thus a consequence of material absorption and random scatter, as well as reflections at the interface between each PSA and polycarbonate layer. Reflection at the interface between each PSA and polycarbonate layer is typically dominant, as PSA material often has a refractive index far below that of the polycarbonate. Thus, methods for increasing transmission focus on eliminating surface reflections. One method of eliminating surface reflections is to use a PSA that is better matched to the polycarbonate refractive index. Another method is to use chemical bonding. In chemical bonding, the polycarbonate sheets are welded together using a suitable solvent. For example, polycarbonate dissolved in methylene chloride provides an index matched material.

#### Color Display Modes

As discussed above, there are generally four ways to implement color displays: (1) spatial; (2) sequential; (3) split-path; and (4) common-path. The CSLM can be used purely as a color sequencer in a sequential architecture, or can be used to implement a common-path display in a stacked-panel architecture. In addition, hybrid architectures can be implemented that use CSLM devices in displays that combine any of the above four color generation techniques.

FIG. 26 is a table listing 18 examples of display types, that can utilize CSLM technology in either a common-path or sequential capacity. When using two or less display panels, it becomes necessary to resort to either spatial, sequential, or both in order to display full-color. When the number of displays is three or more, it is not necessary, though it is still possible, to use spatial or sequential techniques. Many such examples are therefore omitted from the table.

##### (A) Sequential Color Display

A full color sequential display (design #2 in FIG. 23) is implemented using a single image engine, operating at three times the composite system frame rate, synchronized with three-color illumination.

FIG. 27 shows a full color sequential display implemented with a transmissive liquid crystal display, and utilizing the digital color sequencer of the present invention. The sequential display comprises a light source 1500, a two-polarizer digital color sequencer 1550, a transmissive pixelized liquid crystal display 1560, a polarizer 1570, a projection lens 1580 and a display screen 1590.

The light source 1500 is suitably a metal halide lamp and preferably emits optical power in all three primary color bands. Alternatively, the light source 1500 can be implemented with an active lamp system or with a lamp/color wheel combination.

For illustrative purposes, the two-polarizer digital polarizer color sequencer 1550 is of the type shown in FIG. 18. The digital color sequencer 1550 comprises an input polarizer 1450, a blue stage 1420, a green stage 1430 and red stage 1440.

The blue stage 1420 comprises a first retarder stack 1470, a blue LC modulator 1480 and second retarder stack 1490. The green stage 1430 comprises a first retarder stack 1500, an LC modulator 1510 and a second retarder stack 1520. The red stage 1440 comprises a first retarder stack 1530, an LC modulator 1540 and a second retarder stack 1550. The input and output polarizer 1450 and 1460 are crossed.

In operation, the light source 1500 and the sequencer 1550 sequentially illuminates the liquid crystal display 1560 with red green and blue light. The liquid crystal display 1560 is

sequentially driven with red green and blue image information in synchronism with the red green and blue illumination from the light source 1500 and the color sequencer 1550. The liquid crystal display 1560, in combination with the polarizer 1570, modulates the intensity of the light that is sent to the screen 1590 in accordance with the image information. The full color sequential display of FIG. 24 can be implemented as a front projection display, in which the screen 1590 is viewed from the same side as the projection optics, or as a rear projection display, in which the screen 1590 is viewed from the side opposite the projection optics.

FIG. 28 shows a full color sequential display using a reflective liquid crystal display, and utilizing the digital color sequencer of the present invention. The display of FIG. 25 is similar to the display shown in FIG. 24, except that a reflective liquid display 1600 is used instead of a transmissive liquid crystal display. In this configuration, a polarizing beam splitter 1610 is used as both as the output polarizer for the digital color sequencer and as the input/output polarizer for the reflective liquid crystal display 1600. Thus, the polarizing beam splitter 1610 reflects light whose polarization is crossed with respect to the polarization axis of the input polarizer 1450. In operation, light that passes through the blue green and red stages 1420, 1430 and 1440 is reflected by the polarizing beam splitter 1610 to the reflective liquid crystal display 1600. The reflective liquid crystal display 1600 polarization modulates the light in accordance with the image information and reflects the polarization modulated light back towards the polarizing beam splitter 1610. The polarizing beam splitter 1610 passes components of the light reflected from the liquid crystal display 1600 that are orthogonally polarized with respect to the light that was reflected from the polarizing beam splitter 1610 towards the liquid display 1600. Accordingly, image information is displayed on the screen 1590.

As discussed above, other types of illumination systems can be used in place of the light source 1500 in the displays of FIGS. 24 and 25. For example, lamps or light emitting diodes can be packaged which function as true color sequential sources. In a three-lamp system, it is difficult to obtain red and green phosphorous with a rapid decay. One solution is to use a lamp system in combination with the CSLM of the present invention in order to eliminate color cross-talk between frames, as required in OCB mode displays.

In the display shown in FIGS. 24 and 25, the digital color sequencer is positioned between the light source 1500 and the liquid crystal displays (1560 in FIG. 24 and 1600) in FIG. 25). However, the digital color sequencer 1550 can be positioned at other locations in the display system, provided that effectively controls the illuminating color at the output, i.e., the screen 1590.

By placing the digital color sequencer between the light source 1500 and the liquid crystal display 1560 or 1600, the image at the screen 1590 is not sensitive to any wave-front distortion caused by the digital color sequencer 1550.

The digital color sequencers 1550 can be made relatively small, even though the power handling is relatively high when the digital color sequencer 1550 is positioned as shown in FIGS. 24 and 25. UV and IR filtering (not shown) is preferably inserted between the light source 1500 and the digital color sequencer 1550.

Alternative locations for the digital color sequencer 1550 are between the liquid crystal display 1560 or 1600 and the projection lens 1580, and between the projection lens 1580 and the viewing screen 1590. If the digital color sequencer 1550 is located between the projection lens 1580 and the viewing screen 1590, the digital color sequencer 1550 must

have a relatively large clear aperture and low wave-front distortion. In addition, this location will reduce the power handling requirements of the digital color sequencer.

For a high-frame rate system, the LC display **1560** or **1600** is preferably a silicon-based display, rather than a TFT. Typical reflective LCDs integrate ferroelectric LC, or a variety of nematic LC modes, between a glass substrate coated with a solid ITO electrode and a reflective active matrix structure on a silicon substrate. In such systems, the analyzing polarizer of the DCS **1550** can serve as the input polarizer to the LCD panel, or vice versa. In a system that uses off-normal illumination, such as a DMD the sequencer can be placed in either the illumination or projection arms of the system. However, in a retroreflecting arrangement, a beam splitting polarizer functions both to create a crossed polarizer and to route the beam through the system. In such a configuration, the sequencer can also be inserted in the arm between the beam splitting polarizer and the LCD. However, additional constraints are imposed on the design of such a CSLM based color sequencer.

The foregoing embodiments are merely exemplary and are not to be construed as limiting the present invention. The present teaching can be readily applied to other types of apparatuses. The description of the present invention is intended to be illustrative, and not to limit the scope of the claims. Many alternatives, modifications, and variations will be apparent to those skilled in the art. In the claims, means-plus-function clauses are intended to cover the structures described herein as performing the recited function and not only structural equivalents but also equivalent structures.

What is claimed is:

**1.** A light modulator, comprising:

an input polarizer for receiving input light and outputting polarized light;

a first color selective polarization modulator for receiving said polarized light and for selectively modulating the polarization state of at least a first spectrum of said polarized light;

a second color selective polarization modulator for receiving light from said first color selective polarization modulator, and for selectively modulating the polarization state of at least a second spectrum of said polarized light; and

an output polarizer for receiving and analyzing the polarization states of said first and second spectrums, wherein the input polarizer, the color selective polarization modulators and the output polarizer are optically coupled.

**2.** A light modulator, comprising:

a retarder stack for receiving at least partially polarized light and outputting a first spectrum having a first polarization and a second spectrum having a second polarization; and

an electro-optic modulator and retarder combination optically coupled to the retarder stack and having an isotropic state and a modulation state, wherein the electro-optic modulator and retarder combination is adapted to selectively modulate input light that has a polarization state that corresponds to the modulation state of the electro-optic modulator and retarder combination, wherein one of the first and second polarizations correspond to the modulation state of the electro-optic modulator and retarder combination.

**3.** The light modulator of claim **2**, wherein the first and second polarizations output by the retarder stack are linear polarizations.

**4.** The light modulator of claim **2**, wherein the electro-optic modulator and retarder combination comprises a variable retarder in combination with a passive quarter-wave retarder.

**5.** The light modulator of claim **4**, wherein the modulation state is a linear polarization state and the isotropic state is a circular polarization state.

**6.** A sequencer, comprising:

a first modulator stage, comprising:

a first input retarder stack for receiving and transforming the polarization of light,

a first electro-optic modulator for receiving and selectively modulating the polarization of a portion of light output by the first retarder stack, and

a first output retarder stack for receiving and transforming the polarization of light output by the first electro-optic modulator;

a second modulator stage, comprising:

a second input retarder stack for receiving and transforming the polarization of light,

a second electro-optic modulator for receiving and selectively modulating the polarization of a portion of light output by the second retarder stack, and

a second output retarder stack for receiving and transforming the polarization of light output by the second electro-optic modulator; and

a third modulator stage, comprising:

a third input retarder stack for receiving and transforming the polarization of light,

a third electro-optic modulator for receiving and selectively modulating the polarization of a portion of light output by the third retarder stack, and

a third output retarder stack for receiving and transforming the polarization of light output by the third electro-optic modulator.

**7.** The sequencer of claim **6**, wherein the first, second and third modulator stages function substantially independent of each other.

**8.** The sequencer of claim **6**, wherein the first, second and third electro-optic modulators exhibit higher chromaticity in a stack-altered mode than in a stack-only mode.

**9.** The sequencer of claim **8**, wherein the first, second and third modulator stages each exhibit a filtered state and a neutral state when their respective electro-optic modulators are in the stack-altered mode and the stack-only mode, respectively.

**10.** The sequencer of claim **9**, wherein the neutral state is a black state.

**11.** The sequencer of claim **9**, wherein the neutral spectrum is a white state.

**12.** The sequencer of claim **8**, wherein the first, second and third modulator stages each exhibit a filtered state and a neutral state when their respective electro-optic modulators are in the stack-only mode and the stack-altered mode, respectively.

**13.** The sequencer of claim **12**, wherein the neutral state is a black state.

**14.** The sequencer of claim **12**, wherein the neutral state is a white state.

**15.** The sequencer of claim **6**, wherein a state of each of the first, second and third modulator stages is switchable between one additive primary filtered state and a neutral state.

**16.** The sequencer of claim **15**, wherein the state of the first, second and third modulator stages is switchable between red and black states, green and black states, and blue and black states, respectively.

17. The sequencer of claim 6, wherein a state of each of the first, second and third modulator stages is switchable between one subtractive primary filtered state and a neutral state.

18. The sequencer of claim 17, wherein the state of the first, second and third modulator stages is switchable between cyan and white states, magenta and white states, and yellow and white states, respectively.

19. The sequencer of claim 6, wherein a peak transmission of one of said first, second and third modulator stages is tunable so that its peak transmission coincides with a peak transmission of a respective filtered state.

20. The sequencer of claim 6, wherein the first, second and third electro-optic modulators exhibit higher chromaticity in a stack-only mode than in a stack-altered mode.

21. The sequencer of claim 20, wherein the first, second and third modulator stages each exhibit a filtered state and a neutral state when their respective electro-optic modulators are in the stack-altered mode and the stack-only mode, respectively.

22. The sequencer of claim 21, wherein the neutral state is a black state.

23. The sequencer of claim 21, wherein the neutral state is a white state.

24. The sequencer of claim 20, wherein the first, second and third modulator stages each exhibit a filtered state and a neutral state when their respective electro-optic modulators are in the stack-only mode and the stack-altered mode, respectively.

25. The sequencer of claim 24, wherein the neutral state is a black state.

26. The sequencer of claim 24, wherein the neutral state is a white state.

27. The sequencer of claim 6, wherein the first input retarder stack is an inverse of the first output retarder stack.

28. The sequencer of claim 6, wherein the second input retarder stack is an inverse of the second output retarder stack.

29. The sequencer of claim 6, wherein the third input retarder stack is an inverse of the third output retarder stack.

30. The sequencer of claim 6, wherein the first, second and third input retarder stacks are inverses of the first, second and third output retarder stacks, respectively.

31. The sequencer of claim 6, wherein the first, second and third modulator stages together exhibit a neutral state in the stack-altered mode.

32. The sequencer of claim 31, wherein the neutral state is a white state.

33. The sequencer of claim 31, wherein the neutral state is a black state.

34. The sequencer of claim 31, wherein the polarization of input light received by the first modulator stage and the polarization of light output by the first modulator stage are matched.

35. The sequencer of claim 34, wherein the polarization of the input light is an eigenpolarization of the first modulator stage in the stack-altered mode.

36. The sequencer of claim 6, further comprising an analyzing polarizer positioned and oriented to receive and analyze light from the first, second and third modulator stages.

37. The sequencer of claim 36, wherein the first, second and third modulator stages each modulate the transmission of a respective spectrum between substantially full transmission and substantially zero transmission.

38. A multi-stage in-line color filter, comprising:  
a first stage for modulating a first spectrum in accordance with a first signal;

a second stage for modulating a second spectrum in accordance with a second signal;

a third stage for modulating a third spectrum in accordance with a third signal, wherein at least one of the first, second and third stages comprises a first retarder stack, a second retarder stack and a modulator positioned between the first and second retarder stacks, and wherein the modulator has an isotropic state and a modulation state, and wherein the first retarder stack modulates a polarization state of its respective spectra so as to correspond to the modulation state of the modulator; and

an output polarizer.

39. The multi-stage in-line color filter of claim 38, wherein the first, second and third stages do not include any interposing polarizers.

40. The multi-stage in-line color filter of claim 39, wherein the first, second and third stages modulate the polarization of the first, second and third spectrums, respectively, in accordance with the first, second and third signals, respectively.

41. The multi-stage in-line color filter of claim 38, wherein the first, second and third stages modulate the transmittance of the first, second and third spectrums, respectively.

42. The multi-stage in-line color filter of claim 41, wherein the transmittance of the first, second and third spectrums is continuously variable in accordance with the first, second and third signals, respectively.

43. The multi-stage in-line color filter of claim 38, wherein the first, second and third stages are each variable saturation filters.

44. The multi-stage in-line color filter of claim 38, wherein the first, second and third stages are each variable luminance filters.

45. A method of modulating light with a variable retarder using retarder stacks for transforming light into two linear polarization states with two spectra, comprising the steps of:

arranging a first retarder stack which yields a first and second linear polarization with first and second spectra;

arranging a retarder which transforms the second linear polarization into elliptical polarization; and

arranging a variable retarder to receive the elliptical polarization and the first polarization.

46. The method of claim 45, wherein the elliptical polarization is circular polarization, and the second polarization is linear polarization.

47. The method of claim 45, wherein the elliptical polarization is a modulation state for the variable retarder.

48. The light modulator of claim 2, wherein the retarder stack comprises retarders welded together by chemical bonding.

49. The light modulator of claim 48, wherein the welded retarders are polycarbonate sheets.

50. The light modulator of claim 49, wherein the welded retarders are welded together using methylene chloride.

51. The light modulator of claim 50, wherein a dope is formed of polycarbonate dissolved in methylene chloride.

52. The sequencer of claim 6, wherein at least one of the first input retarder stack, the second input retarder stack, the third input retarder stack, the first output retarder stack, the second output retarder stack, and the third output retarder stack comprises retarders welded together by chemical bonding.

53. The sequencer of claim 52, wherein the welded retarders are polycarbonate sheets.

43

54. The sequencer of claim 53, wherein the welded retarders are welded together using methylene chloride.

55. The sequencer of claim 54, wherein a dope is formed of polycarbonate dissolved in methylene chloride.

56. The multi-stage in-line color filter of claim 38, wherein at least one of the first stage, the second stage, and the third stage comprises a retarder stack, the retarder stack comprises retarders welded together by chemical bonding.

57. The multi-stage in-line color filter of claim 56, wherein the welded retarders are polycarbonate sheets.

58. The multi-stage in-line color filter of claim 57, wherein the welded retarders are welded together using methylene chloride.

59. The multi-stage in-line filter of claim 58, wherein a dope is formed of polycarbonate dissolved in methylene chloride.

60. The method of claim 45, wherein the first retarder stack comprises retarders welded together by chemical bonding.

61. The method of claim 60, wherein the welded retarders are polycarbonate sheets.

44

62. The method of claim 61, wherein the welded retarders are welded together using methylene chloride.

63. The method of claim 62, wherein a dope is formed of polycarbonate dissolved in methylene chloride.

64. A multi-stage in-line color filter, comprising:

a first stage for modulating a first spectrum in accordance with a first signal;

a second stage for modulating a second spectrum in accordance with a second signal;

a third stage for modulating a third spectrum in accordance with a third signal wherein at least one of the first, second and third stages comprises a first retarder stack, a second retarder stack and a modulator positioned between the first and second retarder stacks, and wherein the first, second and third stages do not include any interposing polarizers; and an output polarizer.

\* \* \* \* \*