



US006749310B2

(12) **United States Patent**  
**Pohlert et al.**

(10) **Patent No.:** **US 6,749,310 B2**  
(45) **Date of Patent:** **Jun. 15, 2004**

(54) **WIDE AREA LIGHTING EFFECTS SYSTEM**

(75) Inventors: **Rudy G. Pohlert**, Calabasas, CA (US);  
**Pat Grosswendt**, Agoura, CA (US)

(73) Assignee: **Contrast Lighting Services, Inc.**,  
Calabasas, CA (US)

(\*) Notice: Subject to any disclaimer, the term of this patent is extended or adjusted under 35 U.S.C. 154(b) by 91 days.

(21) Appl. No.: **09/949,206**

(22) Filed: **Sep. 7, 2001**

(65) **Prior Publication Data**

US 2002/0044435 A1 Apr. 18, 2002

(51) **Int. Cl.**<sup>7</sup> ..... **G03B 13/02**

(52) **U.S. Cl.** ..... **362/11; 362/8; 362/13;**  
**362/295; 396/182**

(58) **Field of Search** ..... **362/3, 8, 11, 13,**  
**362/295; 396/155, 182**

(56) **References Cited**

**U.S. PATENT DOCUMENTS**

2,682,603 A	6/1954	Dine et al. ....	240/1.3
3,794,828 A	2/1974	Arpino .....	240/4.2
4,019,042 A	4/1977	Baliozian .....	240/1.3
4,085,436 A	4/1978	Weiss .....	362/16
4,469,418 A	9/1984	Stevens et al. ....	354/63
4,816,854 A	3/1989	Tsuji et al. ....	354/413
4,893,223 A	1/1990	Arnold .....	362/252
4,931,866 A	6/1990	Charlesworth et al. ....	358/93
5,010,412 A	* 4/1991	Garriss .....	396/155
5,038,258 A	8/1991	Koch et al. ....	362/237
5,187,611 A	2/1993	White et al. ....	359/599
5,235,497 A	8/1993	Costa .....	362/224
5,301,402 A	4/1994	Noel et al. ....	29/4
5,345,284 A	9/1994	Tsuruta .....	354/132
5,450,291 A	9/1995	Kumagai .....	362/3
5,461,417 A	10/1995	White et al. ....	348/131
5,539,485 A	7/1996	White .....	354/76
5,569,983 A	10/1996	McGuire et al. ....	315/297

5,580,163 A	12/1996	Johnson, II .....	362/285
5,604,550 A	2/1997	White .....	396/429
5,684,530 A	11/1997	White .....	348/131
5,690,417 A	11/1997	Polidor et al. ....	362/244
5,713,661 A	2/1998	White .....	362/355
5,808,295 A	9/1998	Takeda et al. ....	250/216

(List continued on next page.)

**FOREIGN PATENT DOCUMENTS**

DE	200 08 703 U1	9/2000
EP	1 072 884	1/2001
JP	09033445	2/1997

**OTHER PUBLICATIONS**

Millerson, Gerald, *Lighting For Television And Film*, Chapter 5, "Lighting people," pp. 96-139, no publication date.  
Millerson, Gerald, *Lighting For Television And Film*, Chapter 10, "Lighting equipment," pp. 295-350, no publication date.

Carlson, Vern et al., *Professional Lighting Handbook*, pp. 15-40, no publication date.

(List continued on next page.)

*Primary Examiner*—Stephen F. Husar

(74) *Attorney, Agent, or Firm*—Irell & Manella LLP

(57) **ABSTRACT**

A system and method for providing lighting effects comprises an arrangement of low power lights mounted on a frame having an opening through which a camera can protrude. In one embodiment, light-emitting diodes (LEDs) or light-emitting crystals (LECs) are arranged on the frame in a pattern of concentric circles, with the frame being ring-shaped and having a circular opening through which a camera can protrude, and a mounting bracket and assembly for attaching the frame to a camera. The LEDs or LECs may be electronically controllable so as to provide differing intensity levels, either collectively, individually, or in designated groups, and may be strobed, dimmed or otherwise controlled according to manually selected or programmable patterns.

**24 Claims, 17 Drawing Sheets**

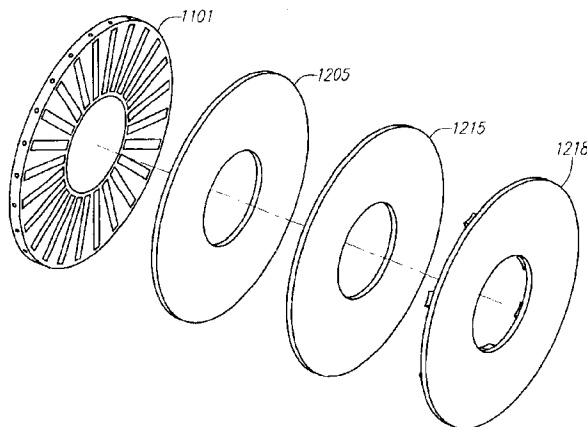

## U.S. PATENT DOCUMENTS

5,897,195	A	4/1999	Choate .....	362/33
6,016,038	A	1/2000	Mueller et al. ....	315/291
6,066,861	A	5/2000	Hohn et al. ....	257/99
6,149,283	A	11/2000	Conway et al. ....	362/236
6,150,774	A	11/2000	Mueller et al. ....	315/291
6,166,496	A	12/2000	Lys et al. ....	315/316
6,211,626	B1	4/2001	Lys et al. ....	315/291
6,252,254	B1	6/2001	Soules et al. ....	257/89
6,292,901	B1	9/2001	Lys et al. ....	713/300
6,340,868	B1	1/2002	Lys et al. ....	315/185
6,454,437	B1	9/2002	Kelly .....	362/246
2001/0010760	A1	8/2001	Saito .....	396/16
2002/0003602	A1	1/2002	Burckhardt .....	351/57
2002/0048169	A1	4/2002	Dowling et al. ....	362/234
2002/0048177	A1	4/2002	Rahm et al. ....	362/555
2002/0057061	A1	5/2002	Mueller et al. ....	315/291
2002/0084952	A1	7/2002	Morley et al. ....	345/32
2002/0110000	A1	8/2002	Marcus .....	362/555

## OTHER PUBLICATIONS

Nikon TTL Macro Speedlight SB-29 product sheet (undated).

“Photographic Projects . . . Gene F. Rhodes . . Feb. 6, 2002,” website printout from [www.photoprojects.net/](http://www.photoprojects.net/) (Jan. 14, 2001).

“Special Lighting Nov. 13, 2001 . . . home,” website printout from [www.photoprojects.net/index8.html](http://www.photoprojects.net/index8.html) (Nov. 13, 2001).

“NERLITE Ring Illuminators,” website printout from [www.nerlite.com/products/ring.html](http://www.nerlite.com/products/ring.html) (undated).

NETLITE R-100 Series product information sheet (Jan. 30, 2002).

NERLITE R-70 plus Series Ring Illuminators product information sheet (Nov. 9, 2001).

NERLITE AR-100 Series Area Array Illuminators product information sheet (Nov. 15, 2001).

Edmund Industrial Optics, website printout from [www.edmundoptics.com/IOD/DisplayProduct.cf?productid=1538](http://www.edmundoptics.com/IOD/DisplayProduct.cf?productid=1538) (undated).

“Ringlichtsystem für Fotografie und Mikroskopie,” website printout from [www.dentic.de/lite/ledlite.htm](http://www.dentic.de/lite/ledlite.htm) (in German) (undated).

“Makroaufnahmen so leicht wie noch nie,” website printout from [www.digitalkamera.de/info/News/09/51.de.htm](http://www.digitalkamera.de/info/News/09/51.de.htm) (in German) (Jul. 25, 2001).

“Imaging One bringt Makroblitz—Adapter für Nikon Coolpix 950/990,” website printout from [www.digitalkamera.de/info/news/08/22-de.htm](http://www.digitalkamera.de/info/news/08/22-de.htm) (in German) (Apr. 9, 2001).

“LED There Be Light,” 4 pages, printed on Aug. 8, 2002.

“Kamio Ring Light,” product brochure from [www.kinoflo.com](http://www.kinoflo.com), printed on Aug. 9, 2002.

“Luminaries” catalog excerpt, website printout from [http://www.artisticlicence.com/cat1\\_1.htm](http://www.artisticlicence.com/cat1_1.htm) (undated).

“Water-Fill WF 250 (WF250N)” brochure, Artistic License (UK) Ltd. (undated).

“Color-Fill Technology” press release, Artistic License (UK) Ltd. (undated).

“MultiMedia Quick Views,” Color Kinetics Inc., 2002.

“Chromacore in the beginning . . . ,” Color Kinetics Inc., 2002.

“Chromacore the digital lighting fixture,” Color Kinetics Inc., 2002.

“Chromacore puttin’ it all together,” Color Kinetics Inc., 2002.

“Chromacore a more colorful world,” Color Kinetics Inc., 2002.

“Products beauty, brains, and sensibility to boot!,” website printout from <http://pro.colorkinetics.com/products/>, Color Kinetics Inc., 2002.

“ChromaRange,” website printout from <http://www.pulsarlight.com/ChromaRange.htm>, Pulsar Light of Cambridge Ltd., 2000.

“White LED Clusters or Arrays, 12VDC Dimmers and 5mm LED Reflectors,” website printout from <http://www.theledlight.com/led-assemblies.html>, AmericaWorks/The LED Light 1997-2000.

\* cited by examiner

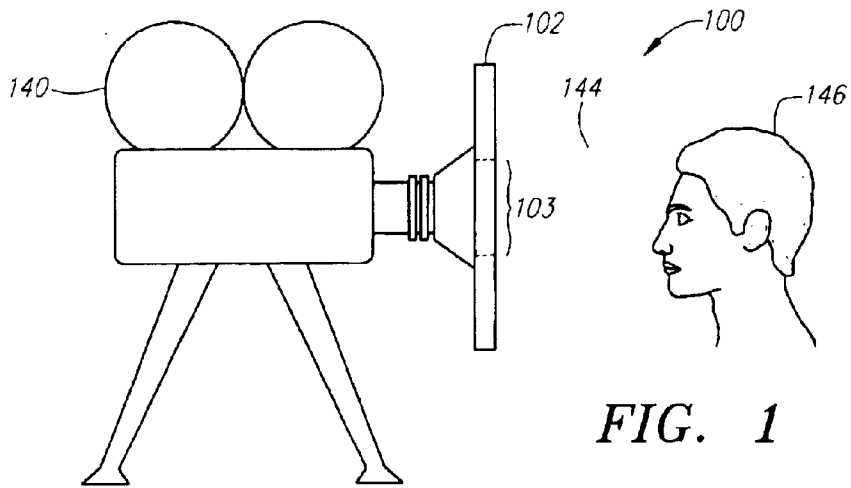

FIG. 1

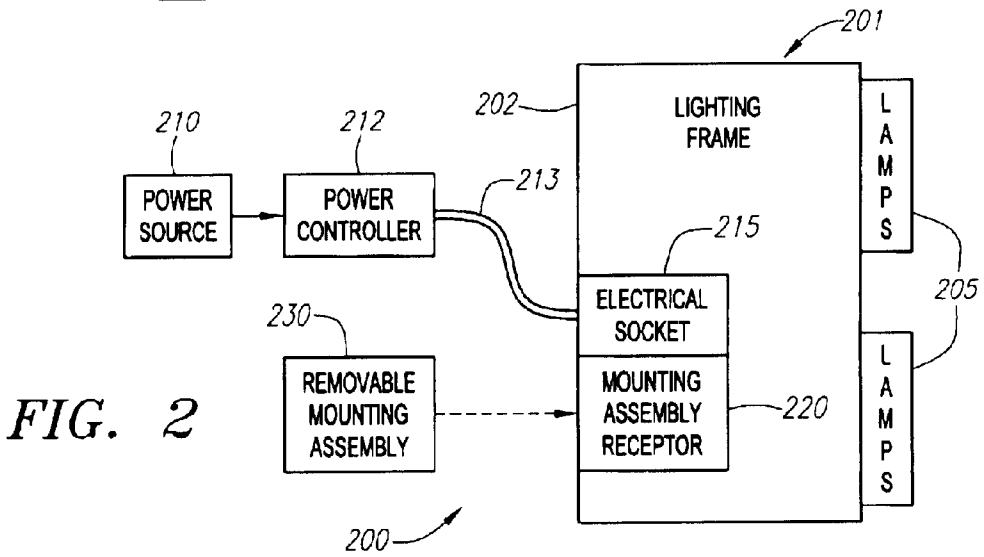

FIG. 2

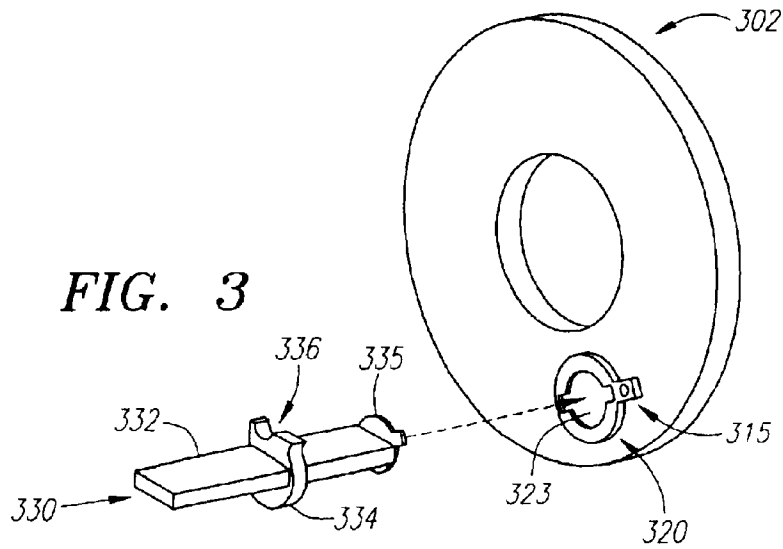

FIG. 3

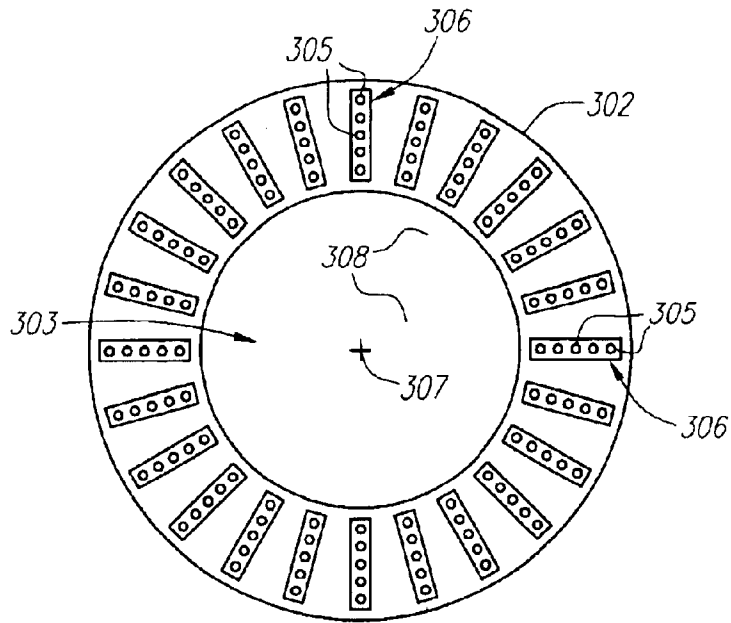

FIG. 4

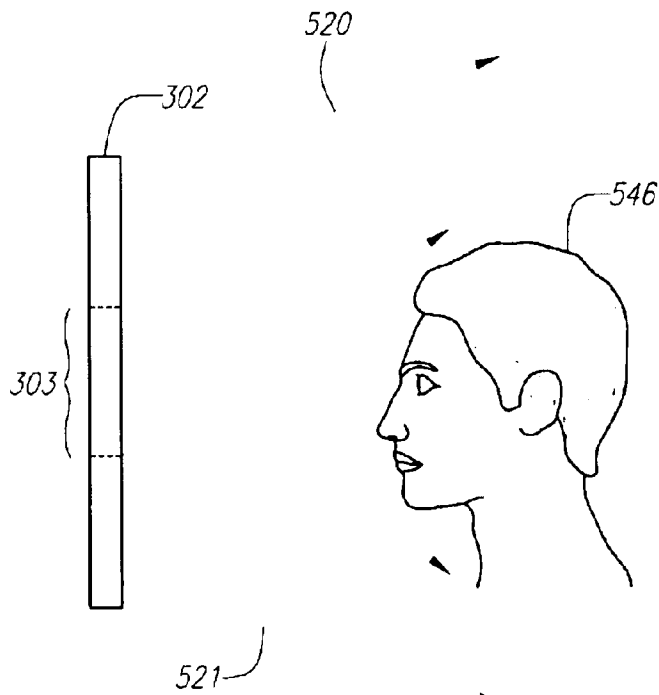

FIG. 5

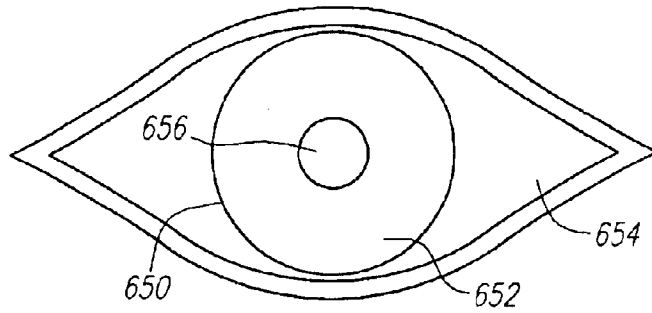

FIG. 6

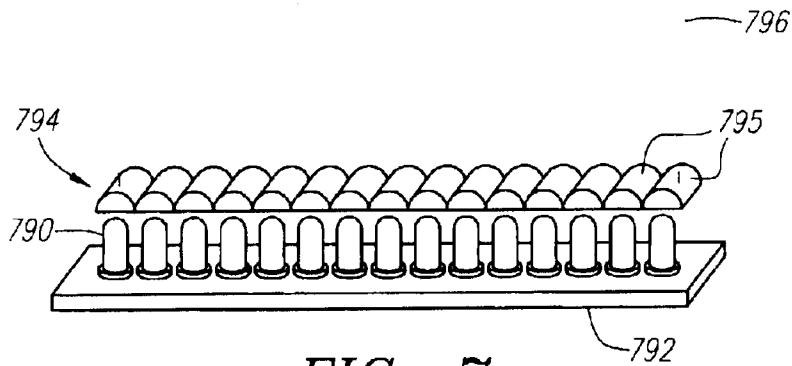

FIG. 7

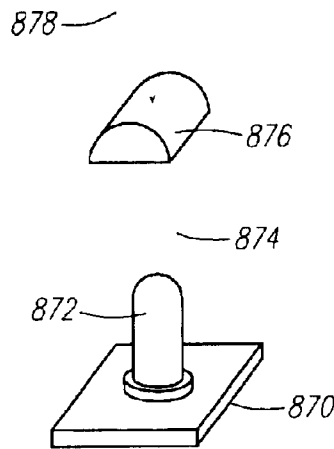

FIG. 8

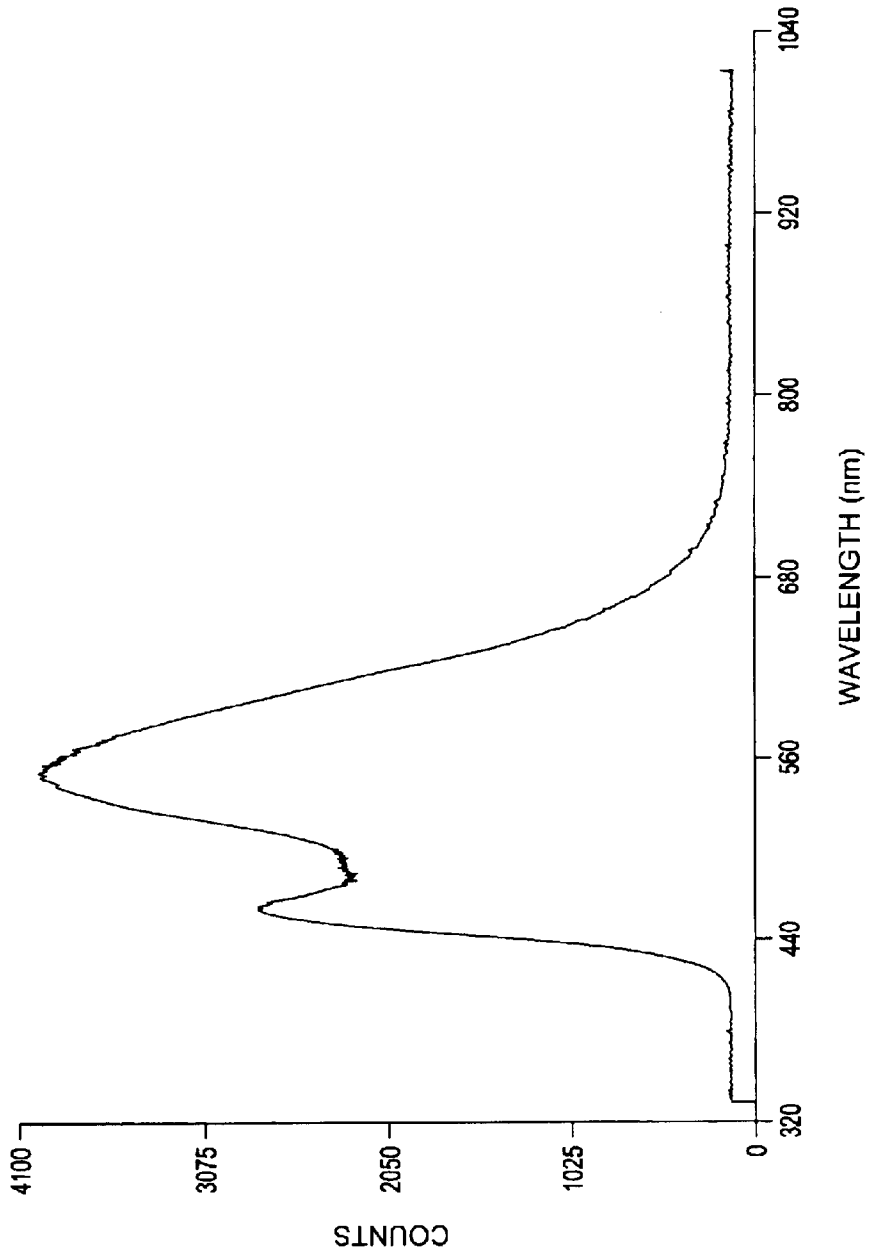

FIG. 9

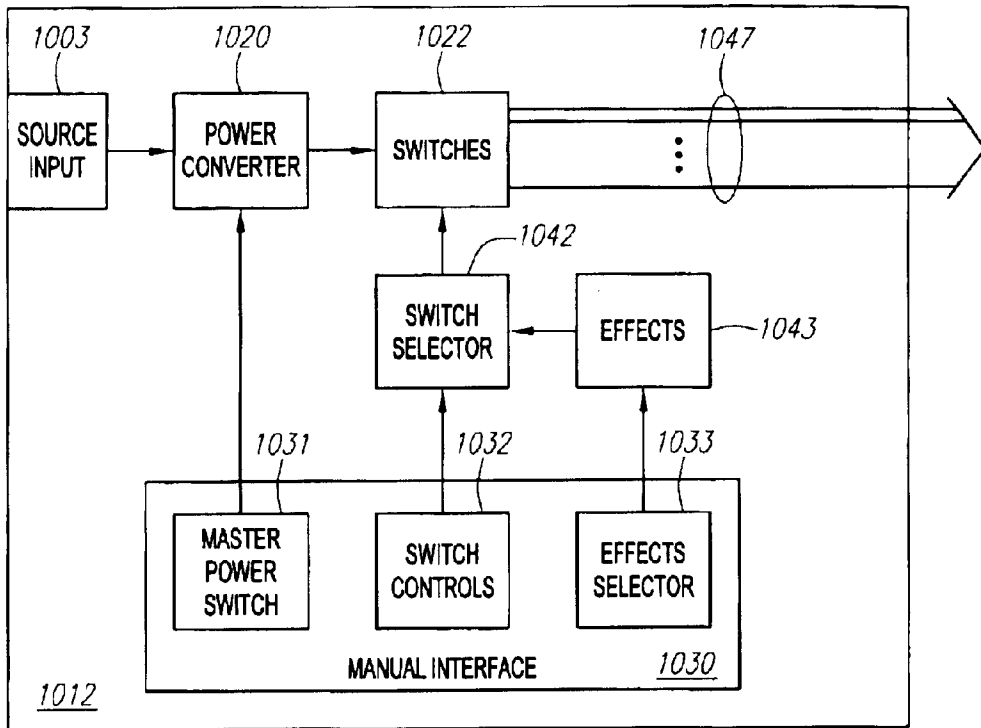

FIG. 10A

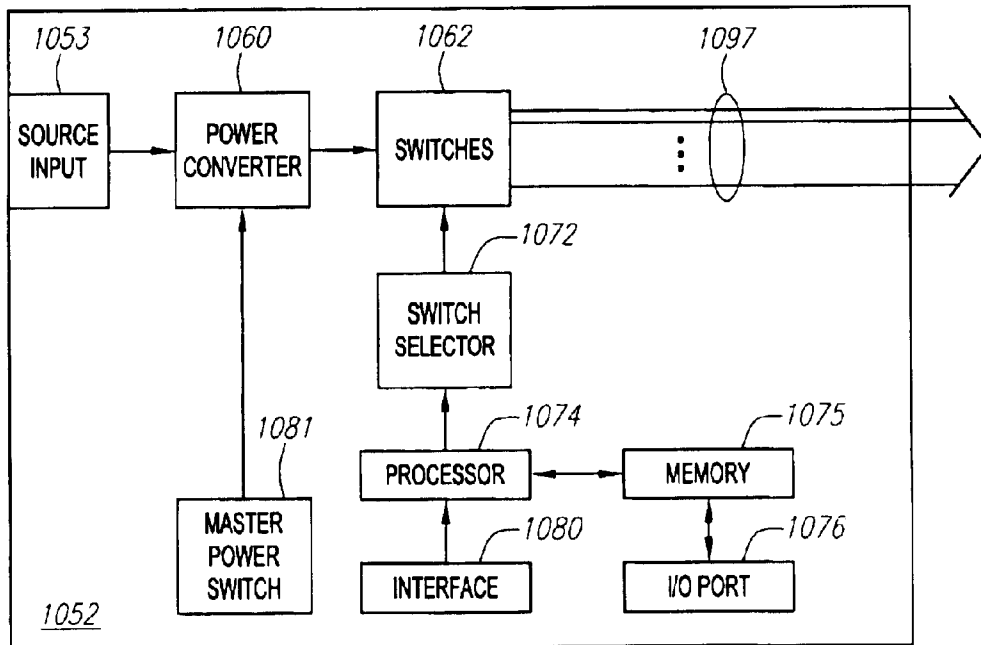

FIG. 10B

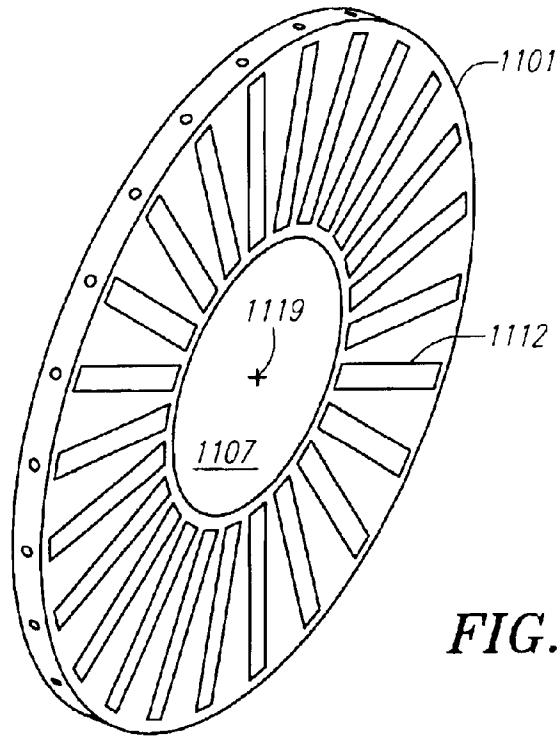

FIG. 11

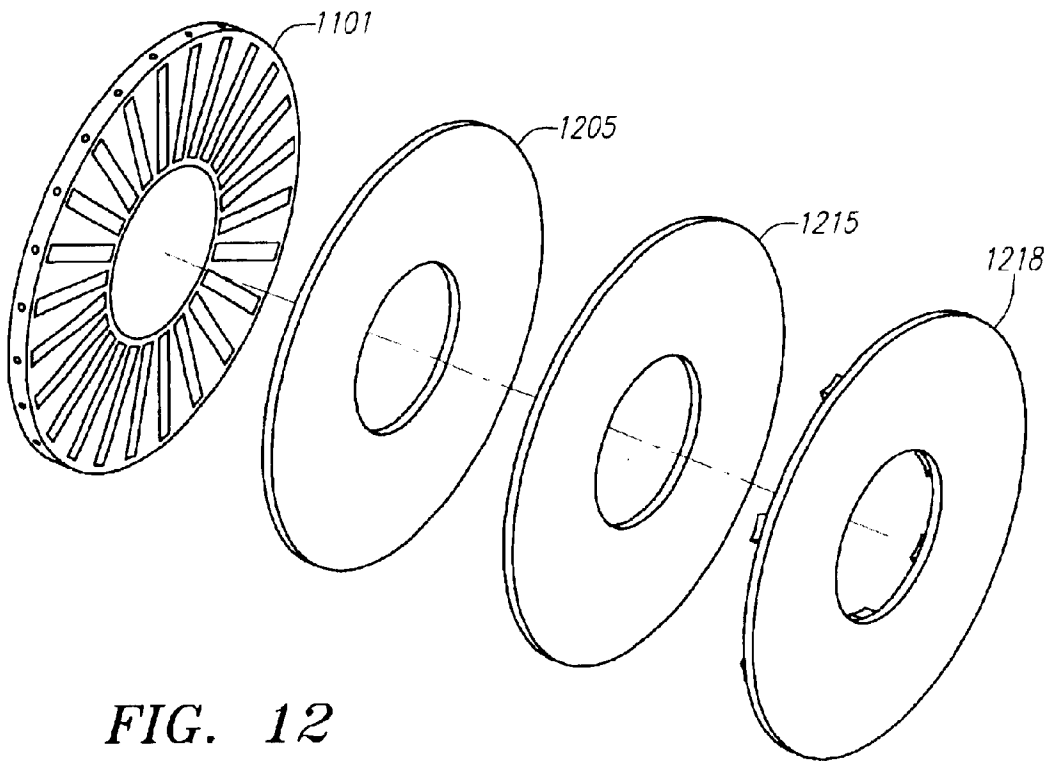

FIG. 12

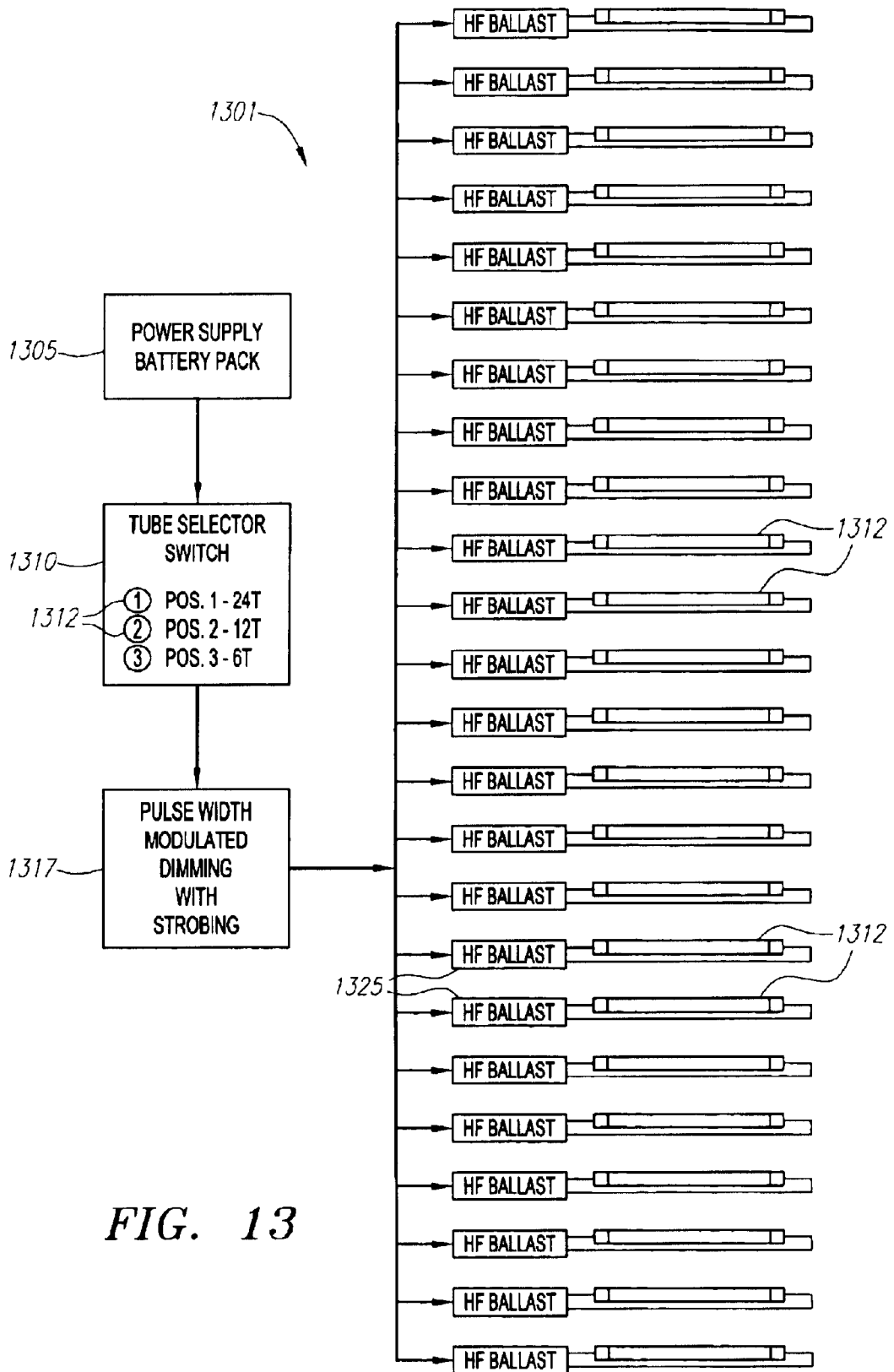

FIG. 13

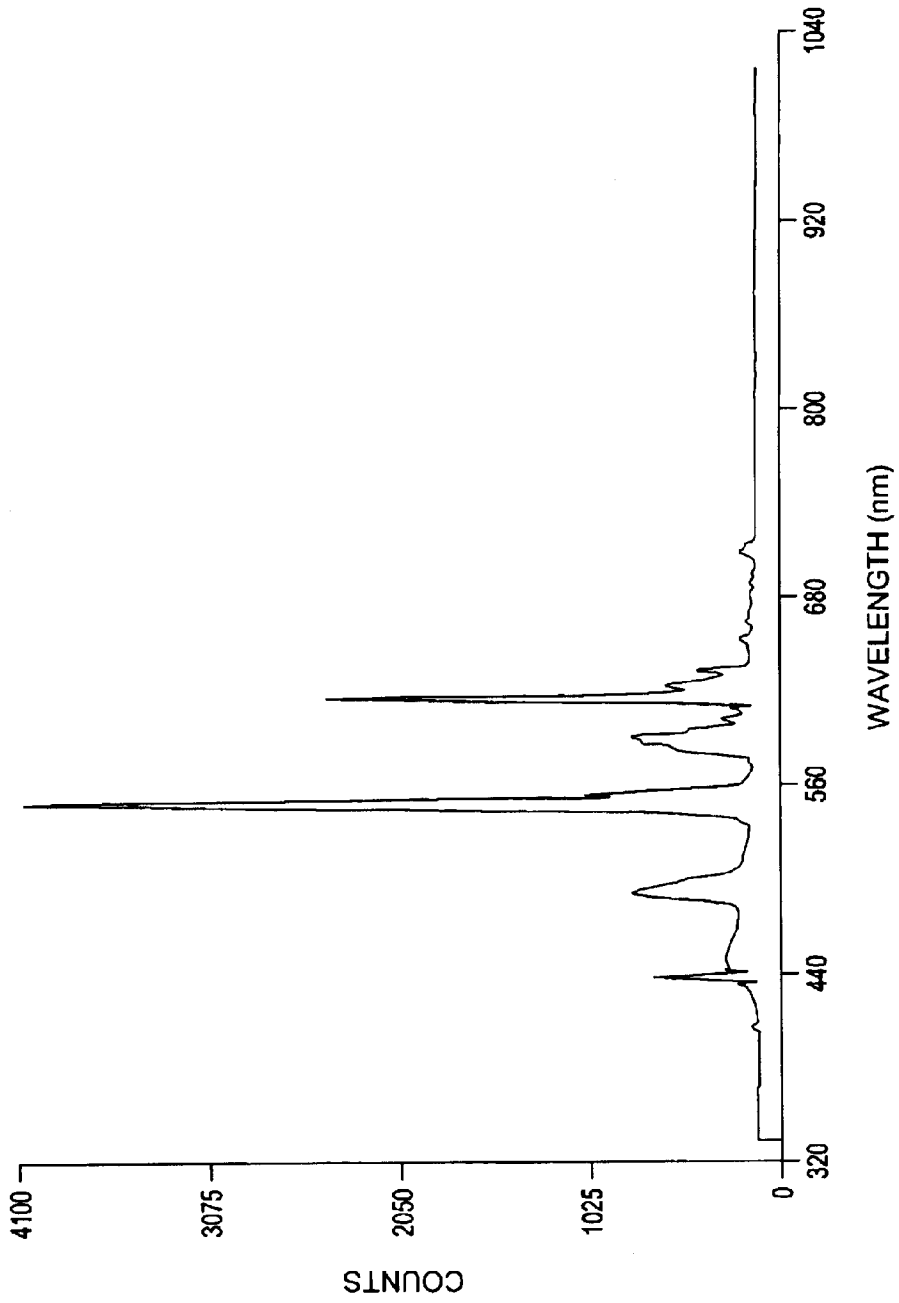

FIG. 14

FIG. 15A

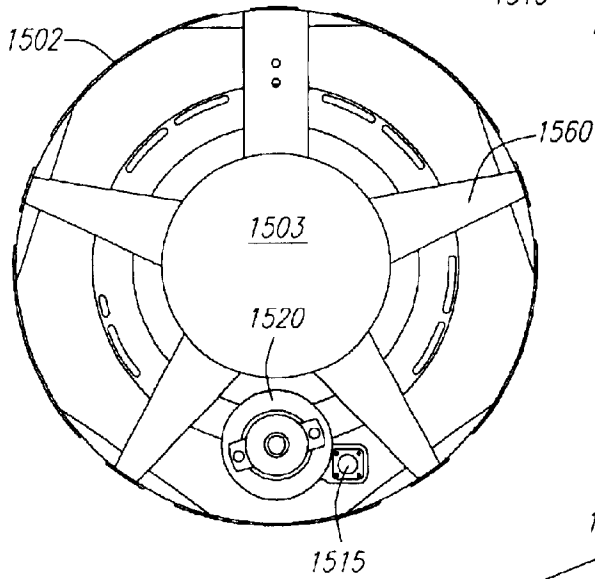
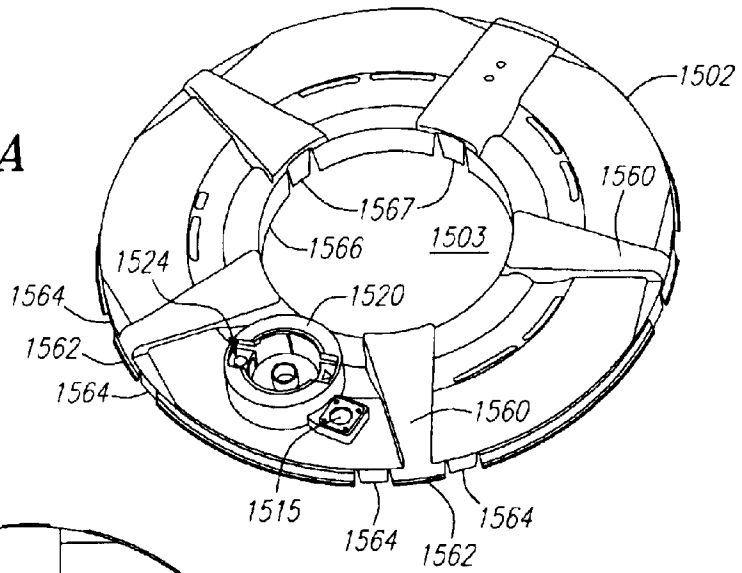
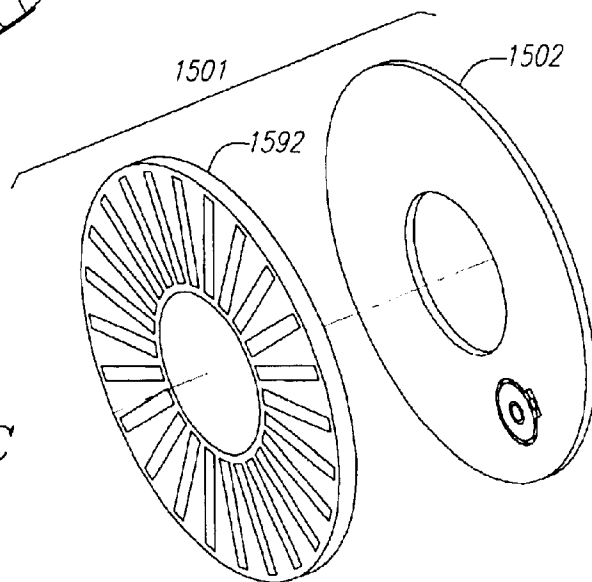

FIG. 15B

FIG. 15C



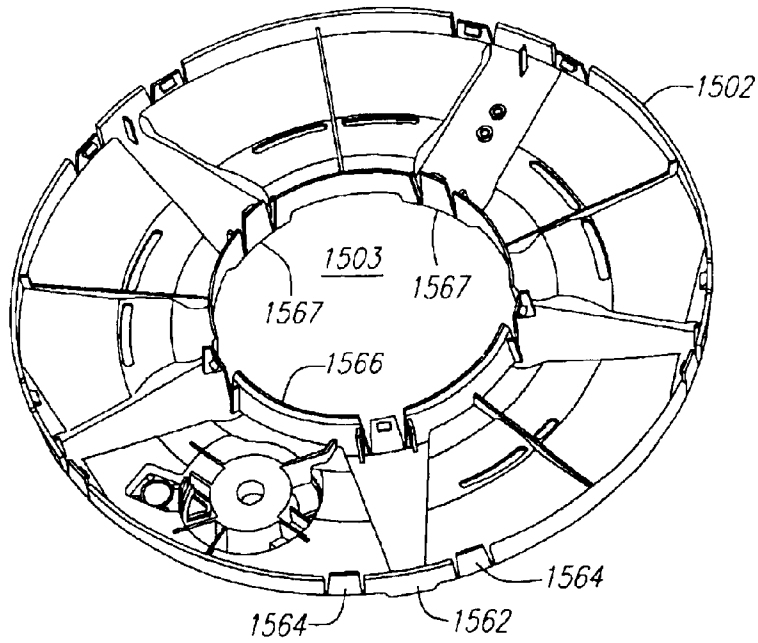

FIG. 16A

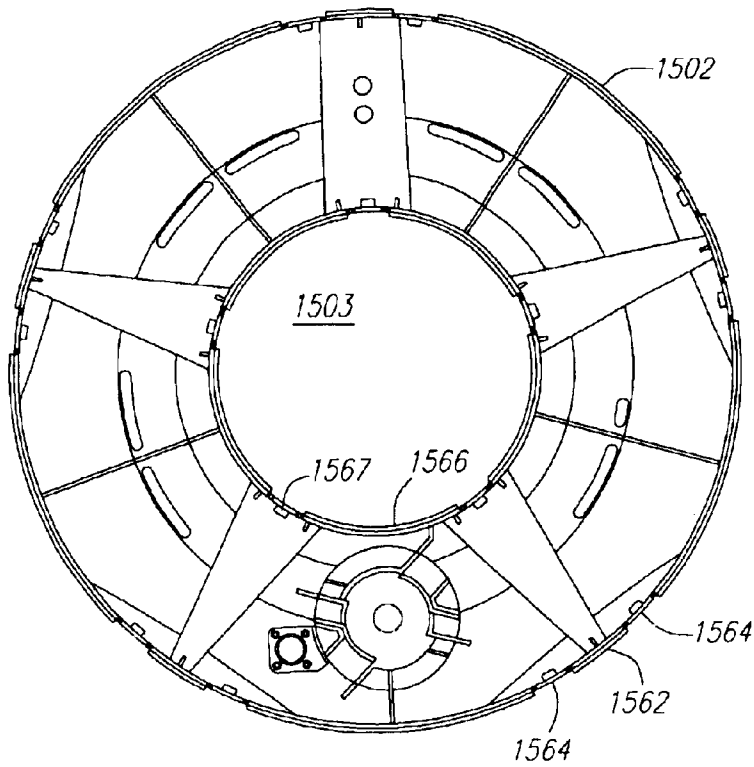
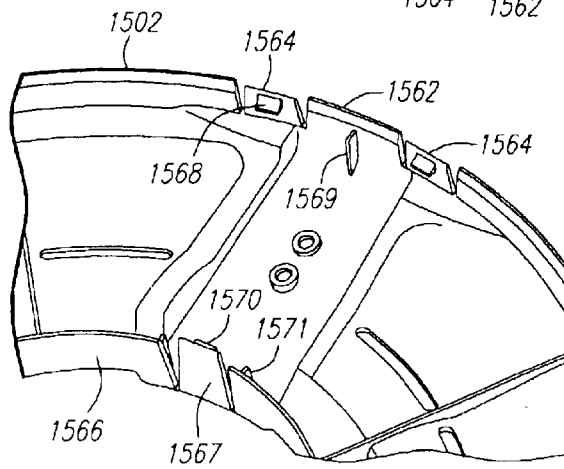
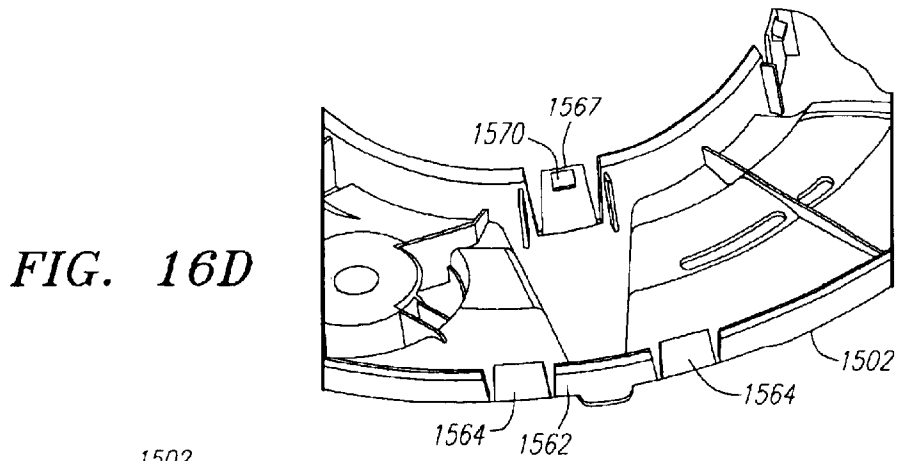
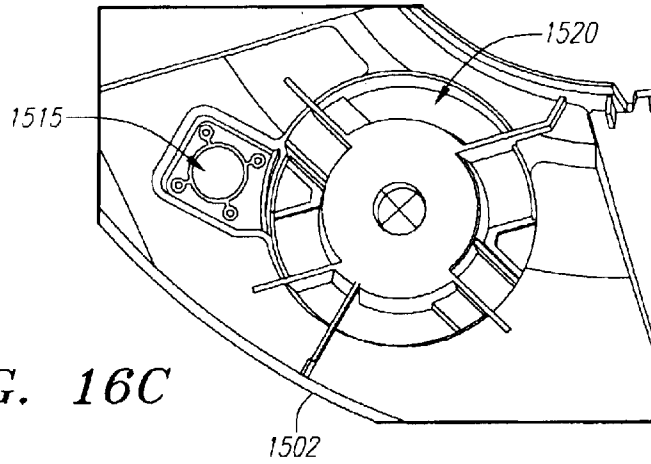

FIG. 16B



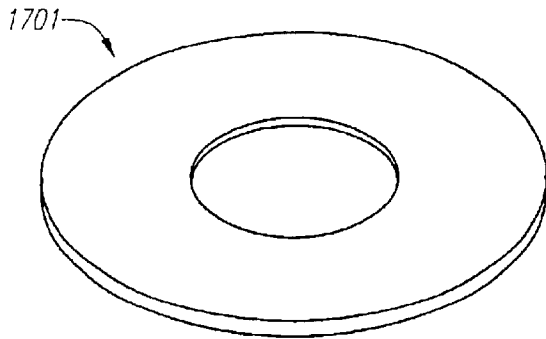

FIG. 17

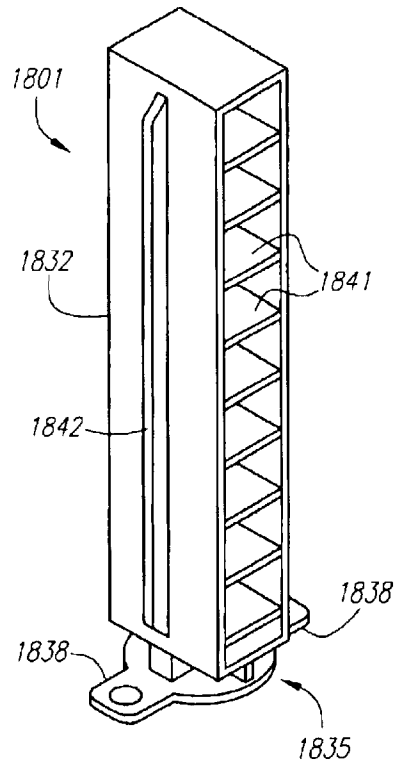

FIG. 18

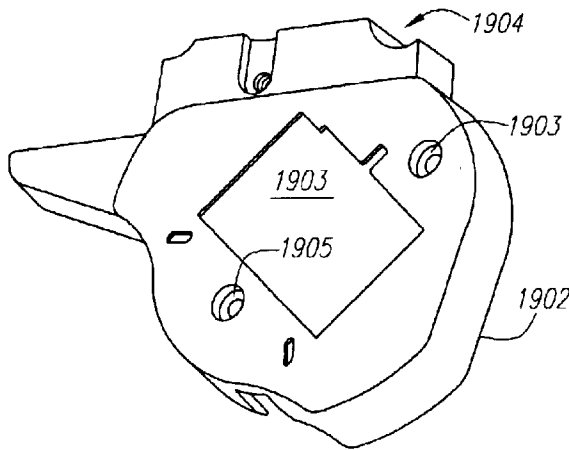

FIG. 19A

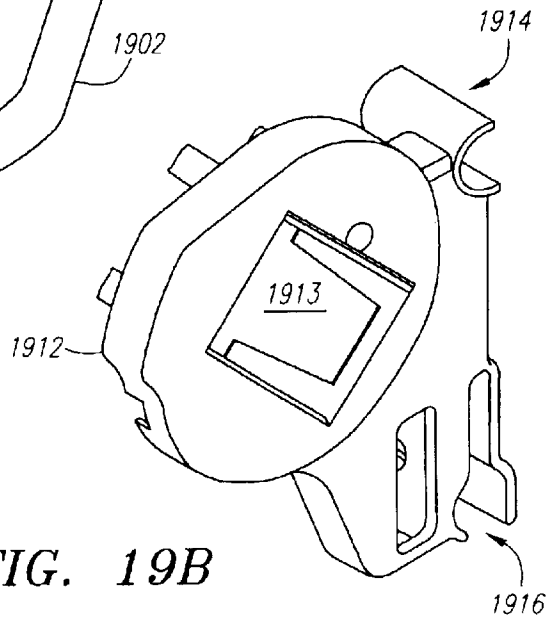

FIG. 19B

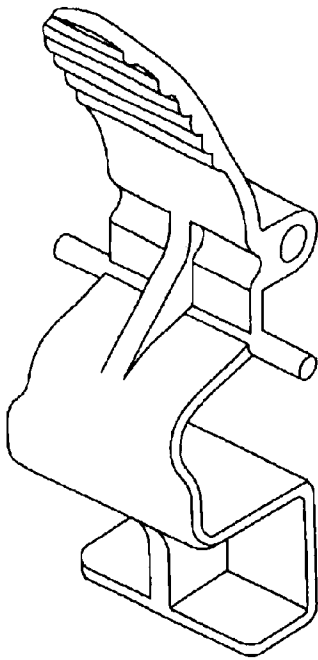

FIG. 20

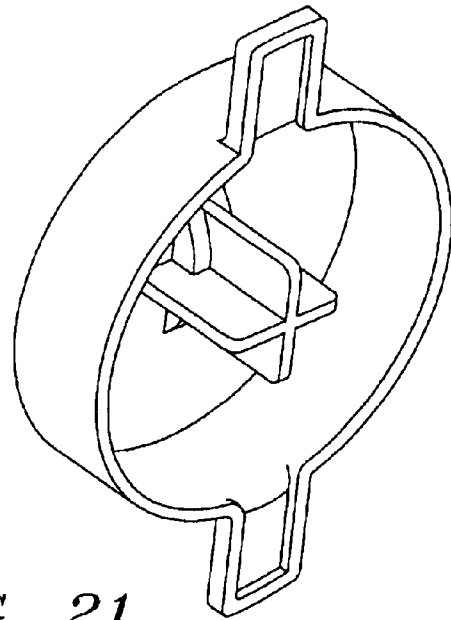

FIG. 21

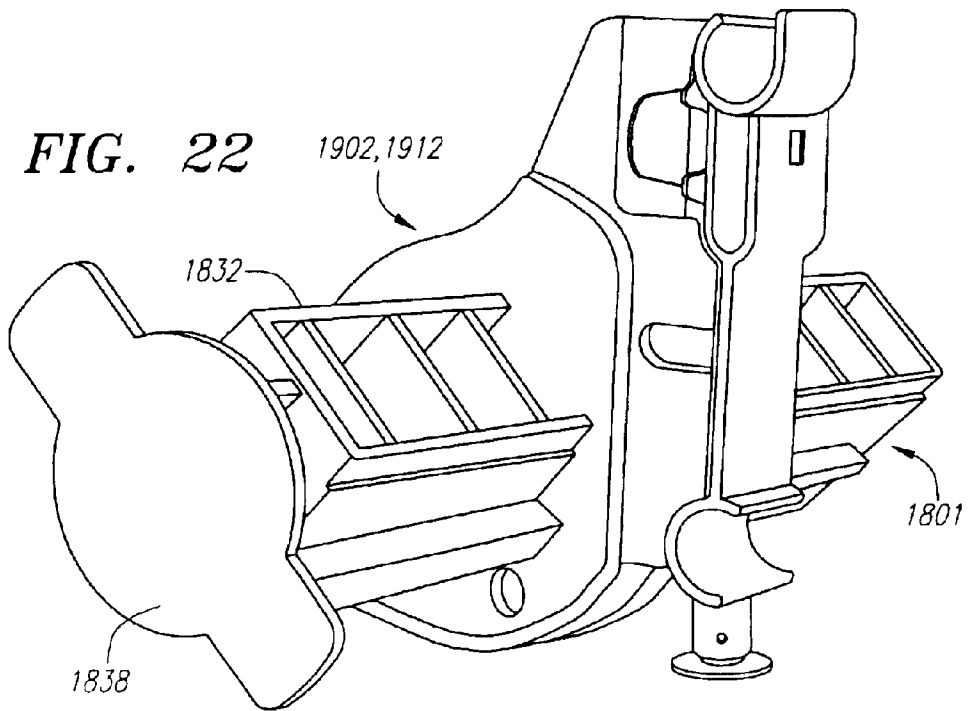
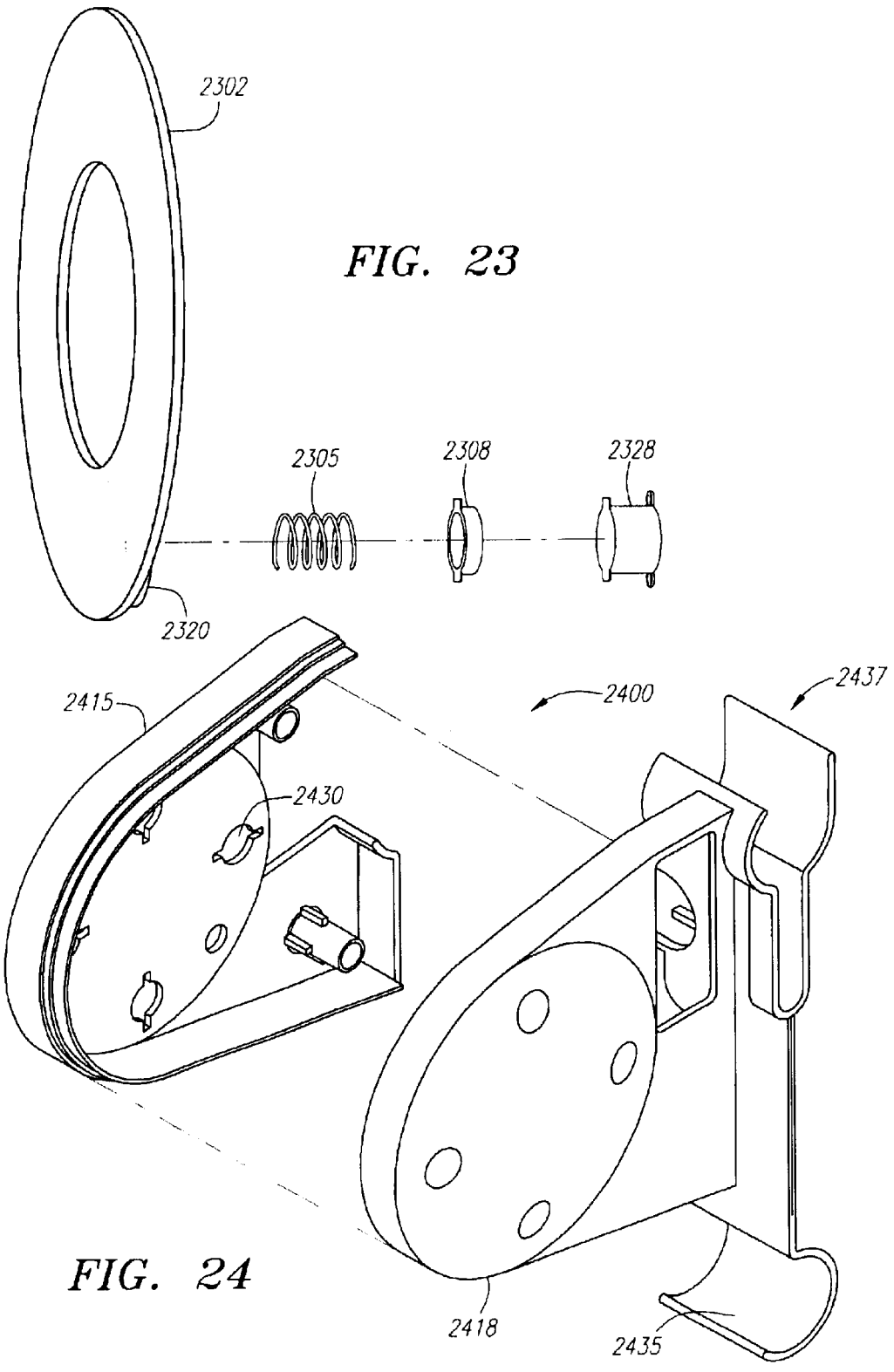

FIG. 22



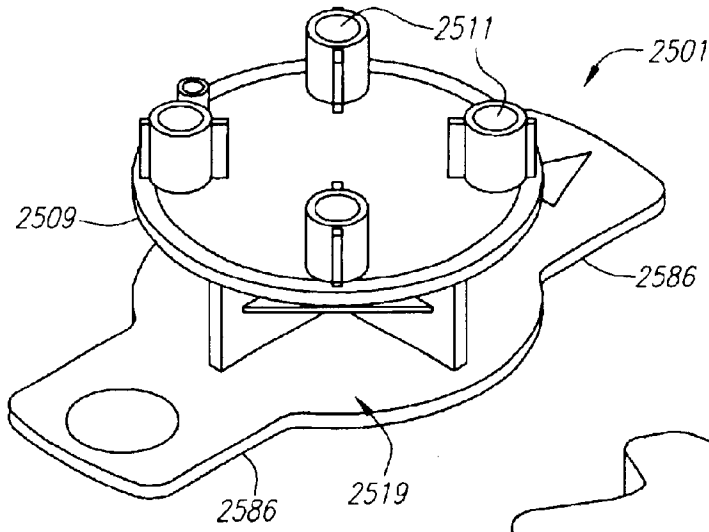

FIG. 25

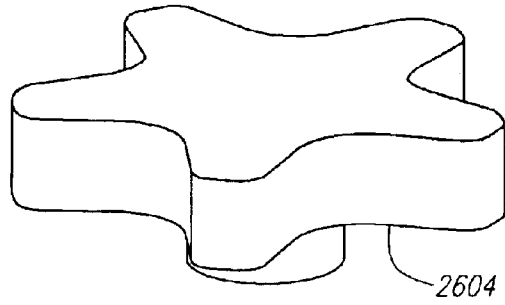

FIG. 26

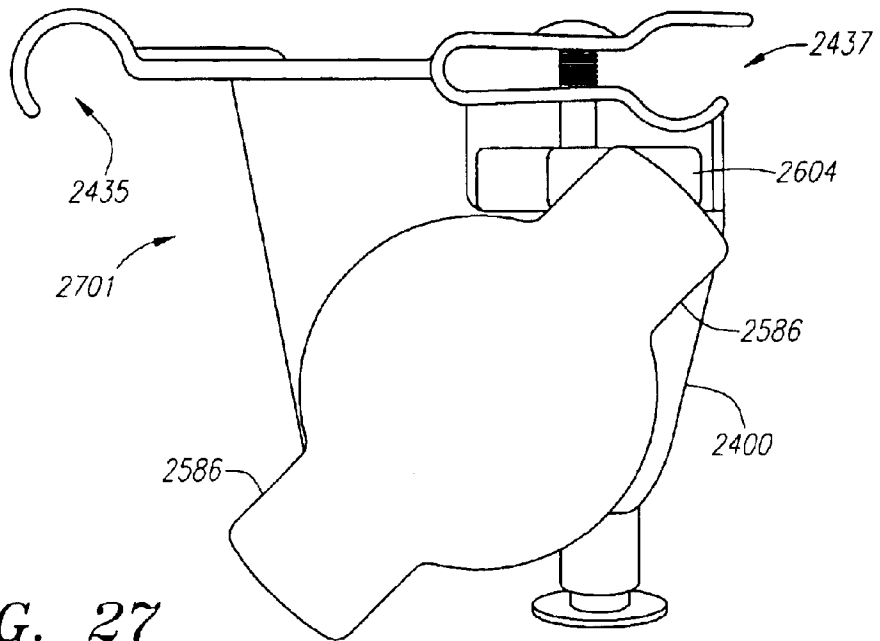

FIG. 27

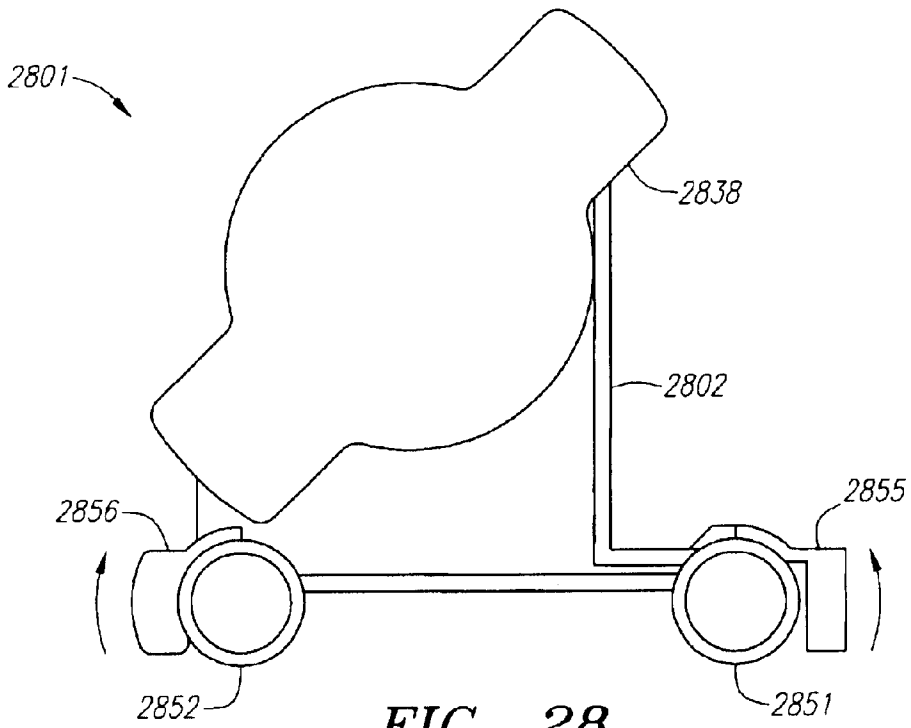

FIG. 28

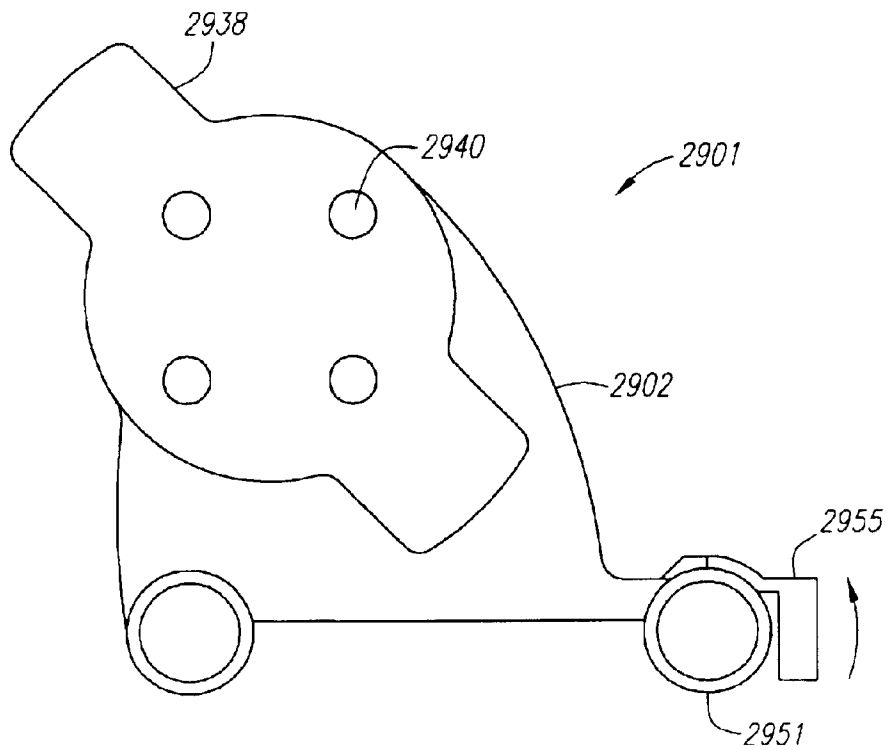

FIG. 29

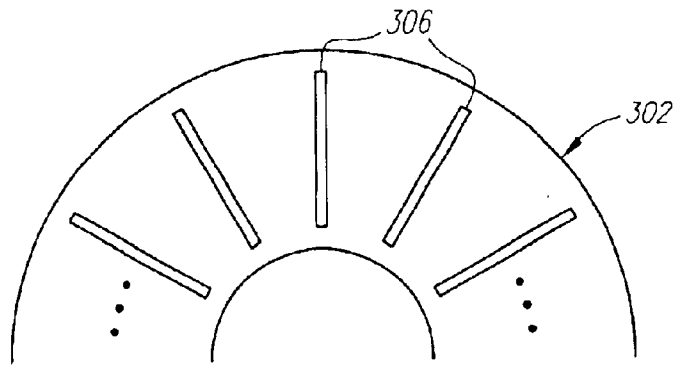

FIG. 30A

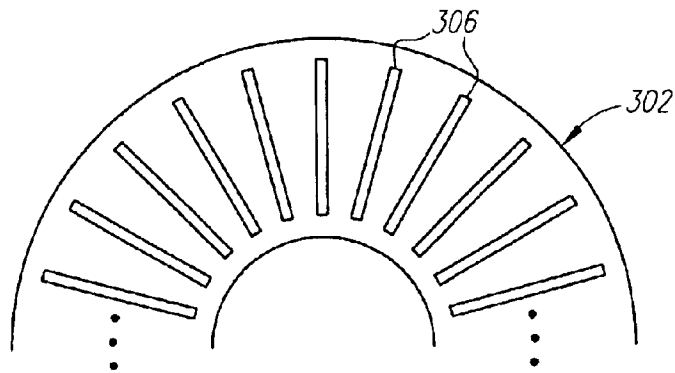

FIG. 30B

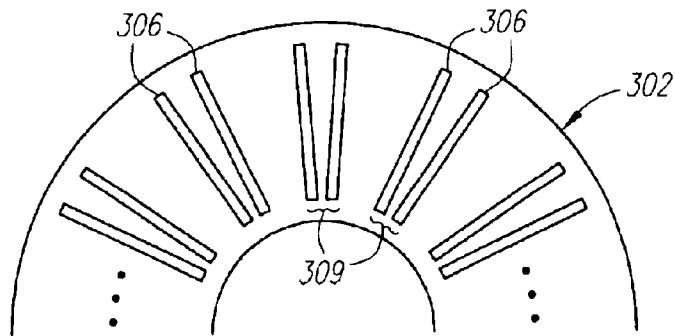

FIG. 30C

## WIDE AREA LIGHTING EFFECTS SYSTEM

## BACKGROUND OF THE INVENTION

## 1) Field of the Invention

The field of the present invention relates to lighting systems as may be used in film, television, close-up photography, and other applications.

## 2) Background

Lighting systems are an essential part of the film and photography industries. Proper illumination is necessary when filming movies, television shows, or commercials, shooting video clips, or taking still photographs, whether such activities are carried out indoors or outdoors. A desired illumination effect may also be desired for live performances on stage or in any other type of setting.

The general purpose of a lighting system is to illuminate a subject to achieve a desired effect. Often it is desirable to obtain even lighting that minimizes shadows. It may be necessary or desired to obtain lighting that has a certain tone, warmth or intensity. It may also be necessary or desired to have certain lighting effects, such as colorized lighting, strobed lighting, gradually brightening or dimming illumination, or different intensity illumination in different fields of view.

Various conventional techniques for lighting in the film and television industries, and various illustrations of lighting equipment, are described, for example, in *Lighting for Television and Film* by Gerald Millerson (3<sup>rd</sup> ed. 1991), at pages 96–131 and 295–349, and in *Professional Lighting Handbook* by Verne Carlson (2<sup>nd</sup> ed. 1991), at pages 15–40.

As one example illustrating a need for an improved lighting effects system, it can be quite challenging to provide proper illumination for the lighting of faces in television and film, especially for situations where close-ups are required. Often, certain parts of the face must be seen clearly. The eyes, in particular, can provide a challenge for proper lighting. Light reflected in the eyes is known as “eye lights” or “catch lights.” Without enough reflected light, the eyes may seem dull. A substantial amount of effort has been expended in constructing lighting systems that have the proper directivity, intensity, tone and other characteristics to result in aesthetically pleasing “eye lights” while also meeting other lighting requirements, and without adversely impacting lighting of other features.

Because of the varied settings in which lighting systems are used, the conventional practice in the film, commercial and related industries is for a lighting system, when needed, to be custom designed for each shoot. This practice allows the director or photographer to have available a lighting system that is of the necessary size, and that provides the desired intensity, warmth, tone and effects. Designing and building customized lighting systems is often an expensive and time-consuming process.

The most common lighting systems in film, commercial and photographic settings use either incandescent or fluorescent light elements. However, conventional lighting systems have drawbacks or limitations which can limit their flexibility or effectiveness. For example, incandescent lights have been employed in lighting systems in which they have been arranged in various configurations, including on ring-shaped mounting frames. However, the mounting frames used in incandescent lighting systems are often large and ponderous, making them difficult to move around and otherwise work with. A major drawback of incandescent light-

ing systems is the amount of heat generating by the incandescent bulbs. Because of the heat intensity, subjects cannot be approached too closely without causing discomfort to the subject and possibly affecting the subject’s make-up or appearance. Also, the heat from the incandescent bulbs can heat the air in the proximity of the camera, cause a “waver-  
ing” effect to appear on the film or captured image. Incandescent lighting may cause undesired side effects when filming, particularly where the intensity level is adjusted. As the intensity level of incandescent lights change, their hue changes as well. Film is especially sensitive to these changes in hue, significantly more so than the human eye.

In addition to these problems or drawbacks, incandescent lighting systems typically draw quite a bit of power, especially for larger lighting systems which may be needed to provide significant wide area illumination. Incandescent lighting systems also generally require a wall outlet or similar standard source of alternating current (AC) power.

Fluorescent lighting systems generate much less heat than incandescent lighting systems, but nevertheless have their own drawbacks or limitations. For example, fluorescent lighting systems, like incandescent lighting systems, are often large and cumbersome. Fluorescent bulbs are generally tube-shaped, which can limit the lighting configuration or mounting options. Circular fluorescent bulbs are also commercially available, and have been used in the past for motion picture lighting.

A major drawback with fluorescent lighting systems is that the low lighting levels can be difficult or impossible to achieve due to the nature of fluorescent lights. When fluorescent lights are dimmed, they eventually begin to flicker or go out as the supplied energy reaches the excitation threshold of the gases in the fluorescent tubes. Consequently, fluorescent lights cannot be dimmed beyond a certain level, greatly limiting their flexibility. In addition, fluorescent lights suffer from the same problem as incandescent lights when their intensity level is changed; that is, they tend to change in hue as the intensity changes, and film is very sensitive to alterations in lighting hue.

Typically, incandescent or fluorescent lighting systems are designed to be placed off to the side of the camera, or above or below the camera. Because of such positioning, lighting systems may provide uneven or off-center lighting, which can be undesirable in many circumstances.

Because of their custom nature, both incandescent lighting systems and fluorescent lighting systems can be difficult to adapt to different or changing needs of a particular film project or shoot. For example, if the director or photographer decides that a different lighting configuration should be used, or wants to experiment with different types of lighting, it can be difficult, time-consuming and inconvenient to re-work or modify the customized lighting setups to provide the desired effects. Furthermore, both incandescent lighting systems and fluorescent lighting systems are generally designed for placement off to the side of the camera, which can result in shadowing or uneven lighting.

A variety of lighting apparatus have been proposed for the purpose of inspecting objects in connection with various applications, but these lighting apparatus are generally not suitable for the movie, film or photographic industries. For example, U.S. Pat. No. 5,690,417 describes a surface illuminator for directing illumination on an object (i.e., a single focal point). The surface illuminator has a large number of light-emitting diodes (LEDs) arranged in concentric circles on a lamp-supporting housing having a circular bore through which a microscope or other similar instrument can be

positioned. The light from the LEDs is directed to a single focal point by either of two methods. According to one technique disclosed in the patent, a collimating lens is used to angle the light from each ring of LEDs towards the single focal point. According to another technique disclosed in the

Other examples of lighting apparatus used for the purpose of inspecting objects are shown in U.S. Pat. Nos. 4,893,223 and 5,038,258. In both of these patents, LEDs are placed on the interior of a spherical surface, so that their optical axes intersect at a desired focal point.

Lighting apparatus specially adapted for illumination of objects to be inspected are generally not suitable for the special needs of the film, commercial or photographic industries, or with live stage performances, because the lighting needs in these fields differs substantially from what is offered by object inspection lighting apparatus. For example, movies and commercials often require illumination of a much larger area than what object inspection lighting systems typically provide, and even still photography often requires that a relatively large subject be illuminated.

It would therefore be advantageous to provide a lighting apparatus or lighting effects system well suited for use in the film, commercial and photographic industries, and with live stage performances, that overcomes one or more of the foregoing disadvantages, drawbacks or limitations.

#### SUMMARY OF THE INVENTION

The invention is generally directed in one aspect to a novel lighting effects system and method as may be used, for example, in film and photography applications.

In one embodiment, a lighting effects system comprises an arrangement of low power lights mounted on a frame having an opening through which a camera can protrude. The low power lights may be embodied as light-emitting diodes (LEDs) or light emitting crystals (LECs), for example, arranged on the frame in a pattern of concentric circles or other uniform or non-uniform pattern. The frame preferably has a circular opening through which a camera can protrude, and one or more mounting brackets for attaching the frame to a camera. The low power lights may be electronically controllable so as to provide differing intensity levels, either collectively, individually, or in designated groups, and, in some embodiments, may be controlled through preprogrammed patterns.

Further embodiments, variations and enhancements are also disclosed herein.

#### BRIEF DESCRIPTION OF THE DRAWINGS

FIG. 1 is a diagram of an example of a lighting effects system in accordance with one embodiment as disclosed herein, illustrating placement of a camera relative to a lighting frame.

FIG. 2 is a block diagram of a lighting effects system showing various components of a preferred system.

FIG. 3 is an oblique view diagram illustrating an example of attachment of one type of camera mounting assembly to a particular type of lighting assembly frame.

FIG. 4 is a front view diagram of a lighting assembly frame with small, low-power lamps to provide illumination arranged in a preferred pattern.

FIG. 5 is a diagram illustrating aspects of the lighting effect provided by a lighting assembly such as, for example, shown in FIG. 4.

FIG. 6 is a diagram illustrating various human eye features that may be of interest in providing illumination for films, commercials or photography.

FIG. 7 is a diagram of a light segment as may be used, for example, with the lighting assembly of FIG. 4, along with filtering lens(es).

FIG. 8 is a diagram illustrating the effect of a filtering lens on an individual light element.

FIG. 9 is a graph illustrating a frequency distribution of light in accordance with one lighting effects system embodiment as disclosed herein.

FIGS. 10A and 10B are a block diagrams of two different types of electronic controllers as may be employed, for example, in the lighting effects system illustrated in FIG. 2.

FIG. 11 is an oblique view diagram of another embodiment of a lighting assembly frame as disclosed herein.

FIG. 12 is a diagram illustrating various options and accessories as may be used in connection with the lighting assembly frame depicted in FIG. 11.

FIG. 13 is a diagram of electronic control circuitry as may be employed, for example, with the lighting effects system illustrated in FIG. 11.

FIG. 14 is a graph illustrating a frequency distribution of light in accordance with another lighting effects system embodiment as disclosed herein.

FIGS. 15A and 15B are diagrams showing an oblique view and a top view, respectively, of a portion of a lighting assembly frame.

FIG. 15C is a diagram illustrating assembly of a lighting assembly frame from two halves thereof.

FIGS. 16A and 16B are diagrams showing an oblique view and a top view, respectively, of the backside of the lighting assembly frame portion illustrated in FIGS. 15A and 15B, while FIGS. 16C, 16D and 16E are diagrams showing details of the lighting assembly frame portion shown in FIGS. 16A and 16B.

FIG. 17 is a diagram of a cover as may be used in connection with the lighting effects system of FIG. 2 or the frame assembly of FIG. 4.

FIG. 18 is a diagram of a portion of a preferred camera mounting assembly.

FIGS. 19A and 19B are diagrams collectively illustrating another portion of a preferred camera mounting assembly.

FIG. 20 is a diagram of a retention clip for a camera mounting assembly.

FIG. 21 is a diagram of a plunger used in connection with attaching a mounting assembly to a lighting frame, in accordance with one technique as disclosed herein.

FIG. 22 is a diagram of a mounting assembly with components from FIGS. 18 and 19 shown assembled.

FIG. 23 is a diagram illustrating one technique for attaching a camera mounting assembly to a lighting frame.

FIGS. 24, 25 and 26 are diagram of components relating to another type of camera mounting assembly.

FIG. 27 is a diagram showing components of FIGS. 24, 25 and 26 assembled together.

FIGS. 28 and 29 are diagrams of alternative embodiments of integral or semi-integral camera mounting assemblies.

FIGS. 30A, 30B and 30C are diagrams illustrating various alternative lamp patterns.

#### DETAILED DESCRIPTION OF PREFERRED EMBODIMENTS

FIG. 1 is a diagram of an example of a preferred lighting effects system 100 in accordance with one embodiment as

disclosed herein, illustrating placement of a camera **140** relative to a lighting frame **102**. The lighting frame **102** shown in FIG. **1** may be generally ring-shaped (as shown in, for example, FIGS. **3** and **4**, and later described herein), and may define a central hole **103** through which the camera **140** can view. The camera **140** itself, while illustrated in FIG. **1** as a motion picture type camera, may be embodied as any type of image capture or optical viewing device, whether analog or digital in nature. For example, the camera **140** may use film or solid state image capture circuitry (e.g., CCDs), and may be a still photography camera or a motion picture camera. In a preferred embodiment, the lighting frame **102** is physically attached to the camera **140** using a camera mounting, as further described herein.

FIG. **2** is a block diagram of a lighting effects system **200** that may, if desired, be constructed in accordance with various principles illustrated in or described with respect to FIG. **1**. As illustrated in FIG. **2**, the lighting effects system **200** comprises a lighting frame **202** upon which are mounted or otherwise affixed a plurality of lamps **205**. Preferred arrangements of the lamps **205** are described further herein. The lighting frame **202** may include a mounting assembly receptor **220** for receiving a mounting assembly **230** (preferably removable in nature), and an electrical socket **215** for receiving a cable **213** providing electrical power to the lamps **205** from a power source **210**, although in alternative embodiments battery power may be used. A power controller **212** is preferably interposed between the power source **210** and the electrical socket **215**, for providing various lighting effect functions described in more detail hereinafter, such as, for example, dimming, strobing, selective activation, pulsation, and so on, or combinations thereof.

In a preferred embodiment, the lighting frame **202** is ring-shaped, and the lamps **205** are arranged in a pattern around the center hole of the lighting frame **202** so as to provide the desired lighting condition—typically, the lamps **205** will be arranged in a symmetrical, regular pattern so as to provide relatively even lighting over the area of interest. The lighting frame **202** is preferably comprised of a lightweight, durable material, such as thermoplastic and/or aluminum, with a flat black finish (either paint, coating or material) so as to eliminate any reflections from the front of the lighting frame **202** that might cause ghosts to the final image.

An example of a preferred lighting frame **302** is depicted from various angles in FIGS. **3** and **4**. FIG. **4** shows a front view of a lighting frame **302**, illustrating the preferred ring-shaped nature thereof. In the embodiment shown in FIG. **4**, a number of lamp segments **306** are arranged in a radial or arrayed pattern around the center hole **303** of the lighting frame **302**. The lamp segments **306** are positioned along rays **308** emanating from a center point **307** of the lighting frame **302**, and are preferably equidistant from one another (i.e., the rays **308** are preferably defined such that all of the angles between neighboring rays **308** are equal). The equidistant placement of the lamp segments **306** results in a symmetrical, even pattern that advantageously provides even lighting over an area of interest.

The density of the lamp pattern may vary, and is dictated in part by the particular lighting needs. Examples of alternative lamp arrangement patterns are shown in FIGS. **30A–30C**. FIGS. **30A** and **30B** show the lighting frame **302** with different pattern densities of lamp segments **306**. FIG. **30C** illustrates a lamp pattern in which pairs **309** of lamp segments **306** are arranged near adjacent to one another, while each pair **309** of lamp segments **306** is positioned

further away from its neighboring pair **309** than from the other lamp segment **306** that is part of the lamp segment pair **309**. The lamp patterns shown in FIGS. **30A**, **30B** and **30C** are meant to be merely illustrative and not exhaustive. Other lamp patterns might involve, for example, triplets of lamp segments (rather than pairs or singles), or alternating single lamps with pairs and/or triplets, or lamp segments which have gradually increasing or decreasing spacing between them, or lamp segment clusters having the same or different numbers of lamp segments in each cluster, to name a few. The lamp pattern can thus be varied to suit the particular lighting needs, but is preferably symmetric at least in those situations calling for even lighting over the area of interest.

Each of the lamp segments **306** preferably comprises a plurality of low power lamps **305**, such as illustrated, for example, in FIG. **4**. The low power lamps are preferably solid state in nature and may comprise, for example, light-emitting diodes (LEDs), light-emitting crystals (LECs), or other low power, versatile light sources. The number of low power lamps **305** in each lamp segment **306** may be the same or may vary among lamp segments **306**. If the number of low power lamps **305** is the same in each lamp segment **306** and are spaced the same (for example, equidistant from one another) within each lamp segment **306**, then the resulting pattern will be a plurality of concentric circles of low power lamps **305** radiating outward from the inner circular portion to the outer circular portion of the lighting frame **302**. It will be appreciated, however, that the low power lamps **305** need not be arranged in segments **306** as illustrated in FIG. **4**, but may be arranged in clusters or other patterns, whether uniform or non-uniform, over the lighting frame **302**. However, a symmetrical, regular pattern of low power lamps **305** is preferred, at least where uniform lighting is desired over an area of interest.

FIG. **5** illustrates the effect of a lighting frame assembly such as light frame **302** with low power lamps **305** arranged as shown in FIG. **4**, in illuminating a subject **646**. As shown in FIG. **5**, radiating light regions **620**, **621** from lamps arranged on the front surface of the lighting frame **302** (as illustrated in FIG. **4**, for example) overlap one another in a manner so as to provide lighting from multiple angles. With a radial or arrayed pattern of lamp segments **306** as shown in FIG. **4**, a subject **646** may be relatively evenly illuminated from every angle. FIG. **1** illustrates a preferred placement of a camera **140** (including any type of image capture device, whether film based, solid state/CCD, or otherwise) with respect to a lighting frame **102** (which may be embodied, for example, as lighting frame **302**). As illustrated in FIG. **1**, the camera **140** may be positioned so that its lens or optical front-end peers through the central hole **103** of the lighting frame **102**, thus allowing the lighting to be presented from the same angle and direction as the camera viewpoint.

FIG. **6** illustrates how the lighting frame assembly with the pattern of lamp segments **306** as shown in FIG. **4** may advantageously illuminate a human subject's eyes. In FIG. **6**, the iris **650** of the subject's eye **654** is illustrated showing a circular pattern of reflected light segments **652** around the iris **650**. A lighting pattern of a lighting system such as illustrated in FIG. **4** can illuminate the iris **650** of the subject's eye **654** from multiple angles, thus helping provide desirable "eye lights" or "catch lights" with respect to a human subject **546**, as well as providing uniform, even lighting over the area of interest.

Turning now to FIG. **3**, an oblique view of the lighting frame **302** is shown illustrating an example of attachment of one type of camera mounting assembly **330** to the lighting frame **302**. In the particular embodiment illustrated in FIG.

3, a mounting assembly receptor 320 is affixed to, molded as part of, or otherwise attached to the lighting frame 302. The camera mounting assembly 330 is preferably configured so as to attach securely to the mounting assembly receptor 320. The mounting assembly receptor 320 may, for example, include a socket 323 or similar indentation adapted to receive a corresponding member 335 on the camera mounting assembly 330. The member 335 may be attached to an elongated rod or arm 332, along which a camera clamp 334 may be slidably engaged. The camera clamp 334 preferably includes a generally U-shaped clamping portion 336 which may be securely attached along the housing of a camera, and may advantageously be moved along the elongated rod or arm 332 and clamped into a suitable position using a clamping screw or other fastening mechanism.

FIGS. 15A and 15B are diagrams showing an oblique view and a frontal view, respectively, of one portion of a lighting assembly frame 1502 in accordance with one or more of the concepts or principles explained with respect to the embodiment shown in FIG. 3. As illustrated in FIGS. 15A and 15B, the lighting assembly frame portion 1502 is generally ring-shaped in nature, having a central hole 1503 for allowing a camera or other image capture device to view through the lighting assembly frame. The lighting assembly frame portion 1502 may be reinforced, if desired, with ribs 1560, and may include, as noted with respect to FIG. 3, a mounting assembly receptor 1520 for receiving a camera mounting assembly (not shown in FIG. 15A), and an electrical socket 1515 for receiving a cable or wires for providing power to the lamps of the lighting assembly.

The lighting frame portion 1502 illustrated in FIG. 15A comprises one half (specifically, the backside half) of a complete lighting frame assembly. A corresponding lighting frame portion 1592, as shown in FIG. 15C, may be adapted to fit securely to the lighting frame portion 1502, and may attach thereto by, for example, exterior locking tabs 1564 and/or interior locking tabs 1567, which are shown in FIGS. 15A and 15B. Alternatively, other means for fastening together the lighting frame assembly 1501 may be used, such as screws, glue, etc.

Likewise, the mounting assembly receptor 1520 may comprise any suitable mechanism for securing a camera mounting assembly to the lighting frame portion 1502 of the lighting frame assembly 1501. In the example illustrated in FIGS. 15A and 15B, the mounting assembly receptor 1520 may comprise a raised, slightly tapered cylindrical housing, defining a hollow cylindrical chamber in which the camera mounting assembly may be fitted. If the lighting frame portion 1502 is formed of plastic, for example, then the mounting assembly receptor 1520 may be formed through an injection molding process. FIG. 18 depicts an example of a portion of a camera mounting assembly 1801 as may be affixed to the lighting frame portion 1502 using the mounting assembly receptor 1520. The camera mounting assembly 1801 in FIG. 18 comprises an elongated rod or arm 1832, at the end of which is affixed an attachment member 1835 having a generally circular body portion with two wing-like protruding tabs 1838. The tabs 1838 may be fitted into two corresponding indentations 1524 in the ring-shaped top surface of the cylindrical housing of the mounting assembly receptor 1520. The camera mounting assembly 1801 may then be twisted in a clockwise direction to cause the tabs 1838 to slide through the slits adjacent to the indentations 1524 in the mounting assembly receptor 1520, allowing the camera mounting assembly 1801 to be slid downward, then twisted in a counter-clockwise direction and locked into place in the mounting assembly receptor 1520. The camera

mounting assembly 1801 may be disengaged from the lighting frame portion 1501 by manually applying pressure to release the locking tabs and twisting the camera mounting assembly 1801 in the opposite (i.e., clockwise in this example) direction from that originally used to bring it into a locking position. The camera mounting assembly 1801 may then be raised upwards and twisted in a counter-clockwise direction to cause the tabs 1838 to slide back through the slits adjacent to the indentations 1524 in the mounting assembly receptor 1520, thereby completely releasing the camera mounting assembly 1801.

A variety of other means may alternatively be used to affix a camera mounting assembly to the lighting frame portion 1502, but the mechanism used in the embodiment depicted in FIGS. 15A and 15B has the advantage of not requiring additional pieces (such as screws), and being relatively simple and quick to use.

A main purpose of the camera mounting assembly 1801 is to allow the lighting frame assembly to be secured to a camera or other image capture device, thus providing even lighting from all directions surrounding the camera or other image capture device, and allowing, for example, the lighting frame assembly to follow the motion of the camera or other image capture device as it is moved. An example of additional components allowing the camera mounting assembly 1801 to be secured to a camera are shown in FIGS. 19A and 19B. In particular, FIGS. 19A and 19B depict two halves 1902, 1912 of a camera clamp which may be joined together and attached to the elongated rod or arm 1832 of the camera mounting assembly 1801, arriving at a complete camera mounting assembly such as illustrated in FIG. 3 (i.e., camera mounting assembly 330) or, in more detail, in FIG. 22. The rectangular openings 1903, 1913 in the two halves 1902 and 1912, respectively, of the camera clamp allow it to be slid onto the elongated rod or arm 1832. A spring-loaded retention clip, as shown in FIG. 20, may be used to help secure the camera clamp to the elongated rod or arm 1832. In alternative embodiments, the camera clamp (comprising the combination of two halves 1902, 1912) may be permanently affixed and/or integrally formed with the elongated rod or arm 1832.

An attachment member, such as pre-molded clamping member 1916 shown in FIG. 19B, may be used to slide onto an appropriate feature of the camera (such as a Panavision® type motion picture camera), e.g., a rod or other feature of the camera. Other types of attachment members may be used, depending upon the particular nature of the camera or other image capture device. The camera mounting assembly 1801, in conjunction with the preferred camera clamp illustrated in FIGS. 19A and 19B, thereby allow a lighting frame assembly to be secured to a camera or other image capture device.

FIG. 23 is a diagram illustrating one technique for attaching a camera mounting assembly to a lighting frame. As shown in FIG. 23, a lighting frame 1302 may comprise a mounting assembly receptor 1320, similar to as described with respect to FIG. 3 and FIG. 15A-15B, for example. In connection with attaching a camera mounting assembly 2328, a spring 2305 is first positioned in the mounting assembly receptor 2320, atop of which is then placed a plunger 2308 (such as illustrated in FIG. 21). Then, the camera mounting assembly 2328 is attached, by, e.g., inserting the attachment member into the mounting assembly receptor 2320. In essence, the application of the attachment member to the mounting assembly receptor 2320 may be viewed analogously to inserting and twisting a "key" in a keyhole. The spring 2305 effectively locks the camera

mounting assembly **2328** in place against the back “key-plate” surrounding the keyhole, thus allowing the camera mounting assembly **2328** to be “twist-locked” into place. The assembly structure shown in FIG. **23** allows relatively easy attachment and detachment of the camera mounting assembly **2328**. Other attachment techniques may also be used.

Another embodiment of a camera mounting assembly, as may be used to attach a lighting frame to a camera or other image capture device, is illustrated in FIG. **27**, and various components thereof are illustrated individually in FIGS. **24**, **25** and **26**. With reference first to FIG. **24**, two halves **2415**, **2418** of a camera clamp may be joined together to form a main camera clamp body. the two halves **2415**, **2418** may be secured together by screws or any other suitable fastening means. A slot in the camera clamp body may be provided to allow placement of a thumbwheel **2604** (illustrated in FIG. **26**) which allows tightening of a clamping member **2437**. Several holes **2430** are provided in camera clamp portion **2415**, which receive corresponding protrusions **2511** from an attachment member **2501**, illustrated in FIG. **25**, which has a generally circular body portion **2519** with two wing-like protruding tabs **2586**. The completed camera mounting assembly **2701** appears as in FIG. **27**.

The tabs **2586** of the camera mounting assembly **2701** shown in FIG. **27** may be fitted into the two corresponding indentations **1524** in the ring-shaped top surface of the cylindrical housing of the mounting assembly receptor **1520** shown in FIG. **15**, as described previously with respect to the FIG. **22** camera mounting assembly. As before, the camera mounting assembly may be twisted in a clockwise direction to cause the tabs **2586** to slide through the slits adjacent to the indentations **1524** in the mounting assembly receptor **1520**, allowing the camera mounting assembly **2701** to be slid downward, then twisted in a counter-clockwise direction and locked into place in the mounting assembly receptor **1520**. The camera mounting assembly **2701** may be disengaged from the lighting frame portion **1501** by manually applying pressure to release the locking tabs and twisting the camera mounting assembly **2701** in the opposite (i.e., clockwise in this example) direction from that originally used to bring it into a locking position. The camera mounting assembly **2701** may then be raised upwards and twisted in a counter-clockwise direction to cause the tabs **2586** to slide back through the slits adjacent to the indentations **1524** in the mounting assembly receptor **1520**, thereby completely releasing the camera mounting assembly **2701**.

As noted previously, a variety of other means may alternatively be used to affix a camera mounting assembly **2701** of FIG. **27** to the lighting frame portion **1502**.

As with the camera mounting assembly **1801** shown in FIG. **18**, the camera mounting assembly of FIG. **27** functions to allow a lighting frame assembly to be secured to a camera or other image capture device, thus allowing, for example, the lighting frame assembly to follow the motion of the camera or other image capture device as it is moved. An attachment member, such as pre-molded clamping member **2437** shown in FIG. **24**, may be used to slide onto an appropriate feature, such as a rod or other feature, of the camera (for example, an Arri® type motion picture camera).

FIGS. **28** and **29** are diagrams of alternative embodiments of camera mounting assemblies having certain integral components. FIG. **28** illustrates a camera mounting assembly **2801** as may be used, for example, to secure a lighting frame to a Panavision® type camera. As shown in FIG. **28**, an attachment member **2838** (or “key”) connects with, and

integrally attaches to, a camera clamp plate **2802**, in a manner similar to that shown in FIG. **18**, but eliminating the elongated rod or arm shown therein. A pair of cylindrically-shaped lock lever “screws” **2851**, **2852** enable the camera mounting assembly **2801** to attach to an appropriate feature of the camera. Lock levers **2855**, **2856** connected to each of the lock lever screws **2851**, **2852** can be flipped (e.g., a quarter turn) in order to lock the screws **2851**, **2852** into place, thus securing the camera mounting assembly **2801** to the camera. The lock lever screws **2851**, **2852** can be flipped the opposite direction to unlock the screws **2851**, **2852** and thereby release the camera mounting assembly **2801** from the camera.

FIG. **29** illustrates a camera mounting assembly **2901** as may be used, for example, to secure a lighting frame to an Arri® type camera. As shown in FIG. **29**, an attachment member **2938** (or “key”) connects with, and attaches to, a camera clamp plate **2902**, by way of, e.g., screws **2940**. A cylindrically-shaped lock lever screw **2951** enables the camera mounting assembly **2901** to attach to an appropriate feature of the camera. A lock lever **2855** connected to the lock lever screw **2851** can be flipped (e.g., a quarter turn) in order to lock the screw **2851** into place, thus securing the camera mounting assembly **2901** to the camera. The lock lever screw **2851** can be flipped the opposite direction to unlock the screw **2851** and thereby release the camera mounting assembly **2901** from the camera.

Additional details of the particular lighting frame portion **1501** of FIGS. **15A** and **15B** are illustrated in FIGS. **16A** through **16E**. FIGS. **16A** and **16B**, for example, are diagrams showing an oblique view and a top view, respectively, of the backside of the lighting frame portion **1501** illustrated in FIGS. **15A** and **15B**. In FIGS. **16A** and **16B** can more clearly be seen, for example, the interior locking tabs **1567** and exterior locking tabs **1564** that can be used to secure the lighting frame portion **1501** to its corresponding half, as previously described with respect to FIG. **15C**. In FIG. **16C** is depicted a close-up illustration of the backside of the mounting assembly receptor **1520** and electrical socket **1515** illustrated from the opposite side in FIGS. **15A** and **15B**. In FIGS. **16D** and **16E** can be seen additional details of both the mounting assembly receptor **1520** (FIG. **16D**) and the interior locking tabs **1567** and exterior locking tabs **1564**. As shown in FIGS. **16D** and **16E**, the interior locking tabs **1567** may include a protruding locking member **1570** for securing the lighting frame portion **1501** to its counterpart by, e.g., snapping it into place, and the exterior locking tabs **1564** may likewise include protruding locking members **1568** having a similar function. The frame wall **1562** between the two nearby exterior locking tabs **1564** may be reinforced with a supporting rib **1569**, to provide added counter-force when the lighting frame assembly is put together.

The camera mounting assemblies shown in FIGS. **18**, **23**, **27**, **28** and **29** are merely examples of camera mounting assemblies that may be utilized in various embodiments described herein. Other camera mounting assemblies may be specifically adapted to the particular camera of interest. The mounting assembly receptor **320** (or **1520**) may in one aspect be viewed as a universal receptor, allowing different camera mounting assemblies to be connected to the lighting frame, provided that they are compatible with the mounting assembly receptor (such as the example shown in FIGS. **15A**–**15BB** and elsewhere). A single lighting frame may thus be used with any of a variety of different cameras or other image capture devices. Although examples have been explained with respect to certain camera types (that is, a Panavision® camera or an Arri® camera), the camera may

be of any type, whether for film or still photograph, and may be based upon either analog or digital imaging techniques. Moreover, while preferred dimensions are illustrated in some of the figures, the mounting assemblies and components thereof may be of any appropriate size and shape.

Further description will now be provided concerning various preferred light elements as may be used in connection with one or more embodiments as disclosed herein. While generally discussed with reference to FIG. 3, the various light elements described below may be used in other embodiments as well. When embodied as LEDs, the low power lamps **305** typically will emit light at approximately 7400–7500 K degrees when at full intensity, which is white light approximating daylight conditions. However, LEDs of a different color, or one or more different colors in combination, may also be used. FIG. 9 is an energy spectrum graph showing a typical frequency distribution (in terms of light wavelength) of light output from white-light, low voltage LEDs, and illustrating a main peak at about 600 nanometers. A color correction mechanism, such as a color correction gel or lens filter, may be used to alter the color of the LED light. For example, the LED light could be converted to “Tungsten daylight” (similar in hue to an incandescent bulb) by use of a color gel or colored lens. A diffusion lens or filter may also be used, by itself or in conjunction with a color gel or colored lens, to diffuse or soften the outgoing light. A diffusion lens or filter may be formed of, e.g., clear or white opaque plastic, and may be configured in a ring-shaped pattern of similar dimension to the light frame **302** to facilitate mounting thereon. FIG. 17, for example, shows a diagram of an opaque, ring-shaped cover **1701** as may be used in connection with the lighting frame assembly depicted in FIG. 3 or FIG. 4.

FIG. 7 is a more detailed diagram of a light segment **792** (e.g., an array) as may be used, for example, in connection with the lighting frame **302** shown in FIG. 4. The light segment **792** may correspond to each of the individual light segments **306** shown in FIG. 4, and the various light elements (i.e., LEDs) **790** in FIG. 7 may correspond to the individual low power lamps **305** shown in FIG. 3. FIG. 7 illustrates a straight row of LEDs **790** as may comprise the lighting segment **790**. Although fifteen LEDs **790** are illustrated in the example shown in FIG. 7, any number of LEDs **790** may be used, subject to physical space limitations and lighting intensity requirements. In addition, a set of filtering lenses **794** (which are preferably formed as a single, collective lens comprised of individual lens elements **795** connected together) may be placed over the light segment **792** as shown, such that each lens element **795** is positioned in the light path of one of the LEDs **790**. The overall effect can be, for example, to focus or spread the light according to a specifically desired pattern, such as the exemplary light pattern **796** shown in FIG. 7. A variety of other light filtering techniques may also be used.

FIG. 8 is a diagram illustrating the effect of a filtering lens element (e.g., wave guide) **876** on an individual light element (e.g., LED) **872**. As shown in FIG. 8, light **874** emanates from the LED **872** in a generally even pattern, but can be focused or otherwise filtered by the filtering lens element **876**. FIG. 7 illustrates an example of collectively filtering all of the LEDs **790** of the light segment **792**.

Returning now to the general diagram of a lighting effects system **201** illustrated in FIG. 2 (although the following comments will apply to various other embodiments such as the lighting frame assembly shown in FIGS. 3 and 4), the LEDs or other low power lamps **205** may be operated at a standard direct current (DC) voltage level, such as, e.g., 12

volts or 24 volts, and may be powered by a power source **210** controlled by a power controller **212** such as generally shown in FIG. 2. The power source **210** can generally comprise a standard electrical outlet (i.e., nominal 110 volt AC power line), although in various embodiments the power source **210** could also be a battery having sufficient current to drive the LEDs or other low power lamps **205**. In some embodiments, the power controller **212** may be omitted, and the lighting frame **202** may be connected directly to the power source **210**.

Block diagrams of two different types of power controllers **212** as may be used in various embodiments as described herein are illustrated in FIGS. **10A** and **10B**, respectively. With reference to FIG. **10A**, a first type of power controller **1012** has an input for receiving an AC power source **1003**, and outputs a plurality of power wires **1047** preferably through a cable (e.g., cable **213** shown in FIG. 2) for connection to the lighting frame **202**. The power controller **1012** may further comprise a power converter **1020**, the nature of which depends upon the type of power source **210**. If the power source is an AC source, the power converter **1020** may comprise an AC-to-DC converter and appropriate step-down power conversion circuitry (e.g., a step-down transformer). On the other hand, if the power source is a DC source (e.g., a battery), the power converter **1020** may comprise a DC-to-DC converter, if necessary. The design and construction of power converters is well known in the field of electrical engineering, and therefore is not described herein in detail.

The power converter **1020** is preferably connected to a plurality of switches **1022**, which may be solid state devices (e.g., transistors) or analog devices (e.g., relays), each switch controlling power delivered by the power converter **1020** to one of the wires **1047** output by the power controller **1012**. A switch selector **1042** controls the on/off state each switch (or group) in the set of switches **1022**. A manual interface **1030** is provided to allow operation of the switches **1022** according to manual selection. The manual interface **1030** may include a master power switch **1031**, switch controls **1032**, and, optionally, an effects selector **1033**. The switch controls **1032** may include an individual manual switch, button or other selection means for each individual switch provided in the set of switches **1022**, or else may comprise a control mechanism (such as knob or reduced number of manual switches, buttons or other selection means) for selecting groups of switches **1022** according to pre-designated arrangements. As but one example, assuming a light arrangement such as shown in FIG. 4, a knob provided as part of the switch controls **1032** could have a first setting to select all of the light segments **306**, a second setting to select every other light segment **306**, and a third setting to select every fourth light segment **306**, thus providing options of 100%, 50% and 25% total light output. The switch selector **1042** would then convert each knob setting to a set of control signals to the appropriate switches **1022**, which in turn would control power to the wires **1047** supplying power to the light segments **306**.

As another example, the switch controls **1032** could include an individual manual switch, button or other selection means for each light segment **306** or group of light segments **306** in the lighting arrangement.

An effects generator **1043** may optionally be included in the power controller **1012**, along with an effects selector **1033** which forms part of the manual interface **1030**. The effects generator **1043** may provide the ability to create various lighting effects, such as, e.g., dimming, strobing, pulsation, or pattern generation. The effects selector **1043**

may affect all of the switches **1022** simultaneously, or else may affect individual switches or groups of switches **1022**, depending upon the desired complexity of the lighting effects. Dimming may be accomplished, for example, through a manual control knob or multi-position switch on the effects selector **1033**. The dimming control may be electronically implemented, for example, in an analog fashion through a variable resistive element, or in a digital fashion by detecting the selected manual setting and converting it to selecting power setting through, e.g., selected resistive elements in a resistive ladder circuit. Where the switches **1022** are implemented, for example, as controllable variable amplifiers, the selectable resistance may be used to control the output of each amplifier and thereby the light output by the amplifier's respective light segment **306** (or group of light segments **306**). In other embodiments, the dimming control may optionally be applied to the output of switches **1022**. Where dimming control is applied collectively, it may be implemented by applying the selected dimming control level to the incoming signal from the power converter **1020**, which is supplied to all of the switches **1022** collectively. Other variations for implementing dimming control are also possible and will be apparent to those skilled in the art of electrical engineering.

Strobing may be accomplished by generating an oscillating signal and applying it as a control signal either upstream or downstream from the switch selector **1042**. The frequency of oscillation may be selectable via a manual knob, switch or other selection means as part of the effects selector **1033**.

Pattern generation may be accomplished by, e.g., manual selection from a number of predefined patterns, or else through an interface allowing different pattern sequencing. Patterns may include, for example, strobing or flashing different groups of light segments **306** (given the example of FIG. 3) in a predefined sequence (which may be a pseudo-random sequence, if desired), strobing or flashing different low power lamps **305** of the light segments **306** in a predefined (or pseudo-random) sequence, gradually dimming or brightening the light segments **306** (individually, in groups, or collectively), or various combinations of these effects.

Alternatively, rather than providing a separate effects selector **1033**, certain effects may be combined with the switch controls **1032**. For example, a dimmer switch (knob) could be used to both activate a light segment **306**, or group of light segments **306**, and also control light output via rotation of the dimmer switch (knob).

FIG. 10B is a block diagram showing another example of a power controller **1052** as may be used, for example, in the lighting effects system **200** of FIG. 2 or other embodiments described herein. Like the power controller **1012** shown in FIG. 10A, the power controller **1052** shown in FIG. 10B includes a power source input **1053** connected to a power converter **1060**. It further includes a set of switches **1062** receiving power from the power converter **1060**, and providing power to individual wires **1097** which are conveyed, preferably by cable, to the lighting frame assembly **201** of the lighting effects system **200**. The power controller **1052** also includes a switch selector **1072**, which may comprise, for example, a set of registers which provide digital signals to the switches **1062** to control their on/off state.

The power controller **1052** includes a processor **1074** which may be programmed to provide various lighting effects by manipulating the switch selector **1072** (for example, by changing values in registers which control the on/off states of the switches **1062**). The processor **1074** may

interface with a memory **1075**, which may comprise a volatile or random-access memory (RAM) portion and a non-volatile portion (which may comprise, e.g., ROM, PROM, EPROM, EEPROM, and/or flash-programmable ROM), the latter of which may contain programming instructions for causing the processor **1074** to execute various functions. The memory **1075** may be loaded through an I/O port **1076**, which may include an electrical serial or parallel interface, and/or an infrared (IR) reader and/or bar code scanner for obtaining digital information according to techniques well known in the field of electrical engineering and/or electro-optics. An interface **1080** may also be provided for programming or otherwise interfacing with the processor **1074**, or manually selecting various lighting effects options through selectable knobs, switches or other selection means, as generally explained previously with respect to FIG. 10A. The processor-based control system illustrated in FIG. 10B may also include other features and components which are generally present in a computer system.

In operation, the processor **1074** reads instructions from the memory **1075** and executes them in a conventional manner. The instructions will generally cause the processor **1074** to control the switch selector by, e.g., setting various digital values in registers whose outputs control the switches **1062**. The programming instructions may also provide for various lighting effects, such as dimming, strobing, pulsation, or pattern generation, for example. To accomplish dimming, the processor **1074** may be programmed select binary-encoded values to load into registers of the switch selector **1072**, which in turn select a variable resistance value which controls the output from each individual or group of switches **1062**. To accomplish strobing, the processor **1074** may be programmed to turn the switches **1062** on and off according to a predesignated pattern dictated by the programming instructions. The processor **1074** may make use of one or more electronic timers to provide timing between on and off events. The programming instructions may provide that the switches **1062** are turned on and off according to designated sequences, thus allowing the capability of pattern generation via the processor **1074**. As mentioned before, patterns may include, for example, strobing or flashing different groups of light segments **306** (given the example of FIG. 3) in a predefined (or pseudo-random) sequence, strobing or flashing different low power lamps **305** of the light segments **306** in a predefined (or pseudo-random) sequence, gradually dimming or brightening the light segments **306** (individually, in groups, or collectively), or various combinations of these effects.

Although the lighting frame **302** and lighting arrangement illustrated in FIG. 3 provides various advantages, other lighting frames and other lighting arrangements may also be used in a lighting effects system, and may be employed in connection with various techniques as described herein.

Another embodiment of a lighting frame **1101**, for example, is illustrated in FIG. 11. The lighting frame **1101** shown in FIG. 11 may be used in connection with a lighting effects system **201** such as shown in and previously described with respect to FIG. 2, and may be constructed according to general principles described previously with respect to FIGS. 15A–15C and 16A–16E. As shown in FIG. 11, a lighting frame **1101** is generally ring-shaped and has an opening **1107** through which a camera or other image capture device can view. On the lighting frame **1101** may be mounted a plurality of lamps **1112**. In the embodiment shown in FIG. 11, the lamps **1112** may be embodied as slim, narrow fluorescent “cold cathode” tubes with an internal

phosphorous coating emitting visible light of certain wavelength (for example, a color temperature of around 3200 deg. K or 5500 deg. K, both of which temperatures are commonly used in film and photography applications). FIG. 14 is a graph illustrating an example of a spectral distribution of light (in terms of light wavelength) in accordance with such a lighting effects system. The lamps 1112 are preferably oriented as illustrated in FIG. 11—that is, in a radial pattern, emanating from a centerpoint 1119 of the opening 1107 in the middle of the lighting frame 1101. Where embodied as cold cathode tubes, the lamps 1112 may be of any suitable size, such as, e.g., 3 to 10 millimeters in diameter and 25 to 250 millimeters in length.

Preferably, the lamps 1112 are controllable such that they can produce higher intensity or lower intensity light, and/or can be turned on or off in selected groups to adjust the overall light level provided by the lighting system. One possible means for controlling the light intensity of lamps 1112 is illustrated in FIG. 13. As shown therein, a light control system 1301 includes a selector switch 1310 which has a plurality of settings 1312, each of the settings 1312, in this example, providing a different combination of lamps 1112 (shown as elements 1322 in FIG. 13). By way of illustration, a first setting may illuminate all of the lamps 1322; a second setting may illuminate every other lamp 1322; and a third setting may illuminate every fourth lamp 1322, in each case providing a relatively even distribution of light but of a different overall intensity. For example, if 24 lamps were used, then the first setting would illuminate all 24 lamps, the second setting would illuminate 12 of the 24 lamps, and the third setting would illuminate six of the 24 lamps. The settings may correspond to any desired combination of lamps 1112. For example, each setting may be designed to control an equal number of lamps 1112, but in a different combination. The settings may be selected by any type of analog or digital input means (e.g., a manual knob, a set of switches or buttons, or a programmable interface), and any number of settings or programmable patterns may be offered.

Power for the lighting control system 1301 may be supplied by a battery 1305, which may have a voltage rating of, e.g., 12 volts. The battery 1305 may be rechargeable in nature. Alternatively, or in addition, power may be provided from an alternating current (AC) source, such as a standard 120 volt electrical outlet, connected to an AC-to-DC power converter. The output of the battery 1305 may be controlled by a dimmer switch (not shown), to allow the light intensity level of lamps 1312 to be reduced. Alternatively, or in addition, dimming and/or pulsing can be controlled through a pulse width modulation (PWM) circuit 1317. A first control means (e.g., a manual switch or knob, or programmable interface) (not shown) may be provided for dimming the lamps 1322. For example, a manual knob may control the conductance of a variable resistor, thus allowing more power or less power to reach the lamps 1322. In this way, the selected lamps 1322 may be brightened or dimmed, down to around 20% of their total light output. The PWM circuit 1317 may also, through a second control means (e.g., a manual switch or knob, or a programmable interface) allow pulsing of the light (i.e., a strobing effect) by adjustment of a pulse width modulation frequency. For example, a manual knob may control a variable resistive element, which in turn controls the width of pulses being generated by the PWM circuit 1317. Various techniques for generating pulses of different widths using a variable resistive element to control the selection of the width are well known in the electrical arts.

Energy is preferably delivered to the various lamps 1322 in FIG. 13 through a plurality of high frequency (HF) ballasts 1325, which are capable of converting low DC voltage of the battery 1305 to high DC voltage (e.g., 800 to 1500 volts) for starting the lamp, and mid-level voltage (e.g., 170 to 250 volts) for sustaining lamp operation. Other techniques may also be used to deliver energy to the lamps 1322.

While shown in a radial pattern in FIG. 13, the lamps 1322 (e.g., fluorescent tubes) may also be arranged in other patterns, such as patterns similar to those depicted, for example, in FIGS. 30A, 30B and 30C.

FIG. 12 is a diagram illustrating various options and accessories as may be used in connection with the lighting assembly frame depicted in FIG. 11. As shown in FIG. 12, the lighting frame 1101 may be augmented with a diffusion filter 1205 and/or a color filter 1215, which may, if desired, be secured into place through a clear plastic cover 1218 which locks or snaps onto the lighting frame 1101. Similar accessories may be utilized, for example, in connection with the lighting frame 302 illustrated in FIGS. 3 and 4.

It will be appreciated that, in various embodiments, a flexible, lightweight and functional lighting effects system is provided, whereby relatively uniform light may be used in illumination of a subject or area. The lighting effects system may, in various embodiments, allow a lighting frame to be secured to a camera or other image capture device, so as to permit the lighting system to be mobile and move in tandem with the camera or other image capture device, if desired. Also, in various embodiments, the lighting effects system may provide a variety of lighting patterns, including programmable patterns by which individual or groups of lights can be controlled for different lighting effects.

In various alternative embodiments, the lighting frame need not be ring-shaped in nature, as shown in FIGS. 3 and 4, for example, but could have other shapes as well. For example, the lighting frame may be square, hexagonal, octagonal, or other polygonal, or could, for instance, have a partially polygonal shape. Preferably, the lighting frame is relatively thin, as compared to its overall size, although it need not be. Also, the lighting frame preferably has a hole generally centered therein to allow a camera or other image capture device to view through the frame, although in some embodiments a viewing hole may not be present. The lighting frame is preferably made of a lightweight, durable material such as plastic and/or lightweight metal (e.g., aluminum), optionally anodized, although in various embodiments it can be made of other materials as well, including any type of metal, wood, plastic, or combination thereof.

Other variations may pertain to the manner of attaching the lighting frame to a camera or other image capture device. Rather than using a single mounting bracket or assembly, for example, multiple mounting brackets or assemblies may be used. Also, the mounting bracket or assembly may be permanently attached or affixed to the lighting frame, and may be, for example, retractable or foldable for convenience of transportation.

While preferred embodiments of the invention have been described herein, many variations are possible which remain within the concept and scope of the invention. Such variations would become clear to one of ordinary skill in the art after inspection of the specification and the drawings. The invention therefore is not to be restricted except within the spirit and scope of any appended claims.

What is claimed is:

- 1. A wide area lighting effects system comprising:
  - a frame comprising a mounting surface, said frame defining an opening positioned substantially in the center of said mounting surface;
  - a plurality of low power lights arranged on said mounting surface, said lower power lights oriented so as to distribute light over a wide area; and
  - a mounting bracket for attaching said frame to a camera such that the camera is positioned to view through the opening within said frame;
 wherein said frame comprises a mounting assembly receptor, and  
 wherein said mounting bracket comprises an attachment member adapted to secure to said mounting assembly receptor, and a camera clamp adapted to secure the mounting bracket to the camera.
- 2. The wide area lighting effects system of claim 1, wherein said frame is substantially ring-shaped, and wherein said opening is circular in shape.
- 3. The wide area lighting effects system of claim 2, wherein said low power lights are arranged in a plurality of concentric circles on said mounting surface, radiating outward from a centerpoint of said ring-shaped frame.
- 4. The wide area lighting effects system of claim 1, wherein said low power lights comprise light-emitting diodes (LEDs) or light-emitting crystals (LECs).
- 5. The wide area lighting effects system of claim 4, wherein said LEDs or LECs are oriented perpendicular to said mounting surface.
- 6. The wide area lighting effects system of claim 4, further comprising a variable control for electronically controlling intensity levels of said low power lights.
- 7. The wide area lighting effects system of claim 6, wherein the intensity levels of said low power lights are collectively controllable.
- 8. The wide area lighting effects system of claim 6, wherein the intensity levels of said low power lights are individually or groupwise controllable.
- 9. The wide area lighting effects system of claim 4, wherein a plurality of said low power lights are filtered so as to produce colorized light.
- 10. The wide area lighting effects system of claim 4, further comprising a programmable processor controlling the on/off states and light intensity levels of said low power lights.
- 11. The wide area lighting effects system of claim 10, wherein said programmable processor controls the on/off states and light intensity levels of said low power lights according to a pattern dictated by pre-programmed instructions.
- 12. The wide area lighting effects system of claim 4, further comprising a plurality of switches connecting a power source to said low power lights, and switch selector whereby the on/off states of said switches are selected, thereby controlling whether the low power lights are on or off.

- 13. A method of providing lighting over a subject area, comprising the steps of:
  - arranging a plurality of low power lights on the mounting surface of a frame, said frame defining an opening located substantially in the center of said mounting surface, said lower power lights oriented so as to distribute light over a wide area;
  - attaching a camera mounting assembly to said frame; and
  - attaching said mounting assembly to a camera such that the camera is positioned to view through the opening within said frame;
 wherein said frame comprises a mounting assembly receptor, and  
 wherein said mounting bracket comprises an attachment member adapted to secure to said mounting assembly receptor, and a camera clamp adapted to secure the mounting bracket to the camera.
- 14. The method of claim 13, wherein said frame is substantially ring-shaped, and wherein said opening is circular in shape.
- 15. The method of claim 14, wherein said step of arranging said plurality of low power lights on the mounting surface comprises the step of arranging said low power lights in a plurality of concentric circles on said mounting surface, radiating outward from a centerpoint of said ring-shaped frame.
- 16. The method of claim 13, wherein said low power lights comprise light-emitting diodes (LEDs) or light-emitting crystals (LECs).
- 17. The method of claim 16, wherein said LEDs or LECs are oriented perpendicular to said mounting surface.
- 18. The method of claim 16, further comprising a variable control for electronically controlling intensity levels of said low power lights.
- 19. The method of claim 18, further comprising the step of collectively controlling the intensity levels of said low power lights.
- 20. The method of claim 18, further comprising the step of individually or groupwise controlling the intensity levels of said low power lights.
- 21. The method of claim 16, further comprising the step of filtering a plurality of said low power lights so as to produce colorized light.
- 22. The method of claim 16, further comprising the step of controlling the on/off states and light intensity levels of said low power lights through a programmable processor.
- 23. The method of claim 22, wherein said programmable processor controls the on/off states and light intensity levels of said low power lights according to a pattern dictated by pre-programmed instructions.
- 24. The method of claim 16, further comprising the steps of connecting a power source to said low power lights through a plurality of switches, and controlling the on/off states of said switches through a switch selector, thereby controlling whether the low power lights are on or off.

\* \* \* \* \*

UNITED STATES PATENT AND TRADEMARK OFFICE  
**CERTIFICATE OF CORRECTION**

PATENT NO. : 6,749,310 B2  
DATED : June 15, 2004  
INVENTOR(S) : Pohlert et al.

Page 1 of 5

It is certified that error appears in the above-identified patent and that said Letters Patent is hereby corrected as shown below:

Delete Drawing Figs. on sheets 1, 2, 3 and 6 and substitute therefor the Drawing Sheets consisting of FIGS. 1, 4, 5, 6, 7, 8 and 11 as shown on the attached pages.

Column 18,

Lines 15 and 18, "mounting bracket" should be -- mounting assembly --.

Signed and Sealed this

Twenty-third Day of August, 2005

A handwritten signature in black ink on a light gray dotted background. The signature reads "Jon W. Dudas" in a cursive style.

JON W. DUDAS

*Director of the United States Patent and Trademark Office*

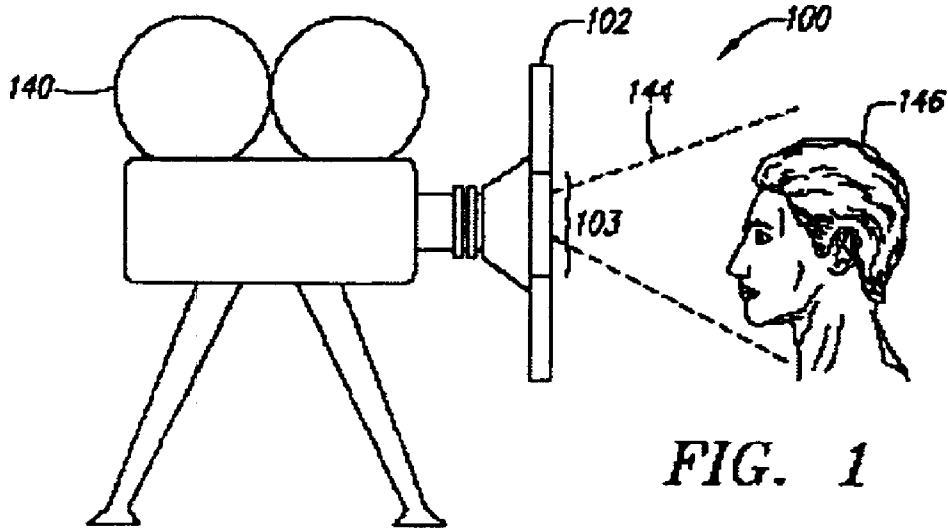

FIG. 1

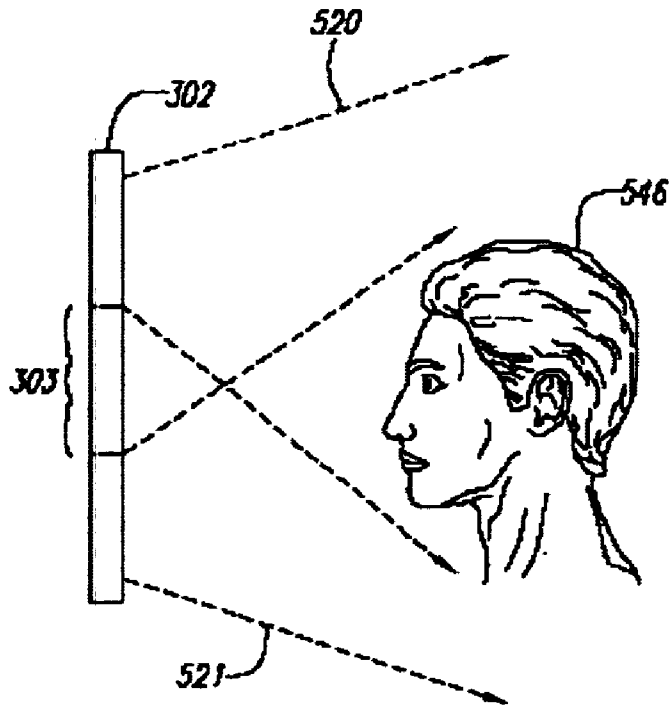
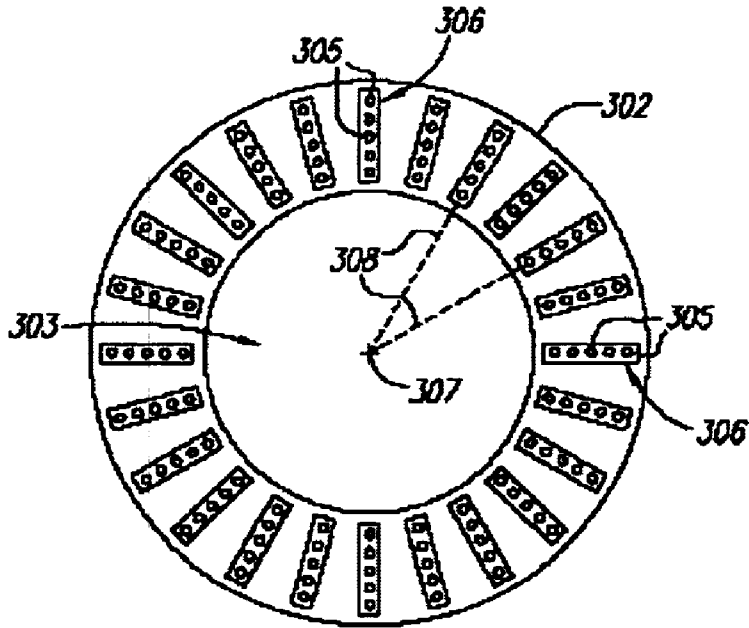

FIG. 5

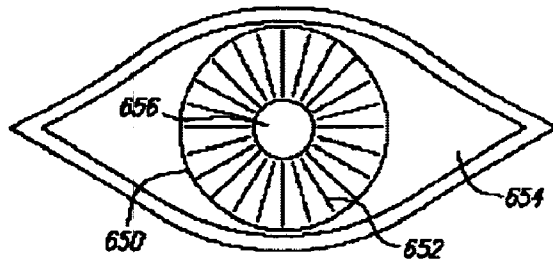

FIG. 6

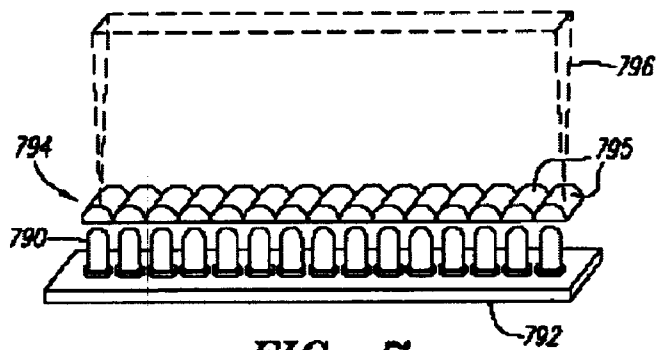

FIG. 7

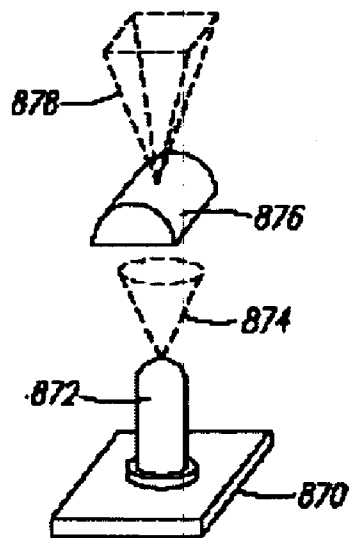
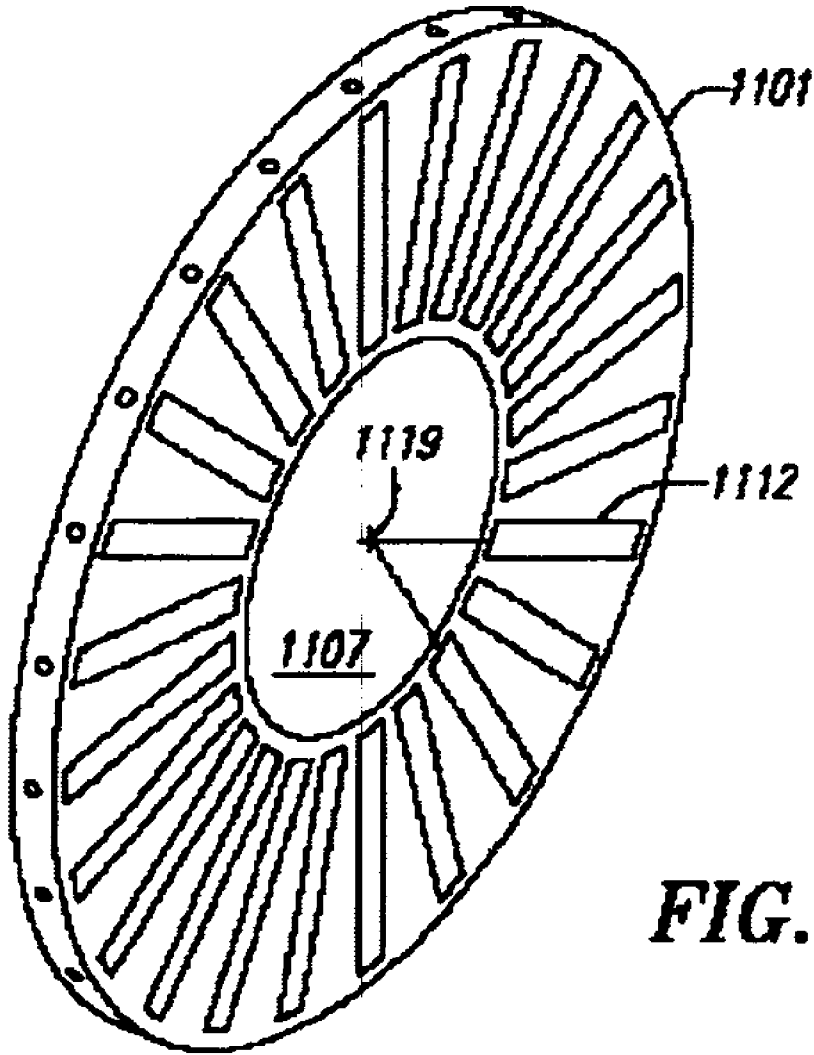

FIG. 8



**FIG. 11**