



US006719434B1

(12) **United States Patent**
Finn et al.

(10) **Patent No.:** **US 6,719,434 B1**
(45) **Date of Patent:** ***Apr. 13, 2004**

(54) **FOLDABLE LIGHT DIFFUSION BOX WITH FRAME ASSEMBLY**

4,616,293 A 10/1986 Baliozian 362/7
4,707,766 A 11/1987 Bertozzi et al. 362/11
4,719,545 A 1/1988 Cano 362/240

(76) Inventors: **Bruce L. Finn**, 3413 Rambla Pacifico, Malibu, CA (US) 90403; **Robert E. Lee**, 116 Mohawk, Topanga, CA (US) 90290

(List continued on next page.)

FOREIGN PATENT DOCUMENTS

GB 2223565 A 4/1990 F21V/1/14

(*) Notice: Subject to any disclaimer, the term of this patent is extended or adjusted under 35 U.S.C. 154(b) by 196 days.

OTHER PUBLICATIONS

Chimera News, vol. 18, No. 1, Chimera Photographic Lighting, 6-page newsletter, Boulder, Colorado, Jun. 1998.

Chimera Product Catalog, Chimera, Boulder, Colorado, May 1997.

International Cinematographers Guild Magazine, Vo. 70, No. 10, Oct. 1999, pp. L20-L21 Article by Bruce Finn.

This patent is subject to a terminal disclaimer.

(List continued on next page.)

(21) Appl. No.: **09/704,639**

(22) Filed: **Nov. 1, 2000**

Related U.S. Application Data

Primary Examiner—Alan Cariaso

Assistant Examiner—Ismael Negron

(74) *Attorney, Agent, or Firm*—Cislo & Thomas LLP

(63) Continuation-in-part of application No. 09/642,315, filed on Aug. 21, 2000, now Pat. No. 6,588,912, which is a continuation of application No. 09/146,063, filed on Sep. 2, 1998, now Pat. No. 6,106,125.

(57) **ABSTRACT**

(51) **Int. Cl.**⁷ **G03B 15/07**
(52) **U.S. Cl.** **362/11; 362/355; 362/367**
(58) **Field of Search** 362/11, 355, 367, 362/236, 237, 330, 317, 351, 362, 368, 372, 227, 240, 352, 358, 360, 7, 8, 16, 18, 235, 238, 239, 244, 246, 249, 250, 374, 375, 404, 408

A lighting project or device has a housing having multiple adjacent sides and a front, the housing being enclosed at least between par lamp and the diffusion element. Multiple par lights are mounted to a frame and positioned to send light out the front of the device. The box also has a diffusion element (frame) disposed proximate its front end, and even may have multiple elements preferably spaced apart. The element or elements receive the light from the par lighting instruments and diffuse it to provide a soft projected light from the device. In accordance with one aspect of the invention, this light may be used to provide diffused light as part of the key lighting for a stage or set, and may provide such soft projected lighting from a front (downstage) of the stage or set. The frame also supports the housing. The frame may be rectangular. The device may also have a soft shell, may hang overhead, on a stand or by a rotatable yoke, and may have lights fixed therein. The device may also have a rear cover.

(56) **References Cited**

U.S. PATENT DOCUMENTS

3,311,745 A * 3/1967 Gossner 362/227
3,509,334 A 4/1970 Michailov 240/81
4,295,187 A 10/1981 Shemitz 362/352
4,409,646 A 10/1983 Baliozian 362/319
4,428,030 A 1/1984 Baliozian 362/18
D272,656 S 2/1984 Parker D26/65
4,446,506 A 5/1984 Larson 362/17
4,490,776 A 12/1984 Kluch 362/16
4,504,888 A 3/1985 Rosenthal 362/18

84 Claims, 30 Drawing Sheets

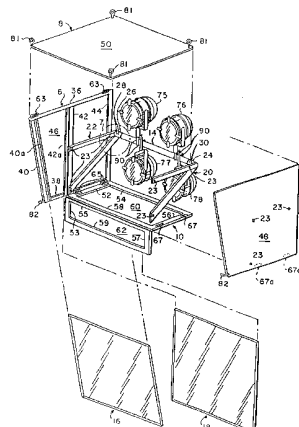

U.S. PATENT DOCUMENTS

4,757,425 A	7/1988	Waltz	362/18
4,788,628 A	11/1988	Farrall	362/18
4,855,874 A	8/1989	Waltz	362/16
4,998,189 A	3/1991	Guggemos	362/278
5,128,838 A	7/1992	Brandess	362/18
5,311,409 A	5/1994	King	362/17
5,651,602 A	7/1997	Tawil et al.	362/18
6,106,125 A *	8/2000	Finn et al.	362/11

OTHER PUBLICATIONS

“Box Theory,” ICG International Cinematographers Guild Magazine, Hollywood, California, Oct. 1999 (2 pages).
 6,000 Watt Molequartz® Six-Light Molepar®, Type 5761, Product Flyer, Hollywood, CA, Jun. 1996.
 6,000 Watt Six-Light Overhead Cluster (COOP), Type 20133, Product Flyer, Hollywood, CA, Sep. 1996.

2,000 Watt Molequartz® Spacelight, Type 7271, Mole-Richardson Lighting Catalog, Hollywood, CA, Jun. 27, 2002.
 Lights Up Industries Website excerpts, Los Angeles, CA, Jun. 12, 2002.
 The Fisher Light®, Website Excerpts, Fisherlight, North Hollywood, CA, Aug. 16, 2002.
 Kinoflo Website Excerpts.
 Broncolor Website Excerpts.
 “Dino-Light, Multi-Light, Mini-Brute” from Licht-Technik Vertriebs GmbH of Munich, Germany Website Excerpts, Jul. 12, 2002.
 Plume Website Materials, Jul. 12, 2002.
 Photoflex Website Materials, Jul. 12, 2002.

* cited by examiner

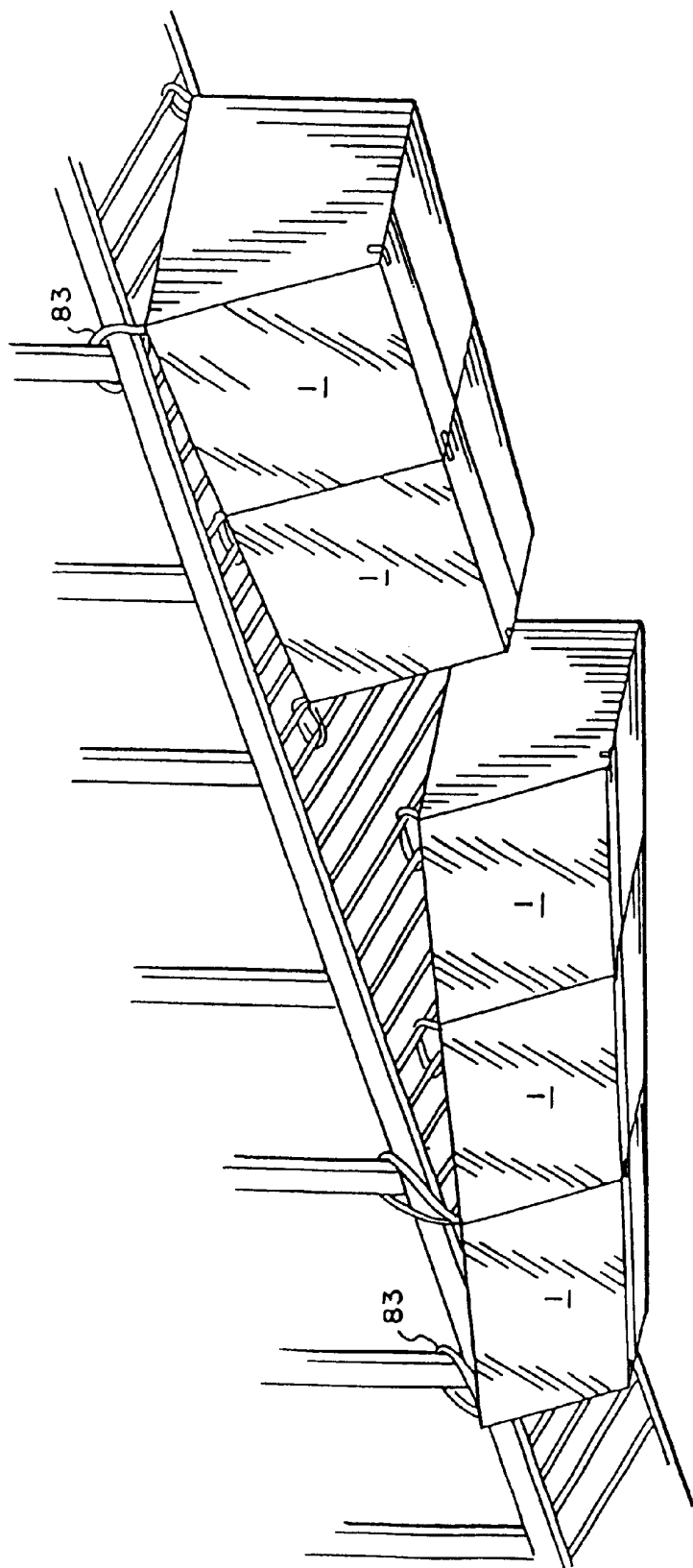
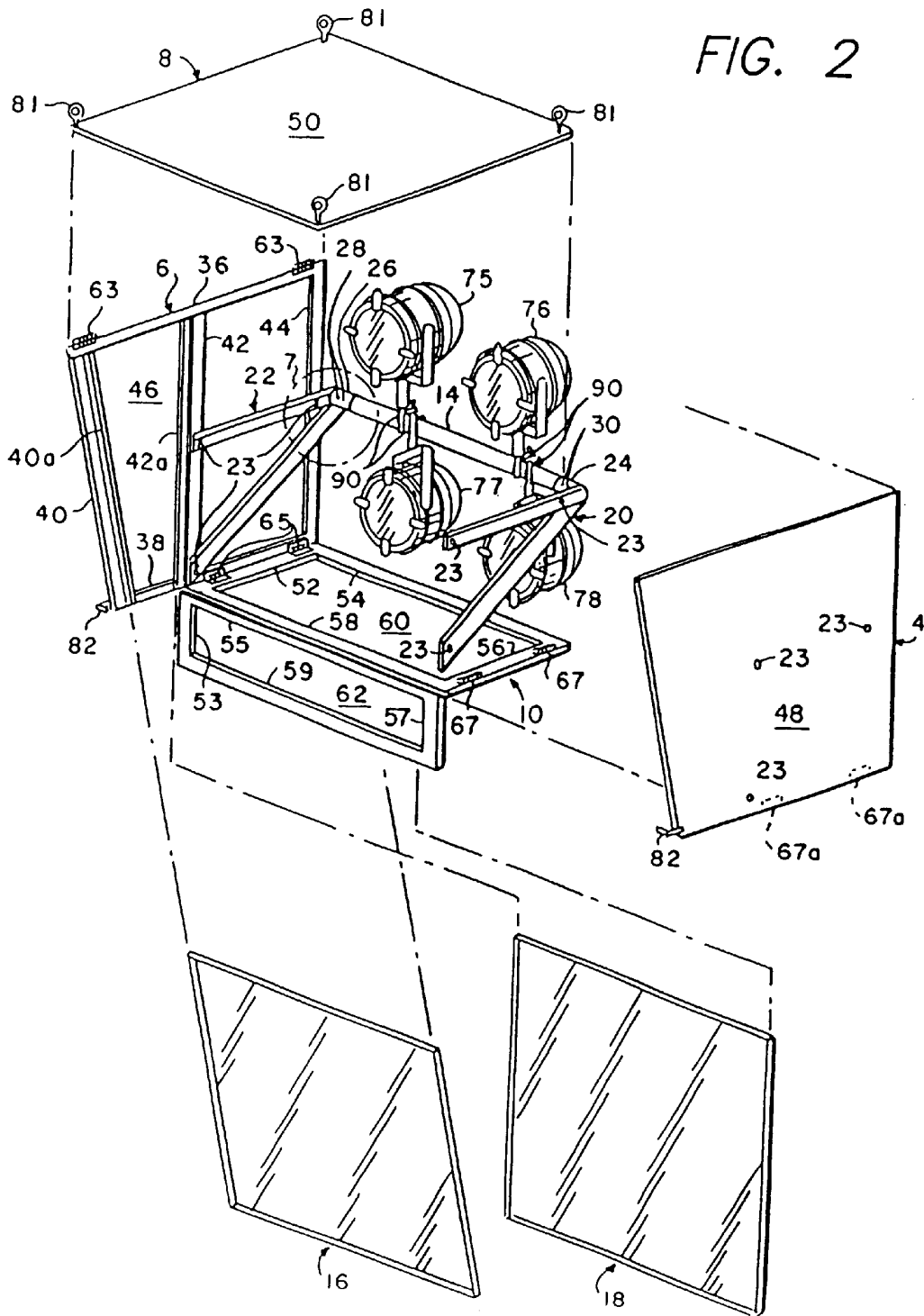

FIG. 1

FIG. 2



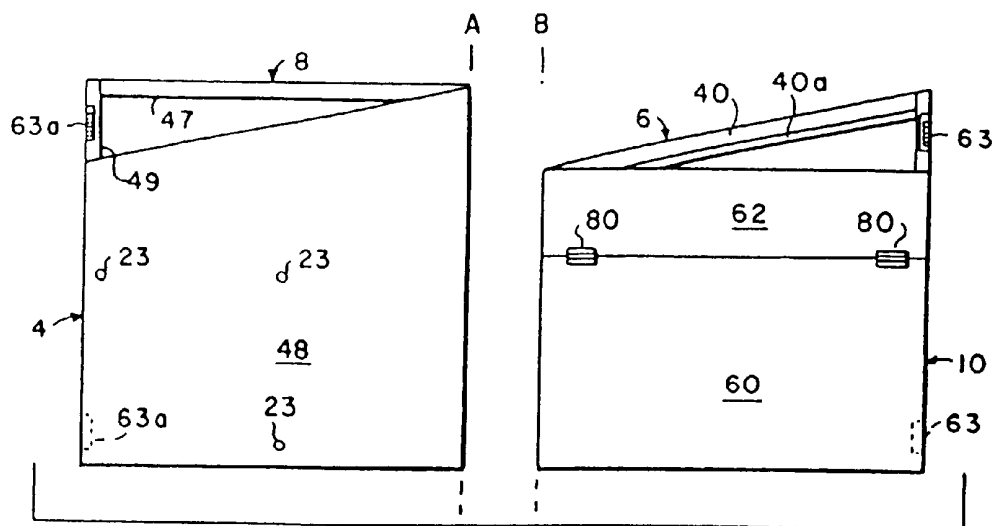

FIG. 3

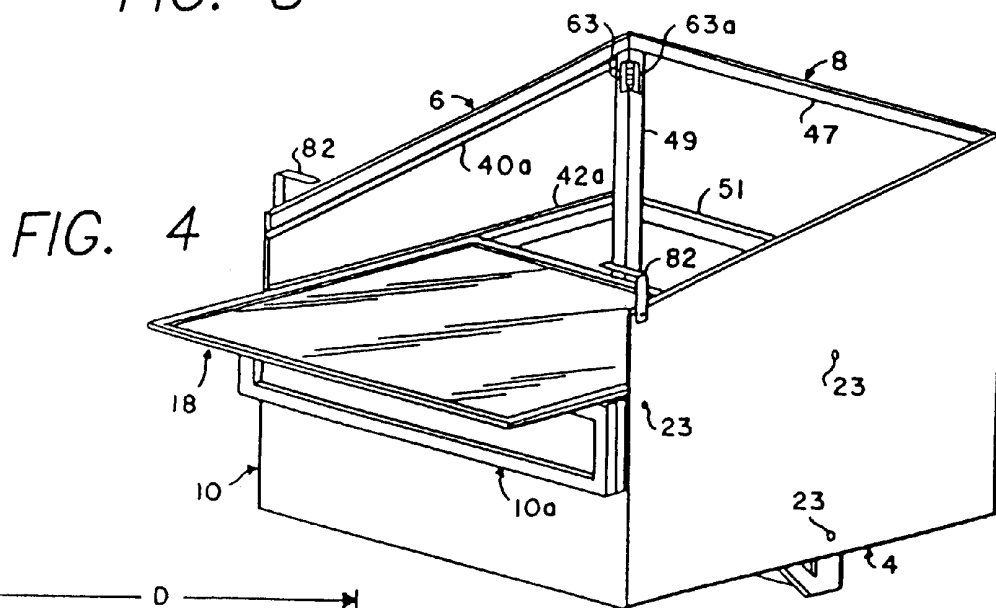

FIG. 4

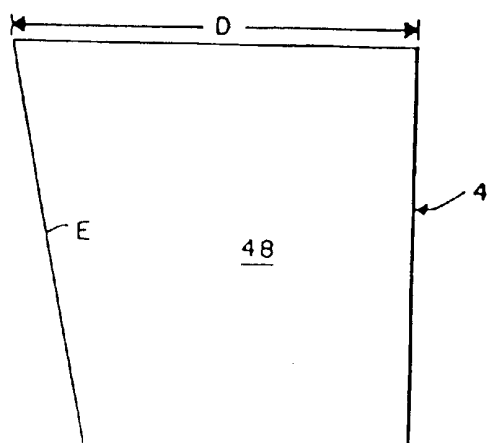

FIG. 5

FIG. 6

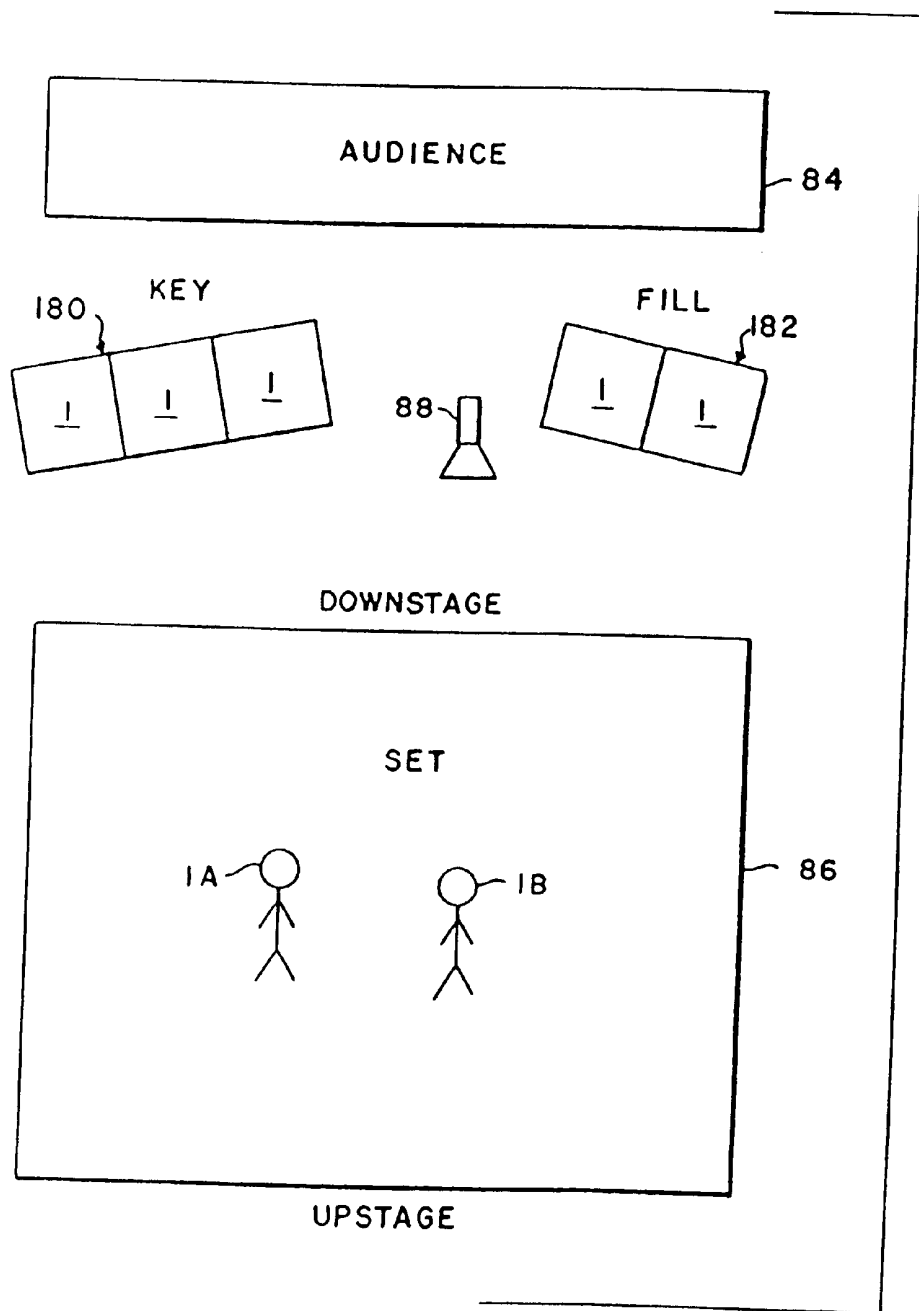
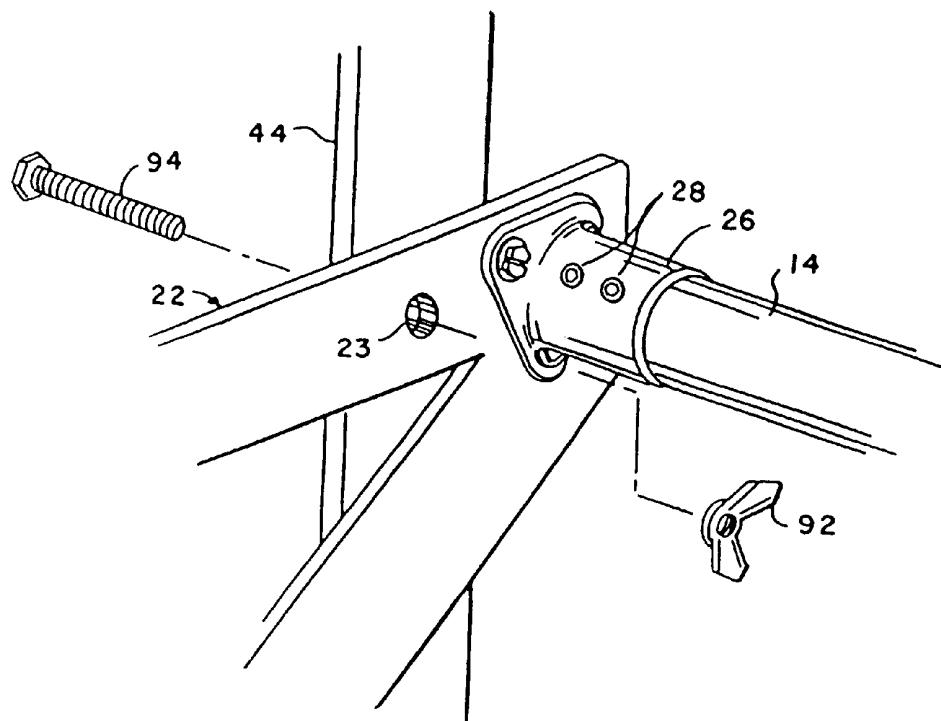

FIG. 7



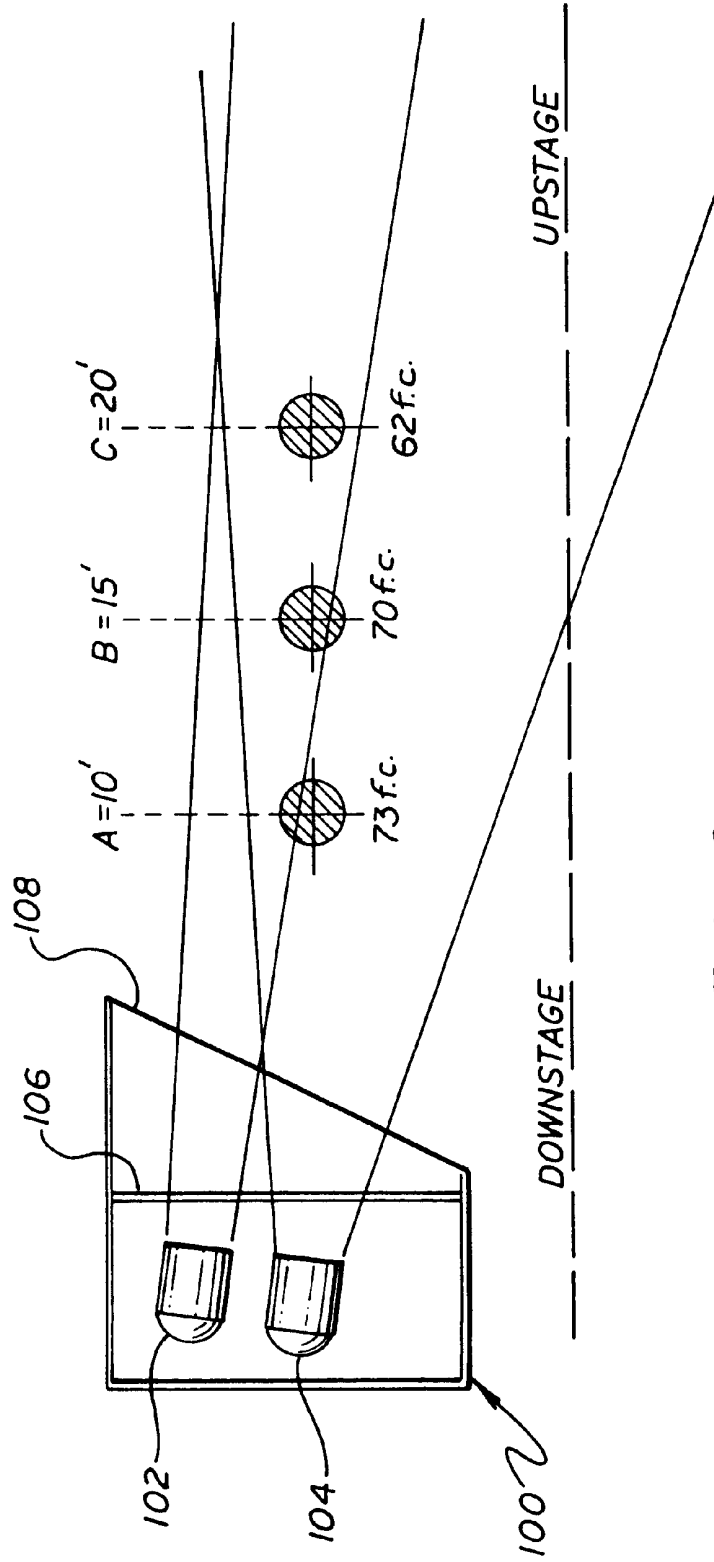

FIG. 8

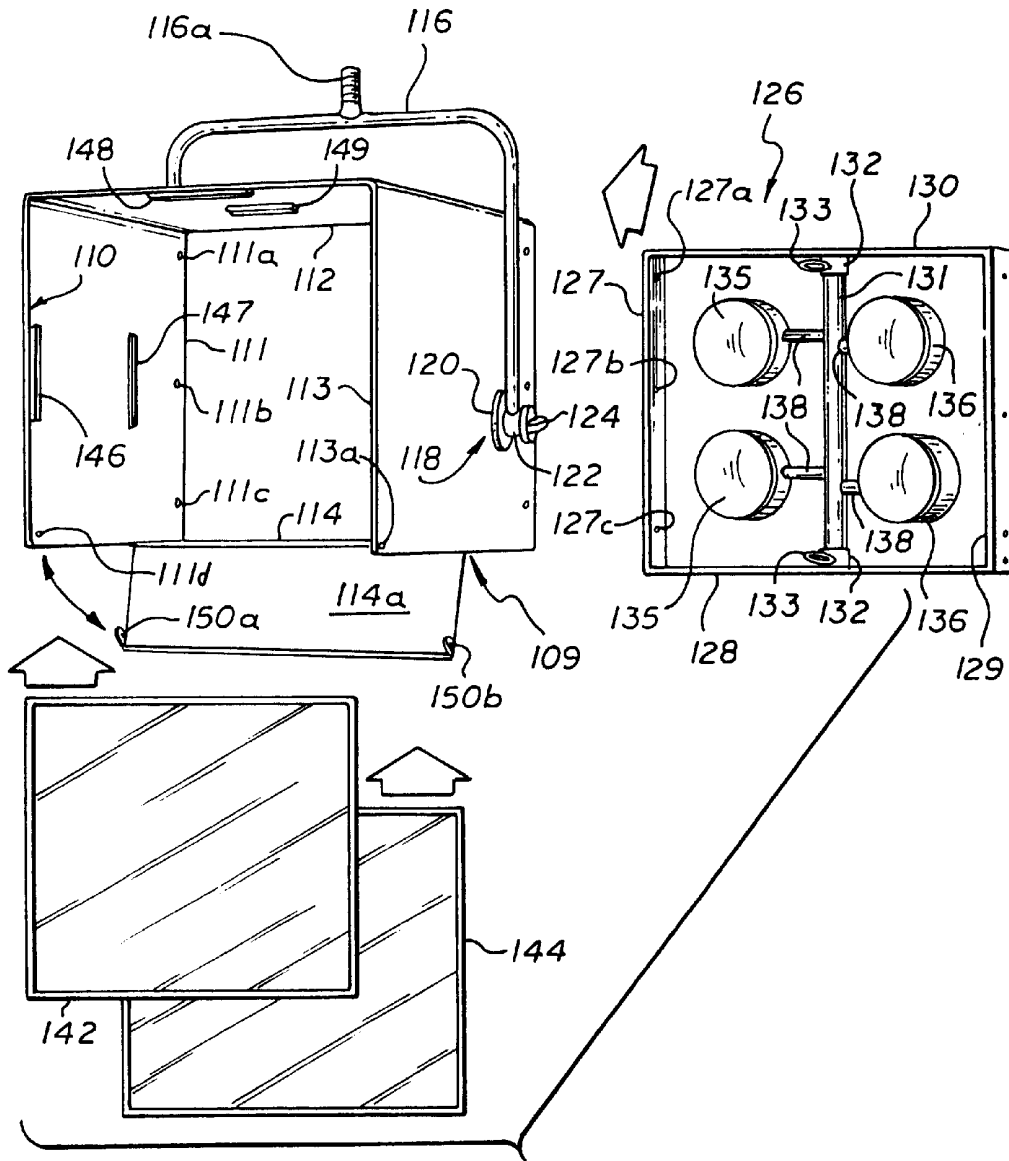

FIG. 9

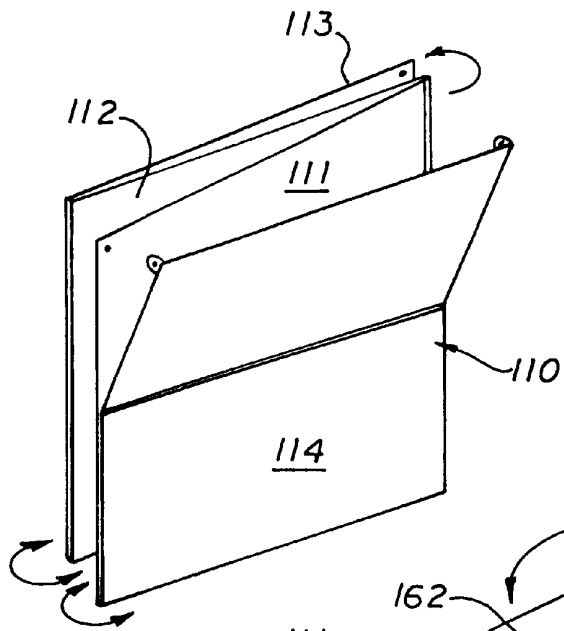

FIG. 12

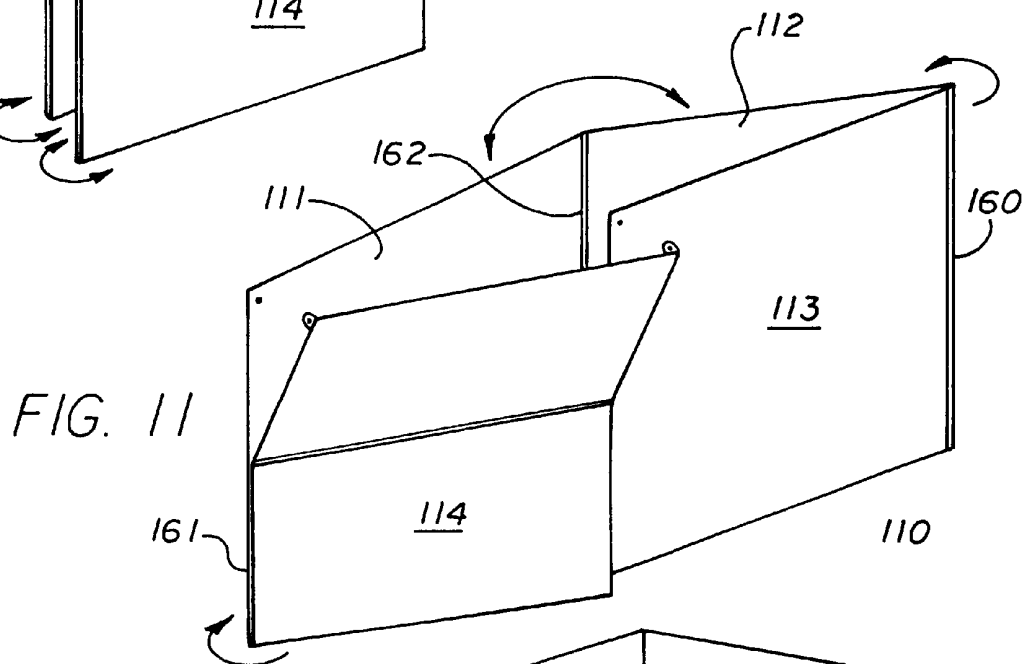

FIG. 11

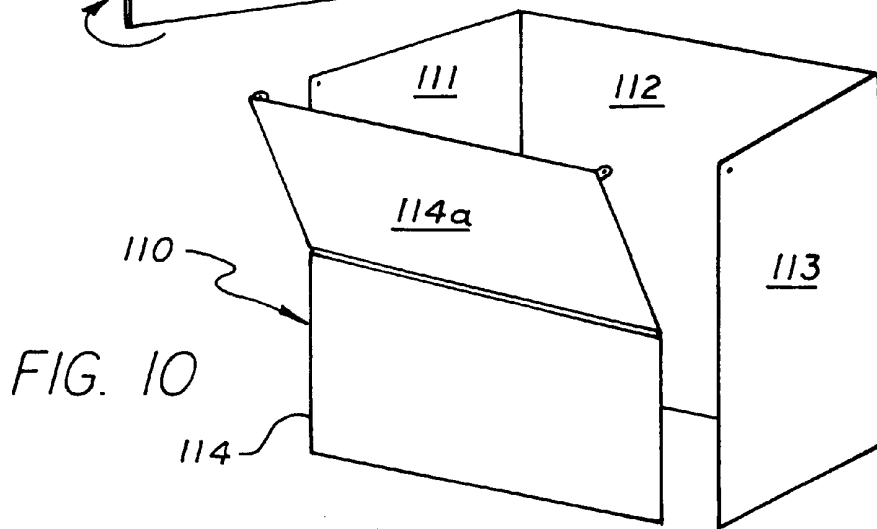

FIG. 10

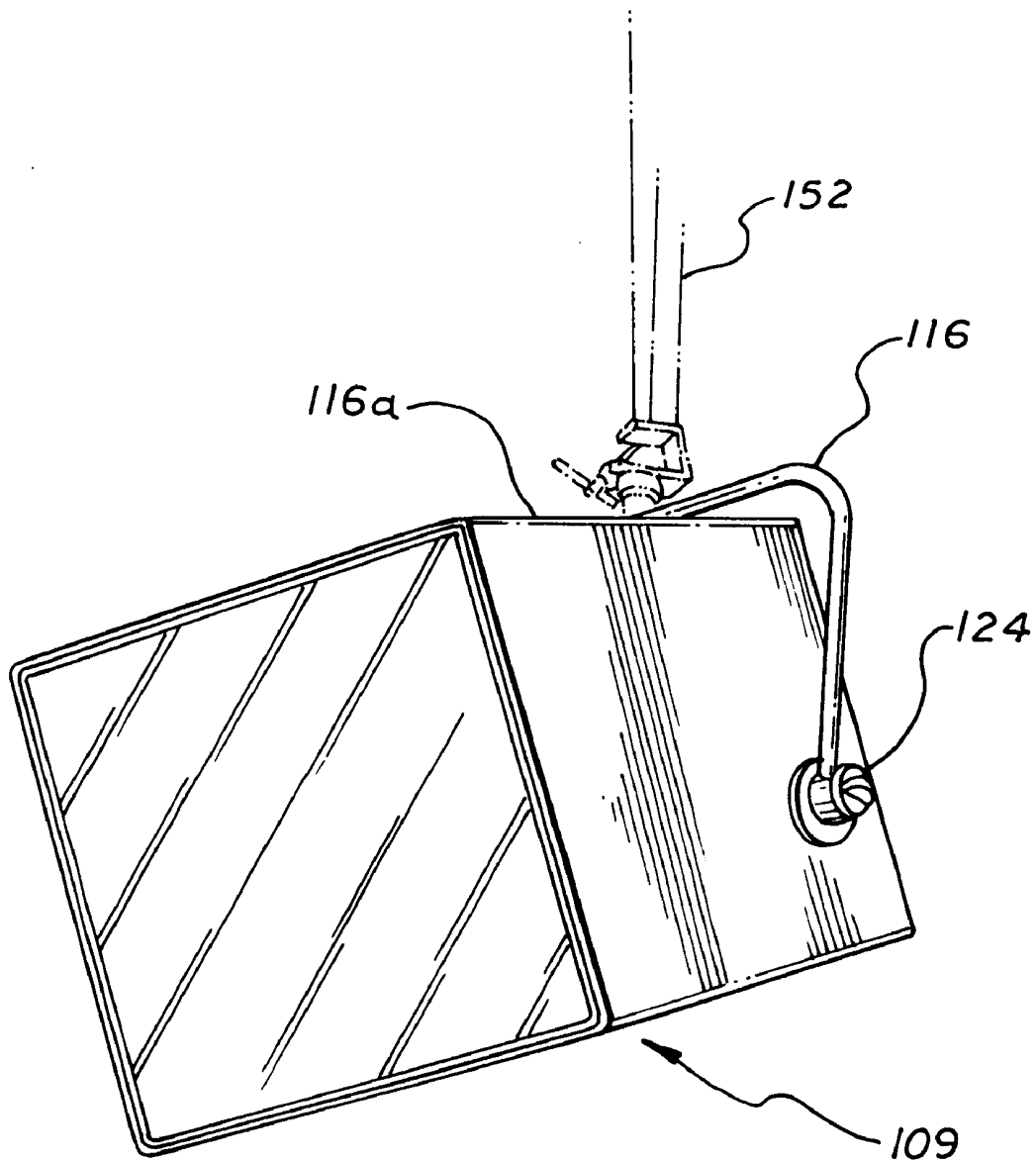
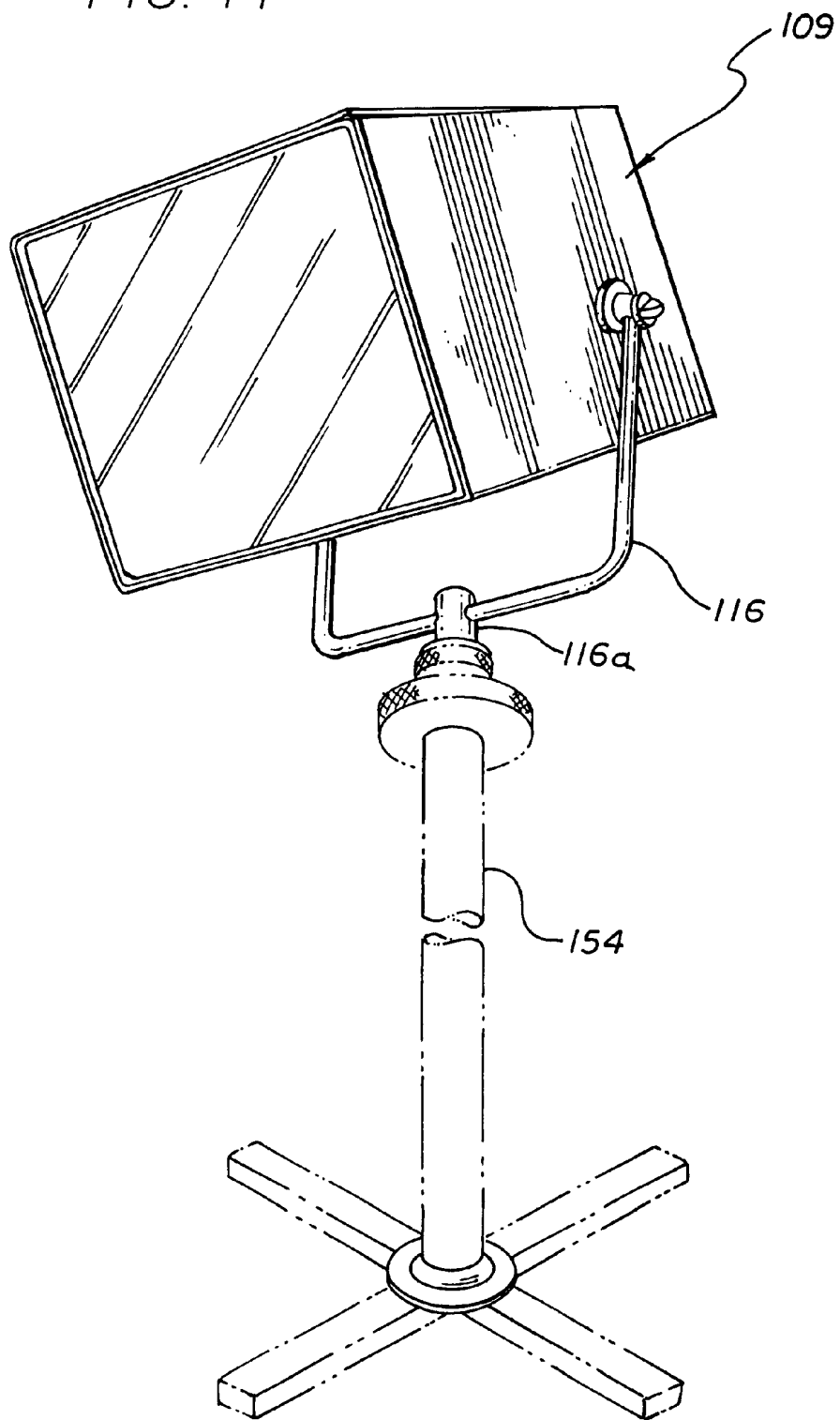

FIG. 13

FIG. 14



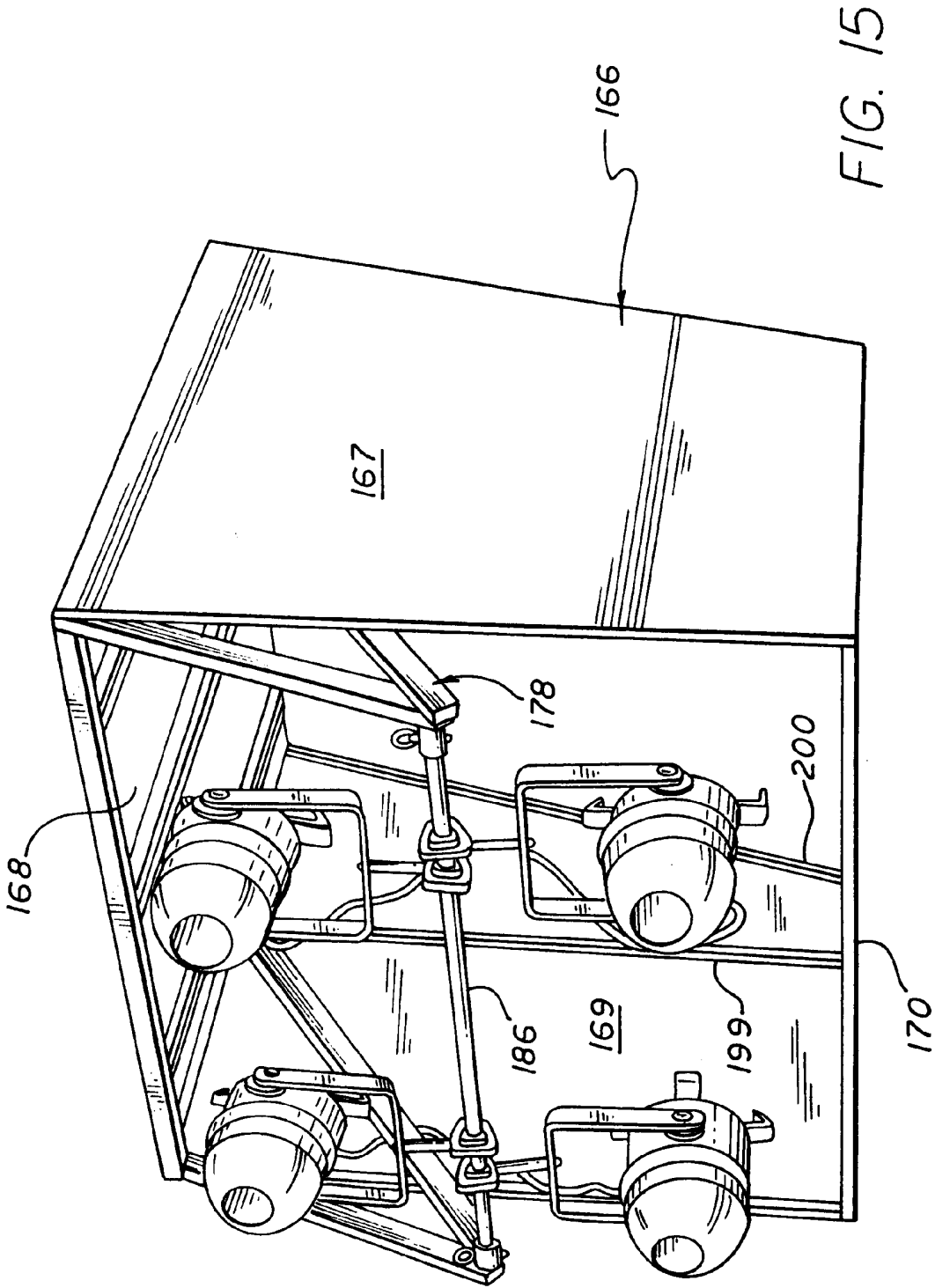
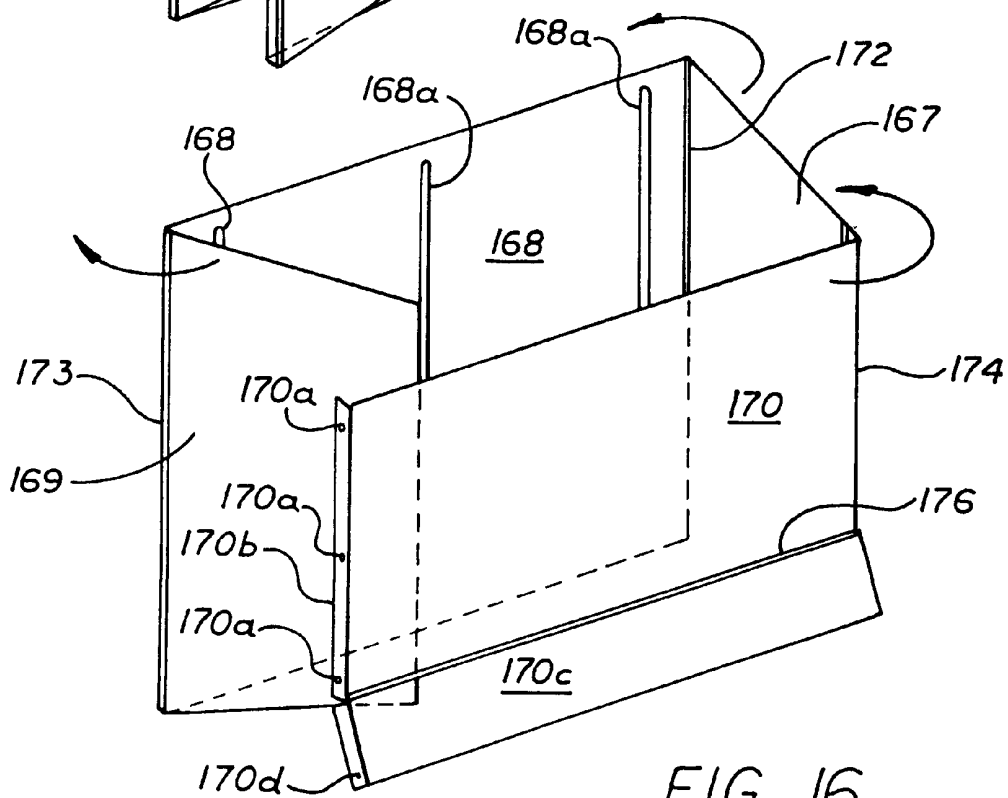
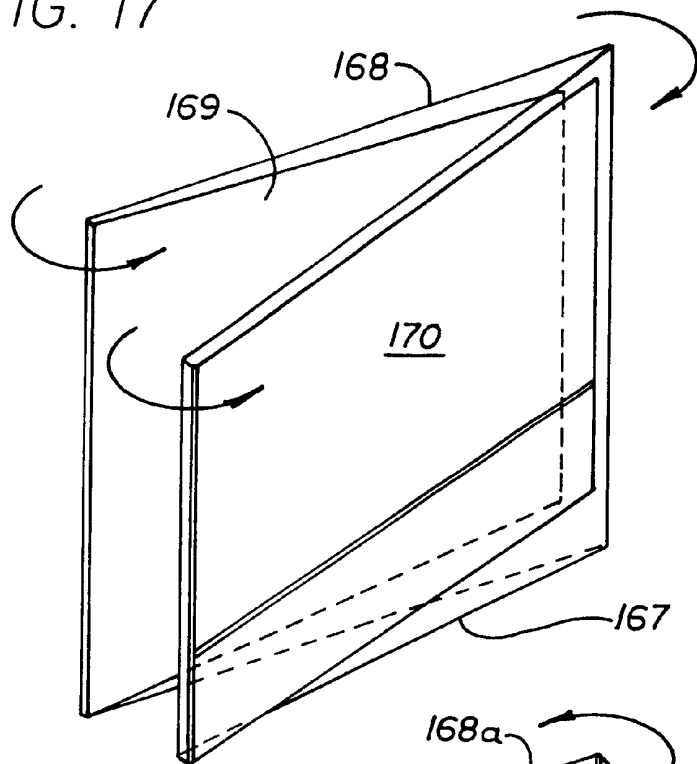

FIG. 15

FIG. 17



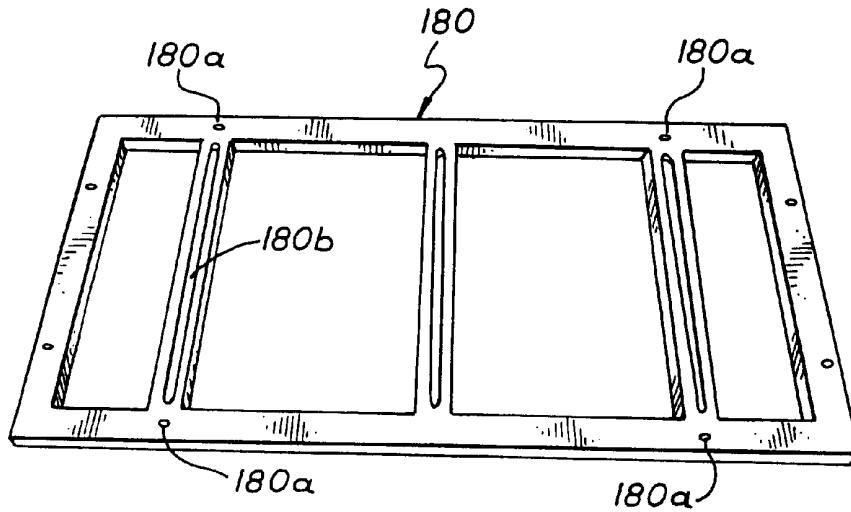

FIG. 18

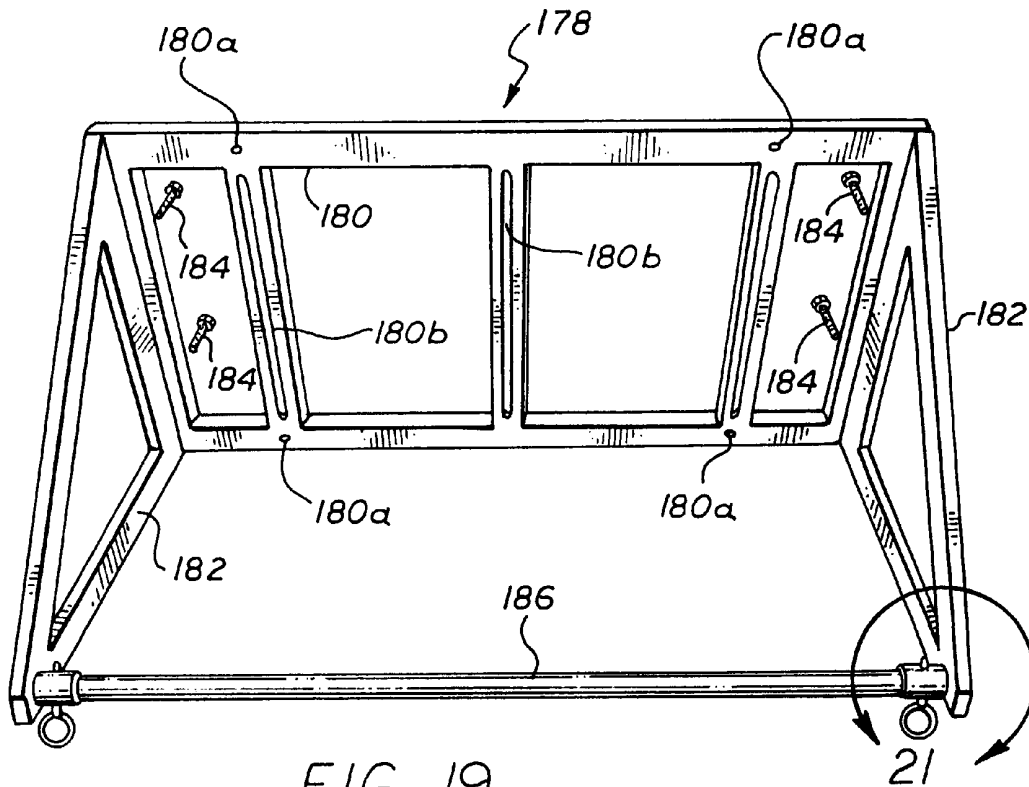

FIG. 19

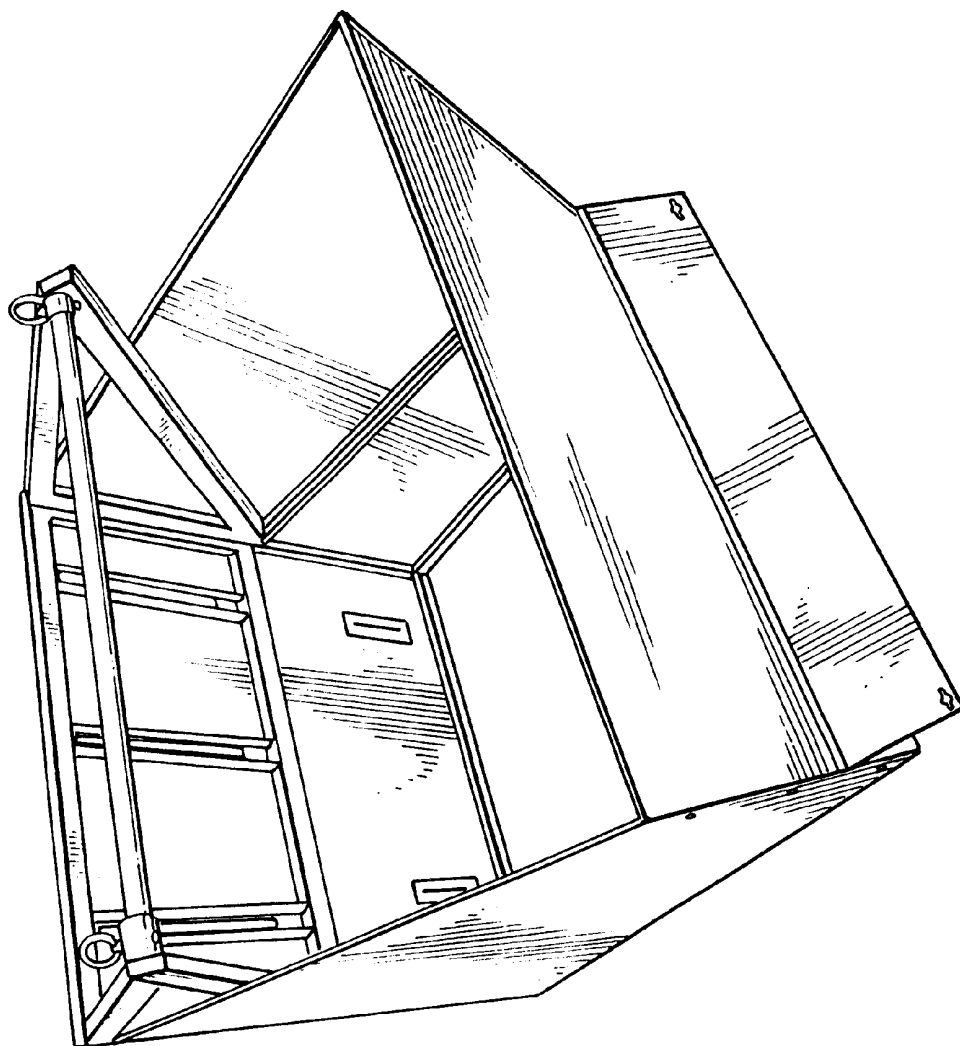

FIG. 20

FIG. 21

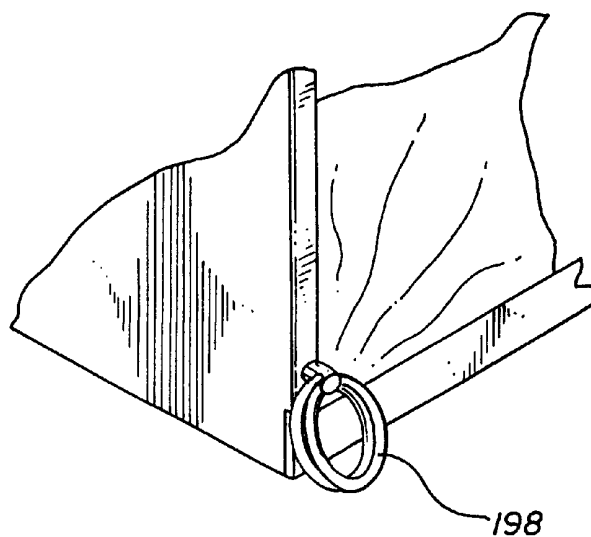
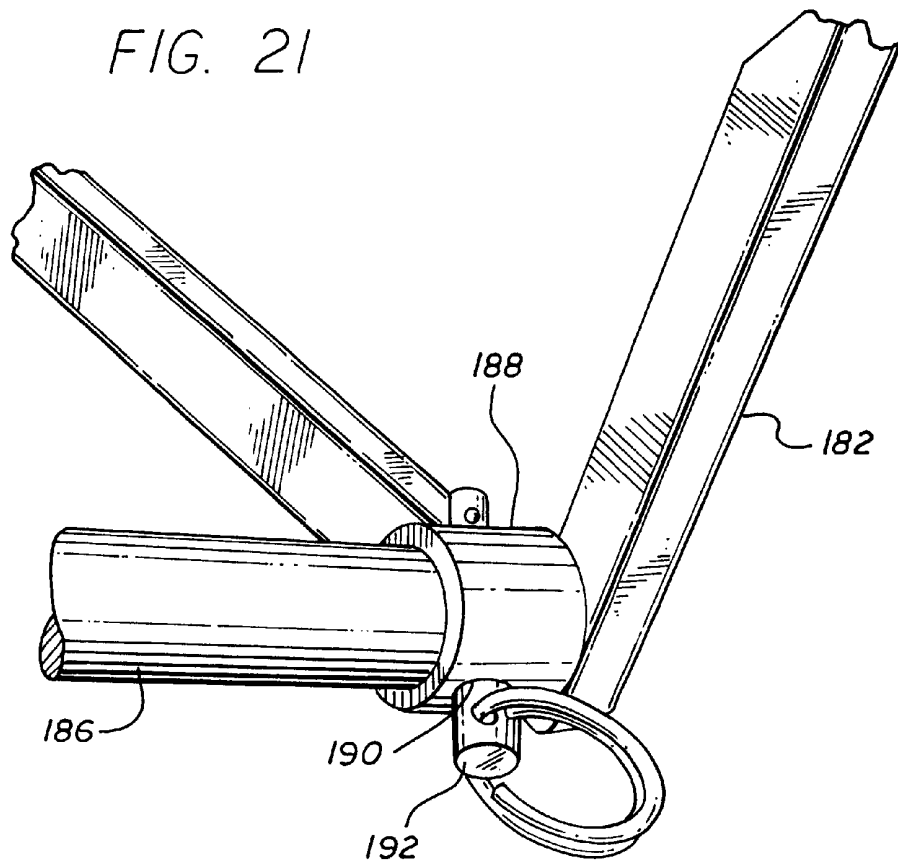

FIG. 22

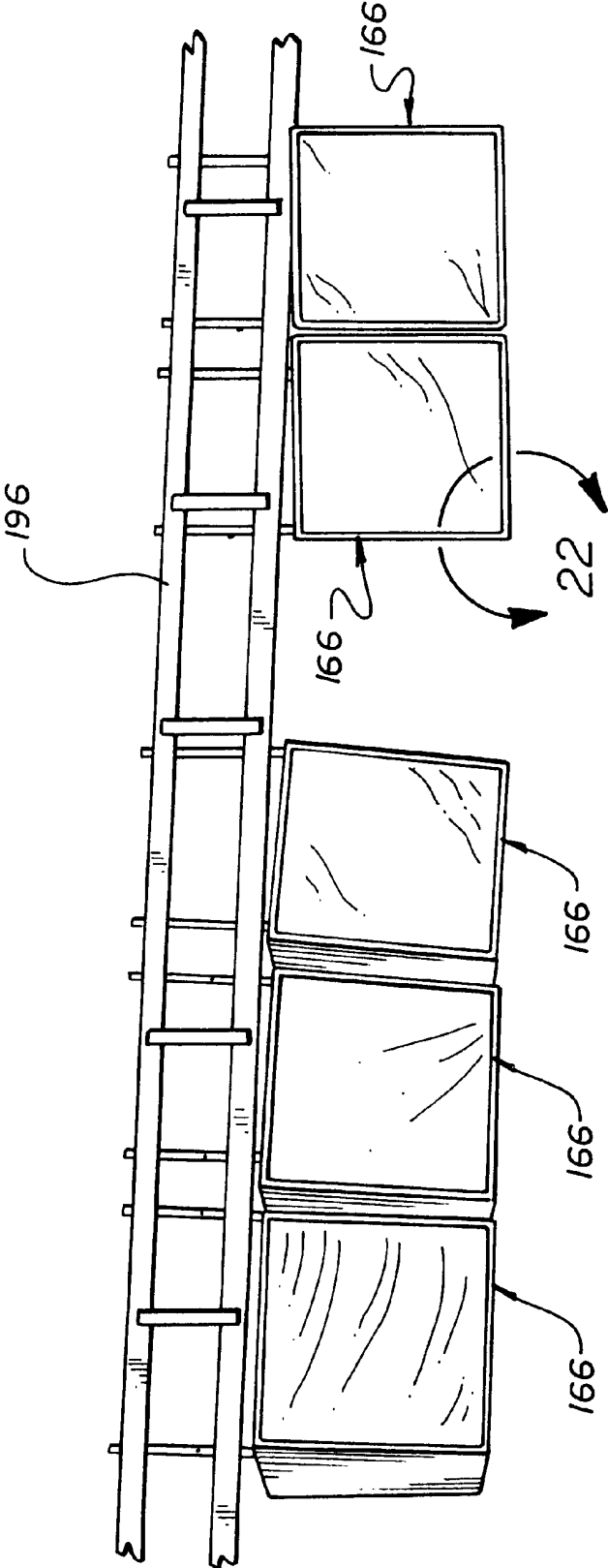

FIG. 23

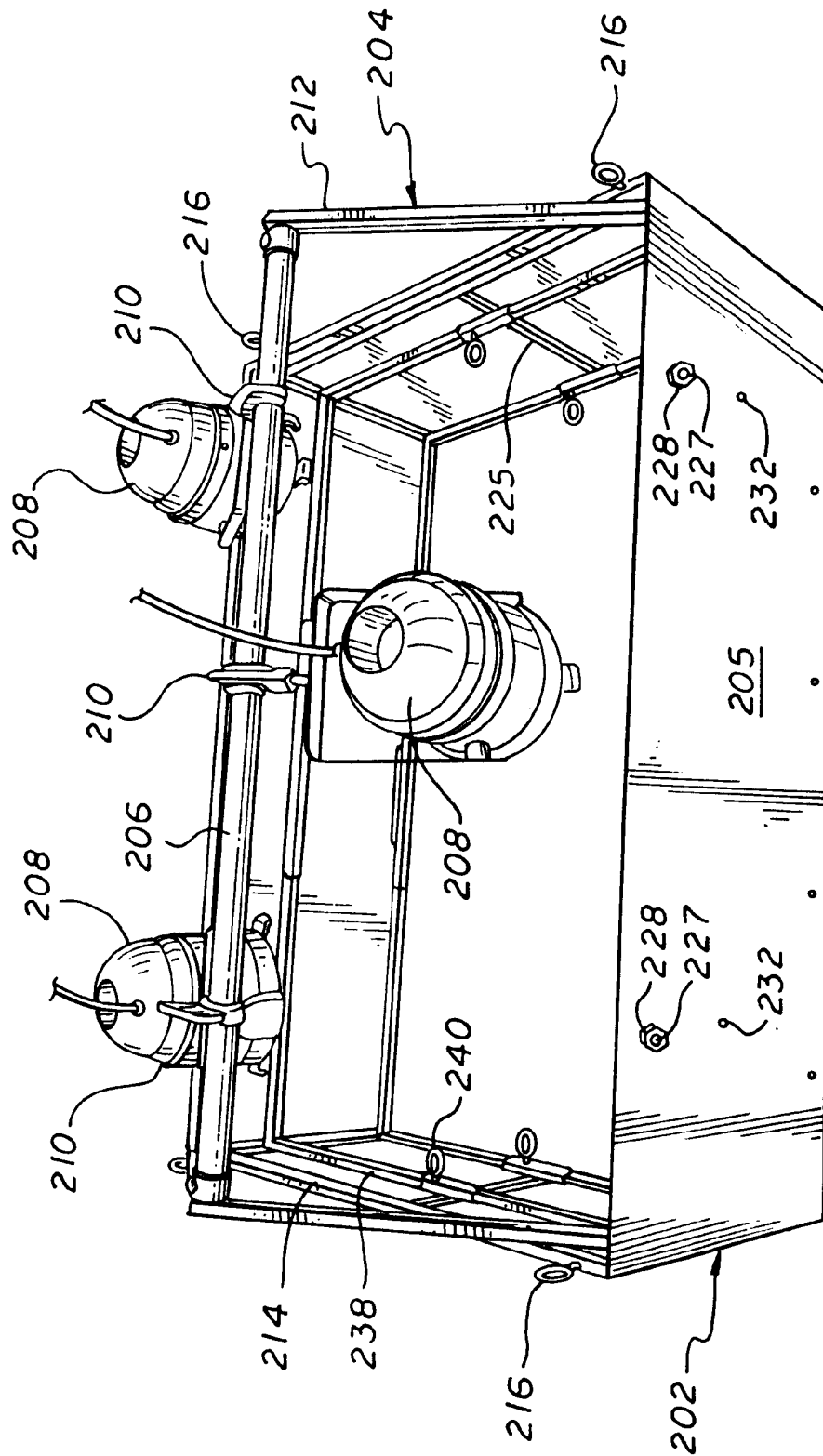

FIG. 24

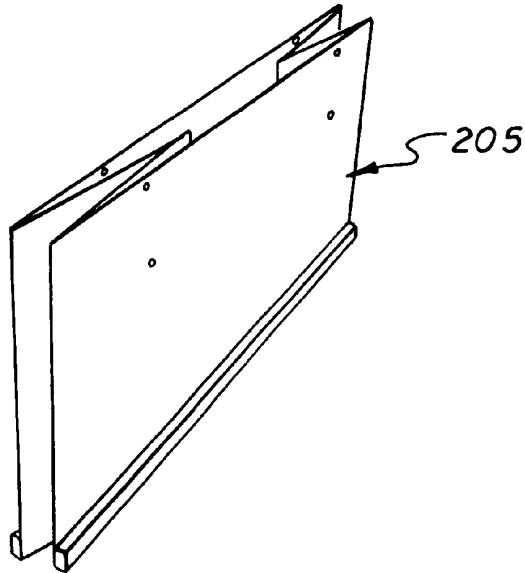

FIG. 27

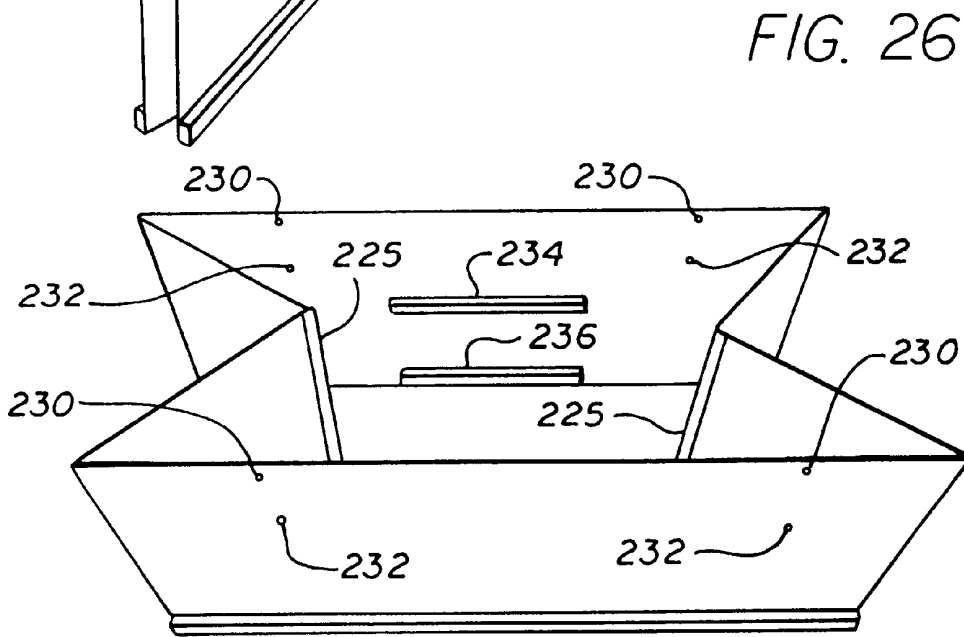

FIG. 26

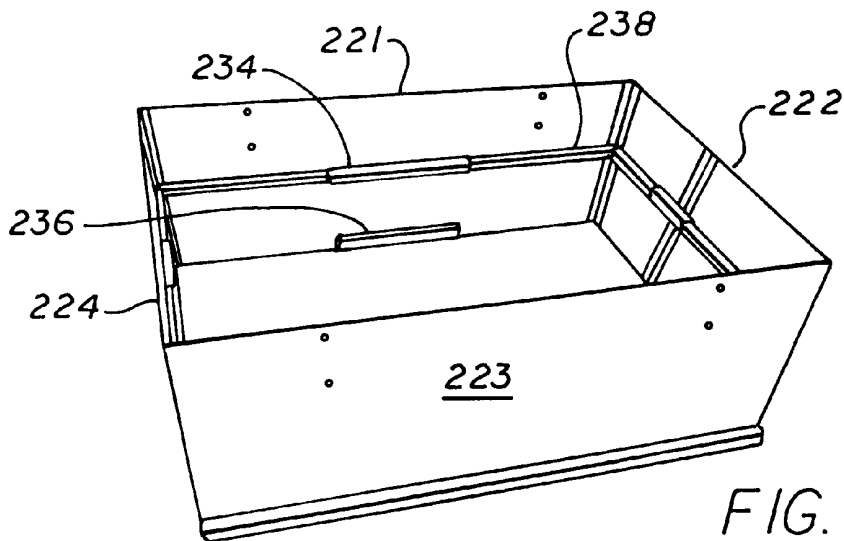
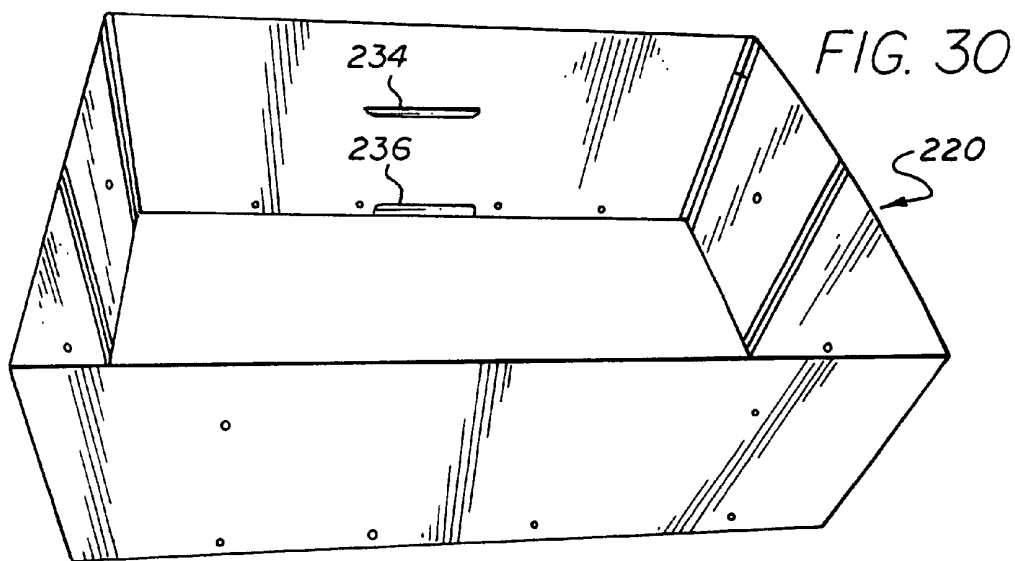
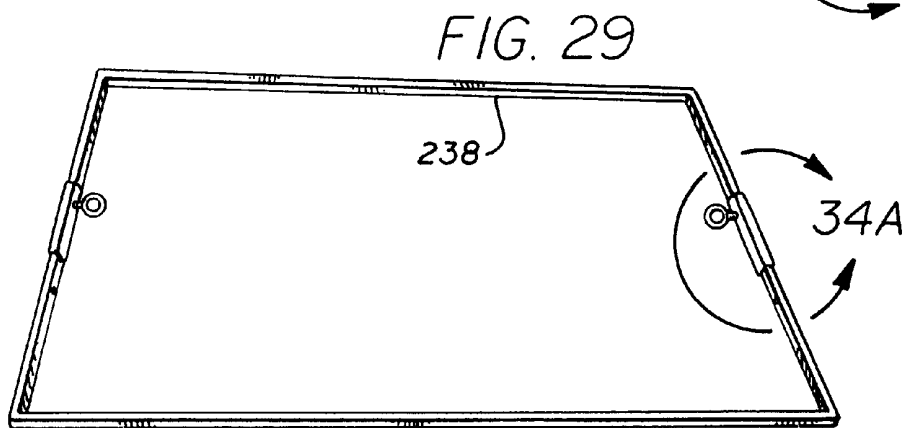
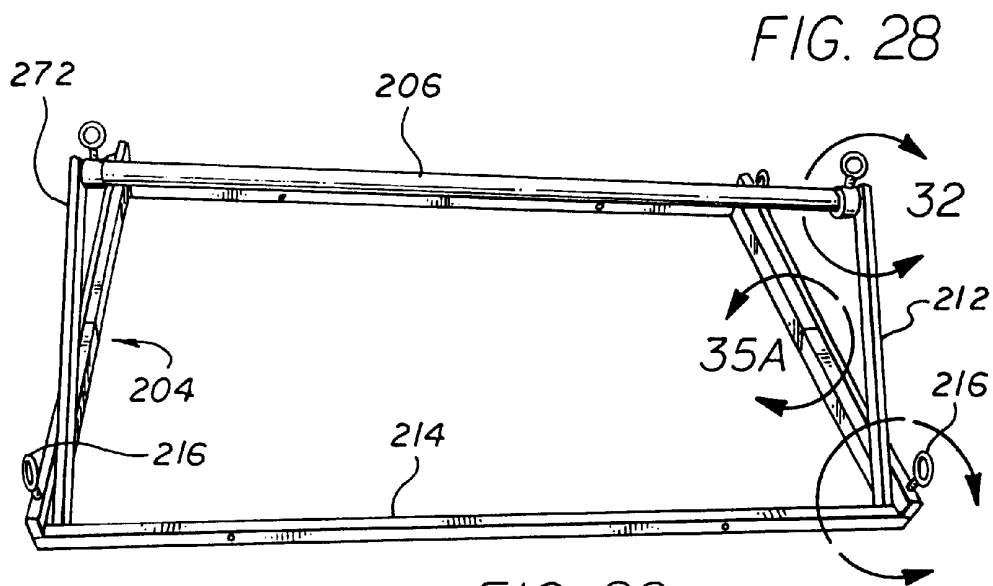

FIG. 25



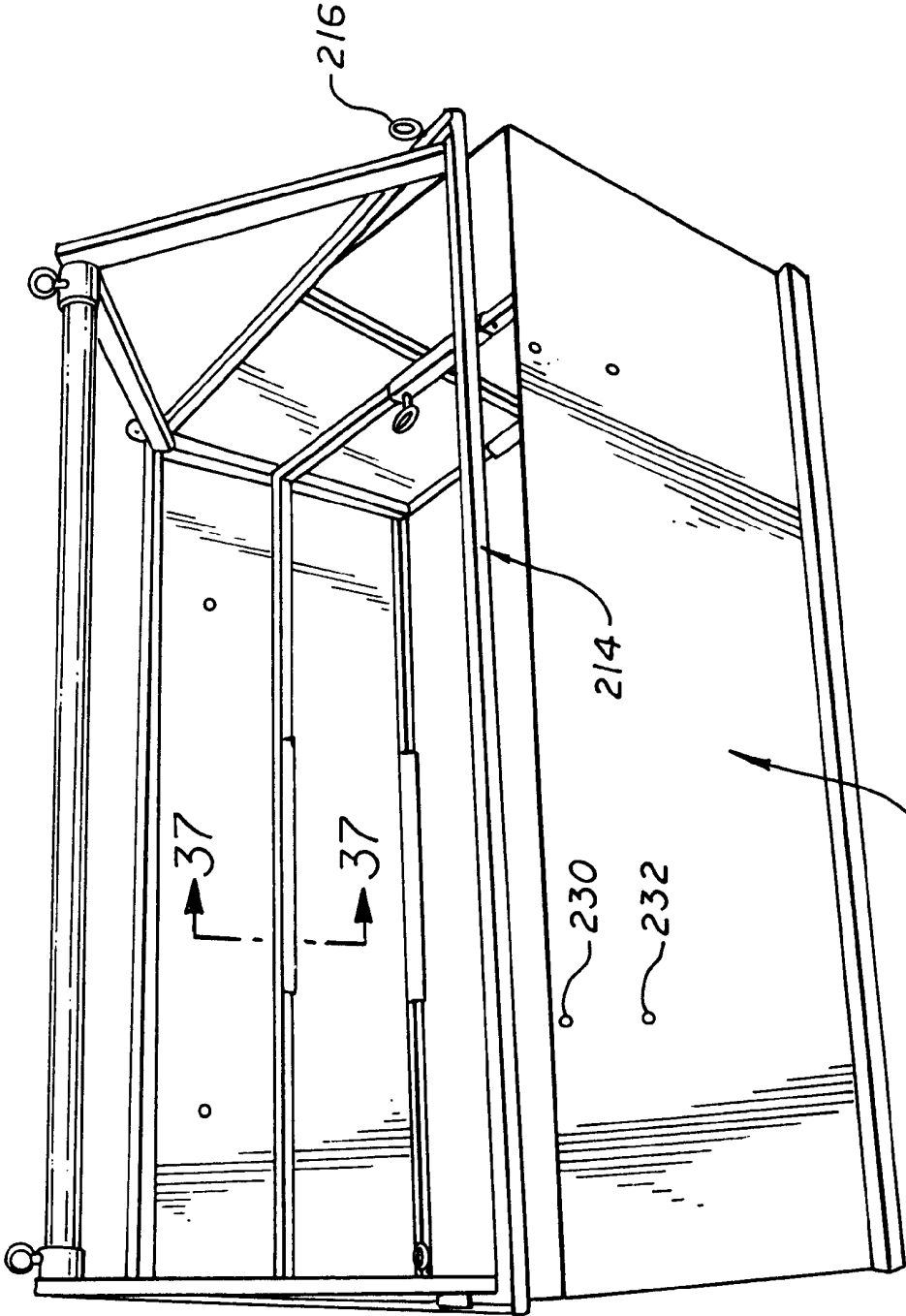

FIG. 31

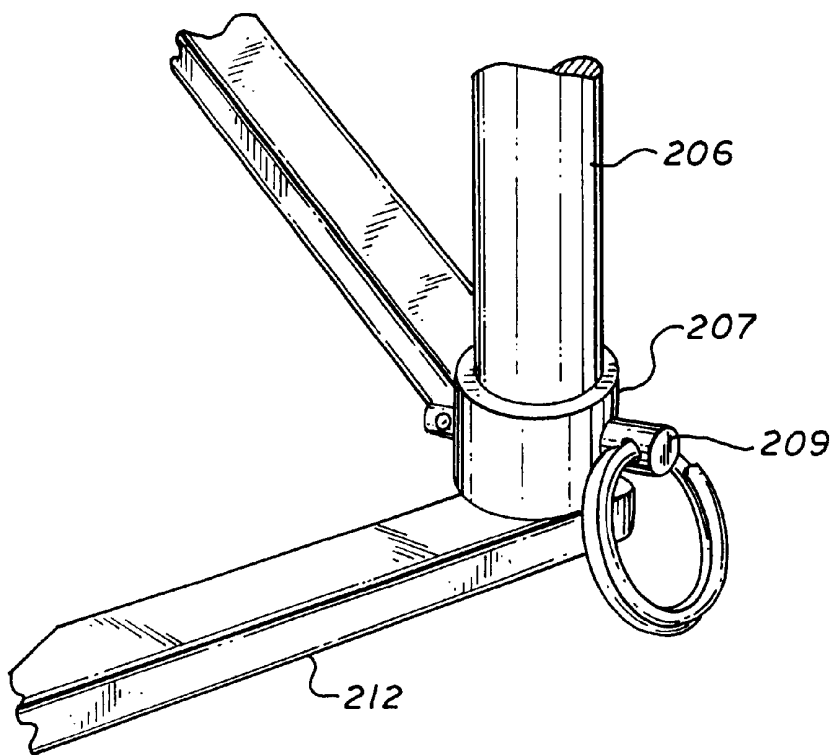

FIG. 32

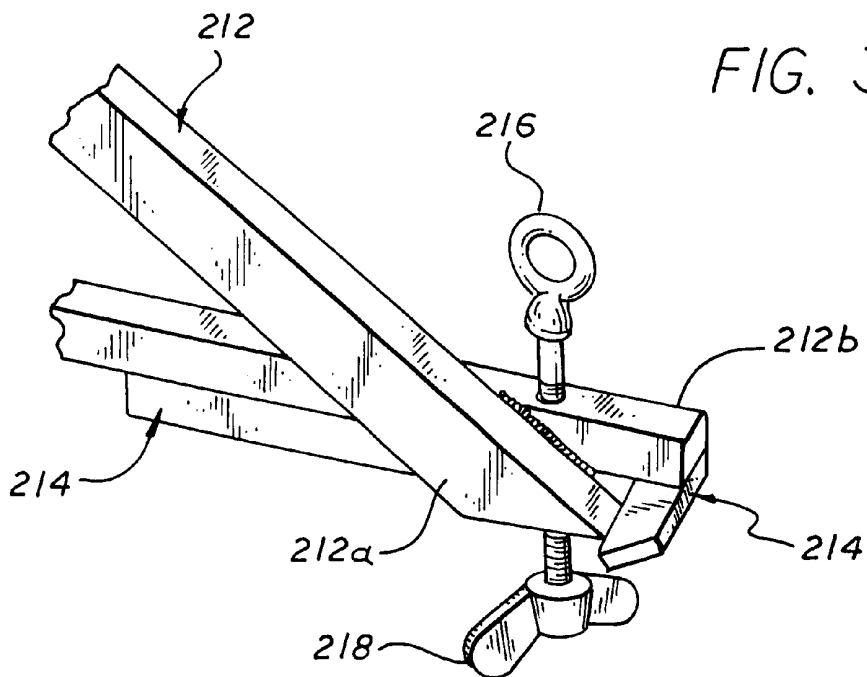

FIG. 33

FIG. 34

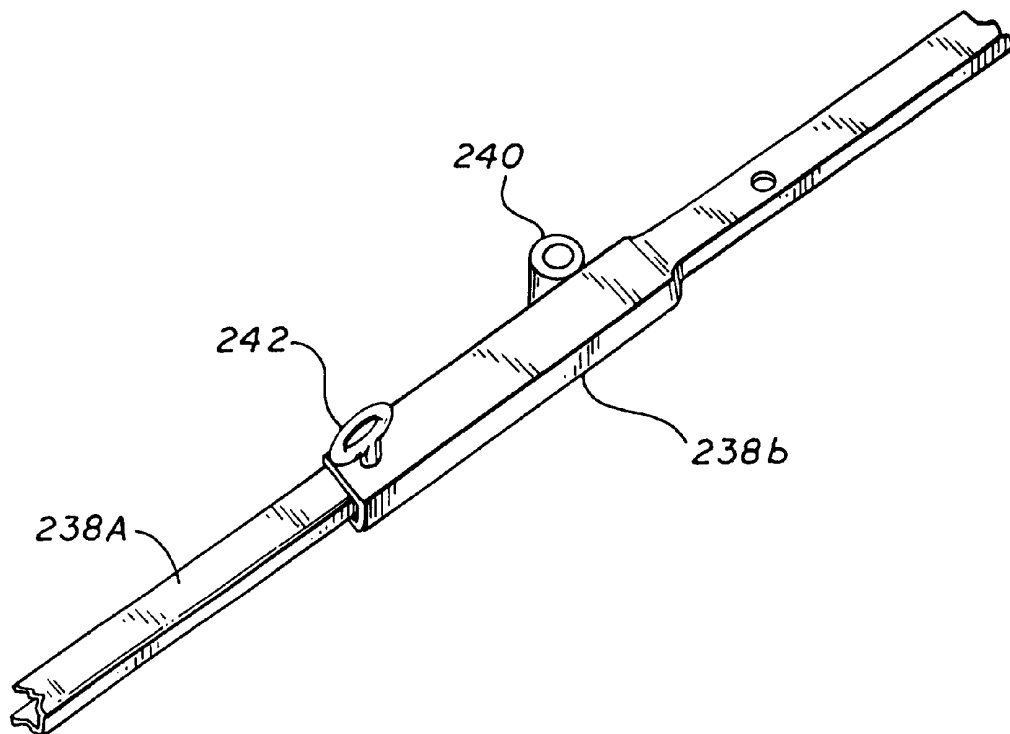
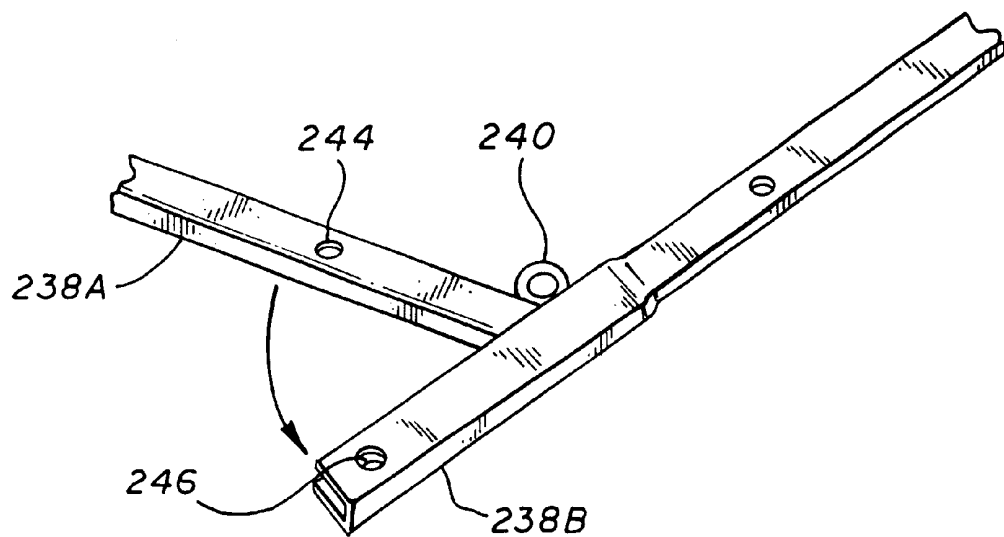

FIG. 34A

FIG. 35

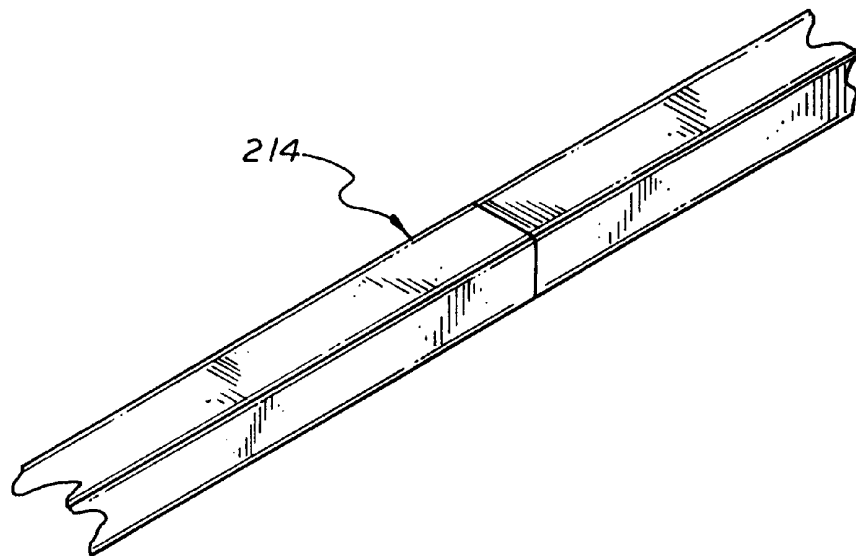
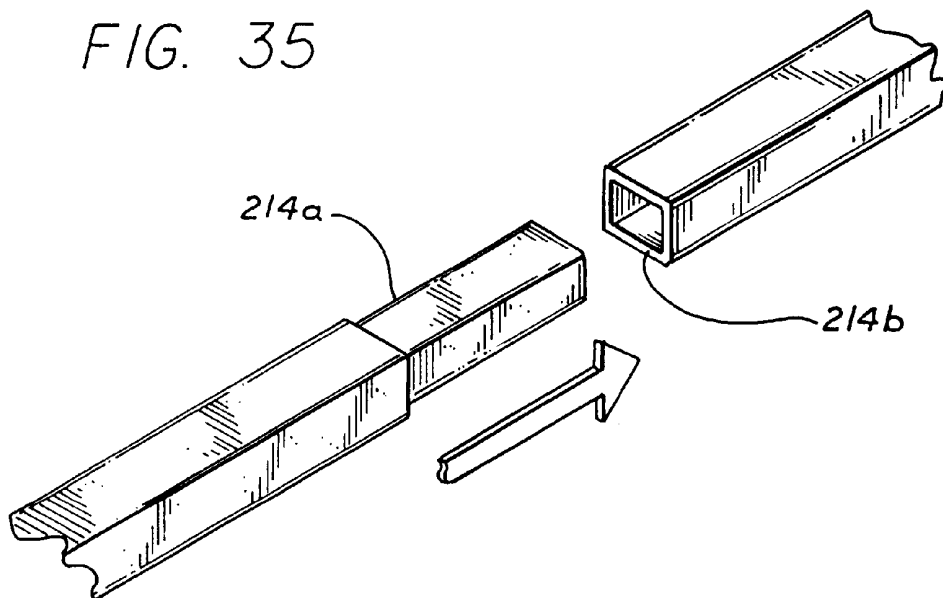

FIG. 35A

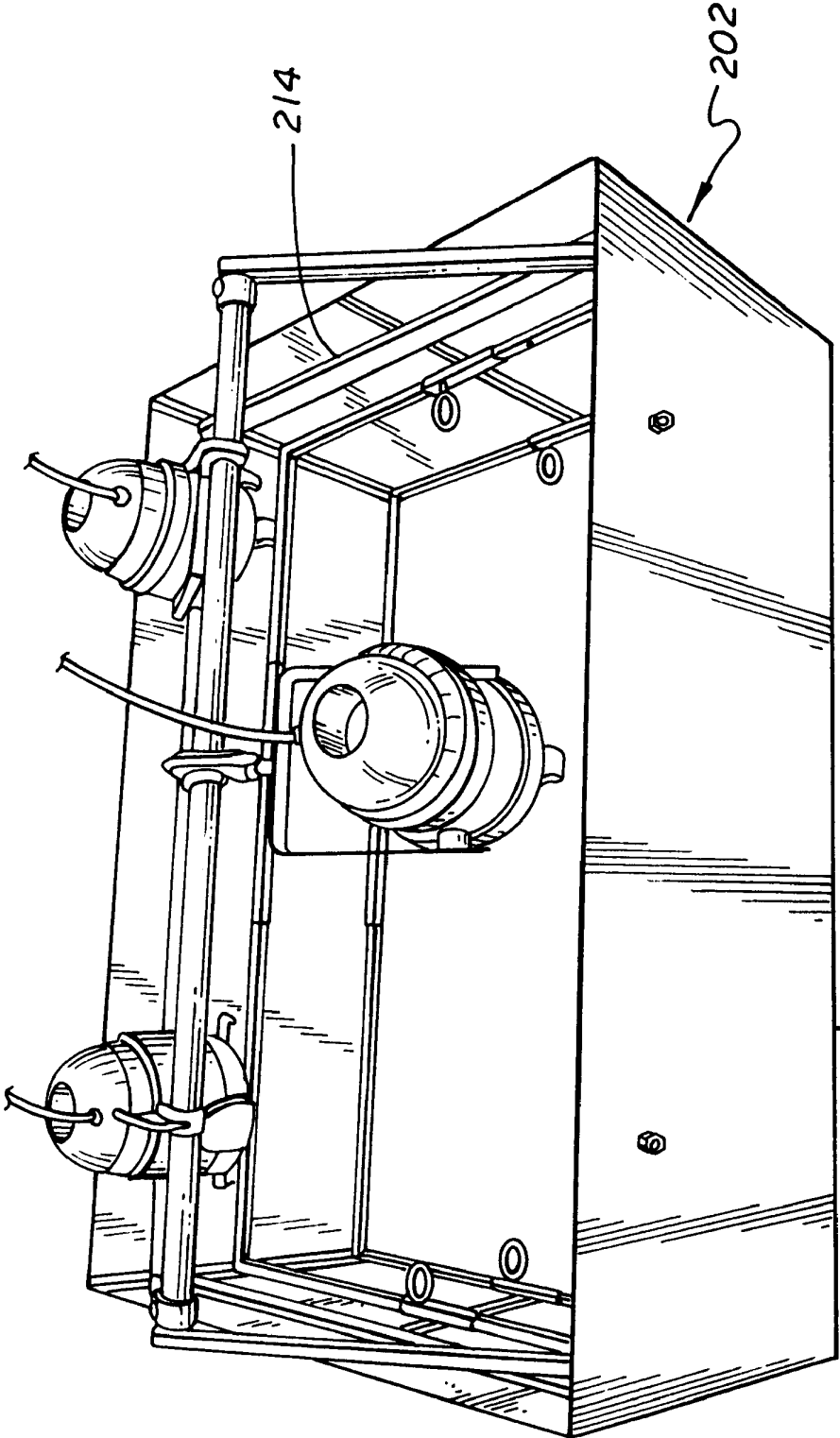

FIG. 36

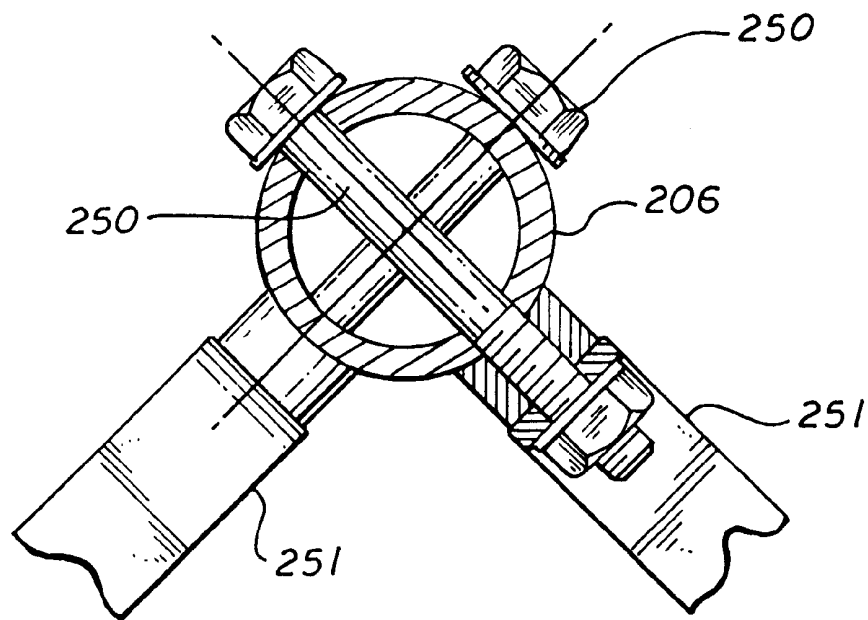

FIG. 39

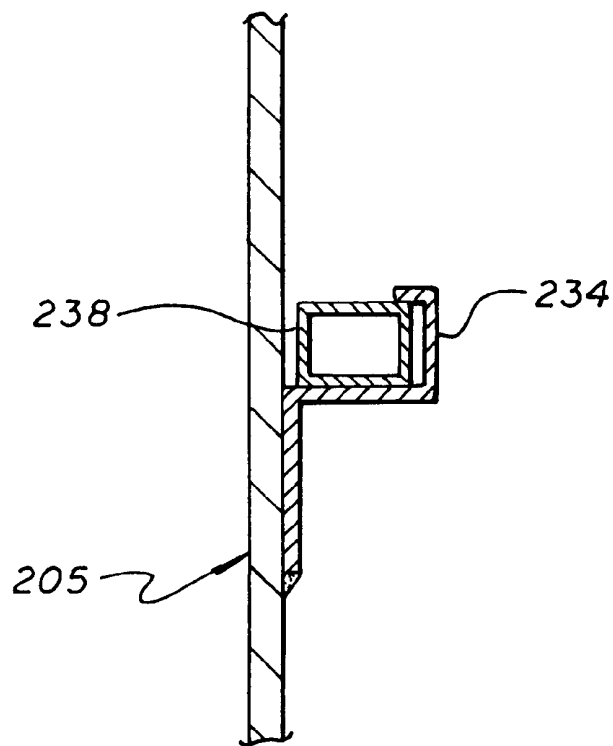

FIG. 37

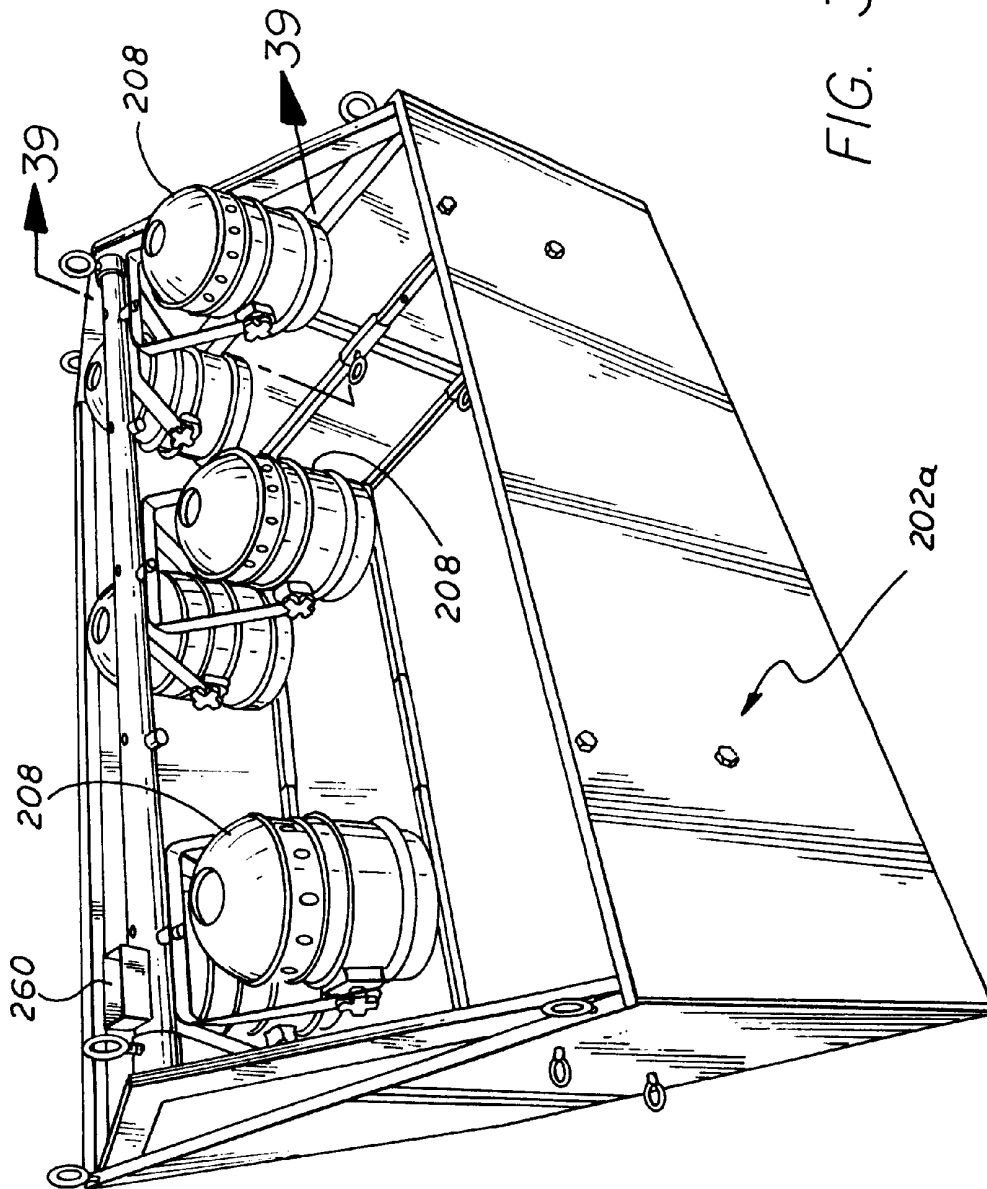

FIG. 38

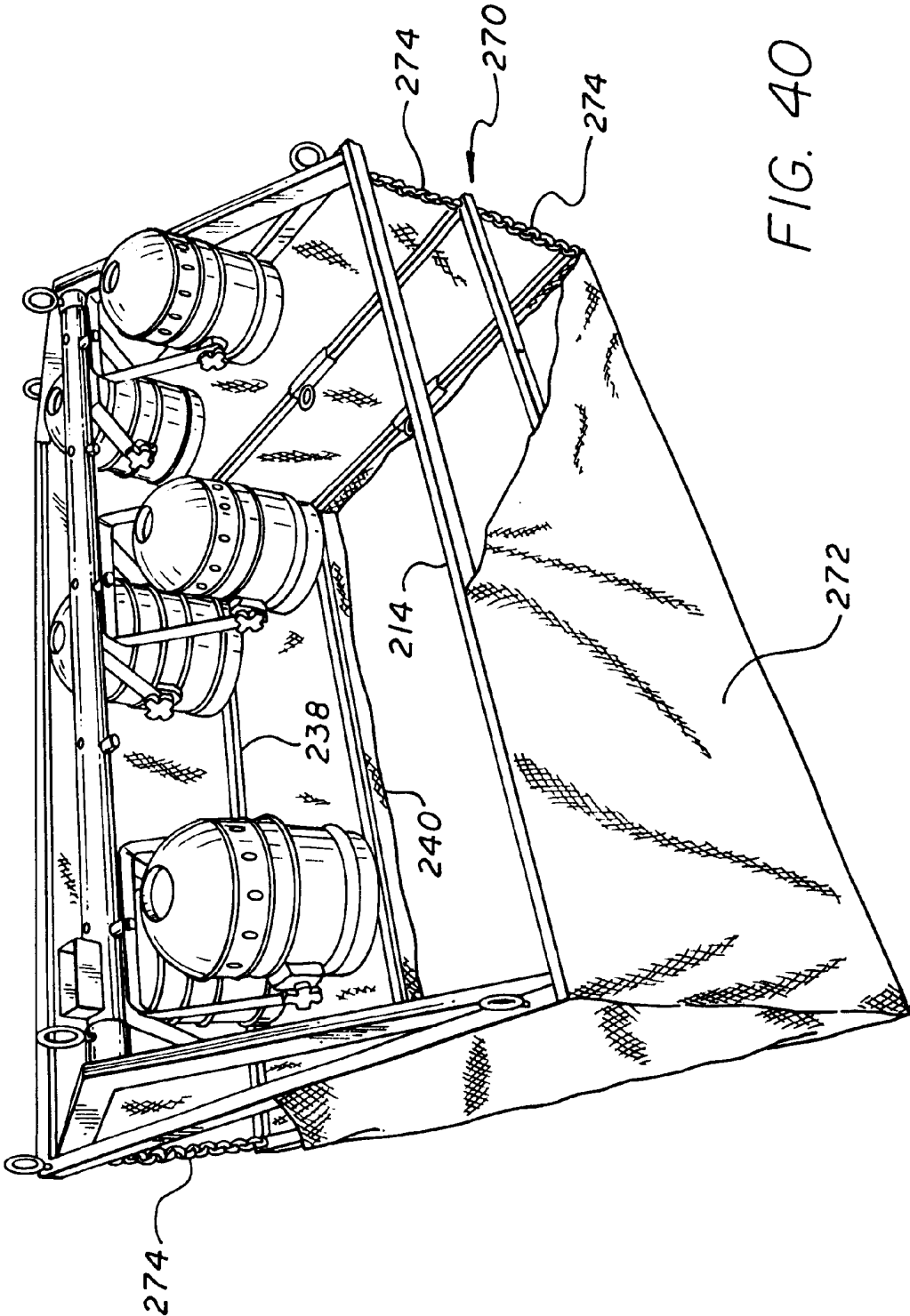
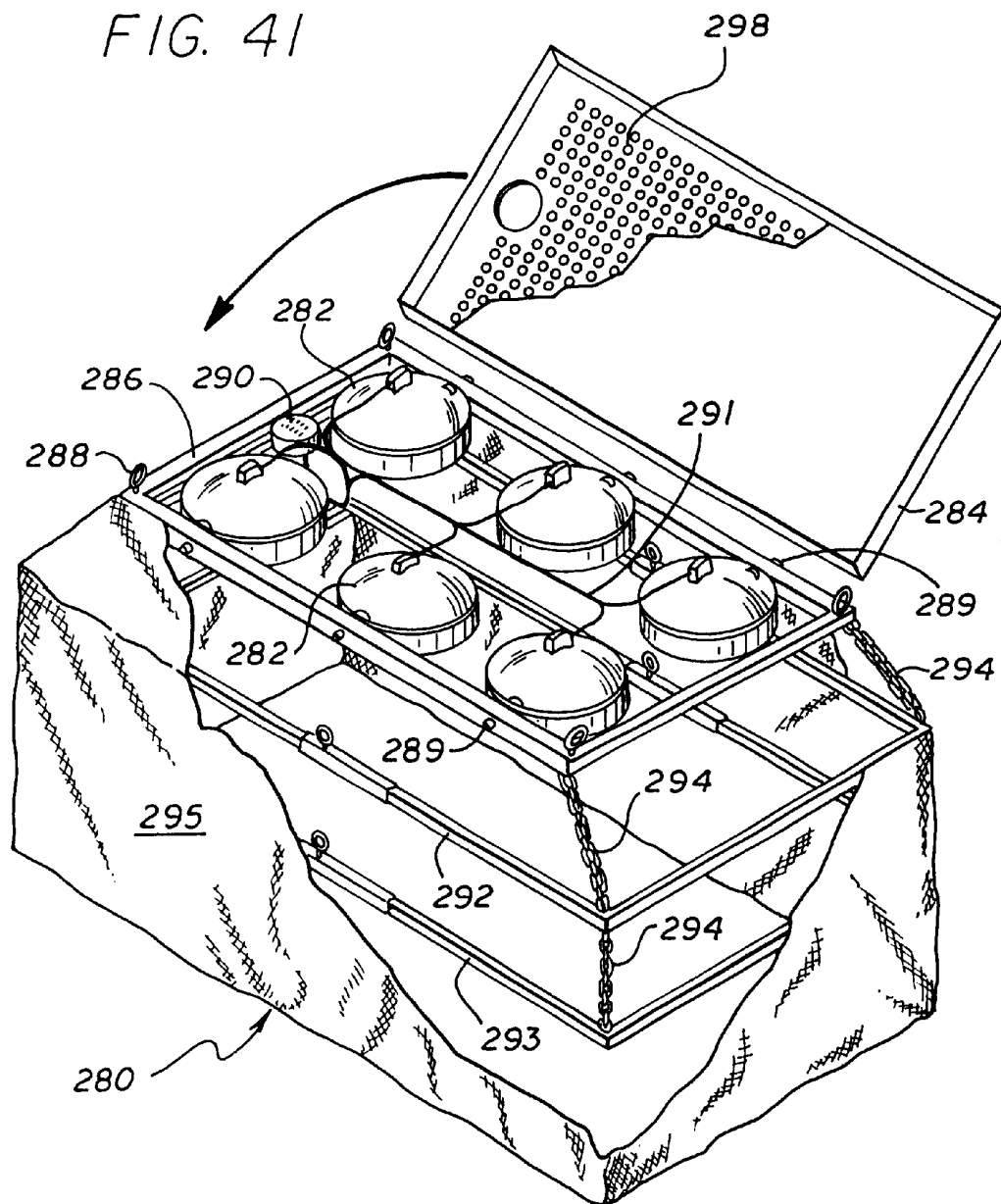

FIG. 41



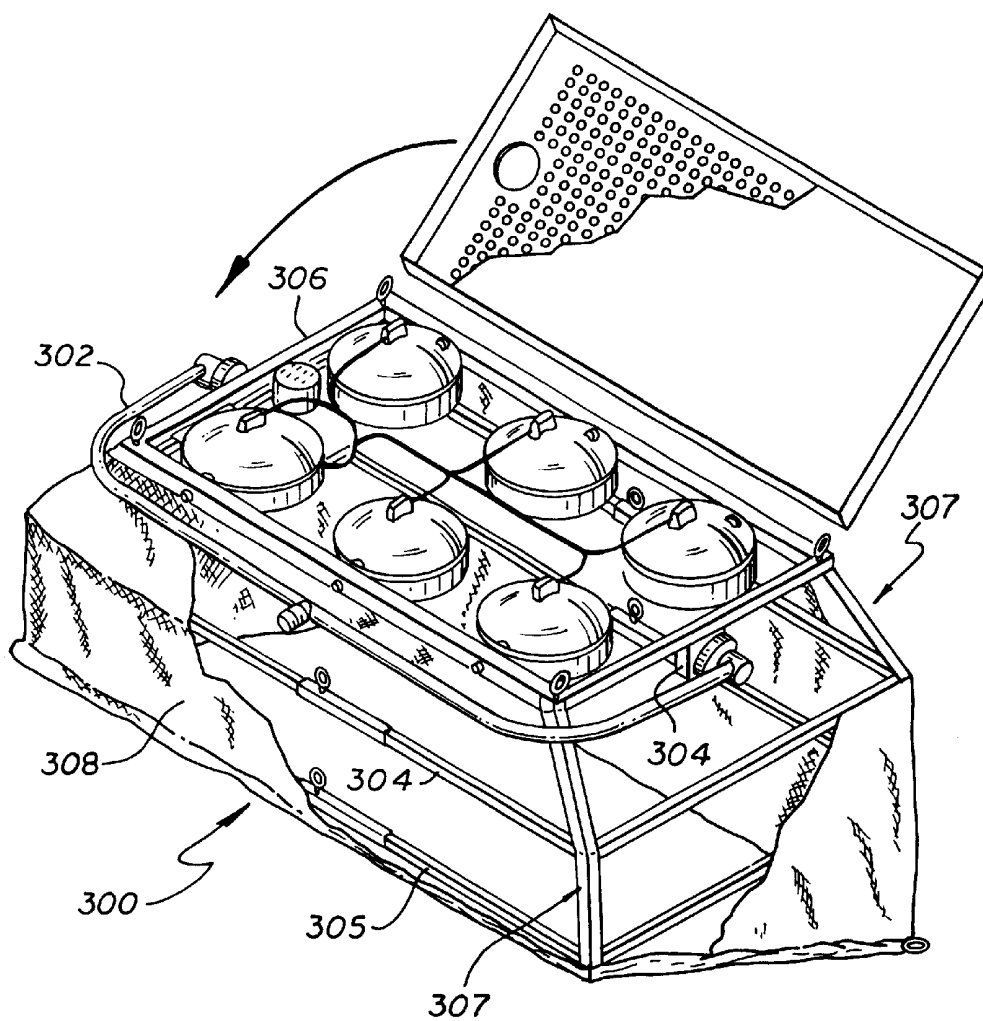

FIG. 42

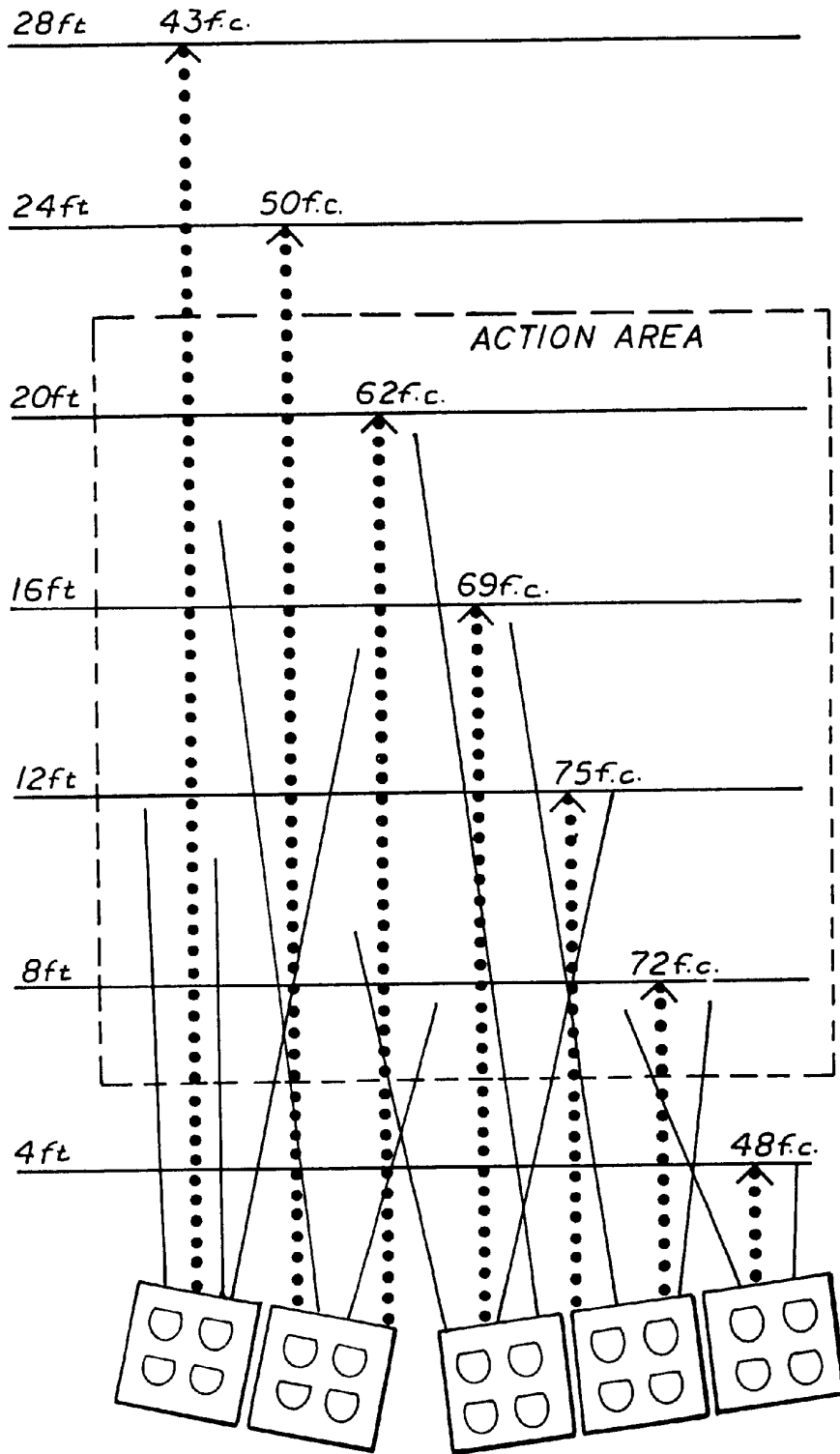

FIG. 43

FOLDABLE LIGHT DIFFUSION BOX WITH FRAME ASSEMBLY

CROSS-REFERENCE TO RELATED APPLICATIONS

This application is a continuation-in-part of U.S. patent application Ser. No. 09/642,315, filed Aug. 21, 2000 now U.S. Pat. No. 6,588,912, which is a continuation of U.S. patent application Ser. No. 09/146,063, filed Sep. 2, 1998, now U.S. Pat. No. 6,106,125.

BACKGROUND OF THE INVENTION

The present invention relates to a portable modular light diffusion box, and in particular such a box which includes light diffusion frame(s) and the capacity to contain multiple lights.

In the entertainment industry including motion pictures, television and theatrical arts, as well as in the photographic industry and other fields, it is necessary to light a set, stage or other area. Often, particularly for an indoor set in the motion picture and television industries, the key (primary) lighting is provided at the back corners of the set (opposite where the camera and audience, if any, will be) to avoid boom (sound equipment) shadows and a fill light from the front in accordance with a theory known as back cross key lighting.

While back cross key lighting is used in almost all sitcoms, there are some inherent drawbacks to the system. One problem is that the "key" or strongest light comes from the top/back (upstage) portion of the set, so there are invariably shadows thrown from the people and objects on the set onto each other. Also, in many cases there are shadows from a person's facial features that fall upon that person's face, such as nose shadows. The strong ("hard") light coming from the back also creates hot rims around people and is especially objectionable on bald or light-haired individuals. This hard light, which is traditionally used, can also create unwanted microphone boom shadows.

In studio photography, light diffusion gel frames have been used to soften lighting by diffusing the light. These frames have been typically individually mounted in front of or to a lighting instrument.

Conventional wisdom is that the lights are mounted on a stand, on a pipe, or on typical set scaffolding known as a green bed. As there are numerous lights on a set, and as providing a diffusion screen on each light is cumbersome, and as it is further cumbersome to change such screens and to align such lights to properly cooperate, the use of individually mounted diffusion devices is not practical or economical for some set lighting, especially sitcoms.

Examples of individually mounted diffusion gel supporting members are shown in U.S. Pat. No. 5,651,602 to Joseph N. Tawil, issued Jul. 29, 1997, and U.S. Pat. No. 4,446,506 to Raymond G. Larson issued May 1, 1984. These require special brackets or rings to mount to the lighting instrument, and are often dependent on the type of light.

A diffusion device has been known to be used with multiple lights, such as in U.S. Pat. No. 4,855,874 to Thomas A. Waltz issued Aug. 8, 1989. The Waltz patent discloses a light modifier which is inflatable and surrounds multiple lights attached to a stand or to other support rods which are not part of the inflatable device. The device itself which provides light diffusion must be entirely changed to change the light diffusion effect, and it has limited ability to control and direct light. It is therefore impractical to use for set lighting.

U.S. Pat. No. 5,128,838 to Muriel H. Brandess issued Jul. 7, 1992, discloses a photographic filter-holding apparatus that has a mechanism for holding a filter in front of a light. In one embodiment there are two lights, but each light has a separate filter, and it also requires a special mounting structure.

Even when diffusion is used, often expensive fresnel lights are used with it. These are focusable between "spot" and "flood" conditions, and provide a useful light source because you can change the pattern and intensity of the light when it is not heavily diffused, allowing for a tight "spot" of hot light, a wide flood of lesser intensity, or a selectable middle ground. It is interesting to note that when projected through heavy diffusion, this function is neutralized. However, fresnel lights have drawbacks. They are expensive, inefficient and heavy.

What is needed is a box which can diffuse and control light from multiple lights in such a way that the box and lights are stable, preferably avoid the need for expensive lighting instruments such as fresnel (focusable) lights, and provide soft, diffused light preferably from multiple instruments such as par cans ("pars"), to enable the use of front projected lighting as the key or primary lighting for a stage or set.

What is also needed is a device that can project soft key light in a controllable way deep into the set evenly from front to back and side to side while having a compact profile to allow for cameras underneath and viewers behind. The light would be parallel to and under the microphone booms thus eliminating boom shadows. The light would also come from a similar angle as the cameras eliminating or "burying" shadows behind the objects themselves.

Certain lights have been made for overhead lighting, i.e., above a set or other item needing light. However, these do not provide an efficient soft projected and consistent light. For example, one configuration known as the "chicken coop" has six 1000-watt bulbs shaped much like household bulbs. Light is unevenly pushed through the lamps themselves and bounced off the light shell, resulting in a very mixed source with limited projection. Even if a diffusion screen is used, the light is inconsistent and the bulbs cannot be individually controlled.

Sometimes, a long cylindrical fabric sheath with a roughly 30-inch diameter opening is placed around some open globes in a wheel type configuration known as the space light. The sides of the sheath can be blackened. The problem with this light as an overhead light is that it uses a lot of energy for very little output. Much of the light is absorbed in the black sheaths and not output from the opening at the bottom of the sheath. The source, being just globes, is not internally or externally focused to project well through the exit port as described.

Light diffusion elements have been constructed of cardboard or other consumables in a jury-rigged fashion for a long time. There also is a company known as Chimera which markets cone-shaped soft tent-like members for attachment in front of a lighting source, typically a single fresnel light. However, none of the extensive art combines a box with interchangeable diffusion frames and standard light mounting rods facilitating the use of multiple par cans, e.g., four or more, to create a deeply projected but soft light that is consistent from near to far. Moreover, none put all of these elements together with built-in lights in a way that enables use of inexpensive light-weight lights with high output to obtain a soft projected light.

What is needed is a high-output, projected soft light from a modular system using multiple lights. What is also needed

is such a system that is provided in a lightweight, foldable structure which readily mounts to standard mounting equipment such as stands, scaffolding or other existing support structure. What is also needed is a way to obtain soft projected light from inexpensive, non-focusable lights. What is needed is one device that solves many needs.

SUMMARY OF THE INVENTION

In each embodiment, the invention provides a light box which is preferably lightweight, foldable, modular and provides for soft projected light regardless of the lighting elements used. The invention, thought not limited to the use of nonfocusable lights, makes the use of inexpensive par lamps practical. Such lamps have an internal parabolic reflector which creates an extremely parallel beam of light. This "punchy" light has been found to be ideal to project through diffusion mediums to soften the resultant light, but to retain much of the deep throw inherent in the lamp. It has also been found that when combining par lamps of various intensities (i.e., wide and medium beams at specific distances through diffusion frames), it is possible to create a light that is more consistent from upstage to downstage than a point source or more traditional lighting instruments. The foldable modular light diffusion box in all its forms uses this principle as its cornerstone and constructs devices useful for the motion picture and television industries as well as other uses. Although par lamps are existing technology and diffusing light through frames is not novel, both the concept and forms of the foldable modular light diffusion box create and contain light in a new way and of a quality, portability and consistency previously unavailable.

The invention further provides a substantially consistent light intensity in spite of the inverse square law. Light intensity from a point source drops off according to the inverse square law, i.e., intensity (i) at any distance (radius) (r) or from a point source of intensity (I) is given by the following equation: $i=I \times (1/r^2)$. However, in the invention, as noted above, consistency is maintained.

In one embodiment, the invention provides a modular light diffusion box which preferably is adapted to hold multiple lights. The box has a housing for channeling and controlling the light, the housing having two sides, a top and a bottom formed so as to be lightweight yet rigid or substantially rigid. The housing also has a channel or channels for supporting a diffusion frame or frames, or filters. In a preferred embodiment, the housing supports a bar, such as a standard 1½" or 1 5/8" pipe (e.g., Speed Rail™) or other cross-member on which multiple lights may be mounted. In another preferred embodiment, the box is foldable and portable. It is also preferable that the box have an angle at its front end for directing light towards a set or stage when the box is elevated with respect thereto.

According to a modified embodiment of the invention, there is provided a foldable, modular light diffusion box containing an element for mounting multiple lights, and preferably containing multiple lights mounted therein. More preferably, these lights are high intensity but inexpensive, lightweight, and nonfocusable lights such as pars or par cans.

In a second embodiment, the invention provides a modular light diffusion box which has multiple lights disposed therein. Preferably, the lights are inexpensive, nonfocusable lights such as pars. The box has a housing or shell having four sides connected together for folding flat. The housing has an open front and an open back. One of the sides has an access door for opening and closing to selectively insert and

replace diffusion screens or filters. A C-shaped yoke rotatably connects to two sides of the shell on the outside. The yoke has a standard pin for mounting to a stand or other standard female receptor. A rectangular reinforcing skeleton or frame mounts inside the shell and the lights are fixed to a standard pipe or rod mounted inside the rectangular frame.

In a third embodiment, the box is similar to the previous embodiment and has four lights therein. The front of the box has an angular face. The box is mountable to a green bed, scaffolding or otherwise supportable in the air by hanging it, rather than having a yoke. The box is constructed such that it may be placed adjacent other boxes to provide for a larger projected light. In this embodiment, the rectangular frame has two triangular frame elements connected to it, and the triangular elements support a standard rod for mounting the lights.

In a fourth embodiment, the box is rectangular and is hinged at the center of its short sides to collapse together. The box is adapted to be hung from a ceiling or other structure directly above the area to be lit. In a fifth version of this box, the shell may be soft, e.g., made of fabric and attached to, so as to hang from, the rectangular frame. The diffusion or gel frames are also attached to the rectangular frame at their corners by a chain or other flexible or collapsible attachment. The lights connect to a Socopex™ connector or the equivalent. Yet another version of such a flexible, collapsible box has a rear cover which is perforated to provide for protection for the lights, which are built-in.

Still another version has built-in lights and a cover, a yoke mounted to the rectangle, and rigid members to hold the fabric instead of chain.

BRIEF DESCRIPTION OF THE DRAWINGS

FIG. 1 is a schematic perspective view of five (5) light boxes for front projection illumination of a set in accordance with the invention;

FIG. 2 is an exploded perspective view of a light box according to the invention;

FIG. 3 is a side view (rotated 90° clockwise with respect to FIG. 2) showing a top and left-side subassembly and a bottom and right-side subassembly of the box of FIG. 2 in a folded position in accordance with an aspect of the invention;

FIG. 4 is a perspective view (rotated 90° clockwise with respect to FIG. 2) showing a bottom of the box of FIG. 2 with a bottom door open and a diffusion screen being slid into the box in accordance with another aspect of the invention;

FIG. 5 is a side view of the box according to the invention showing an angle at which the front edges of the left and right side panels are cut in accordance with a further aspect of the invention;

FIG. 6 is a schematic diagram of a set with front projected lighting provided from a plurality of boxes in accordance with the invention; and

FIG. 7 is an enlarged view of a portion of FIG. 2 inside circle 7;

FIG. 8 is a schematic diagram showing par lights for illustrating and explaining a lighting theory of the invention;

FIG. 9 is a partly exploded and front perspective view of a lighting box according to a second embodiment of the invention;

FIG. 10 is a perspective view of a shell of the box of FIG. 9 without a rectangular frame and other parts of the box attached thereto, so that the shell is ready to fold;

5

FIG. 11 is a perspective view of the shell of FIG. 10 in a partially folded state;

FIG. 12 is a perspective view of the shell of FIG. 10 in a folded state;

FIG. 13 is a perspective view of the box of FIG. 9 mounted to an overhead mounting arm and tilted at an angle facing partly downward;

FIG. 14 is a perspective view of the box of FIG. 9 mounted to a stand and tilted at an angle facing partly downward;

FIG. 15 is a rear perspective view of a light box according to a third embodiment of the invention;

FIG. 16 is a view of the shell of the box of FIG. 15 without any other structure;

FIG. 17 is a view of the skin in a mostly folded state;

FIG. 18 is a perspective view of a rectangular frame element in the box of FIG. 15;

FIG. 19 is a perspective view of a frame assembly including the rectangular frame element connected to two triangular frame elements, which in turn hold a bar or rod for mounting lights in the box of FIG. 15;

FIG. 20 is a rear perspective view of the box of FIG. 15 showing only the shell and the frame assembly;

FIG. 21 is an enlarged view of part of the frame assembly taken along the circular line 21 of FIG. 19 showing how the bar and triangular frame elements connect;

FIG. 22 is an enlarged view of a corner of the box taken along the circular line 22 of FIG. 23;

FIG. 23 is a front perspective view of multiple boxes of FIG. 15 mounted to scaffolding or a green bed similar to FIG. 1;

FIG. 24 is a rear perspective view of a lighting box for mounting above a set, stage or other area to be lit according to a fourth embodiment of the invention;

FIG. 25 is a perspective view of a shell of the box of FIG. 24;

FIG. 26 is a perspective view of the shell in a partially folded state;

FIG. 27 is a perspective view of the shell in a folded state;

FIG. 28 is a perspective view of a frame assembly in the embodiment of FIG. 24;

FIG. 29 is a perspective view of a gel frame for use in the box according to FIG. 24;

FIG. 30 is a perspective view of the shell of the box of FIG. 24;

FIG. 31 is a rear perspective view of the box of FIG. 24 for purposes of explaining how a gel frame is held therein;

FIG. 32 is an enlarged view taken along circle 32 of the frame assembly of FIG. 28;

FIG. 33 is an enlarged view taken along circle 33 of the frame assembly of FIG. 28;

FIG. 34 is a perspective view of a hinge connection in a partially folded state in the diffusion frame of FIG. 29;

FIG. 34A is a perspective view of the hinge connection in a fully assembled state in the diffusion frame of FIG. 29 taken along a circle 34A;

FIG. 35 is a disassembled view of a portion of a rectangular frame element in the frame assembly of FIG. 28;

FIG. 35A is an assembled view of the same portion of the rectangular frame element taken along circle 35A of FIG. 28;

FIG. 36 is a rear perspective view of a box similar to that of FIG. 24 but with the frame assembly mounted further into the frame assembly shown in FIG. 24;

6

FIG. 37 is an enlarged sectional view taken along a line 37—37 of FIG. 31 to show how a diffusion frame is held in the box of FIG. 24;

FIG. 38 is a rear perspective view of a lighting box similar to that of FIG. 24 but having lights fixed to a rod for mounting lights, and a connector for commonly wiring all of the lights;

FIG. 39 is an enlarged sectional view taken along a line 39—39 of FIG. 38 to show how lights are connected to a rod for mounting lights;

FIG. 40 is a rear perspective view of a lighting box according to a fifth embodiment of the invention where the shell is soft;

FIG. 41 is a rear perspective view of a lighting box according to a sixth embodiment of the invention where the shell is soft and the box has a rear cover with lights held in collars with retaining rings rather than cans;

FIG. 42 is a rear perspective view of a lighting box similar to FIG. 41 but for mounting on a stand or mounting arm; and

FIG. 43 is a schematic diagram for purposes of explaining additional lighting theories according to the invention.

DETAILED DESCRIPTION OF THE PREFERRED EMBODIMENT(S)

In FIG. 2, a box 1 according to one embodiment of the invention is shown. It has a housing with four sides, namely a left side 4, a right side 6, a top 8 and a bottom 10, which are shown planar. The back is preferably open and the box preferably has a light mounting structure such as a cross-member, holder or bar 14. Bar 14 is preferably formed by speed rail, a standard rod well known in the motion picture and television industry for mounting lights such as pars. The bar 14 may be any kind of cross-member or other structure suitable to readily mount multiple lights. At the front of the housing there are two diffusion holding elements, filter holding elements, screens or frames 16, 18, which each hold diffusion elements or filters. In use only one diffusion screen or filter need be used. Part of the screen or screens may be made opaque for further control of the light emanating from the box. The phrase diffusion element will be used herein to mean diffusion frame, screen or other structure used to diffuse or soften light from the stage lights.

The bar 14 is mounted to the left and right sides of the housing by means of members or V-brackets 20, 22, having cups 24, 26, respectively, which each receive the ends of the bar. Set screws 28 and 30 are used to fix the ends of the bar in the cups.

In the disclosed embodiment, each side, top or bottom of the housing consists of a skeletal frame with frame members and a panel, preferably opaque, and the sides are hinged together. With continued reference to FIGS. 2, 3 and 4, side 6 has frame members 36, 38, 40, 42 and 44 and an opaque (right side) panel 46 to which the frame members are bolted, riveted, soldered or otherwise connected. The left side 4 is constructed using a mirror image of frame members to which a panel 48 (an opaque, left side panel) is fastened in like manner. On the right side panel 46, and in like mirror image on the left side panel 48, there are two channel members 40a, 42a for receiving the diffusion elements 16, 18. The diffusion elements are constructed preferably in a manner similar to screen windows. If only one diffusion element is used, it is preferable to use the forwardmost element 16. The top 8 also has a panel 50 and frame members around the edges, including frame members 47, 49, 51. The bottom 10 has two panels 60, 62, the larger panel

having frame members **52**, **54**, **56** and **58** around its edges and the smaller panel **62** having frame members **53**, **55**, **57** and **59** around its edges. The smaller panel and its frame members form a door **10a**.

The various frame members may be rectangular tubing, and the frame members, panels and other components are preferably of a lightweight but strong material such as aluminum, and the channel members may be C-shaped and preferably constructed of a lightweight rigid material such as aluminum as well. The sides, top and bottom may be formed of any rigid or semi-rigid material sufficient to support the cross-member **14** and a mechanism for mounting the cross-member **14**.

So that the box is easy to transport and store, the sides, top and bottom are preferably formed so as to be foldable in two units, as shown in FIG. 3. The left side of FIG. 3 shows left side **4** and top **8** which are preferably permanently hinged together for rotation and folding about axis A. The right side of FIG. 3 shows bottom **10** and right side **6** which are permanently hinged together for folding about axis B. The permanent hinged connections are shown by hinges **65** in FIG. 2 which connect the bottom frame member **52** to the right side frame member **38**, and like hinges (not shown) connect a frame member of the left side **4** and top **8**. The two subassemblies, i.e., the top **8** and right side **6** and the bottom **10** and left side **4**, connect together by means of two sets of knockout hinges. These include half hinge members **63** mounted to frame member **36** of the right side **6** which mate with half hinge members **63a** (FIG. 3), which then receive a knockout (hinge) pin. Similar half hinges **67** and **67a** are mounted on the bottom frame member **56** and a frame member (not shown) of left side **4**. With this structure, the two subassemblies may be readily connected and disconnected by inserting or removing hinge pins.

The door **10a** of the bottom enables the diffusion elements **16**, **18** to be readily removed and replaced when the box is assembled, even when it is in place for lighting a set or stage. Hinges **80** (FIG. 3) on the external side of bottom **10** connect panel **60** and panel **62**, which is smaller than panel **60**, and thus enable the door to rotate open and closed. As best shown in FIG. 4, two angle members **82** bolted at one end to the sides **4**, **6**, are rotatable between the positions shown in FIG. 1 to hold the door closed and the position shown in FIG. 4 to open the door.

In one embodiment of the invention, the housing and diffusion element(s) may be used without the V-brackets and bar, and may be mounted to scaffolding or otherwise positioned in front of multiple stage-type lights. In the preferred embodiment, multiple stage-type lights **75**, **76**, **77** and **78** may be readily clamped onto the bar **14** supported by the housing. Where the bar is a rod such as speed rail™ or the like, typical stage lights have C-clamps **90** readily connectable to such rod or speed rail™. Therefore, regardless of the stage-type light that is used, it may be quickly mounted and unmounted from the bar **14**. Accordingly, no special mounting structure is necessary, although any suitable mounting structure will do.

In operation, the box may be assembled as follows:

The two sub-assemblies of FIG. 3 may be rotated to be open at 90°. The hinge halves **63**, **63a** and **67**, **67a** are then positioned to mate, and the hinge pins are inserted. The housing may then be rotated onto its bottom panel and the V-brackets **20**, **22** may be bolted to the frame members of the left and right side using wing nuts **92** and bolts **94** (shown in detail in FIG. 7), after inserting the speed rail in the cups **24**, **26** and tightening the set screws **28**, **30**.

Alternatively, the V-brackets may be affixed to the side members before the side members, top and bottom subassemblies are connected. One side of the speed rail would then be inserted into one cup and the set screws tightened, and the other side would then be inserted into the remaining cup upon connecting the side, top, bottom and other side.

Once the housing, V-brackets and bar are connected, the stage lights are mounted using the C-clamps and the diffusion elements are slid into place. The door **10a** is rotated closed and the angle brackets **82** are rotated downward (in FIG. 2) to hold the door closed (as shown in FIG. 1). The box may be disassembled in reverse order.

Preferably, the back of the box is open which allows for venting of the lights, as well as easily mounting them, disconnecting them, electrical line access, and positioning of the lights.

In accordance with another aspect of the invention, several boxes may be used adjacent one another or otherwise positioned to cooperate to light a set. These boxes may be suspended, such as from scaffolding, as shown in FIG. 1. In the television and movie industry, existing scaffolding in indoor stages is known as a green bed. A simple means to suspend the box or boxes from the green bed is to provide eye bolts **81** fixed to the frame members of the top **8** and use chain or rope **83** connected to the eye bolts and the scaffolding as shown in FIG. 1. As also shown in FIG. 1, three boxes **1** are adjacent one another on the viewer's left side of FIG. 1 and two boxes **1** are adjacent one another on the right side of FIG. 1. The three boxes together would typically provide greater light, given use of the same lights in each box, and thus be known as key lighting for a set or stage and the two box group would provide fill light.

With reference to FIG. 5, the angular front edges of the left and right side members will be explained. The angle provides a way to channel and direct light when the boxes are horizontally mounted, such as shown in FIG. 1, with the top flush or parallel to the green bed or the like. The angle also allows light to project to the upstage portion of the set and the downstage portion, even though the boxes are mounted in the air and close to the set. The angle may be selected depending upon the geometry of where the boxes are mounted in relation to the set, as well as any other factors well known in the art. For example, the top may have a depth dimension D of four feet and the bottom may have a depth dimension C of three feet, thus providing front edge E with an angle "tilted downward." Preferably, the distance from the top of the box to the bottom would also be four feet. The angular orientation of diffusion element **16** also provides a greater surface area with which to diffuse the light.

The boxes can be constructed larger, or smaller, with any appropriately desired dimension, but it is advantageous to construct them with a four-foot square length and width cross-section. This size readily accommodates four lights, the two lights on top and the two lights on the bottom. Alternatively, the box could be eight feet wide by four feet tall which would accommodate eight lights for standard pars. More lights can be fit into a box than is shown in the drawings, to increase the strength depending on the use. In addition, one may put lights at three or more relative heights or put more than two across.

By use of higher powered lights on top, upstage lighting can be comparable to downstage lighting, and by use of boxes placed side to side, lighting at one side of the set can be comparable to lighting at the other side.

The diagram of FIG. 6 shows how boxes according to the invention are used to provide for front-projected light to a

set. In a sitcom-type set, it has been conventional to light the actors **1A** and **1B** from the back typically by expensive, high-powered fresnel lights. The back (upstage) of the set **86** is defined with respect to the location of the camera **88** which is at the front (downstage). When a sitcom or the like is filmed, typically there is also an audience **84** located downstage. The key lights **180** and fill lights **182**, when constructed in accordance with the invention, may be provided at the front of the set. Undesirable shadows from objects, actors and boom sound equipment, which normally extends from the front from above the green bed, are avoided because of the diffused light emanating from the boxes rather than multiple high-powered beams from multiple lights located below and parallel to the booms. Moreover, the boxes take a diffusion element and apply it to multiple lights in a way that is quickly and easily controlled to light the entire set evenly. When the lights on top of the bar are higher powered than the lights below the bar, the upper lights illuminate the back of the set as well as the lower lights illuminate the front. The system thus may use inexpensive stage lights, e.g., pars, rather than expensive lights, e.g., fresnels, provide a higher level of light with significantly fewer lighting instruments, and achieve greater depth of field. For example, in a three box key light, one may use six 1000-watt pars (medium) for the upper lights and six 1000-watt pars (wide) for the lower lights and achieve a 4.6 @250 ASA on the downstage portion of the set and a 4.3 upstage, allowing for use of slower film or a deeper depth of field, or a combination thereof.

A lighting theory according to the invention and its beneficial results is explained and illustrated with reference to FIGS. **8** and **43**. A series of five lighting boxes **100** are each equipped with two medium 1000-watt par lights **102** and two wide 1000-watt par lights **104** below them. As shown in FIG. **43**, diffusion screens **106** and **108** were used, and light intensity was measured at eye level at locations A, B and C, ten feet, fifteen feet, and twenty feet, respectively, from the par lights **102**, **104**. The measured intensities were 73 fc, 70 fc, and 62 fc, respectively. More specifically, as shown in FIG. **43**, there are three adjacent boxes used as key light and two adjacent boxes used as fill. Both FIGS. **8** and **43** show footcandle readings at eye level where the boxes are hung at about nine feet. The center diffusion screen contained LEE **187** cosmetic rouge gel. The outer gel frame used light grid cloth. The device “defies” the inverse square law of light. Light fall off is less than ½ stop at all points and action areas show less than ¼ stop fall off. The lights on top provide much of the intensity for the far field (upstage). The lights on the bottom provide much of the light in the near field (downstage). The middle area is lit by a mixture of both the upper and lower lights, thus creating the previously unavailable and significantly advantageous ability to evenly light a given action area with one device.

A lighting box **109** according to a second embodiment of the invention is shown in FIG. **9**. It has a shell **110** with four sides **111**, **112**, **113**, **114**. A yoke **116** mounts by two rotatable friction knob assemblies **118** to the shell at the outside of sides **111**, **113**. Each assembly **118** has a mounting plate **120** bolted or otherwise fixed to the shell **110**, a rotatable connector **122** rotatably connected to the plate **120** and having a hole for receiving an end of the yoke **116**. There is a friction knob **124** for fixing the yoke at a desired angle and for loosening the connector **122** to rotate and thereby rotate the yoke to another desired angle. Accordingly, the top side **112** of the shell need not extend out past the bottom side **114**.

A rectangular or square frame **126** has four sides **127–130**. The frame supports a mounting bar **131** which may be a

rectangular bar, or circular rod, fitted at each end into a rectangular (or circular) cup **132** fixed to sides **128**, **130**. The bar **131** may be held in the cups **132** by pins or bolts **133**. Multiple lighting elements, units or instruments **135**, **136** are fixed by mounting elements **138**, such as pipe clamps or a fixed connector to the bar **131** (or rod). The two lights on top, e.g., non-focusable lights such as pars, are preferably of higher intensity than the two lights below, e.g., non-focusable lights such as pars **135**, **136**. The pars on top may be medium and the pars below may be wide. The rectangular frame **126** (“rectangle”) may be put in the shell as shown, or rotated 90° so that the bar **131** is horizontal.

The rectangle screws or bolts to the shell. For example, each side has three holes. Side **127** has holes **127a**, **127b**, **127c** and each side of the shell, e.g., side **111**, has three matching holes, e.g., holes **111a**, **111b**, **111c**, for pinning, screwing or bolting the frame inside the shell. Diffusion frames **142**, **144** may be slid into pairs of C-channel slots **146**, **147** on opposite sides of the shell and upper slots **148**, **149**. The gel frames are held in the box preferably by a mechanism other than the access door being closed. Otherwise, when the door is opened, the frames will fall out. The mechanism is a cotter pin and holes through the shell and in the gel frame, e.g., as shown and described later with respect to FIG. **22**.

As in the prior embodiment, an access door **114a** is hinged to the rest of the side **114** to be openable and closable to enable the diffusion frames, color filters or the like to be readily inserted or replaced. At its front corners, there are two releasable fasteners **150a**, **150b**, e.g., quarter turn fasteners (such as DZUS™ fasteners) which engage receptors or holes **111d**, **113a** to hold the door **114a** in the closed position by being turned 90° with a screwdriver or the like. They readily turn 90° in the other direction to release the door.

Yoke **116** has a threaded pin **116a** for mating with a standard female receptor in an overhead mounting arm **152** (FIG. **13**) or into a stand **154** (FIG. **14**). This box need not have a tilted front face because the whole box can readily have its angle adjusted by adjusting the angle of yoke **116** using the friction knob **124**.

In this embodiment, the rod **131** is shown vertically oriented, but it may also be horizontally oriented as in other embodiments.

As shown in FIG. **10**, side **114** is not connected to side **113**. The shell obtains its structure from connecting the rectangle **126** inside the rear of the shell. Without the rectangle, the shell **110** readily folds up as shown in FIGS. **11** and **12**. Specifically, with reference to FIG. **11**, sides **112** and **113** are connected by a piano hinge **160** and fold together. Sides **111** and **112** are connected by a piano hinge **162** and fold back on each other, so that the entire shell folds up into the length and width of one side, as shown in FIG. **12**.

A modification of the box of FIGS. **9–14** is shown in FIGS. **15–22**. Box **166** has a shell having four sides **167**, **168**, **169**, **170**. Sides **167** and **168** are connected by a piano hinge **172**, sides **168** and **169** are connected by a piano hinge **173**, and sides **167** and **170** are connected by a piano hinge **174**. Side **170** folds counterclockwise in FIG. **16** onto side **167**, and side **169** folds counterclockwise against side **168**. Sides **168**, **169** and **167**, **170** fold together so that sides **169** and **167** are adjacent as shown in FIGS. **16** and **17**. Sides **169** and **170** are not hinged, and may be fixed together by screws, bolts or pins to holes **170a** formed in a flange **170b** of side **170**. Side **170** also has an access door **170c** having a quarter

turn fastener schematically shown as element **170e** in a flange **170d**. The access door **170c** has a symmetrical structure on its opposite end. Access door **170c** also has a piano hinge **176** for being rotatably connected to the rest of side **170**.

With reference to FIGS. **15** and **18–19**, frame assembly **178** for attachment to the housing and for supporting lights includes a rectangular frame member **180**, two triangular frame members **182** screwed or bolted to the rectangular frame members by bolts **184**, and a light mounting rail **186** such as schedule **40**, an industry standard pipe about $1\frac{1}{2}$ " or $1\frac{5}{8}$ " in diameter. At each end of the rail **186**, there is a cup **188** fixed, e.g., by welding, screws or bolts, to a corner of each triangular member **182**. Each end of the pipe slides into each cup, and has a hole. When this hole registers with a hole **190** in the cup, a cotter pin **192** may be inserted therethrough to hold the rail **186** in place.

The frame assembly **178** attaches to the shell at side **168** by bolting, screwing or pinning through holes **180a** in the rectangle and corresponding holes in side **168** (the top). Frame member **180** also has slots **180b** which mate with slots **168a** in side **168** so that eye bolts, pipe hangers or the like may be used to hang the box from or mount the box to scaffolding **196**, a "green bed" or the like (FIG. **23**).

In FIG. **23**, three boxes **166** are shown adjacent one another and two other boxes **166** are also adjacent each other to provide the effect of one larger box. The projected light that comes from such groups of three boxes and two boxes, each having four lights, is the same as or very similar to the projected light from one box having twelve lights and another box having eight lights, respectively, to provide as wide a light as desired. The modular structure of the box is evident from FIG. **23**.

The diffusion frames may readily be removed and replaced by opening access door **170c** in each box by turning the quarter turn fastener to open the access door, then removing a cotter pin **198** holding the gel frame as shown in FIG. **22**. The pin **198** extends through the shell (a hole in side **169**) then through a corresponding hole in the gel frame, and the same applies to side **167**, as shown in FIG. **16**. The diffusion gel frames are thus held in C-channels **199**, **200** inside each side **167**, **169** (FIG. **15**) and two cotter pins hold each of the frames in place.

Four lights may be mounted to rail **186** as in previous embodiments. The two lights on top may be stronger than the two lights on the bottom, also as in previous embodiments.

In FIG. **24**, a fourth embodiment of the invention is shown, where a lighting box **202** is to be disposed overhead. In this embodiment, the box also includes a frame assembly **204**, and a shell **205** mounted to the frame assembly. The frame assembly has a light mounting rod **206** or bar on which multiple lights **208** are mounted by C-clamps **210** or other connection. Rod **206** is connected to a triangle **212** in the same way as in the prior embodiments, e.g., by a pair of cups **207**, welded or otherwise fixed to the triangle **212**, and by cotter pins **209**. The triangle **212** in turn is fastened to a rectangle **214** by screws or bolts or an otherwise readily disconnectable connection, as in prior embodiments. For example, with reference to FIGS. **28** and **33**, triangle **212** has a cross-piece **212b** welded to a side **212a** of the triangle at each end of the cross-piece to **212b**.

The triangle is connected to the rectangle by eyebolts, e.g., four eyebolts **216** located substantially at each corner of the triangle, and attached by wing nuts **218** (FIG. **33**) to the rectangle's short side. The entire box may be suspended by

the four eyebolts **216** using chain or the like. As shown in FIGS. **28**, **35** and **35A**, rectangle **214** is preferably formed in two pieces which fit together on the short sides by a tongue **214a** press or friction fit into an opening **214b** in square tubing forming rectangle **214**.

Shell **205** has four sides **221**, **222**, **223** and **224**. The two short sides **222**, **224** have a piano hinge **225** at their midpoints, so that the shell **205** is collapsible as shown in FIGS. **26** and **27**. As shown in FIG. **24**, rectangle **214** fits inside shell **205** and shell **205** is fixed to frame **214** by bolts **227** and nuts **228**, connected through holes **230** (FIG. **26**). To make the depth dimension of the shell and frame smaller, an additional set of holes **232** may be provided, e.g., six inches from the first set **230**.

The shell also has diffusion gel frame mounting elements **234**, **236** for holding diffusion gel frames **238**, **240**. Each mounting element is contracted as shown in FIG. **37** for element **234**, and is preferably welded to shell **205**. Each gel frame is snapfitted into place, and supported on the mounting element. The embodiment as shown has two pairs of diffusion gel frame mounting elements **234**, **236** on each long side **221**, **223** of the shell. Each gel frame **238**, **240** is preferably foldable on its short sides, e.g., by a hinge pin **240** and a cotter pin **242** fitted through mating holes **244**, **246** as shown in FIGS. **34** and **34A**. One part **238a** of the gel frame fits into another part **238b**. The short sides thus fold like the shell does (FIGS. **26–27**).

FIG. **36** shows the same box **202** as in FIG. **24**, except that the rectangle **214** is bolted to the additional set of holes **232** set deeper into the shell **205**.

FIG. **38** shows a box **202a** which is a variation of box **202** of FIG. **24** having a Socopex™ connector box **260** or equivalent, i.e., a multiconnection electrical box connected to lights **208**. The lights **208** each have a yoke **251** fastened to rod **206** by bolts **250** and nuts as shown in FIG. **39**. This connection to rod or bar **206** is used in place of C-clamps or other readily removable attachments, because box **202a** of FIG. **39** has lights **208** wired to connector box **260** which in turn may be connected to a multi-line cable, which in turn is connected to a light control panel known as a dimmer board. In this way, each individual light may be turned on, off, or dimmed. In, e.g., a six-light box held overhead, one can use four pars on the outside and two blue lights in the center. The blue will be used for "night" shots, four outside pars at full power for "day" shots, and at half power for "dusk" shots.

FIG. **40** shows a fifth embodiment. A box **270** is similar to box **202a** of FIG. **38**, but instead of rigid shell **205** it has a soft, collapsible shell **272** of, e.g., a dark or black fabric preferably with a silver or light interior. The fabric is fixed to triangle **214** by pins, adhesive or other means including removable and reattachable connections. In this embodiment, the gel frames **238**, **240** are the same as in the previous embodiment, except that they are connected at their corners to a chain **274**. With this structure, the entire box may be collapsed when not in use and take very little room. It is also extremely light. This box may utilize the chain and fabric because it is hung overhead. In a preferred embodiment, each top hanging box has ten lights, but many multiple light number arrangements are possible.

FIG. **41** shows a sixth embodiment which is similar to the box of FIG. **40**. However, a box **280** has six par lamps in collars **282** located therein. In this embodiment, the lamps may be in collars to have a smaller depth and less weight. The lamp is held in the collar by a retaining ring (not shown) and there may also be a safety screen in front of each lamp

(not shown). Because the cans are not used in this embodiment, a rear cover (described below) is used to protect against touching wiring and the hot lights. In addition, a front cover (to protect wiring)(not shown), may be used, and could be made of a thin sheet of aluminum with six round cut-outs for the collars.

It is noted that built-in lamps can also be used in the prior embodiments. Because these par lamps in collars have a low profile, they are set into the box and the box may have the rear cover **284** hinged to a rectangular frame **286**. Frame **286** has four eyebolts **288** for hanging the box **280** and the bolts may also function to hold chain **294**. The par collars **282** are directly connected to frame **286** by screws, bolts **289** or the like. The lights **282** are also connected to a Socoplex™ connector **290** or equivalent, by wires **291**. The gel frames **292**, **293** are similar to the embodiment of FIG. **24**, but may collapse on the long sides as shown, and/or the short sides if desired. Moreover, the rectangle **286** (e.g., 20" by 40") may be smaller than the gel frames. The gel frames are held at their corners by chain **294**. A fabric or flexible cover **295** may hang below the lower gel frame **293**. The rear cover is preferably a metal, such as aluminum, and has perforations **298** for cooling/venting.

In place of the Socoplex™ connector, in this embodiment as well as others, toggle switches for each lamp may be placed on the side of the shell, along with a standard 3-pin connector for supplying power, e.g., **100A**, to each lamp unit.

A box **300** of FIG. **42** according to a sixth embodiment is similar to box **280** of FIG. **41**, but it has a yoke **302** hinged to a flange **304** of a rectangular frame **306**. The yoke **302** operates the same as in the embodiment of FIG. **9**. The gel frames **304**, **305** are the same as in the previous embodiment, but are connected by rigid elements **307**, e.g., square tube made out of aluminum. Cloth cover **308** extended at one long side to provide for an angled top as in other embodiments, but may also be made square. The gel frame **305** may accordingly also be angled to match or otherwise shaped to match the desired shape of collar **308**. This box may be used in the same manner as the box of FIG. **9**. Due to its rigid connector elements **307**, it need not hang.

In the embodiments of FIGS. **41** and **42**, with built-in pre-wired lamps, a protective aluminum sheet may be placed at the front face of the lamps, extending for the inner dimensions of the rectangle **286**, and having circular cut-outs corresponding to each lamp face. Moreover, a mesh may be placed over each lamp face as a safety feature in the unlikely event of a blow-out.

In several embodiments, the invention provides the advantages of avoiding boom shadows and providing better sound by using closer booms, creating less heat for a higher light level, and making "actors' marks" less critical due to the large area of sufficient light. The invention may also avoid the need to refocus lights even if scene blocking changes. The invention further enables the use of inexpensive lights, such as par 64's, and provides a fully illuminated action area in which even a single lamp burnout is not critical. The modularity of the invention enables multiple boxes to be used side-to-side like a single large unit. The boxes may also be hung from a single point or multiple points.

The device provides a wide variety of light levels, creates a mood, enhances special lighting and works for daylight, sunset, night shots and more.

The device may be constructed with aircraft quality aluminum such as 6061T6. Inside surfaces are preferably

reflective metal. Light mount and support brackets are preferably welded tubular aluminum construction with a 1½ inch or 1⅝ inch outside diameter pipe for direct fixture mounting.

The box is hinged and foldable. Access to diffusion/color frame slots is from the bottom via a hinged door with quarter turn fasteners. The device when opened will measure approximately 4×4×4 feet and weigh less than 100 pounds.

For mounting purposes, there are three slotted grooves for C-clamps. C-clamps may be mounted in various positions to accommodate balance and angle.

The box can be folded for storage and transportation. In the folded position, the box will measure approximately 4×4 feet×5 inches. Light mounting rails and braces can be stored flat for space saving and ease of transportation.

Soft lights or bounce lights are often used to eliminate shadows. However, they have one great deficiency: as the distance from this light grows, the light fall off is extreme. When light levels in the upstage production areas are inadequate, additional lighting equipment must be added. These added lights cause problems, particularly for microphones and booms. The box was designed to solve this problem, enabling the user to have a more even light level from front to back. The box helps eliminate additional lighting equipment and the boom problems (both access and shadow) that they create in the upstage areas.

The box theory is that a soft projected front light is flattering to actors and eliminates boom shadows. All action areas are lit so new blocking does not call for refocus. Since the multiple sources are used for key, there is not waiting to change burnouts. The box is a fast, cost-effective lighting method that looks great.

In the overhead box embodiments, where ten 1000 watt par cans are used and the box is mounted eleven feet above an area to be lit, such as a boxing ring (20'×20'), a soft even 300 f.c. light is produced over the entire area. Multiple mounting holes allow for a 1×2 inch wood strip to be fixed to the box so that a duvatine skirt may be added to block the spill. The skirt can be black, reflective or diffusing.

Like the other boxes, the overhead version is hinged and foldable for easy, convenient transportation and storage. Access to diffusion/color frame slots is from the bottom, where they snap in place. When fully opened, the box measures 40×60 inches and provides two diffusion/color frame slots.

The invention enables the inexpensive lights to be separated and spaced from one another, preferably a distance of equal to or about the diameter of each light. For example, in a 40" long box, three par cans of diameters of 8" may be placed 8" apart. Six 1000 watt pars can be used to obtain more light, e.g., twice as much light as a 10,000 watt fresnel light when projected through the diffusion elements, yet still weigh much less and cost much less than that single fresnel.

The boxes, when used modularly or collectively, achieve a very desirable lighting effect, and thus it is preferable to form them such that they can be placed side to side, e.g., by using sides **4**, **6**.

Although the boxes are constructed primarily of aluminum, they may be constructed of any other reasonable material including wood, plastic, foamcore, or fabric on a frame, and may even be disposable. The boxes are, as shown in the preferred embodiment, preferably readily enabled to be disassembled and folded, although other embodiments where the boxes are not readily disassembled can be envisioned. In addition, for example, the bar **14** need not be

15

mounted to V-bracket members, and may instead be directly or more directly mounted to the housing of the box. The box or boxes need not be mounted to a green bed, and may be hung from or mounted on pipe, or otherwise mounted, hung or used.

As noted above, a significant advantage of the box is that it creates a soft projected light from inexpensive but powerful and efficient lighting elements, e.g., pars. A further advantage of pars is that they are available in a variety of intensities, e.g., 200 W and 500 W, as well as 1000 W, and a variety of circumferences and intensities. Where lower power pars, e.g., 200 W and 500 W, are used, the box may be scaled down in size accordingly.

While the present invention has been described with regards to particular embodiments, it is recognized that additional variations of the present invention may be devised without departing from the inventive concept.

What is claimed is:

1. A lighting projection device for controlling and directing light from multiple lights, the lighting projection device comprising:

- (i) a housing having multiple sides and a front, wherein the sides are adjacent one another;
- (ii) a frame for supporting the housing, the frame comprising lamp holding means for receiving and holding multiple par lamps;
- (iii) multiple par lamps supported in the lamp holding means; and
- (iv) means in the housing for supporting a primary diffusion element holder proximate the front of the housing, whereby when a primary diffusion element is disposed in the primary diffusion element holder, light diffusion will be provided for converting light from the par lamps directed thereat to a soft diffused projected light.

2. The lighting device of claim 1 wherein there are at least six par lamps mounted in the lamp holding means and positioned in rows and columns each having at least two par lamps.

3. The lighting device of claim 1 further comprising means for connecting sides of the frame for folding with respect to each other so as to fold to a planar form.

4. The lighting device of claim 1, wherein the housing comprises a fabric material.

5. The lighting device of claim 1, wherein the housing comprises a duvatine skirt.

6. The lighting device of claim 1, wherein the primary diffusion element holder comprises a rigid rectangular member.

7. The lighting device of claim 1, wherein the housing is enclosed at the sides at least from a position proximate the front of the par lamps to the front of the housing.

8. The lighting device of claim 1, wherein the housing has an inner surface comprising a reflective material.

9. The lighting device of claim 1, further comprising means attached to the frame for suspending the lighting device.

10. The lighting device of claim 1, wherein the sides extend at least from the frame to the primary diffusion element holder.

11. The lighting device of claim 1, wherein the sides enclose light from the par lamps such that the light only passes through the primary diffusion element holder.

12. The lighting device of claim 1, further comprising means for providing access to said primary diffusion element holder for removing and replacing said primary diffusion element holder.

16

13. The lighting device of claim 1, further comprising means attached to the frame for suspending the lighting device.

14. The lighting device of claim 1, wherein the frame has four corners proximate a rear thereof, and further comprising means attached to the frame at four points proximate the four corners thereof, respectively, for hanging the lighting device.

15. The lighting device of claim 1, further comprising a yoke attached to the frame for pivotably holding the lighting device.

16. The lighting device of claim 1, wherein the frame has built-in par lamps disposed therein.

17. The lighting device of claim 16, wherein the par lamps are wired individual to a multiple pin connector for individual control of each of the par lamps.

18. The lighting device of claim 1, wherein a primary diffusion element is disposed in the primary diffusion element holder.

19. The lighting device of claim 18, wherein the primary diffusion element is a material that diffuses the light from the par lamps.

20. The lighting device of claim 18, wherein the primary filter element is a material that alters the color of the light from the par lamps.

21. The lighting device of claim 1, further comprising a secondary diffusion element holder, wherein the secondary diffusion element holder is supported in the housing proximate the front such that, when diffusion elements are mounted in the primary diffusion element holder and the secondary diffusion element holder, light produced by the plurality of par lamps is directed therethrough.

22. The lighting device of claim 21, wherein a primary diffusion element is disposed in the primary diffusion element holder and a secondary diffusion element is disposed in the secondary diffusion element holder.

23. The lighting device of claim 22, wherein the secondary diffusion element is a material that diffuses the light from the par lamps.

24. The lighting device of claim 22, wherein the secondary diffusion element is a material that alters the color of the light from the par lamps.

25. The lighting device of claim 1, wherein the frame comprises a member having a rectangular cross section with the par lamps disposed inside the rectangular member.

26. The lighting device of claim 25, wherein the par lamps each comprise a collar fixed to the rectangular member and a par light disposed in the collar.

27. The lighting device of claim 25, wherein the means for supporting the primary diffusion element holder comprises one of rigid bars and chains connected to the frame.

28. The lighting device of claim 26, further comprising means for protecting a user from heat generated by the par lamps disposed on a side of the par lamps opposite to the front of the housing.

29. The lighting device of claim 28, wherein the means for protecting comprises a cover.

30. The lighting device of claim 29, wherein the cover has perforations.

31. A lighting device for lighting by front projection lighting a stage or set, the lighting device comprising:

- a housing having multiple adjacent sides and a front;
- a frame for mounting the housing and comprising lamp holding means for supporting multiple par lamps;
- at least two diffusion element holders mounted in the housing spaced from one another and proximate the front of the housing and in front of the lamp holding means; and

multiple par lamps mounted in the lamp holding means to shine light through the diffusion element holders, whereby the multiple par lamps provide soft projected diffused light from the lighting device for lighting a stage or set when diffusion elements are provided in the diffusion element holders.

32. The lighting device of claim 1, wherein there are at least six par lamps mounted in the lamp holding means and positioned in rows and columns each having at least two par lamps.

33. The lighting device of claim 31 further comprising means for connecting sides of the frame for folding with respect to each other so as to fold to a planar form.

34. The lighting device of claim 31, wherein the housing comprises a fabric material.

35. The lighting device of claim 31, wherein the housing comprises a duvatine skirt.

36. The lighting device of claim 31, wherein the primary diffusion element holder comprises a rigid rectangular member.

37. The lighting device of claim 31, wherein the housing is enclosed at the sides at least from a position proximate the front of the par lamps to the front of the housing.

38. The lighting device of claim 37, wherein the housing has an inner surface comprising a reflective material.

39. The lighting device of claim 37, further comprising means attached to the frame for suspending the lighting device.

40. The lighting device of claim 37, wherein the sides extend at least from the frame to the primary diffusion element holder.

41. The lighting device of claim 37, wherein the sides enclose light from the par lamps such that the light only passes through the diffusion element holders.

42. The lighting device of claim 37, further comprising means for providing access to the diffusion element holders for removing and replacing the diffusion element holders.

43. The lighting device of claim 37, further comprising means attached to the frame for suspending the lighting device.

44. The lighting device of claim 37, wherein the frame has four corners proximate a rear thereof, and further comprising means attached to the frame at four points proximate the four corners thereof, respectively, for hanging the lighting device.

45. The lighting device of claim 37, further comprising a yoke attached to the frame for pivotably holding the lighting device.

46. The lighting device of claim 37, wherein the frame has built-in par lamps disposed therein.

47. The lighting device of claim 46, wherein the par lamps are wired individually to a multiple pin connector for individual control of each of the par lamps.

48. The lighting device of claim 37, further comprising means for supporting the diffusion element holders on the frame.

49. The lighting device of claim 48, wherein the means for supporting the diffusion element holders comprises one of rigid bars and chains connected to the frame.

50. The lighting device of claim 37, wherein a primary diffusion element is disposed in one of the diffusion element holders and a secondary diffusion element is disposed in the other of the diffusion element holders.

51. The lighting device of claim 50, wherein the primary and secondary diffusion elements are a material that diffuses the light from the par lamps.

52. The lighting device of claim 50, wherein the primary and secondary diffusion elements are a material that alters the color of the light from the par lamps.

53. The lighting device of claim 37, wherein the frame comprises a member having a rectangular cross section with the par lamps disposed inside the rectangular member.

54. The lighting device of claim 53, wherein the par lamps each comprise a collar fixed to the rectangular member and a par light disposed in the collar.

55. The lighting device of claim 54, further comprising means for protecting a user from heat generated by the par lamps disposed on a side of the par lamps opposite to the front of the housing.

56. The lighting device of claim 54, wherein the means for protecting comprises a cover.

57. The lighting device of claim 56, wherein the cover has perforations.

58. A method of lighting a stage or set using at least one lighting device, wherein the lighting device comprises a housing a contiguous closed portion and a front, and means for mounting at least four par lamps, the method comprising the steps of:

(i) providing a diffusion frame with a diffusion element proximate the front of the housing;

(ii) providing a frame for holding the at least four par lamps therein and for supporting the housing;

(iii) positioning the frame with the at least four par lamps proximate a rear of the housing directed towards the diffusion element at the front of the housing, with the housing being enclosed at least from the par lamps to the diffusion element;

(iv) diffusing light from each of the at least four par lamps using the diffusion element; and

(v) using the diffused light exiting the diffusion element to illuminate at least part of a stage or set.

59. The method of claim 58, further comprising a step of using lighting devices as a primary means of lighting a set.

60. The method of claim 58, further comprising a step of positioning the lighting device at a front of the set to illuminate the set from the front.

61. A lighting device for directing and controlling light from at least four nonfocusable par lamps, the lighting device comprising:

a housing having four sides, a front and a back; at least four par lamps;

a rigid member for mounting the par lamps in the housing, and for mounting the housing;

primary means for diffusing light from the multiple par lamps, the primary means for diffusing disposed proximate the front of the housing for forming a soft, projected and diffused light from the par lamps when disposed in the housing and directed at the primary means for diffusing.

62. The lighting device of claim 61, wherein there are at least six par lamps mounted in the lamp holding means and positioned in rows and columns each having at least two par lamps.

63. The lighting device of claim 61, further comprising means for connecting sides of the frame for folding with respect to each other so as to fold to a planar form.

64. The lighting device of claim 61, wherein the housing comprises a fabric material.

65. The lighting device of claim 61, wherein the housing comprises a duvatine skirt.

66. The lighting device of claim 61, further comprising frame means for supporting the primary means for diffusing.

67. The lighting device of claim 61, wherein the housing is enclosed at the sides at least from a position proximate the front of the par lamps to the front of the housing.

19

68. The lighting device of claim 61, wherein the housing has an inner surface comprising a reflective material.

69. The lighting device of claim 61, further comprising means attached to the frame for suspending the lighting device.

70. The lighting device of claim 61, wherein the sides extend at least from the frame to the primary diffusion element holder.

71. The lighting device of claim 61, wherein the sides enclose light from the par lamps such that the light only passes through the primary diffusion element holder.

72. The lighting device of claim 61, further comprising means for providing access to said primary means for diffusing for removing and replacing said primary means for diffusing.

73. The lighting device of claim 61, further comprising means attached to the frame for suspending the lighting device.

74. The lighting device of claim 61, wherein the frame has four corners proximate a rear thereof, and further comprising means attached to the frame at four points proximate the four corners thereof, respectively, for hanging the lighting device.

75. The lighting device of claim 61, further comprising a yoke attached to the frame for pivotably holding the lighting device.

76. The lighting device of claim 61, wherein the frame has built-in par lamps disposed therein.

20

77. The lighting device of claim 76, wherein the par lamps are wired individually to a multiple pin connector for individual control of each of the par lamps.

78. The lighting device of claim 61, further comprising secondary means for diffusing light from the par lamps after the light passes through the primary means, wherein the secondary means is supported in the housing proximate the front.

79. The lighting device of claim 78, wherein there are two diffusion element holders for holding the primary and secondary means for diffusing in the housing.

80. The lighting device of claim 61, wherein the frame comprises a member having a rectangular cross section with the par lamps disposed inside the rectangular member.

81. The lighting device of claim 80, wherein the par lamps each comprise a collar fixed to the rectangular member and a par light disposed in the collar.

82. The lighting device of claim 81, further comprising means for protecting a user from heat generated by the par lamps disposed on a side of the par lamps opposite to the front of the housing.

83. The lighting device of claim 82, wherein the means for protecting comprises a cover.

84. The lighting device of claim 83, wherein the cover has perforations.

* * * * *