



US006712486B1

(12) **United States Patent**  
**Popovich et al.**

(10) **Patent No.:** **US 6,712,486 B1**  
(45) **Date of Patent:** **Mar. 30, 2004**

(54) **MOUNTING ARRANGEMENT FOR LIGHT EMITTING DIODES**

(75) Inventors: **John Popovich**, Solana Beach, CA (US); **Gregory W. Honegger**, Bakersfield, CA (US)

(73) Assignee: **Permlight Products, Inc.**, Tustin, CA (US)

(\*) Notice: Subject to any disclaimer, the term of this patent is extended or adjusted under 35 U.S.C. 154(b) by 0 days.

(21) Appl. No.: **09/693,548**

(22) Filed: **Oct. 19, 2000**

**Related U.S. Application Data**

(60) Provisional application No. 60/200,531, filed on Apr. 27, 2000, and provisional application No. 60/160,480, filed on Oct. 19, 1999.

(51) **Int. Cl.**<sup>7</sup> ..... **F21V 121/02**

(52) **U.S. Cl.** ..... **362/249**; 362/800; 361/719; 361/720

(58) **Field of Search** ..... 366/800, 131, 366/249, 252, 816; 361/760, 719, 715, 720, 721; 257/718, 719, 726, 721

(56) **References Cited**

**U.S. PATENT DOCUMENTS**

4,143,411 A	3/1979	Roberts	362/145
4,612,606 A	9/1986	Roberts	362/146
4,855,882 A	8/1989	Boss	362/238

4,908,743 A	3/1990	Miller	362/238
5,222,799 A	6/1993	Sears et al.	362/146
5,746,497 A *	5/1998	Machida	362/800
5,857,767 A	1/1999	Hochstein	362/294
6,244,728 B1 *	6/2001	Cote et al.	362/800
6,350,039 B1 *	2/2002	Lee	

**OTHER PUBLICATIONS**

Hewlett Packard, Super Flux LED's, pp. 1-25, 1-26, and ii. Hewlett Packard, Angeline Wong, Subminiature InGaN Blue Lamps, pp. 1-2, Aug. 4, 1998.

Hewlett Packard, Thermal Management Considerations for Super Flux LEDs, Application Note 1149-4, pp. 1-5.

Hewlett Packard, Subminiature High Performance AllnGaP LED Lamps, Technical Data, pp. 1-161-1-162.

\* cited by examiner

*Primary Examiner*—Laura K Tso

(74) *Attorney, Agent, or Firm*—Knobbe, Martens, Olson & Bear, LLP.

(57) **ABSTRACT**

A modular light emitting diode (LED) mounting configuration is provided including a light source module having a plurality of pre-packaged LEDs arranged in a serial array. The module includes a heat conductive body portion adapted to conduct heat generated by the LEDs to an adjacent heat sink. As a result, the LEDs are able to be operated with a higher current than normally allowed. Thus, brightness and performance of the LEDs is increased without decreasing the life expectancy of the LEDs. The LED modules can be used in a variety of illumination applications employing one or more modules.

**63 Claims, 19 Drawing Sheets**

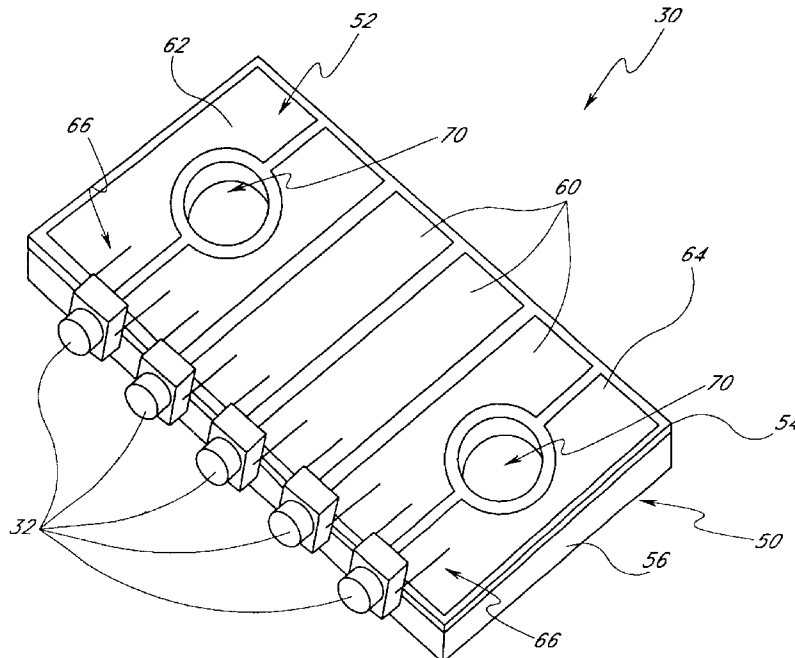

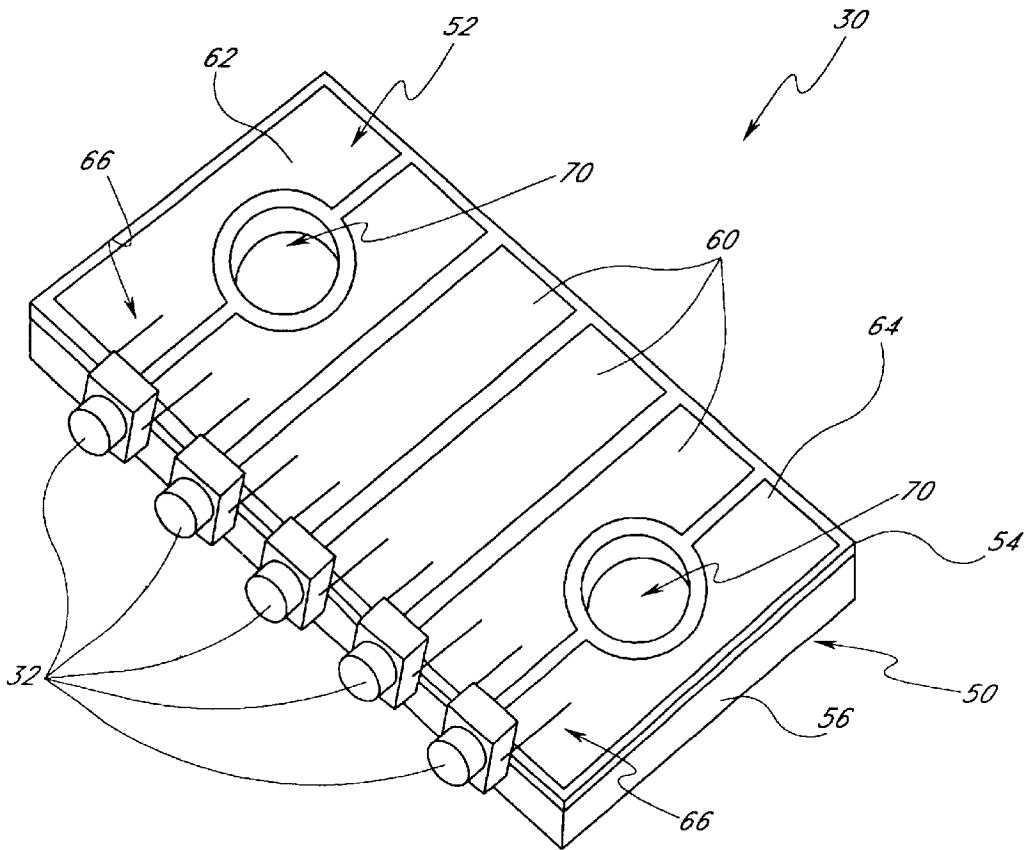

FIG. 1

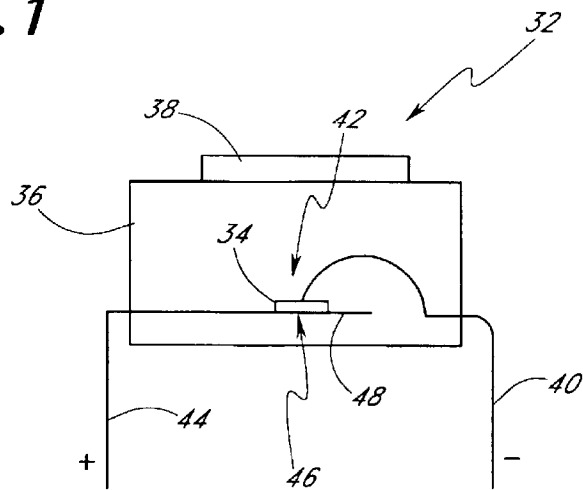

FIG. 2

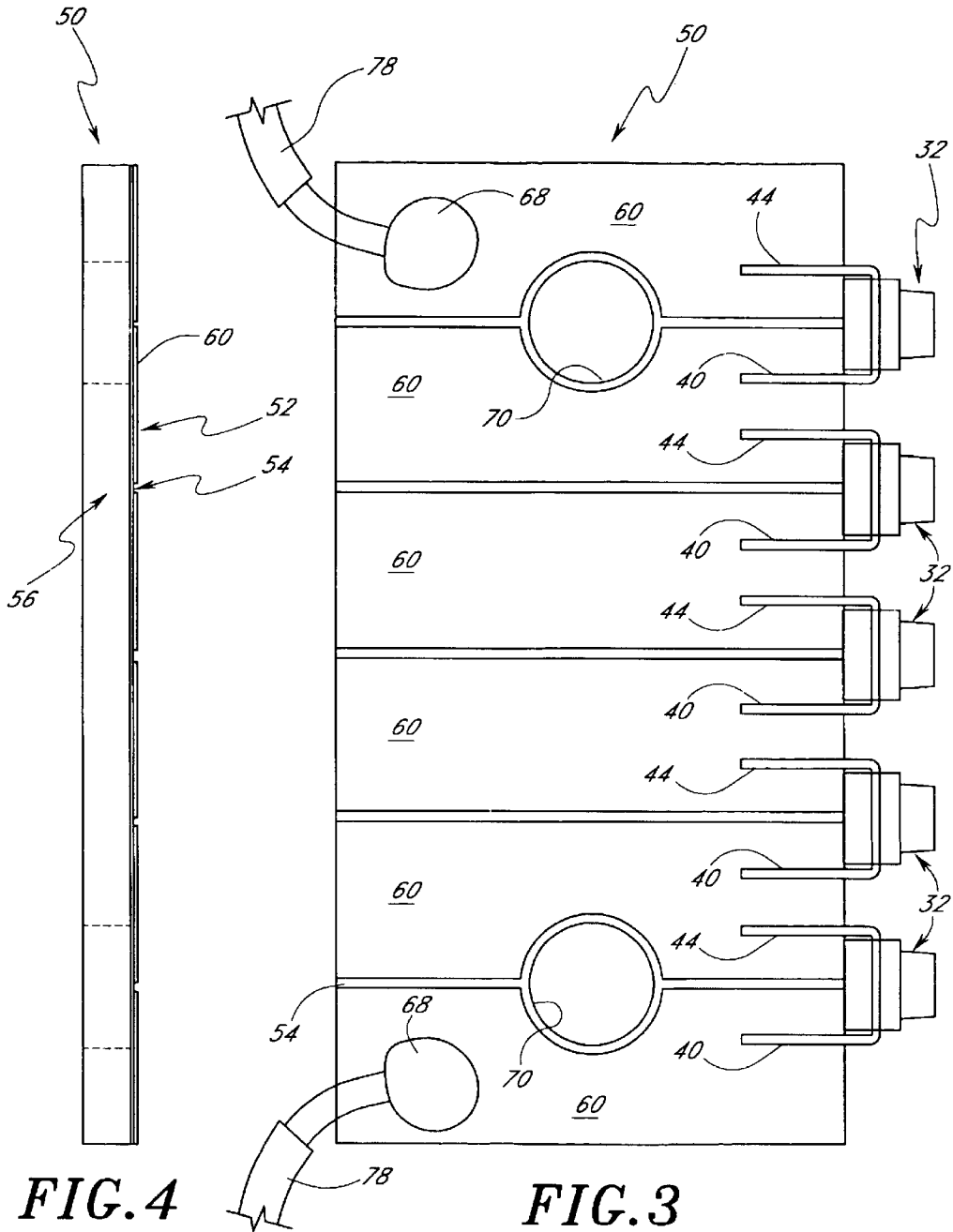
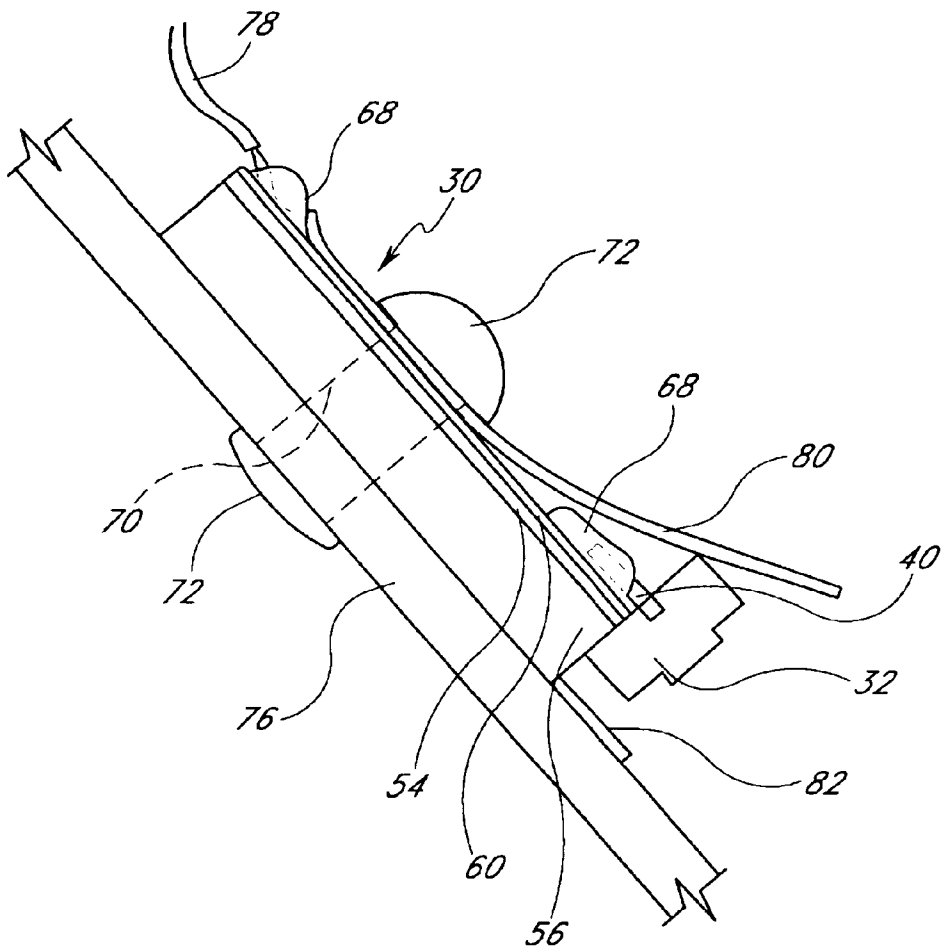
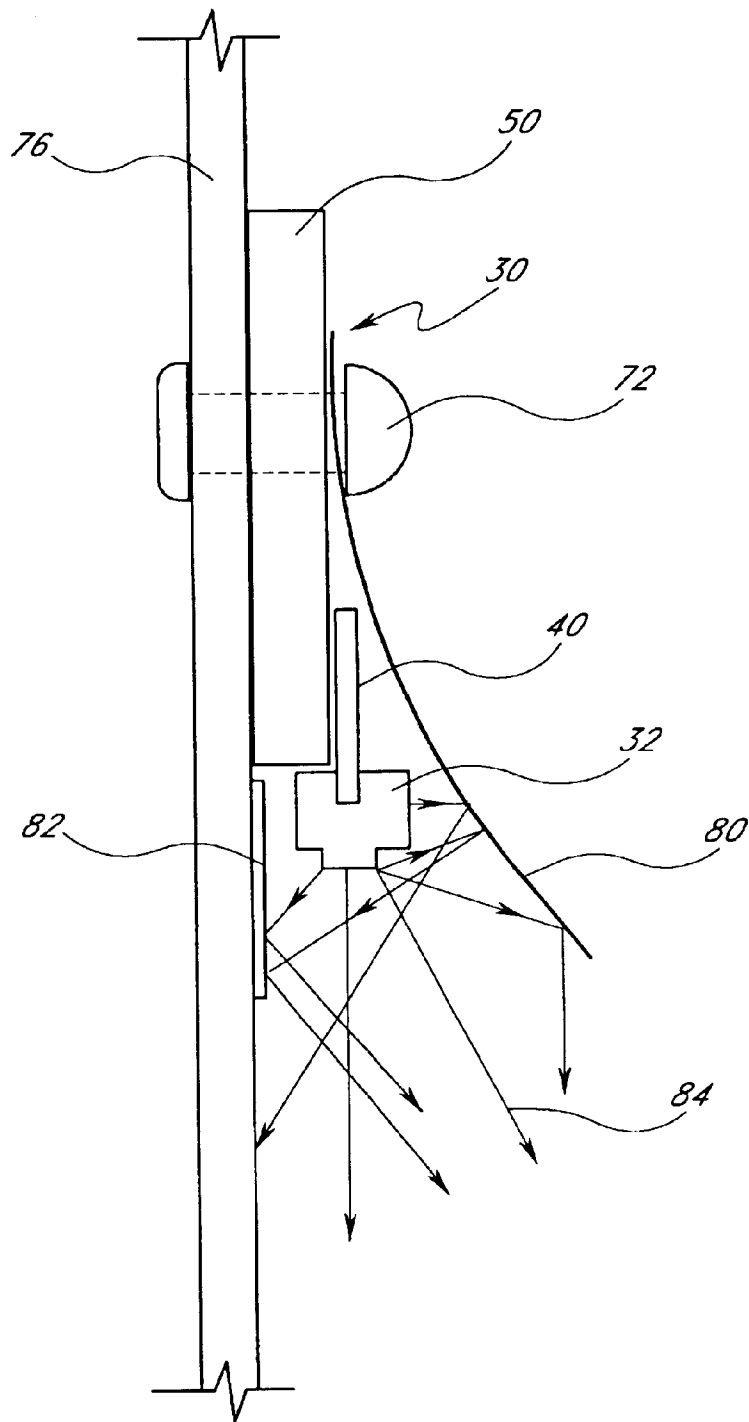

FIG. 4

FIG. 3



**FIG. 5**



**FIG. 6**

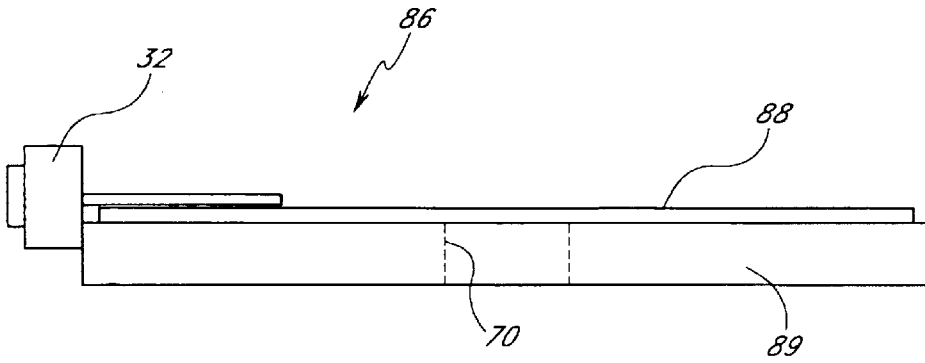

FIG. 7

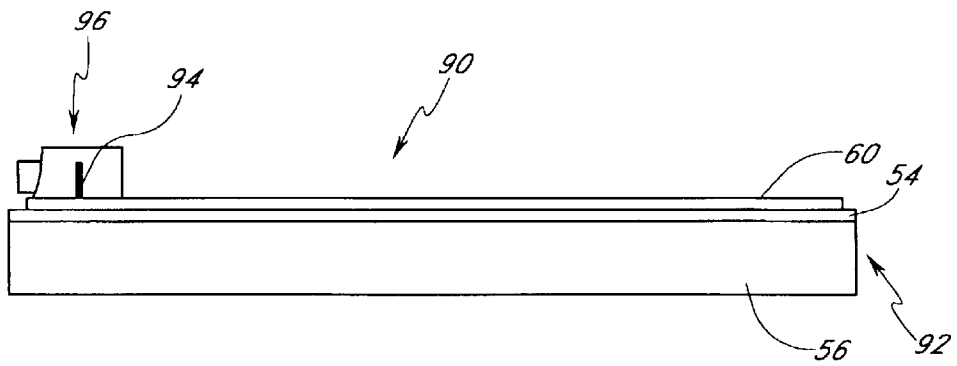

FIG. 8

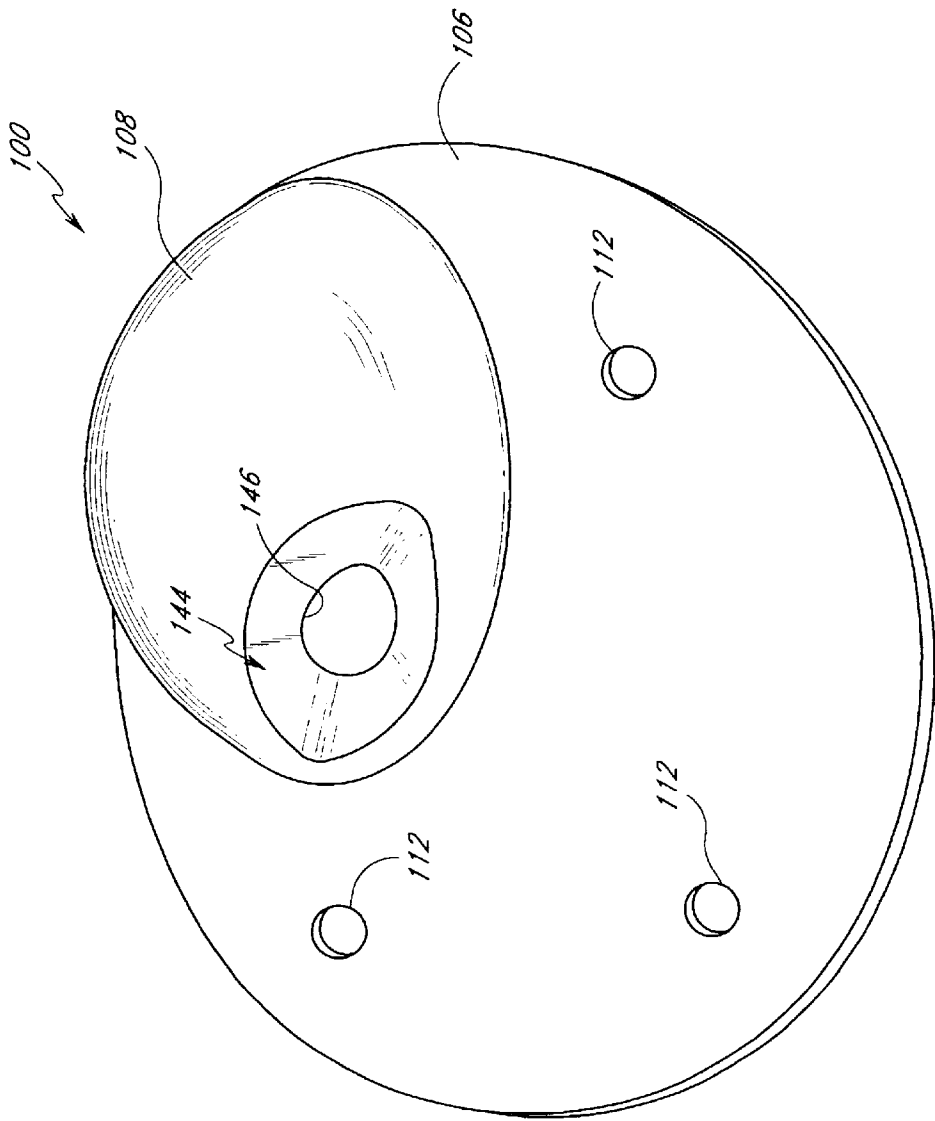

FIG. 9

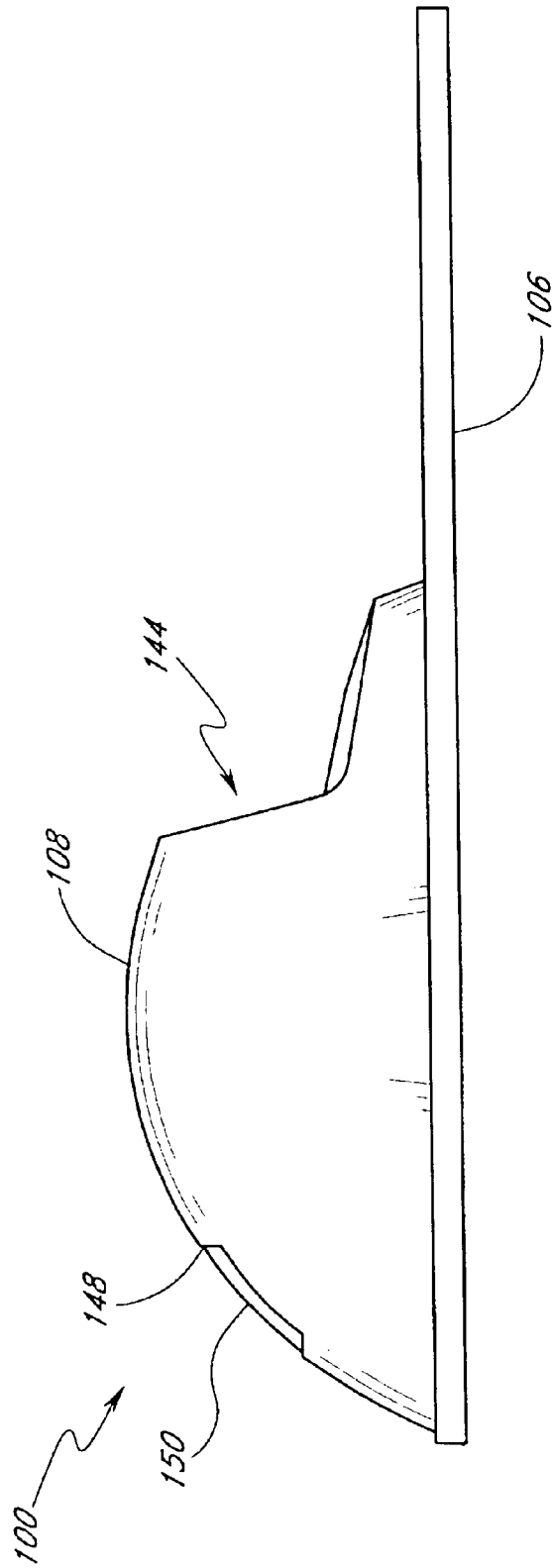

FIG. 10

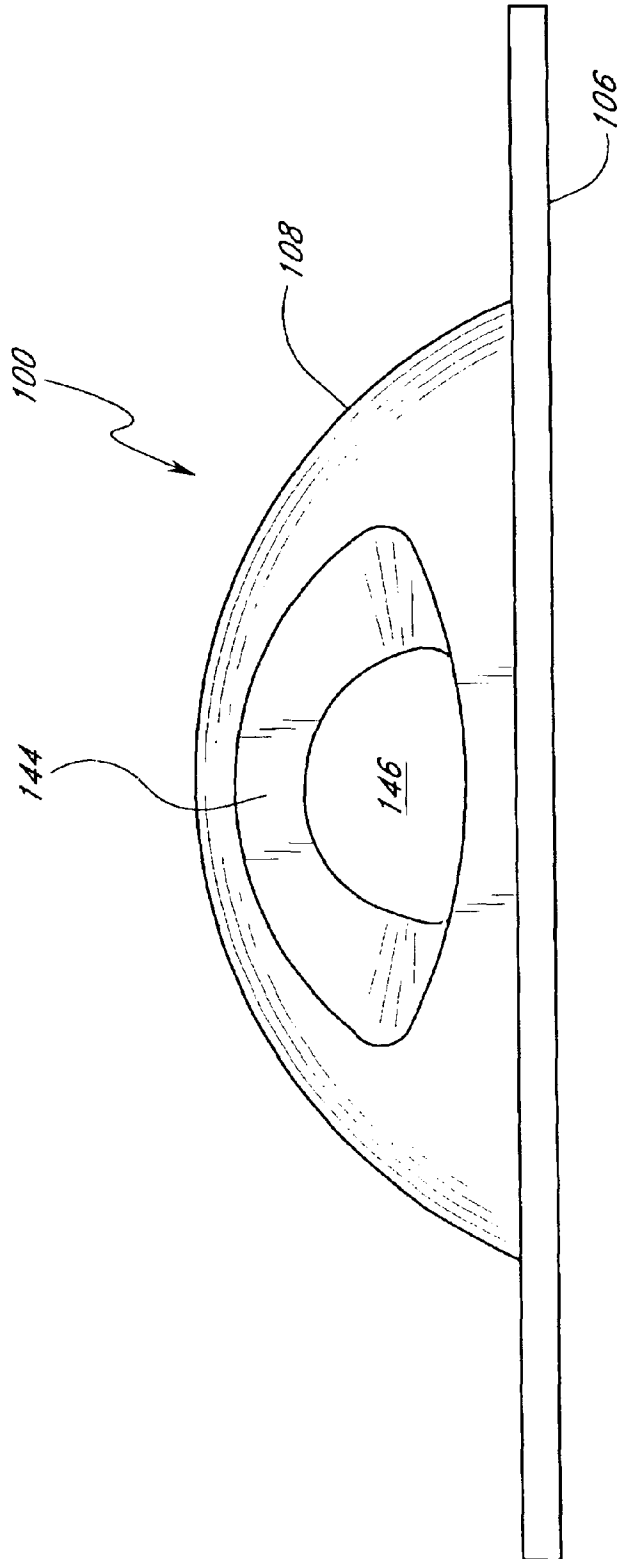
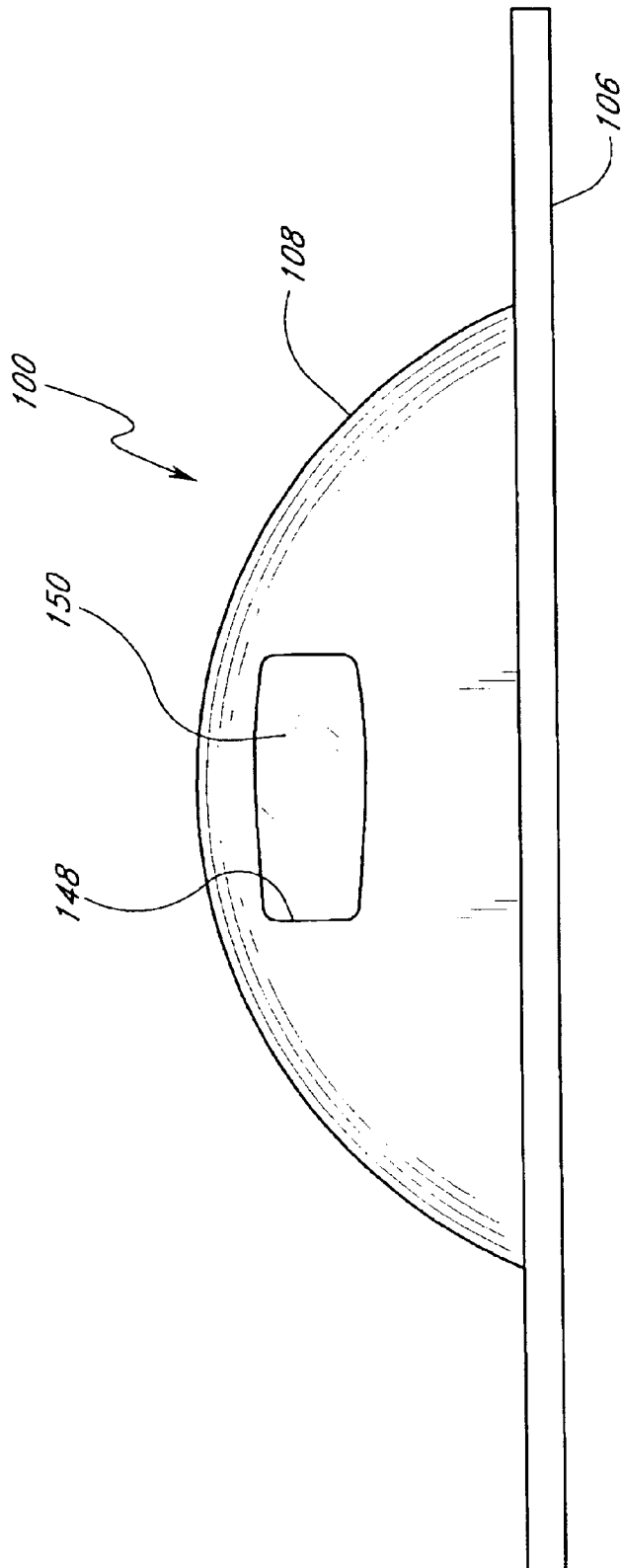
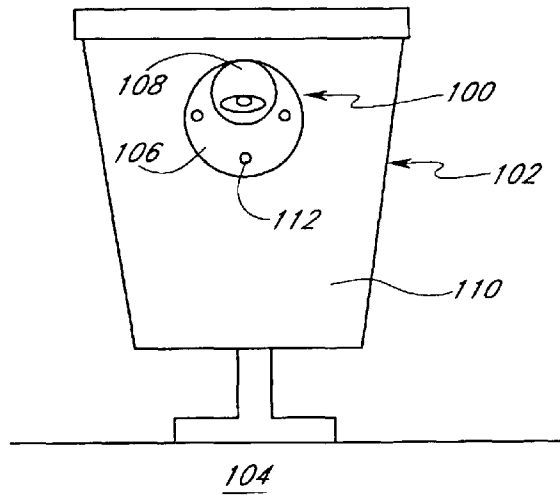

FIG. 11



**FIG. 12**



**FIG. 13**

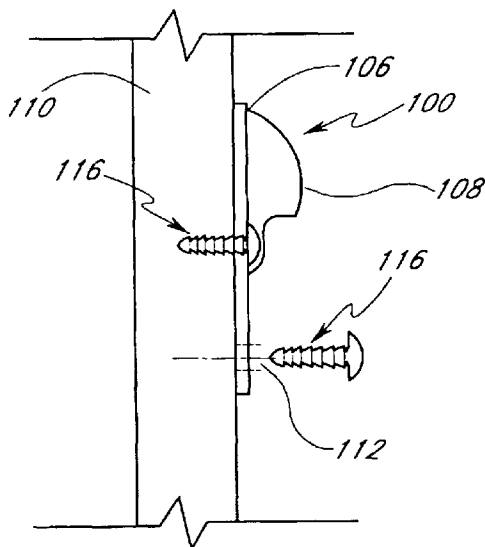

**FIG. 14**

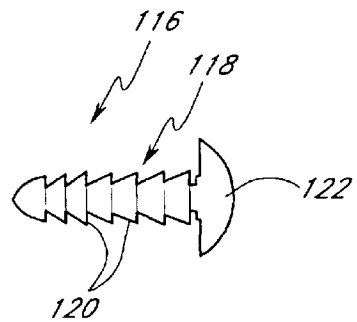

**FIG. 15**

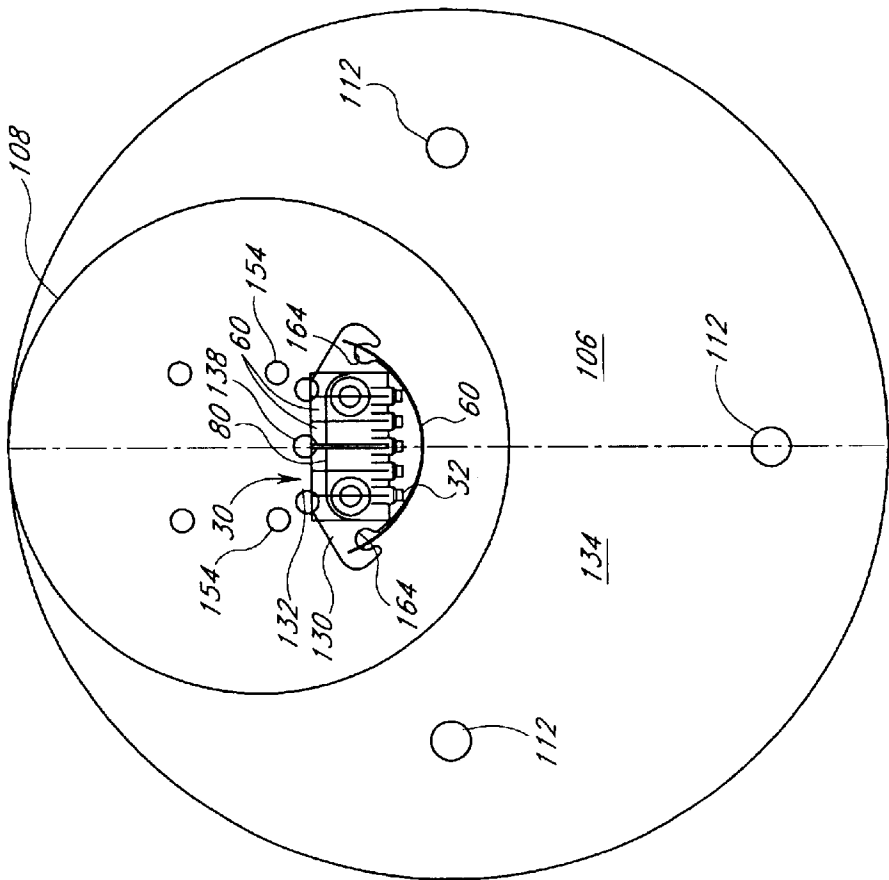

FIG. 16

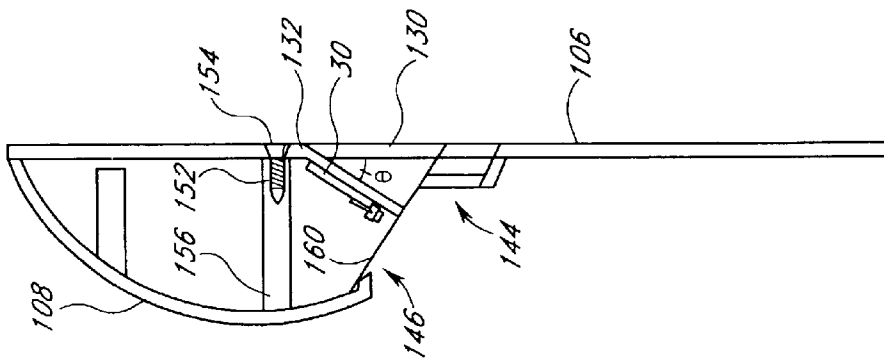
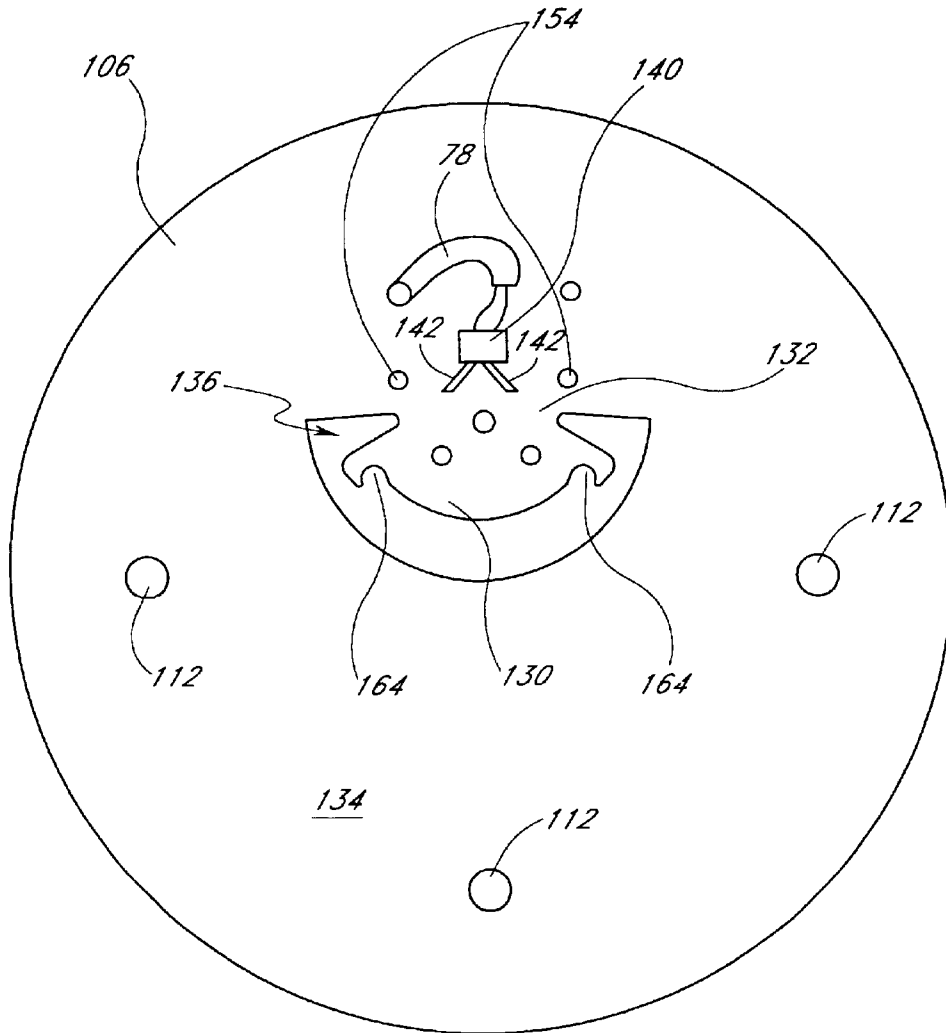

FIG. 17



**FIG. 18**

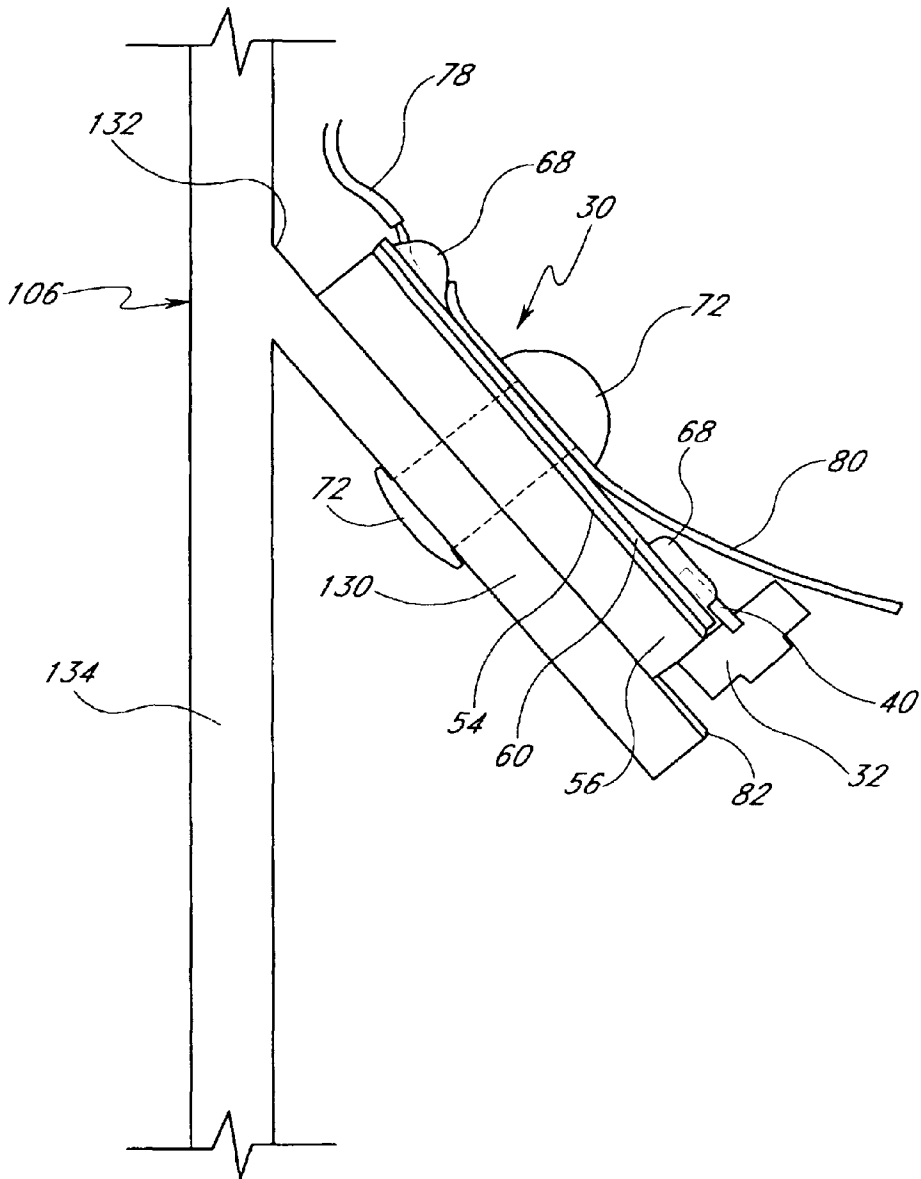
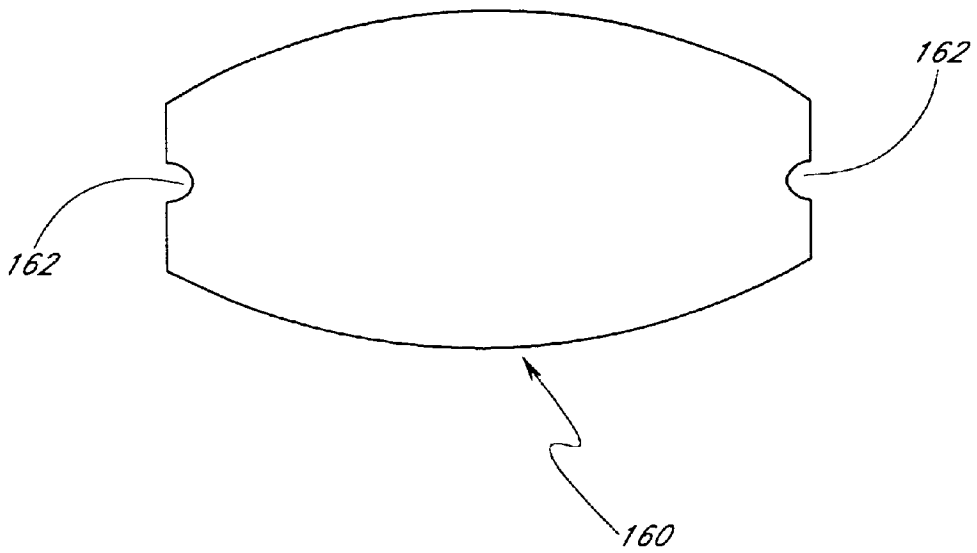
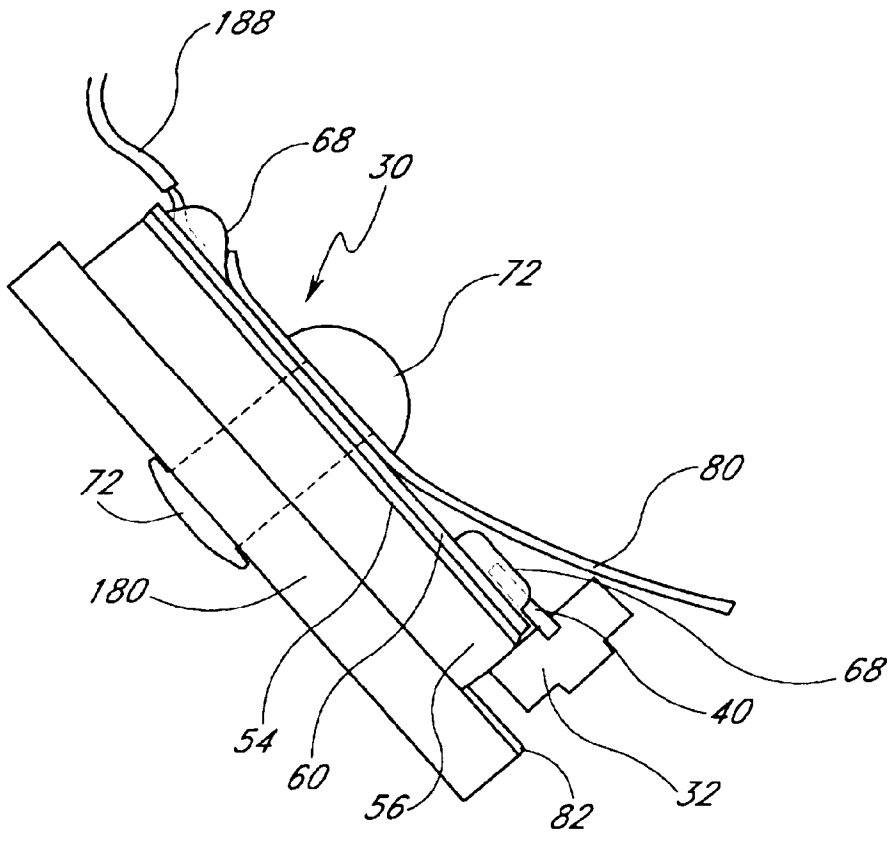

FIG. 19



**FIG. 20**





**FIG. 22**

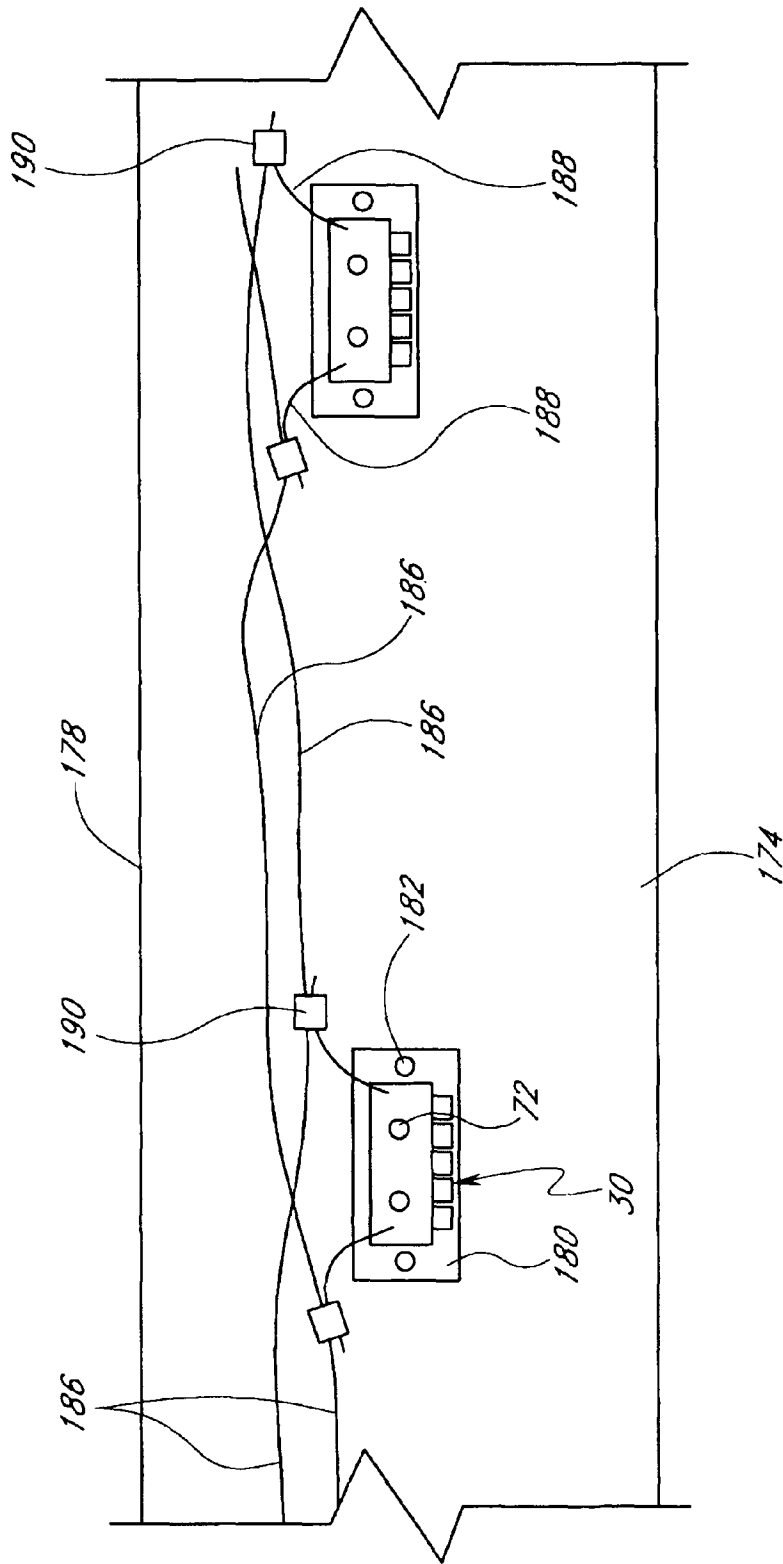
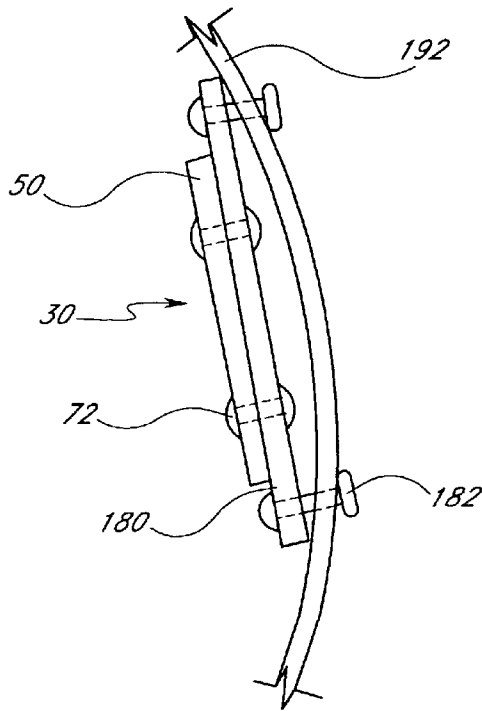
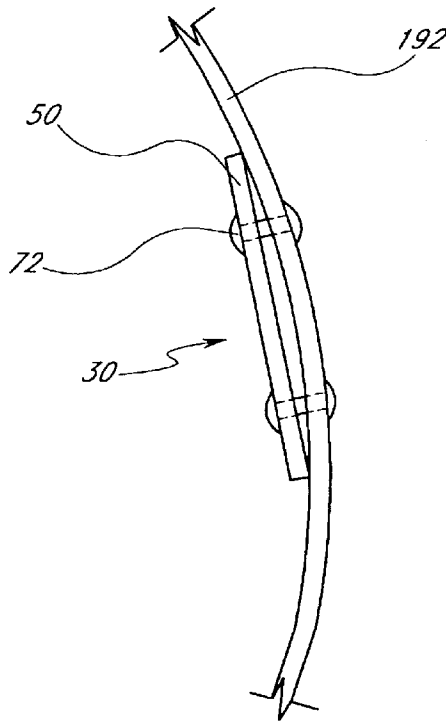

FIG. 23



**FIG. 24**



**FIG. 25**

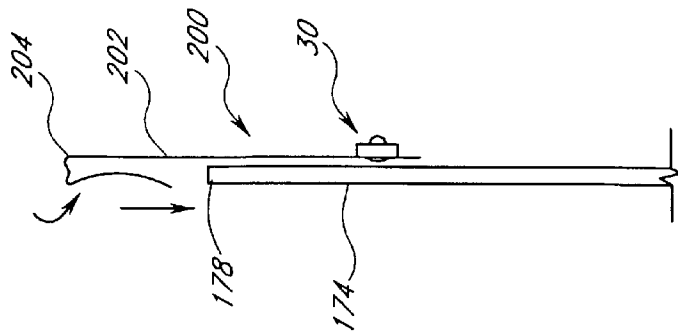

FIG. 26A

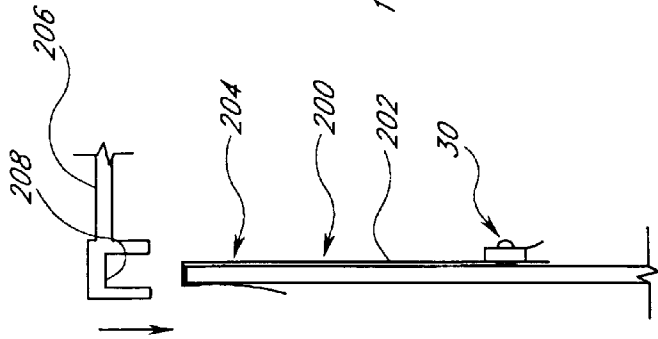

FIG. 26B

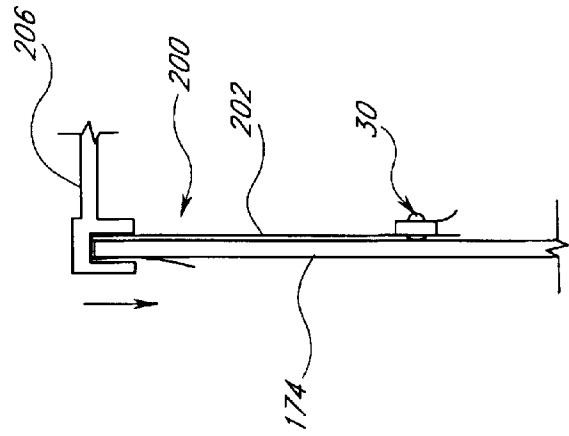

FIG. 26C

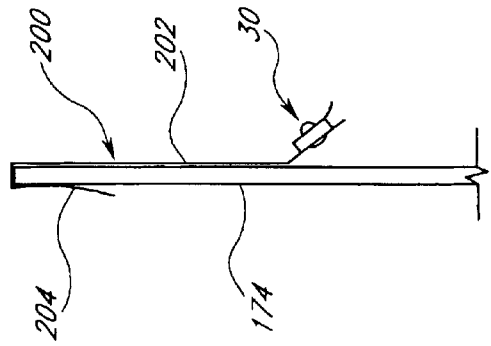

FIG. 26D

## MOUNTING ARRANGEMENT FOR LIGHT EMITTING DIODES

### PRIORITY INFORMATION

This application claims priority to Provisional Patent Application No. 60/160,480, which was filed on Oct. 19, 1999 and No. 60/200,531, which was filed on Apr. 27, 2000.

### BACKGROUND OF THE INVENTION

#### 1. Field of the Invention

The present invention is in the field of light emitting diode (LED) lighting devices and more particularly in the field of an LED lighting module having heat transfer properties that improve the efficiency and performance of LEDs.

#### 2. Description of the Related Art

Light emitting diodes (LEDs) are currently used for a variety of applications. The compactness, efficiency and long life of LEDs is particularly desirable and makes LEDs well suited for many applications. However, a limitation of LEDs' is that they typically cannot maintain a long-term brightness that is acceptable for middle to large-scale illumination applications. Instead, more traditional incandescent or gas-filled light bulbs are often used.

An increase of the electrical current supplied to an LED generally increases the brightness of the light emitted by the LED. However, increased current also increases the juncture temperature of the LED. Increased juncture temperature may reduce the efficiency and the lifetime of the LED. For example, it has been noted that for every 10° C. increase in temperature, silicone and gallium arsenide lifetime drops by a factor of 2.5-3. LEDs are often constructed of semiconductor materials that share many similar properties with silicone and gallium arsenide.

### SUMMARY OF THE INVENTION

Accordingly, there is a need in the art for an LED lighting apparatus having heat removal properties that allow an LED on the apparatus to operate at relatively high current levels without increasing the juncture temperature of the LED beyond desired levels.

In accordance with an aspect of the present invention, an LED module is provided for mounting on a heat conducting surface that is substantially larger than the module. The module comprises a plurality of LED packages and a circuit board. Each LED package has an LED and at least one lead. The circuit board comprises a thin dielectric sheet and a plurality of electrically-conductive contacts on a first side of the dielectric sheet. Each of the contacts is configured to mount a lead of an LED package such that the LEDs are connected in series. A heat conductive plate is disposed on a second side of the dielectric sheet. The plate has a first side which is in thermal communication with the contacts through the dielectric sheet. The first side of the plate has a surface area substantially larger than a contact area between the contacts and the dielectric sheet. The plate has a second side adapted to provide thermal contact with the heat conducting surface. In this manner, heat is transferred from the module to the heat conducting surface.

In accordance with another aspect of the present invention, a modular lighting apparatus is provided for conducting heat away from a light source of the apparatus. The apparatus comprises a plurality of LEDs and a circuit board. The circuit board has a main body and a plurality of electrically conductive contacts. Each of the LEDs electrically communicates with at least one of the contacts in a

manner so that the LEDs are configured in a series array. Each of the LEDs electrically communicates with corresponding contacts at an attachment area defined on each contact. An overall surface of the contact is substantially larger than the attachment area. The plurality of contacts are arranged adjacent a first side of the main body and are in thermal communication with the first side of the main body. The main body electrically insulates the plurality of contacts relative to one another.

For purposes of summarizing the invention and the advantages achieved over the prior art, certain objects and advantages of the invention have been described herein above. Of course, it is to be understood that not necessarily all such objects or advantages may be achieved in accordance with any particular embodiment of the invention. Thus, for example, those skilled in the art will recognize that the invention may be embodied or carried out in a manner that achieves or optimizes one advantage or group of advantages as taught herein without necessarily achieving other objects or advantages as may be taught or suggested herein.

All of these embodiments are intended to be within the scope of the invention herein disclosed. These and other embodiments of the present invention will become readily apparent to those skilled in the art from the following detailed description of the preferred embodiments having reference to the attached figures, the invention not being limited to any particular preferred embodiment(s) disclosed.

### BRIEF DESCRIPTION OF THE DRAWINGS

FIG. 1 is a perspective view of an LED module having features in accordance with the present invention.

FIG. 2 is a schematic side view of a typical pre-packaged LED lamp.

FIG. 3 is a top plan view of the LED module of FIG. 1.

FIG. 4 is a side plan view of the apparatus of FIG. 3.

FIG. 5 is a close-up side view of the apparatus of FIG. 3 mounted on a heat conductive member.

FIG. 6 is another sectional side view of the apparatus of FIG. 3 mounted onto a heat conductive flat surface.

FIG. 7 is a side plan view of an LED module having features in accordance with another embodiment of the present invention.

FIG. 8 is a side plan view of another LED module having features in accordance with yet another embodiment of the present invention.

FIG. 9 is a perspective view of an illumination apparatus having features in accordance with the present invention.

FIG. 10 is a side view of the apparatus of FIG. 9.

FIG. 11 is a bottom view of the apparatus of FIG. 9.

FIG. 12 is a top view of the apparatus of FIG. 9.

FIG. 13 is a schematic view of the apparatus of FIG. 9 mounted on a theater seat row end.

FIG. 14 is a side view of the apparatus of FIG. 13 showing the mounting orientation.

FIG. 15 is a side view of a mounting barb.

FIG. 16 is a front plan view of the illumination apparatus of FIG. 9.

FIG. 17 is a cutaway side plan view of the apparatus of FIG. 20.

FIG. 18 is a schematic plan view of a heat sink base plate.

FIG. 19 is a close-up side sectional view of an LED module mounted on a mount tab of a base plate.

FIG. 20 is a plan view of a lens for use with the apparatus of FIG. 9.

FIG. 21 is a perspective view of a channel illumination apparatus incorporating LED modules having features in accordance with the present invention.

FIG. 22 is a close-up side view of an LED module mounted on a mount tab.

FIG. 23 is a partial view of a wall of the apparatus of FIG. 21, taken along line 23—23.

FIG. 24 is a top view of an LED module mounted to a wall of the apparatus of FIG. 21.

FIG. 25 is a top view of an alternative embodiment of an LED module mounted to a wall of the apparatus of FIG. 21.

FIG. 26A is a side view of an alternative embodiment of a lighting module being mounted onto a channel illumination apparatus wall member.

FIG. 26B shows the apparatus of the arrangement of FIG. 26A with the lighting module installed.

FIG. 26C shows the arrangement of FIG. 26B with a lens installed on the wall member.

FIG. 26D shows a side view of an alternative embodiment of a lighting module installed on a channel illumination apparatus wall member.

#### DETAILED DESCRIPTION OF THE PREFERRED EMBODIMENT

With reference first to FIG. 1, an embodiment of a light-emitting diode (LED) lighting module 30 is disclosed. In the illustrated embodiment, the LED module 30 includes five pre-packaged LEDs 32 arranged on one side of the module 30. It is to be understood, however, that LED modules having features in accordance with the present invention can be constructed having any number of LEDs 32 mounted in any desired configuration.

With next reference to FIG. 2, a typical pre-packaged LED 32 includes a diode chip 34 encased within a resin body 36. The body 36 typically has a focusing lens portion 38. A negative lead 40 connects to an anode side 42 of the diode chip 34 and a positive lead 44 connects to a cathode side 46 of the diode chip 34. The positive lead 44 preferably includes a reflector portion 48 to help direct light from the diode 34 to the lens portion 38.

With next reference to FIGS. 1–5, the LED module 30 preferably comprises the five pre-packaged LED lamps 32 mounted in a linear array on a circuit board 50 and electrically connected in series. The illustrated embodiment employs pre-packaged aluminum indium-gallium phosphide (AlInGaP) LED lamps 32 such as model HLMT-PL00, which is available from Hewlett Packard. In the illustrated embodiment, each of the pre-packaged LEDs is substantially identical so that they emit the same color of light. It is to be understood, however, that nonidentical LEDs may be used to achieve certain desired lighting effects.

The illustrated circuit board 50 preferably is about 0.05 inches thick, 1 inch long and 0.5 inch wide. It includes three layers: a copper contact layer 52, an epoxy dielectric layer 54 and an aluminum main body layer 56. The copper contact layer 52 is made up of a series of six elongate and generally parallel flat copper plates 60 that are adapted to attach to the leads 40, 44 of the LEDs 32. Each of the copper contacts 60 is electrically insulated from the other copper contacts 60 by the dielectric layer 54. Preferably, the copper contacts 60 are substantially coplanar.

The pre-packaged LEDs 32 are attached to one side of the circuit board 50, with the body portion 36 of each LED generally abutting a side of the circuit board 50. The LED lens portion 38 is thus pointed outwardly so as to direct light

in a direction substantially coplanar with the circuit board 50. The LED leads 40, 44 are soldered onto the contacts 60 in order to create a series array of LEDs. Excess material from the leads of the individual pre-packaged LED lamps may be removed, if desired. Each of the contacts 60, except for the first and last contact 62, 64, have both a negative lead 40 and a positive lead 44 attached thereto. One of the first and last contacts 62, 64 has only a negative lead 40 attached thereto; the other has only a positive lead 44 attached thereto.

A bonding area of the contacts accommodates the leads 40, 44, which are preferably bonded to the contact 60 with solder 68; however, each contact 60 preferably has a surface area much larger than is required for adequate bonding in the bonding area 66. The enlarged contact surface area allows each contact 60 to operate as a heat sink, efficiently absorbing heat from the LED leads 40, 44. To maximize this role, the contacts 60 are shaped to be as large as possible while still fitting upon the circuit board 50.

The dielectric layer 54 preferably has strong electrical insulation properties but also relatively high heat conductance properties. In the illustrated embodiment, the layer 54 is preferably as thin as practicable. For example in the illustrated embodiment, the dielectric layer 54 comprises a layer of Thermagon® epoxy about 0.002 inches thick.

It is to be understood that various materials and thicknesses can be used for the dielectric layer 54. Generally, the lower the thermal conductivity of the material used for the dielectric layer, the thinner that dielectric layer should be in order to maximize heat transfer properties of the module. For example, in the illustrated embodiment, the layer of epoxy is very thin. Certain ceramic materials, such as beryllium oxide and aluminum nitride, are electrically non-conductive but highly thermally conductive. When the dielectric layer is constructed of such materials, it is not as crucial for the dielectric layer to be so very thin, because of the high thermal conductivity of the material.

In the illustrated embodiment, the main body 56 makes up the bulk of the thickness of the circuit board 50 and preferably comprises a flat aluminum plate. As with each of the individual contacts 60, the main body 56 functions as a heat conduit, absorbing heat from the contacts 60 through the dielectric layer 54 to conduct heat away from the LEDs 32. However, rather than just absorbing heat from a single LED 32, the main body 56 acts as a common heat conduit, absorbing heat from all of the contacts 60. As such, in the illustrated embodiment, the surface area of the main body 56 is about the same as the combined surface area of all of the individual contacts 60. The main body 56 can be significantly larger than shown in the illustrated embodiment, but its relatively compact shape is preferable in order to increase versatility when mounting the light module 30. Additionally, the main body 56 is relatively rigid and provides structural support for the lighting module 30.

In the illustrated embodiment, aluminum has been chosen for its high thermal conductance properties and ease of manufacture. It is to be understood, however, that any material having advantageous thermal conductance properties, such as having thermal conductivity greater than about 100 watts per meter per Kelvin (W/m-K), would be acceptable.

A pair of holes 70 are preferably formed through the circuit board 50 and are adapted to accommodate a pair of aluminum pop rivets 72. The pop rivets 72 hold the circuit board 50 securely onto a heat conductive mount member 76. The mount member 76 functions as or communicates with a

heat sink. Thus, heat from the LEDs **32** is conducted with relatively little resistance through the module **30** to the attached heat sink **76** so that the junction temperature of the diode chip **34** within the LED **32** does not exceed a maximum desired level.

With reference again to FIGS. **3** and **5**, a power supply wire **78** is attached across the first and last contacts **62**, **64** of the circuit board **50** so that electrical current is provided to the series-connected LEDs **32**. The power supply is preferably a 12-volt system and may be AC, DC or any other suitable power supply. A 12-volt AC system may be fully rectified.

The small size of the LED module **30** provides versatility so that modules can be mounted at various places and in various configurations. For instance, some applications will include only a single module for a particular lighting application, while other lighting applications will employ a plurality of modules electrically connected in parallel relative to each other.

It is also to be understood that any number of LEDs can be included in one module. For example, some modules may use two LEDs, while other modules may use 10 or more LEDs. One manner of determining the number of LEDs to include in a single module is to first determine the desired operating voltage of a single LED of the module and also the voltage of the power supply. The number of LEDs desired for the module is then roughly equal to the voltage of the power supply divided by the operating voltage of each of the LEDs. present invention rapidly conducts heat away from the diode chip **34** of each LED **32** so as to permit the LEDs **32** to be operated in regimes that exceed normal operating parameters of the pre-packaged LEDs **32**. In particular, the heat sinks allow the LED circuit to be driven in a continuous, non-pulsed manner at a higher long-term electrical current than is possible for typical LED mounting configurations. This operating current is substantially greater than manufacturer-recommended maximums. The optical emission of the LEDs at the higher current is also markedly greater than at manufacturer-suggested maximum currents.

The heat transfer arrangement of the LED modules **30** is especially advantageous for pre-packaged LEDs **32** having relatively small packaging and for single-diode LED lamps. For instance, the HLMT-PL00 model LED lamps used in the illustrated embodiment employ only a single diode, but since heat can be drawn efficiently from that single diode through the leads and circuit board and into the heat sink, the diode can be run at a higher current than such LEDs are traditionally operated. At such a current, the single-diode LED shines brighter than LED lamps that employ two or more diodes and which are brighter than a single-diode lamp during traditional operation. Of course, pre-packaged LED lamps having multiple diodes can also be employed with the present invention. It is also to be understood that the relatively small packaging of the model HLMT-PL00 lamps aids in heat transfer by allowing the heat sink to be attached to the leads closer to the diode chip.

With next reference to FIG. **5**, a first reflective layer **80** is preferably attached immediately on top of the contacts **60** of the circuit board **50** and is held in position by the rivets **72**. The first reflector **80** preferably extends outwardly beyond the LEDs **32**. The reflective material preferably comprises an electrically non-conductive film such as visible mirror film available from 3M. A second reflective layer **82** is preferably attached to the mount member **76** at a point immediately adjacent the LED lamps **32**. The second strip **82** is preferably bonded to the mount surface **76** using adhesive in a manner known in the art.

With reference also to FIG. **6**, the first reflective strip **80** is preferably bent so as to form a convex reflective trough about the LEDs **32**. The convex trough is adapted to direct light rays emitted by the LEDs **32** outward with a minimum of reflections between the reflector strips **80**, **82**. Additionally, light from the LEDs is limited to being directed in a specified general direction by the reflecting films **80**, **82**. As also shown in FIG. **6**, the circuit board **50** can be mounted directly to any mount surface **76**.

In another embodiment, the aluminum main body portion **56** may be of reduced thickness or may be formed of a softer metal so that the module **30** can be partially deformed by a user. In this manner, the module **30** can be adjusted to fit onto various surfaces, whether they are flat or curved. By being able to adjust the fit of the module to the surface, the shared contact surface between the main body and the adjacent heat sink is maximized, improving heat transfer properties. Additional embodiments can use fasteners other than rivets to hold the module into place on the mount surface/heat sink material. These additional fasteners can include any known fastening means such as welding, heat conductive adhesives, and the like.

As discussed above, a number of materials may be used for the circuit board portion of the LED module. With specific reference to FIG. **7**, another embodiment of an LED module **86** comprises a series of elongate, flat contacts **88** similar to those described above with reference to FIG. **3**. The contacts **88** are mounted directly onto the main body portion **89**. The main body **89** comprises a rigid, substantially flat ceramic plate. The ceramic plate makes up the bulk of the circuit board and provides structural support for the contacts **88**. Also, the ceramic plate has a surface area about the same as the combined surface area of the contacts. In this manner, the plate is large enough to provide structural support for the contacts **88** and conduct heat away from each of the contacts **88**, but is small enough to allow the module **86** to be relatively small and easy to work with. The ceramic plate **89** is preferably electrically nonconductive but has high heat conductivity. Thus, the contacts **88** are electrically insulated relative to each other, but heat from the contacts **88** is readily transferred to the ceramic plate **89** and into an adjoining heat sink.

With next reference to FIG. **8**, another embodiment of an LED lighting module **90** is shown. The LED module **90** comprises a circuit board **92** having features substantially similar to the circuit board **50** described above with reference to FIG. **3**. The diode portion **94** of the LED **96** is mounted substantially directly onto the contacts **60** of the lighting module **90**. In this manner, any thermal resistance from leads of pre-packaged LEDs is eliminated by transferring heat directly from the diode **94** onto each heat sink contact **60**, from which the heat is conducted to the main body **56** and then out of the module **90**. In this configuration, heat transfer properties are yet further improved.

As discussed above, an LED module having features as described above can be used in many applications such as, for example, indoor and outdoor decorative lighting, commercial lighting, spot lighting, and even room lighting. With next reference to FIGS. **9-12**, a self-contained lighting apparatus **100** incorporates an LED module **30** and can be used in many such applications. In the illustrated embodiment, the lighting apparatus **100** is adapted to be installed on the side of a row of theater seats **102**, as shown in FIG. **13**, and is adapted to illuminate an aisle **104** next to the theater seats **102**.

The self-contained lighting apparatus **100** comprises a base plate **106**, a housing **108**, and an LED module **30**

arranged within the housing **108**. As shown in FIGS. **9**, **10** and **13**, the base plate **106** is preferably substantially circular and has a diameter of about 5.75 inches. The base plate **106** is preferably formed of  $\frac{1}{16}$ " inch thick aluminum sheet. As described in more detail below, the plate functions as a heat sink to absorb and dissipate heat from the LED module. As such, the base plate **106** is preferably formed as large as is practicable, given aesthetic and installation concerns.

As discussed above, the lighting apparatus **100** is especially adapted to be mounted on an end panel **110** of a row of theater chairs **102** in order to illuminate an adjacent aisle **104**. As shown in FIGS. **13** and **14**, the base plate **106** is preferably installed in a vertical orientation. Such vertical orientation aids conductive heat transfer from the base plate **106** to the environment.

The base plate **106** includes three holes **112** adapted to facilitate mounting. A ratcheting barb **116** (see FIG. **15**) secures the plate **106** to the panel **110**. The barb **116** has an elongate main body **118** having a plurality of biased ribs **120** and terminating at a domed top **122**.

To mount the apparatus on the end panel **110**, a hole is first formed in the end panel surface on which the apparatus is to be mounted. The base plate holes **112** are aligned with mount surface holes and the barbs **116** are inserted through the base plate **106** into the holes. The ribs **120** prevent the barbs **116** from being drawn out of the holes once inserted. Thus, the apparatus is securely held in place and cannot be easily removed. The barbs **116** are especially advantageous because they enable the device to be mounted on various surfaces. For example, the barbs will securely mount the illumination apparatus on wooden or fabric surfaces.

With reference next to FIGS. **16**–**19**, a mount tab **130** is provided as an integral part of the base plate **106**. The mounting tab **130** is adapted to receive an LED module **30** mounted thereon. The tab **30** is preferably plastically deformed along a hinge line **132** to an angle  $\theta$  between about 20–45° relative to the main body **134** of the base plate **106**. More preferably, the mounting tab **130** is bent at an angle  $\theta$  of about 33°. The inclusion of the tab **130** as an integral part of the base plate **106** facilitates heat transfer from the tab **130** to the main body **134** of the base plate. It is to be understood that the angle  $\theta$  of the tab **130** relative to the base plate body **134** can be any desired angle as appropriate for the particular application of the lighting apparatus **100**.

A cut out portion **136** of the base plate **106** is provided surrounding the mount tab **130**. The cut out portion **136** provides space for components of the mount tab **130** to fit onto the base plate **106**. Also, the cut out portion **136** helps define the shape of the mount tab **130**. As discussed above, the mount tab **130** is preferably plastically deformed along the hinge line **132**. The length of the hinge line **132** is determined by the shape of the cut out portion **136** in that area. Also, a hole **138** is preferably formed in the hinge line **132**. The hole **138** further facilitates plastic deformation along the hinge line **132**.

Power for the light source assembly **100** is preferably provided through a power cord **78** that enters the apparatus **100** through a back side of the base plate **106**. The cord **78** preferably includes two 18 AWG conductors surrounded by an insulating sheet. Preferably, the power supply is in the low voltage range. For example, the power supply is preferably a 12-volt alternating current power source. As depicted in FIG. **18**, power is preferably first provided through a full wave ridge rectifier **140** which rectifies the alternating current in a manner known in the art so that substantially all of the current range can be used by the LED

module **40**. In the illustrated embodiment, the LEDs are preferably not electrically connected to a current-limiting resistor. Thus, maximum light output can be achieved. It is to be understood, however, that resistors may be desirable in some embodiments to regulate current. Supply wires **142** extend from the rectifier **140** and provide rectified power to the LED module **30** mounted on the mounting tab **130**.

With reference again to FIGS. **9**–**12**, **16** and **17**, the housing **108** is positioned on the base plate **106** and preferably encloses the wiring connections in the light source assembly **100**. The housing **108** is preferably substantially semi-spherical in shape and has a notch **144** formed on the bottom side. A cavity **146** is formed through the notch **144** and allows visual access to the light source assembly **100**. A second cavity **148** is formed on the top side and preferably includes a plug **150** which may, if desired, include a marking such as a row number. In an additional embodiment, a portion of the light from the LED module **30**, or even from an alternative light source, may provide light to light up the aisle marker.

The housing **108** is preferably secured to the base plate **106** by a pair of screws **152**. Preferably, the screws **152** extend through countersunk holes **154** in the base plate **106**. This enables the base plate **106** to be substantially flat on the back side, allowing the plate to be mounted flush with the mount surface. As shown in FIG. **17**, threaded screw receiver posts **156** are formed within the housing **108** and are adapted to accommodate the screw threads.

The LED module **30** is attached to the mount tab **130** by the pop rivets **72**. The module **30** and rivets **72** conduct heat from the LEDs **32** to the mount tab **130**. Since the tab **130** is integrally formed as a part of the base plate **106**, heat flows freely from the tab **130** to the main body **134** of the base plate. The base plate **106** has high heat conductance properties and a relatively large surface area, thus facilitating efficient heat transfer to the environment and allowing the base plate **106** to function as a heat sink.

As discussed above, the first reflective strip **80** of the LED module **30** is preferably bent so as to form a convex trough about the LEDs. The second reflector strip **82** is attached to the base plate mount tab **130** at a point immediately adjacent the LED lamps **32**. Thus, light from the LEDs is collimated and directed out of the bottom cavity **146** of the housing **108**, while minimizing the number of reflections the light must make between the reflectors (see FIG. **6**). Such reflections may each reduce the intensity of light reflected.

A lens or shield **160** is provided and is adapted to be positioned between the LEDs **32** and the environment outside of the housing cavity **108**. The shield **160** prevents direct access to the LEDs **32** and thus prevents harm that may occur from vandalism or the like, but also transmits light emitted by the light source **100**.

FIG. **20** shows an embodiment of the shield **160** adapted for use in the present invention. As shown, the shield **160** is substantially lenticularly shaped and has a notch **162** formed on either end thereof. With reference back to FIG. **18**, the mounting tab **130** of the base plate **106** also has a pair of notches **164** formed therein.

As shown in FIG. **16**, the lens/shield notches **162** are adapted to fit within the tab notches **164** so that the shield **160** is held in place in a substantially arcuate position. The shield thus, in effect, wraps around one side of the LEDs **32**. When the shield **160** is wrapped around the LEDs **32**, the shield **160** contacts the first reflector film **80**, deflecting the film **80** to further form the film in a convex arrangement. The shield **160** is preferably formed of a clear polycarbonate

material, but it is to be understood that the shield **160** may be formed of any clear or colored transmissive material as desired by the user.

The LED module **30** of the present invention can also be used in applications using a plurality of such modules **30** to appropriately light a lighting apparatus such as a channel illumination device. Channel illumination devices are frequently used for signage including borders and lettering. In these devices, a wall structure outlines a desired shape to be illuminated, with one or more channels defined between the walls. A light source is mounted within the channel and a translucent diffusing lens is usually arranged at the top edges of the walls so as to enclose the channel. In this manner, a desired shape can be illuminated in a desired color as defined by the color of the lens.

Typically, a gas-containing light source such as a neon light is custom-shaped to fit within the channel. Although the diffusing lens is placed over the light source, the light apparatus may still produce "hot spots," which are portions of the sign that are visibly brighter than other portions of the sign. Such hot spots result because the lighting apparatus shines directly at the lens, and the lens may have limited light-diffusing capability. Incandescent lamps may also be used to illuminate such a channel illumination apparatus; however, the hot spot problem typically is even more pronounced with incandescent lights.

Both incandescent and gas-filled lights have relatively high manufacturing and operation costs. For instance, gas-filled lights typically require custom shaping and installation and therefore can be very expensive to manufacture. Additionally, both incandescent and gas-filled lights have high power requirements.

With reference next to FIG. **21**, an embodiment of a channel illumination apparatus **170** is disclosed comprising a casing **172** in the shape of a "P." The casing **172** includes a plurality of walls **174** and a bottom **176**, which together define at least one channel. The surfaces of the walls **174** and bottom **176** are diffusely-reflective, preferably being coated with a flat white coating. The walls **174** are preferably formed of a durable sturdy metal having relatively high heat conductivity. A plurality of LED lighting modules **30** are mounted to the walls **174** of the casing **172** in a spaced-apart manner. A translucent light-diffusing lens (not shown) is preferably disposed on a top edge **178** of the walls **174** and encloses the channel.

With next reference to FIG. **22**, the pop rivets **72** hold the LED module **30** securely onto a heat conductive mount tab **180**. The mount tab **180**, in turn, may be connected, by rivets **182** or any other fastening means, to the walls **174** of the channel apparatus as shown in FIG. **23**. Preferably, the connection of the mount tab **180** to the walls **174** facilitates heat transfer from the tab **180** to the wall **174**. The channel wall has a relatively large surface area, facilitating efficient heat transfer to the environment and enabling the channel wall **174** to function as a heat sink.

In additional embodiments, the casing **172** may be constructed of materials, such as certain plastics, that may not be capable of functioning as heat sinks because of inferior heat conductance properties. In such embodiments, the LED module **30** can be connected to its own relatively large heat sink base plate, which is mounted to the wall of the casing. An example of such a heat sink plate in conjunction with an LED lighting module has been disclosed above with reference to the self-contained lighting apparatus **100**.

With continued reference to FIGS. **22** and **23**, the LED modules **30** are preferably electrically connected in parallel

relative to other modules **30** in the illumination apparatus **170**. A power supply cord **184** preferably enters through a wall **174** or bottom surface **176** of the casing **172** and preferably comprises two 18 AWG main conductors **186**. Short wires **188** are attached to the first and last contacts **62**, **64** of each module **30** and preferably connect with respective main conductors **186** using insulation displacement connectors (IDCs) **190** as shown in FIG. **23**.

Although the LEDs **32** in the modules **30** are operated at currents higher than typical LEDs, the power efficiency characteristic of LEDs is retained. For example, a typical channel light employing a neon-filled light could be expected to use about 60 watts of power during operation. A corresponding channel illumination apparatus **170** using a plurality of LED modules can be expected to use about 4.5 watts of power.

With reference again to FIG. **23**, the LED modules **30** are preferably positioned so that the LEDs **32** face generally downwardly, directing light away from the lens. The light is preferably directed to the diffusely-reflective wall and bottom surfaces **174**, **176** of the casing **172**. The hot spots associated with more direct forms of lighting, such as typical incandescent and gas-filled bulb arrangements, are thus avoided.

The reflectors **80**, **82** of the LED modules **30** aid in directing light rays emanating from the LEDs toward the diffusely-reflective surfaces. It is to be understood, however, that an LED module **30** not employing reflectors can also be appropriately used.

The relatively low profile of each LED module **30** facilitates the indirect method of lighting because substantially no shadow is created by the module when it is positioned on the wall **174**. A higher-profile light module would cast a shadow on the lens, producing an undesirable, visibly darkened area. To minimize the potential of shadowing, it is desired to space the modules **30** and accompanying power wires **186**, **188** a distance of at least about 2 inch from the top edge **178** of the wall **174**. More preferably, the modules **30** are spaced more than one inch from the top **178** of the wall **174**.

The small size and low profile of the LED modules **30** enables the modules to be mounted at various places along the channel wall **174**. For instance, with reference to FIGS. **21** and **24**, light modules **30** must sometimes be mounted to curving portions **192** of walls **174**. The modules **30** are preferably about 1 inch to 1½ inch long, including the mounting tab **180**, and thus can be acceptably mounted to a curving wall **192**. As shown, the mounting tab **180** may be separated from the curving wall **192** along a portion of its length, but the module is small enough that it is suitable for riveting to the wall.

In an additional embodiment shown in FIG. **25**, the module **30** comprises the circuit board without the mount tab **180**. In such an embodiment, the circuit board **50** may be mounted directly to the wall, having an even better fit relative to the curved surface **192** than the embodiment using a mount tab. In still another embodiment, the LED module's main body **56** is formed of a bendable material, which allows the module to fit more closely and easily to the curved wall surface.

Although the LED modules **30** disclosed above are mounted to the channel casing wall **174** with rivets **182**, it is to be understood that any method of mounting may be acceptably used. With reference next to FIGS. **26A-C**, an additional embodiment comprises an LED module **30** mounted to a mounting tab **200** which comprises an elongate body portion **202** and a clip portion **204**. The clip portion

204 is urged over the top edge 178 of the casing wall 172, firmly holding the mounting tab 200 to the wall 174 as shown in Figure, 26B. The lens 206 preferably has a channel portion 208 which is adapted to engage the top edge 178 of the casing wall 174 and can be fit over the clip portion 204 of the mount tab 200 as shown in FIGS. 26B and 26C. This mounting arrangement is simple and provides ample surface area contact between the casing wall 174 and the mounting tab 200 so that heat transfer is facilitated.

In the embodiment shown in FIG. 21, the casing walls 174 are about 3 to 4 inches deep and the width of the channel is about 3 to 4 inches between the walls. In an apparatus of this size, LED modules 30 positioned on one side of the channel can provide sufficient lighting. The modules are preferably spaced about 5–6 inches apart. As may be anticipated, larger channel apparatus will likely require somewhat different arrangements of LED modules, including employing more LED modules. For example, a channel illumination apparatus having a channel width of 1 to 2 feet may employ LED modules on both walls and may even use multiple rows of LED modules. Additionally, the orientation of each of the modules may be varied in such a large channel illumination apparatus. For instance, with reference to FIG. 26D, some of the LED modules may desirably be angled so as to direct light at various angles relative to the diffusely reflective surfaces.

In order to avoid creating hot spots, a direct light path from the LED 32 to the lens 206 is preferably avoided. However, it is to be understood that pre-packaged LED lamps 32 having diffusely-reflective lenses may advantageously be directed toward the channel letter lens 206.

Using LED modules 30 to illuminate a channel illumination apparatus 170 provides significant savings during manufacturing. For example, a number of LED modules, along with appropriate wiring and hardware, can be included in a kit which allows a technician to easily assemble a light by simply securing the modules in place along the wall of the casing and connecting the wiring appropriately using the IDCs. Although rivet holes may have to be drilled through the wall, there is no need for custom shaping, as is required with gas-filled bulbs. Accordingly, manufacturing effort and costs are significantly reduced.

Individual LEDs emit generally monochromatic light. Thus, it is preferable that an LED type be chosen which corresponds to the desired illumination color. Additionally, the diffuser is preferably chosen to be substantially the same color as the LEDs. Such an arrangement facilitates desirable brightness and color results. It is also to be understood that the diffusely-reflective wall and bottom surfaces may advantageously be coated to match the desired illumination color.

Although this invention has been disclosed in the context of certain preferred embodiments and examples, it will be understood by those skilled in the art that the present invention extends beyond the specifically-disclosed embodiments to other alternative embodiments and/or uses of the invention and obvious modifications and equivalents thereof. In addition, while a number of variations of the invention have been shown and described in detail, other modifications, which are within the scope of this invention, will be readily apparent to those of skill in the art based upon this disclosure. It is also contemplated that various combinations or subcombinations of the specific features and aspects of the embodiments may be made and still fall within the scope of the invention. Accordingly, it should be understood that various features and aspects of the disclosed embodiments can be combined with or substituted for one

another in order to form varying modes of the disclosed invention. Thus, it is intended that the scope of the present invention herein disclosed should not be limited by the particular disclosed embodiments described above, but should be determined only by a fair reading of the claims that follow.

What is claimed is:

1. A light emitting diode (LED) module for mounting on a heat conducting surface that is substantially larger than the module, the module comprising:

a plurality of LEDs, each LED having at least one lead; and

a circuit board, the circuit board comprising:

a thin dielectric sheet;

a plurality of electrically-conductive contacts on a first side of the dielectric sheet, each of said plurality of contacts being configured to mount a lead of an LED such that said plurality of LEDs is electrically connected; and

a heat conductive body on a second side of said sheet, said body having a first portion in thermal communication with the plurality of contacts through said dielectric sheet, said first portion of said body having a surface area substantially larger than a contact area between the contacts and the dielectric sheet, said body having a second portion adapted to provide thermal contact with the heat conducting surface, the second portion having a surface generally complementary to the heat conducting surface, whereby heat is transferred from the module to the heat conducting surface.

2. The LED module of claim 1, wherein the contacts are substantially flat and coplanar relative to each other.

3. The LED module of claim 2, wherein the plate is substantially flat and parallel to the contacts.

4. The LED module of claim 1, wherein each of the contacts has a portion disposed generally adjacent an edge of the circuit board.

5. The LED module of claim 4, wherein the plurality of LEDs are disposed adjacent one edge of the circuit board.

6. The LED module of claim 5, wherein the LEDs additionally comprise lenses for directing light from the LED in a desired direction, and the LEDs are arranged so that light from the LEDs is directed generally parallel to the circuit board.

7. The LED module of claim 1, wherein the number of contacts is greater than the number of LEDs.

8. The LED module of claim 7, wherein the number of contacts is one greater than the number of LEDs.

9. The LED module of claim 1, wherein the surface area of the first side of the body is greater than a combined surface area of one side of all of the contacts.

10. The LED module of claim 1, wherein each of the contacts has a bonding area wherein at least one of the leads of an associated LED is attached to the contact.

11. The LED module of claim 10, wherein an overall surface of each contact is substantially larger than the bonding area of the contact.

12. The LED module of claim 1, wherein the heat conducting surface behaves as a heat sink.

13. The LED module of claim 1, wherein the dielectric layer comprises an epoxy.

14. The LED module of claim 1, wherein the body is bendable.

15. The LED module of claim 1, wherein the body has a thermal conductivity greater than about 100 W/mK.

16. The LED module of claim 15, wherein the body comprises a metal.

13

17. The LED module of claim 16, wherein the body comprises aluminum.

18. The LED module of claim 15, wherein the body is electrically non-conductive.

19. The LED module of claim 1, additionally comprising an electrically non-conductive flexible film disposed adjacent the contacts on a side of the contacts opposite the body.

20. The LED module of claim 19, wherein the film comprises reflective film, and the reflective film extends outwardly from the module beyond the LEDs.

21. The LED module of claim 20, wherein the film is attached to the module with at least one rivet.

22. The LED module of claim 20 in combination with a second strip of reflective film that is attached to the heat conducting surface adjacent an edge of the circuit board, and the plurality of LEDs is disposed adjacent the edge of the circuit board so that the LEDs are positioned between the first reflective film and the second reflective film.

23. The LED module of claim 1, wherein the module comprises five pre-packaged, pre-focused LED lamps and six contacts, and the LED lamps are disposed adjacent an edge of the circuit board.

24. The LED module of claim 23, wherein the module is about 0.05 inches thick, 1 inch long, and 0.5 inches wide.

25. A self-contained illumination apparatus comprising an LED module in combination with a heat conductive base plate having a mount tab, the LED module being mounted onto the mount tab, the module comprising:

a plurality of LEDs, each LED having at least one lead; and

a circuit board, the circuit board comprising:

a thin dielectric sheet;

a plurality of electrically-conductive contacts on a first side of the dielectric sheet, each of said plurality of contacts being configured to mount a lead of an LED such that said plurality of LEDs is electrically connected; and

a heat conductive body on a second side of said sheet, said body having a first portion in thermal communication with the plurality of contacts through said dielectric sheet, said first portion of said body having a surface area substantially larger than a contact area between the contacts and the dielectric sheet, said body having a second portion adapted to provide thermal contact with the heat conducting surface, whereby heat is transferred from the module to the heat conducting surface.

26. The self-contained illumination apparatus of claim 25, wherein the LED module is mounted onto the mount tab with at least one rivet.

27. The self-contained illumination apparatus of claim 25, wherein the base plate behaves as a heat sink.

28. The self-contained illumination apparatus of claim 25 additionally comprising a housing substantially surrounding the LED module, the housing having a cavity, and the LED module positioned to direct light out of the cavity.

29. The self-contained illumination apparatus of claim 25, wherein the apparatus is mounted on a substantially vertical mount surface.

30. The self-contained illumination apparatus of claim 29, wherein the mount surface comprises an end surface of a row of seats.

31. A channel illumination device comprising a plurality of the LED modules in combination with at least one channel defined by a plurality of wall surfaces and a back surface, wherein the LED modules are mounted on at least one of the surfaces of the channel illumination device, and wherein each LED module comprises:

a plurality of LEDs, each LED having at least one lead; and

14

a circuit board, the circuit board comprising:

a thin dielectric sheet;

a plurality of electrically-conductive contacts on a first side of the dielectric sheet, each of said plurality of contacts being configured to mount a lead of an LED such that said plurality of LEDs is electrically connected; and

a heat conductive body on a second side of said sheet, said body having a first portion in thermal communication with the plurality of contacts through said dielectric sheet, said first portion of said body having a surface area substantially larger than a contact area between the contacts and the dielectric sheet, said body having a second portion adapted to provide thermal contact with the heat conducting surface, whereby heat is transferred from the module to the heat conducting surface.

32. The channel illumination device of claim 31, wherein the plurality of LED modules are electrically connected in parallel relative to each other.

33. The channel illumination device of claim 32, wherein the LED modules are spaced at least about 1/2 inch from a top surface of the walls.

34. The channel illumination device of claim 32, wherein the wall and back surfaces are coated with a diffusely-reflective coating.

35. The channel illumination device of claim 32, wherein the modules are arranged to direct substantially all of the light emitted by the LEDs toward the wall and back surfaces.

36. The channel illumination device of claim 35, wherein the wall and back surfaces are coated with a diffusely-reflective coating.

37. The channel illumination device of claim 31, wherein the at least one channel surface comprises a heat conducting surface.

38. A low profile modular lighting apparatus for conducting heat away from a light source of the apparatus and to a mounting surface, the apparatus comprising:

a plurality of light emitting diodes (LEDs); and

a circuit board comprising a thermally conductive main body and a plurality of electrically conductive contacts, each of the LEDs electrically communicating with at least one of the contacts in a manner so that the LEDs are configured in a series array;

wherein the plurality of contacts are arranged adjacent a first side of the main body and are in thermal communication with the first side of the main body, the main body electrically insulating the plurality of contacts relative to one another; and

wherein the circuit board is generally planar and a second side of the main body opposite the first side is generally flat to facilitate heat transfer from the main body to the mounting surface and so that the apparatus has a low profile upon the mounting surface.

39. The modular lighting apparatus of claim 38, wherein the main body is electrically nonconductive.

40. The modular lighting apparatus of claim 38, wherein the main body is electrically insulated from the contacts.

41. The modular lighting apparatus of claim 40, wherein the main body is metallic.

42. The modular lighting apparatus of claim 38, wherein the main body has a thermal conductivity greater than about 100 W/mK.

43. The modular lighting apparatus of claim 42, wherein the contacts have a thermal conductivity greater than about 100 W/mK.

44. The LED module of claim 1, wherein the LEDs are configured to direct light in a direction generally coplanar with the circuit board.

45. The LED module of claim 44, wherein the LEDs are arranged along a side edge of the circuit board.

46. The LED module of claim 45, comprising LED packages that generally about the side edge of the circuit board.

47. The apparatus of claim 38, wherein each of the LEDs electrically communicates with corresponding contacts at an attachment area defined on each contact, and an overall surface of the contact is substantially larger than the attachment area.

48. A lighting apparatus, comprising:

a light emitting diode (LED) module mounted on a heat conductive base plate;

the LED module comprising:

a plurality of LED packages, each package comprising an LED and at least one lead; and

a circuit board, comprising a thin dielectric sheet, and a plurality of electrically-conductive contacts on a first side of the dielectric sheet, each of the plurality of contacts being configured to mount a lead of an LED package such that the plurality of LEDs is series connected;

the heat conductive base plate being configured to be mounted on a generally vertical surface and comprising a mount tab;

a housing disposed on the base plate and having a generally downwardly directed opening;

wherein the LED module is attached to the mount tab so that the dielectric sheet is disposed between the mount tab and the plurality of contacts, and the mount tab is in thermal communication with the plurality of contacts through the dielectric sheet, whereby heat is transferred from the LED module to the heat conductive base plate, and the base plate is sized and adapted to behave as a heat sink for the heat transferred thereto from the LED module; and wherein the LED module is arranged so that the LEDs direct light through the generally downwardly directed opening through the housing.

49. The lighting apparatus of claim 48, wherein the LEDs are arranged to direct light generally in a direction coplanar to the mount tab.

50. The lighting apparatus of claim 49, wherein the LED packages generally about a side edge of the mount tab.

51. The lighting apparatus of claim 50, wherein the mount tab is angled about 20–45° relative to a body of the base plate.

52. The lighting apparatus of claim 51, wherein the mount tab is angled about 33° relative to the body of the base plate.

53. The lighting apparatus of claim 48, wherein the LED module comprises a thermally-conductive base member attached to a second side of the dielectric sheet, and the base member is directly attached to the mount tab.

54. An illuminated signage system, comprising:

at least one channel defined by a plurality of wall surfaces and a back surface;

a translucent material extending over the channel; and

a plurality of light emitting diode (LED) modules disposed within the channel and arranged on at least one of the channel surfaces; the LED modules being electrically connected to one another in parallel, each of the LED modules comprising:

a plurality of LEDs, each LED having at least one lead; and

a circuit board, comprising a thin dielectric portion, and a plurality of electrically-conductive contacts on a side of the dielectric portion, each of the plurality of contacts being configured to mount a lead of an LED such that the plurality of LEDs are electrically connected;

wherein the LED modules that are attached to the at least one channel surface are mounted so that the dielectric portion is disposed between the channel surface and the plurality of contacts, and the channel surface is in thermal communication with the plurality of contacts through the dielectric portion so that heat is transferred from the LED module to the channel surface.

55. The signage system of claim 54, wherein each of the LED modules additionally comprise a thermally conductive base member connected to a second side of the dielectric portion, the base member comprising a generally flat mounting surface configured to be connected to the channel surface.

56. The signage system of claim 54, wherein each of the plurality of LED modules additionally comprises a reflective layer disposed atop the module so that the module is configured to direct light from the LED in a direction generally coplanar to the contacts.

57. The signage system of claim 56, wherein the LED modules are arranged so that light from the LEDs is directed toward the wall surfaces and bottom surface.

58. The signage system of claim 57, wherein the wall surface and bottom surface are coated with a diffusely-reflective coating.

59. An illuminated signage system, comprising:

at least one channel defined by a plurality of walls, a back surface, and a front, at least a first one of the walls being thermally conductive, the front comprising a translucent material;

at least one lighting module comprising a plurality of light emitting diodes (LEDs) arranged in series on a thermally conductive base;

wherein the at least one module is mounted on the thermally conductive first wall and arranged so that the LEDs do not directly illuminate the translucent front of the channel, and so that heat from the LEDs flows from the module to the thermally conductive first wall.

60. The signage system of claim 59, wherein the at least one module comprises a plurality of LED packages and a circuit board, each package comprising an LED and at least one lead, the circuit board comprising a thin dielectric sheet and a plurality of electrically-conductive contacts disposed on a first side of the dielectric sheet, each of the contacts being configured to mount a lead of an LED package such that the plurality of LEDs is series connected.

61. The signage system of claim 60, wherein the circuit board is generally planar and comprises a generally flat mounting surface so that the module has a low profile when mounted on the first wall.

62. The signage system of claim 60, comprising a plurality of modules arranged along the thermally conductive first wall so that the LEDs do not directly illuminate the translucent front.

63. The signage system of claim 62, wherein the plurality of modules are arranged electrically in parallel relative to one another.

UNITED STATES PATENT AND TRADEMARK OFFICE  
**CERTIFICATE OF CORRECTION**

PATENT NO. : 6,712,486 B1  
DATED : March 30, 2004  
INVENTOR(S) : John Popovich et al.

Page 1 of 3

It is certified that error appears in the above-identified patent and that said Letters Patent is hereby corrected as shown below:

Title page,

Item [56], **References Cited**, U.S. PATENT DOCUMENTS, add the following references:

3,936,686	02/1976	Moore	313/36
4,591,954	05/1986	Kawamura, et al.	
4,720,773	01/1988	Ahroni	362/249
4,761,720	08/1988	Solow	
5,103,382	04/1992	Kondo, et al.	
5,499,170	03/1996	Gagne	
5,607,227	03/1997	Yasumoto, et al.	
5,660,461	08/1997	Ignatius, et al.	
5,697,175	12/1997	Schwartz	40/552
6,042,248	03/2000	Hannah, et al.	
6,045,240	04/2000	Hochstein	362/294
6,396,466	05/2002	Pross, et al.	345/82
6,505,956	01/2003	Priddy et al.	
6,566,824	05/2003	Panagotacos, et al.	
6,578,986	06/2003	Swaris, et al.	
6,582,103	06/2003	Popovich, et al.	
2001/0015891	08/2001	Suzuki, et al.	362/31

Column 16,

Line 64, the following claims are added:

64. A light emitting diode (LED) module for mounting on a heat conducting surface that is substantially larger than the module, the module comprising:  
a plurality of LEDs;  
a thin dielectric portion;  
a plurality of electrically-conductive contacts on a first side of the dielectric portion, each of said plurality of contacts being configured to mount an LED such that said plurality of LEDs are electrically connected to one another; and  
a heat conductive body on a second side of said portion, said body having a first side in thermal communication with the plurality of contacts through said dielectric portion, said first side of said body having a surface area substantially larger than a contact area between the contacts and the dielectric portion, a second side of said body having a surface complementary to the heat conducting surface to provide thermal contact with the heat conducting surface, whereby heat is transferred from the LEDs to the heat conducting surface.
65. An LED module as in Claim 64, wherein the surface of the second side of the body is generally flat.
66. An LED module as in Claim 65, wherein the contacts are substantially flat and coplanar relative to each other.
67. An LED module as in Claim 66, wherein the body is substantially flat and parallel to the contacts.

UNITED STATES PATENT AND TRADEMARK OFFICE  
**CERTIFICATE OF CORRECTION**

PATENT NO. : 6,712,486 B1  
DATED : March 30, 2004  
INVENTOR(S) : John Popovich et al.

Page 2 of 3

It is certified that error appears in the above-identified patent and that said Letters Patent is hereby corrected as shown below:

Column 16 (cont'd).

68. An LED module as in Claim 64, wherein the heat conducting surface behaves as a heat sink.
69. An LED module as in Claim 64, wherein the dielectric portion comprises an epoxy.
70. An LED module as in Claim 64, wherein the body has a thermal conductivity greater than about 100 W/mK.
71. An LED module as in Claim 70, wherein the body comprises a metal.
72. An LED module as in Claim 71, wherein the body comprises aluminum.
73. A channel illumination device comprising a plurality of the LED modules of Claim 64 in combination with at least one channel defined by a plurality of wall surfaces and a back surface, wherein the LED modules are mounted on at least one of the surfaces of the channel illumination device.
74. A channel illumination device as in Claim 73, wherein the plurality of LED modules are electrically connected in parallel relative to each other.
75. A channel illumination device as in Claim 73, wherein the at least one channel surface comprises a heat conducting surface.
- 
76. An illuminated sign, comprising:  
a body of thermally conductive material having a thermal conductivity greater than about 100W/mK, said body having a periphery in the shape of an element of said sign; and  
a plurality of light emitting diode (LED) modules disposed on an interior side of said body, the LED modules being electrically connected to one another in parallel, each of the LED modules comprising:  
a plurality of LEDs;  
a thin dielectric member; and  
a plurality of electrically-conductive contacts on a side of the dielectric member, each of the plurality of contacts being configured to mount an LED such that the plurality of LEDs are electrically connected;  
wherein each of the LED modules that are attached to the body are mounted so that the dielectric member is disposed between the body and the plurality of contacts, and the body is in thermal communication with the plurality of contacts through the dielectric member so that heat is transferred from the LED module to the body.
77. An illuminated sign as in Claim 76, wherein the dielectric member is substantially planar.
78. An illuminated sign as in Claim 77, wherein the contacts are substantially flat and coplanar relative to each other.
79. An illuminated sign as in Claim 76 additionally comprising a thermally conductive member on a second side of the dielectric member.
80. An illuminated sign as in Claim 79, wherein the thermally conductive member has a thermal conductivity greater than about 100 W/mK.
81. An illuminated sign as in Claim 80, wherein the thermally conductive member is substantially rigid.
- 
82. An illuminated signage system, comprising:  
at least one channel defined by a plurality of wall surfaces and a back surface; and  
a plurality of light emitting diode (LED) modules disposed within the channel and arranged on at least one of the channel surfaces, the LED modules being electrically connected to one another in parallel, each of the LED modules comprising:  
a plurality of LEDs, each LED having at least one lead; and  
a circuit board, comprising a thin dielectric portion, and a plurality of electrically-conductive contacts on a side of the dielectric portion, the plurality of contacts being configured to mount respective leads of an LED such that the plurality of LEDs are electrically connected;  
wherein the LED modules that are attached to the at least one channel surface are mounted so that the channel surface is in thermal communication with the plurality of contacts so that heat is transferred from the LED module to the channel surface.

UNITED STATES PATENT AND TRADEMARK OFFICE  
**CERTIFICATE OF CORRECTION**

PATENT NO. : 6,712,486 B1  
DATED : March 30, 2004  
INVENTOR(S) : John Popovich et al.

Page 3 of 3

It is certified that error appears in the above-identified patent and that said Letters Patent is hereby corrected as shown below:

Column 16 (cont'd).

83. The illuminated signage system of Claim 82 additionally comprising a translucent material extending over the channel.
84. The illuminated signage system of Claim 82, wherein the dielectric portion is disposed between the channel surface and the plurality of contacts.
85. The illuminated signage system of Claim 82, wherein the circuit board comprises a generally flat surface generally complementary to a channel surface.
86. The illuminated signage system of Claim 82, wherein the circuit board is bendable.
- 
87. An illuminated signage system, comprising:  
at least one channel defined by a plurality of wall surfaces and a back surface; and  
a plurality of light emitting diode (LED) modules disposed within the channel and attached to at least one of the channel surfaces, the LED modules being electrically connected to one another in parallel, each of the LED modules comprising:  
a plurality of LEDs;  
a circuit board comprising a dielectric portion, the LEDs disposed on a first side of the dielectric portion and arranged such that the plurality of LEDs are electrically connected in series; and  
a heat conductive metal on a second side of the dielectric portion, which heat conductive metal draws LED-generated heat from the first side for dissipation in the channel.
88. The illuminated signage system of Claim 87, wherein the circuit board is interposed between the LEDs and the channel surface.
89. The illuminated signage system of Claim 87, wherein a translucent diffuser extends over the channel.
- 

Signed and Sealed this

Seventeenth Day of August, 2004

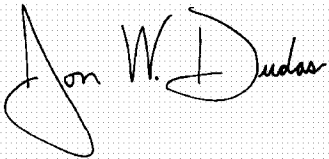

JON W. DUDAS

*Acting Director of the United States Patent and Trademark Office*