



US006585395B2

(12) **United States Patent**  
**Luk**

(10) **Patent No.:** **US 6,585,395 B2**  
(45) **Date of Patent:** **Jul. 1, 2003**

(54) **VARIABLE BEAM LIGHT EMITTING DIODE LIGHT SOURCE SYSTEM**

5,920,643 A \* 7/1999 White et al. .... 362/249  
6,390,643 B1 \* 5/2002 Knight ..... 362/231

(75) Inventor: **John F. Luk**, Flushing, NY (US)

\* cited by examiner

(73) Assignee: **Altman Stage Lighting Co., Inc.**,  
Yonkers, NY (US)

*Primary Examiner*—Sandra O’Shea  
*Assistant Examiner*—Ismael Negron

(74) *Attorney, Agent, or Firm*—Lackebach & Siegel LLP

(\*) Notice: Subject to any disclaimer, the term of this patent is extended or adjusted under 35 U.S.C. 154(b) by 22 days.

(57) **ABSTRACT**

A light source for stage, theatrical and architectural lighting that includes a plurality of separate flat and rigid panels for mounting a plurality of light emitting diodes that emit light beams to a common focus area, each separate panel having grouped diodes of the plurality of diodes, and having inner and outer panel portions. A housing has a center base portion and an aperture/plane rim transverse to an axis aligned with the center base portion. A first connection flexibly secures each outer panel portion to the rim. A screw positions the panels at selected positions wherein each is oriented at a selected angle relative to the axis and the diodes emit light beams transverse to each separate panel. A second connection flexibly secures each inner panel portion to the screw. The panels hold the diodes and include circuit boards for powering the diodes. The screw is elongated and rotatably aligned with the axis of and threaded to a nut at its outer end portion, and its inner end portion being rotatably mounted to the center base portion.

(21) Appl. No.: **09/815,321**

(22) Filed: **Mar. 22, 2001**

(65) **Prior Publication Data**

US 2002/0136010 A1 Sep. 26, 2002

(51) **Int. Cl.**<sup>7</sup> ..... **F21Y 21/14**

(52) **U.S. Cl.** ..... **362/250; 362/372**

(58) **Field of Search** ..... **362/250, 372**

(56) **References Cited**

**U.S. PATENT DOCUMENTS**

4,855,884 A \* 8/1989 Richardson ..... 362/278  
5,084,804 A \* 1/1992 Schairer ..... 362/245  
5,101,326 A 3/1992 Roney  
5,580,163 A \* 12/1996 Johnson, II ..... 362/239  
5,752,766 A \* 5/1998 Bailey et al. .... 362/231

**56 Claims, 15 Drawing Sheets**

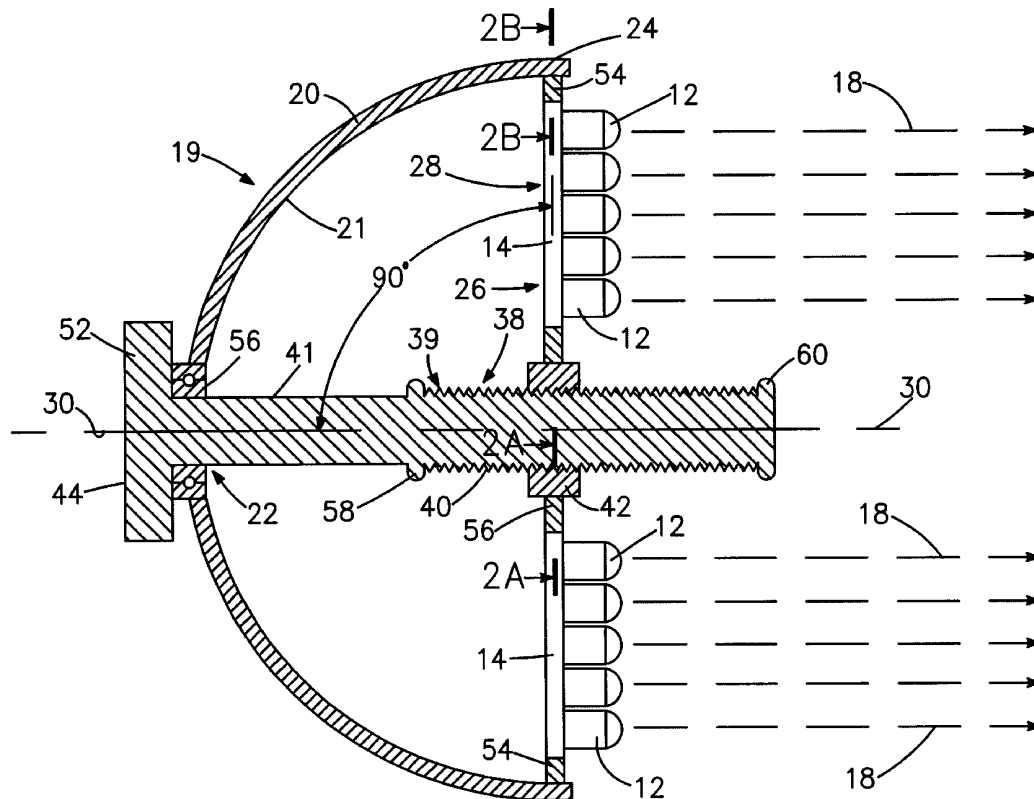

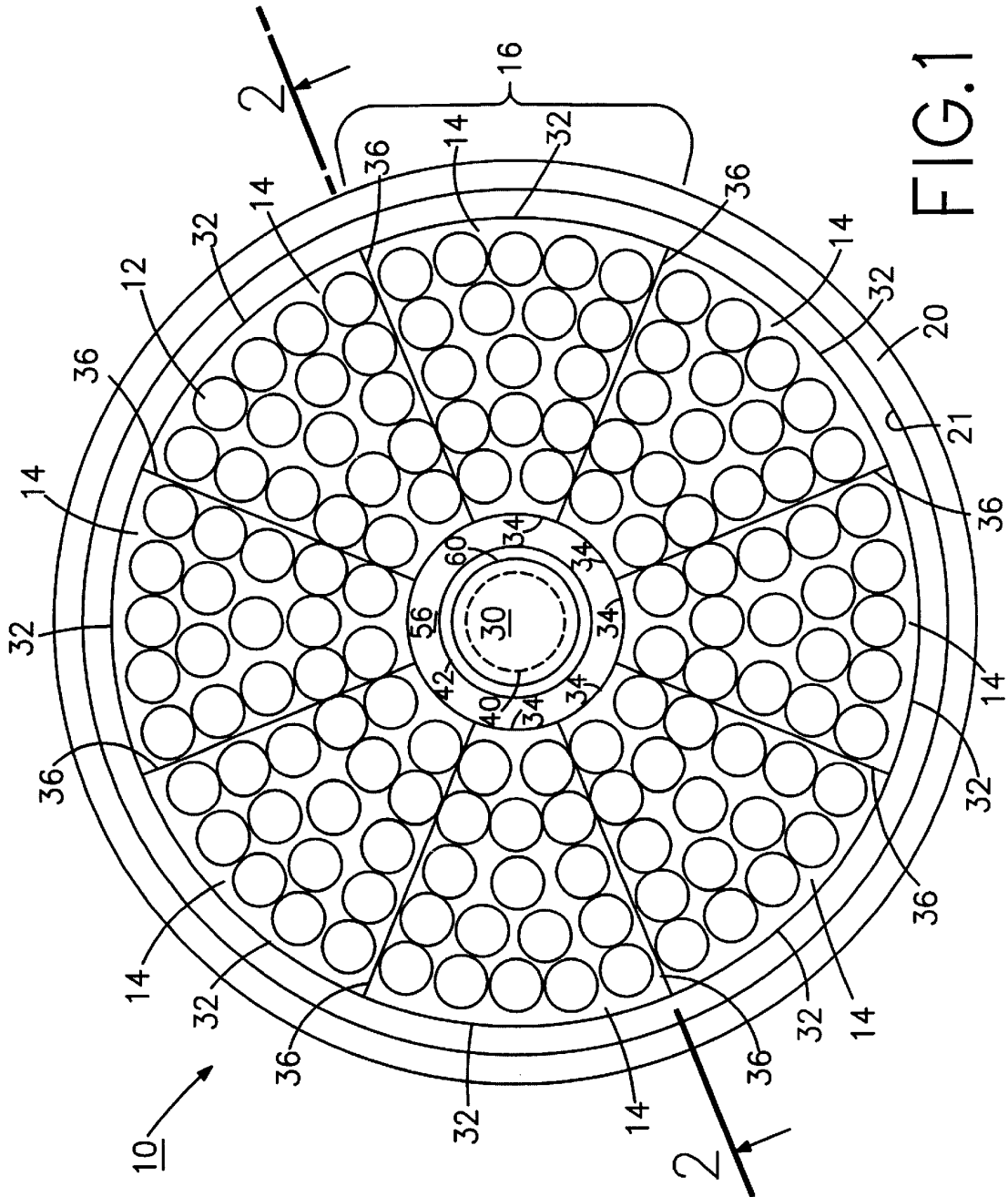

FIG. 1



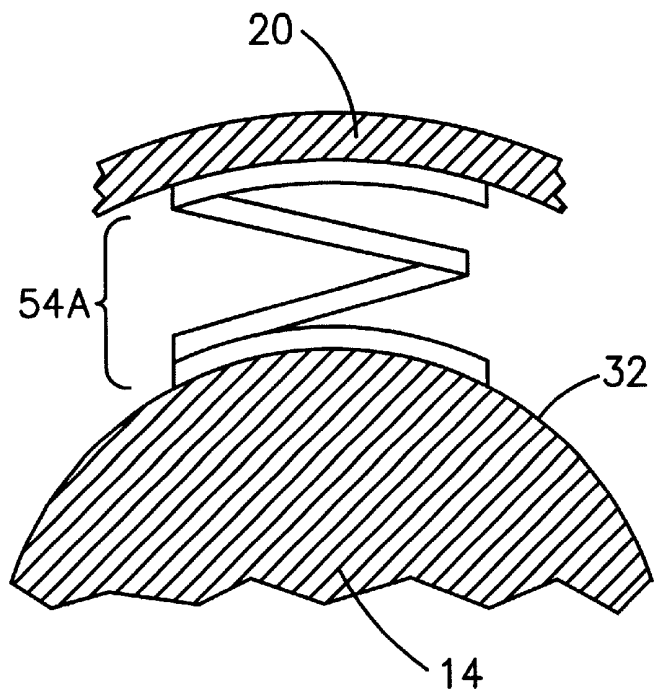

FIG. 2B

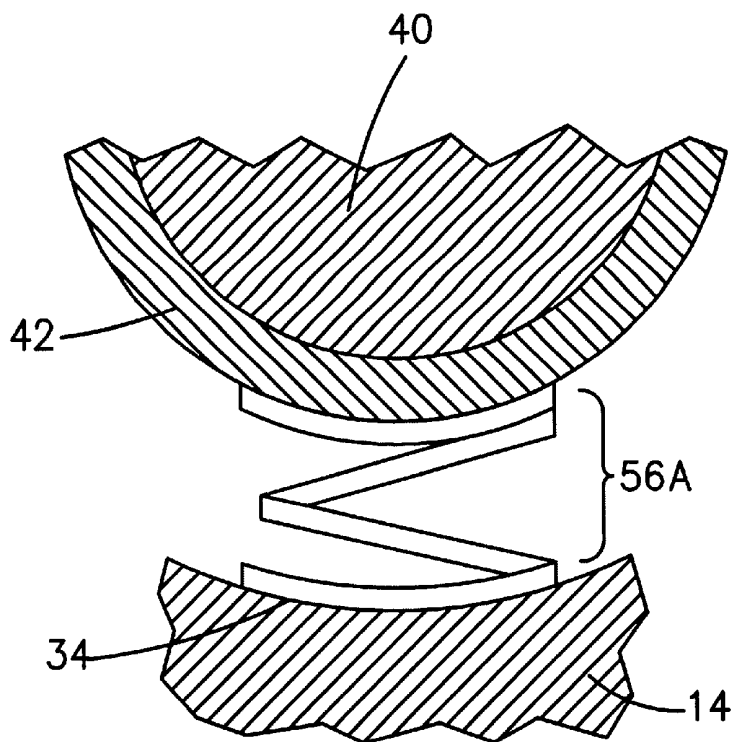

FIG. 2A

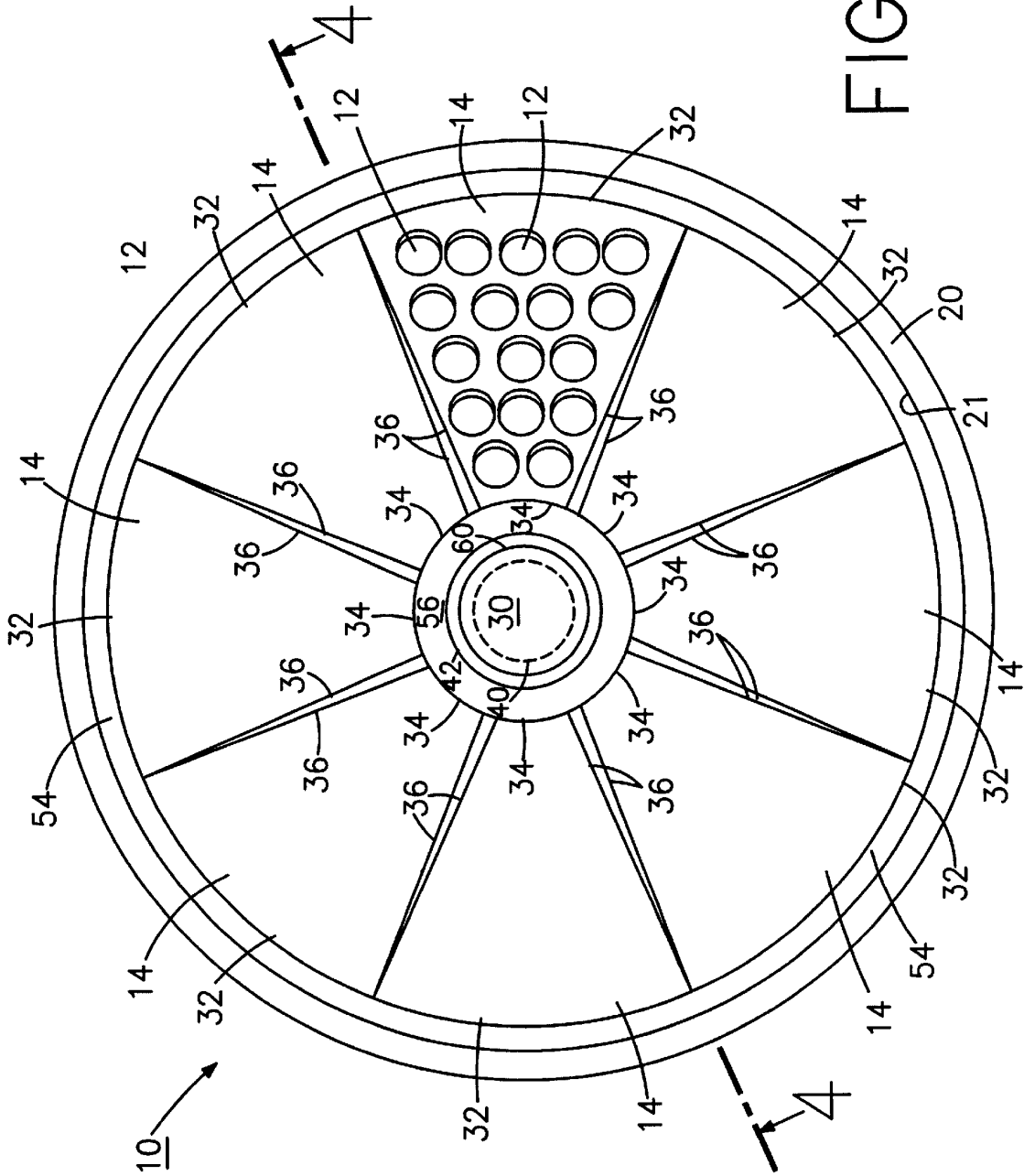

FIG. 3

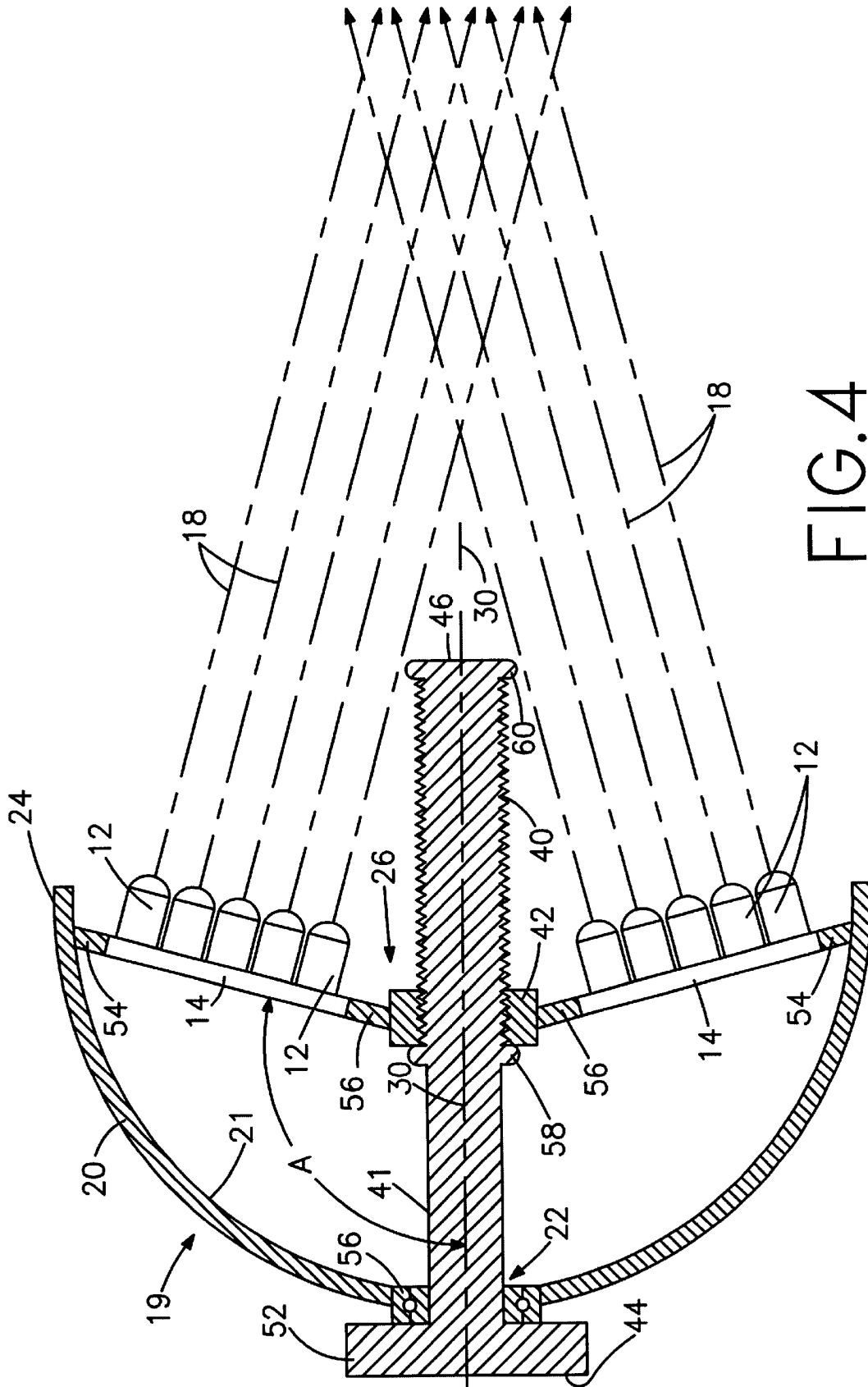
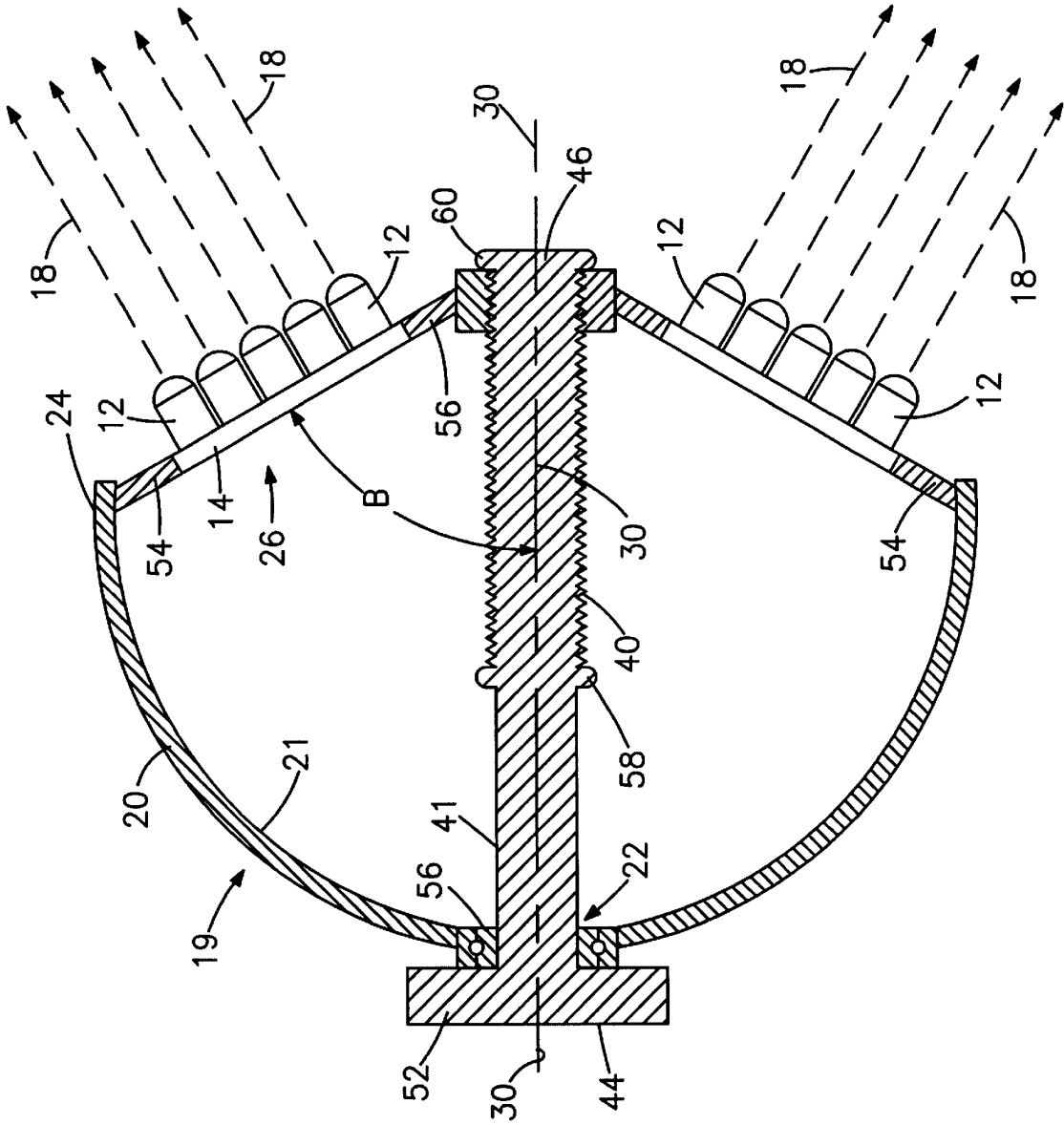
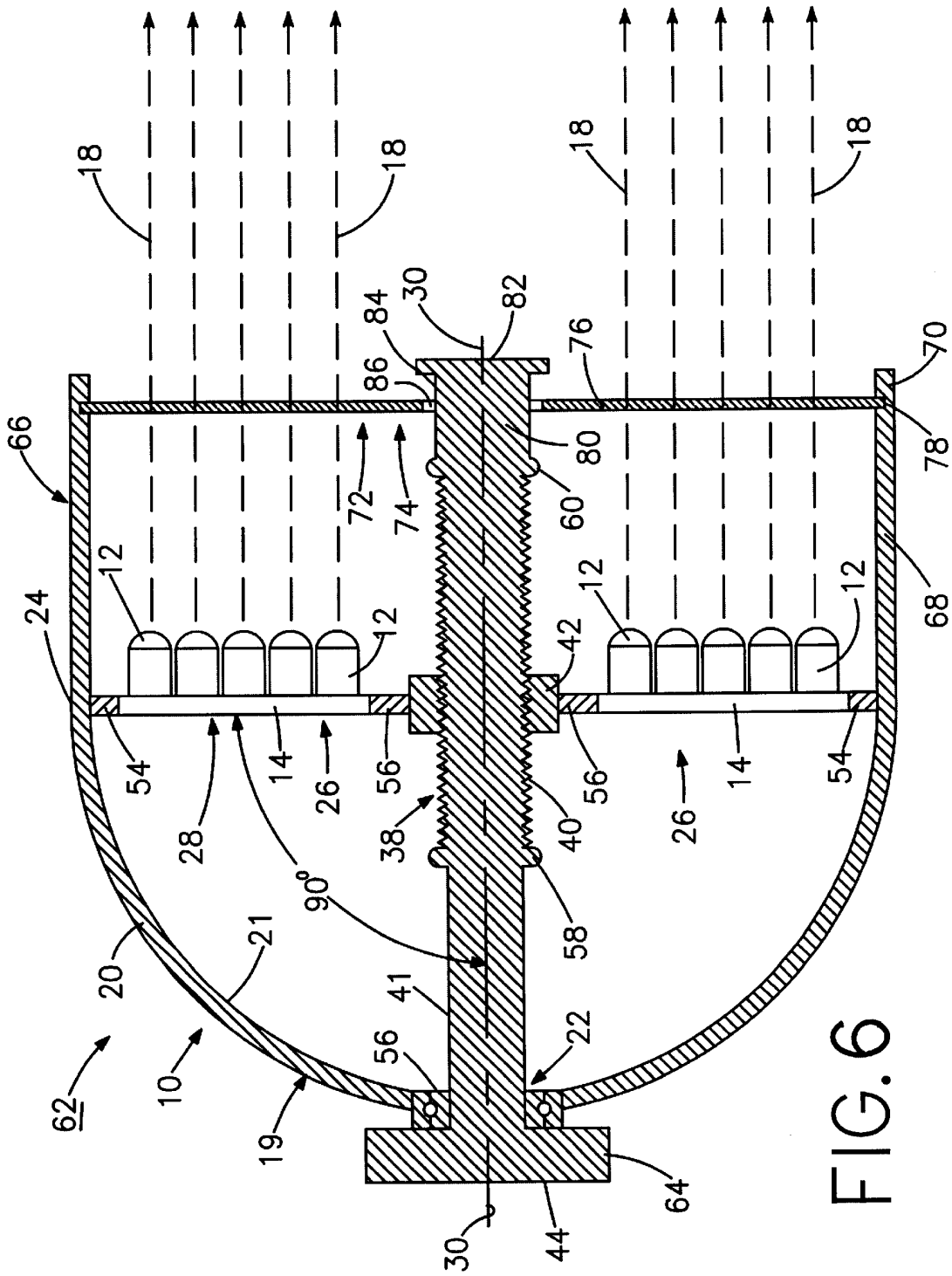

FIG.4

FIG. 5





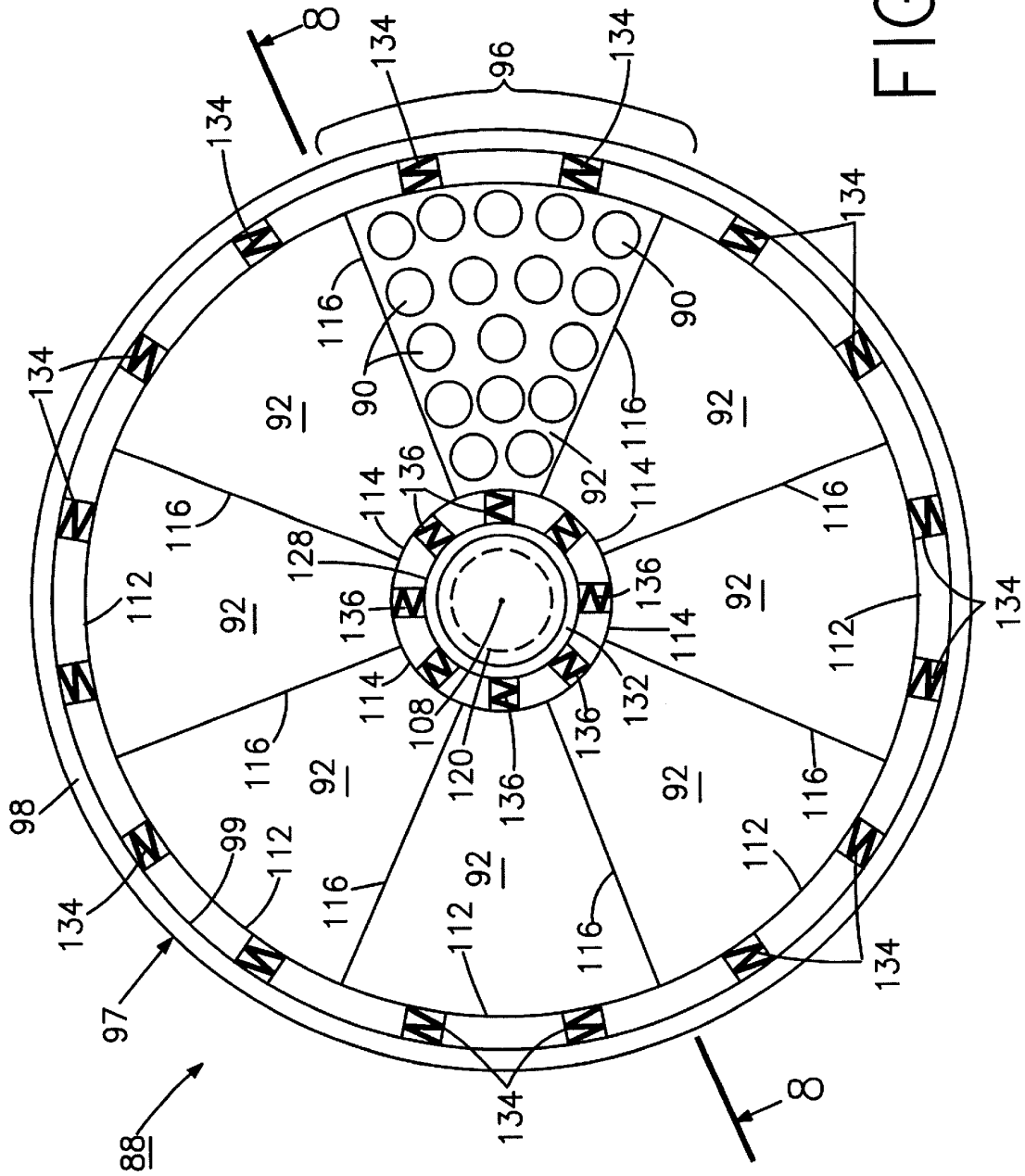

FIG. 7



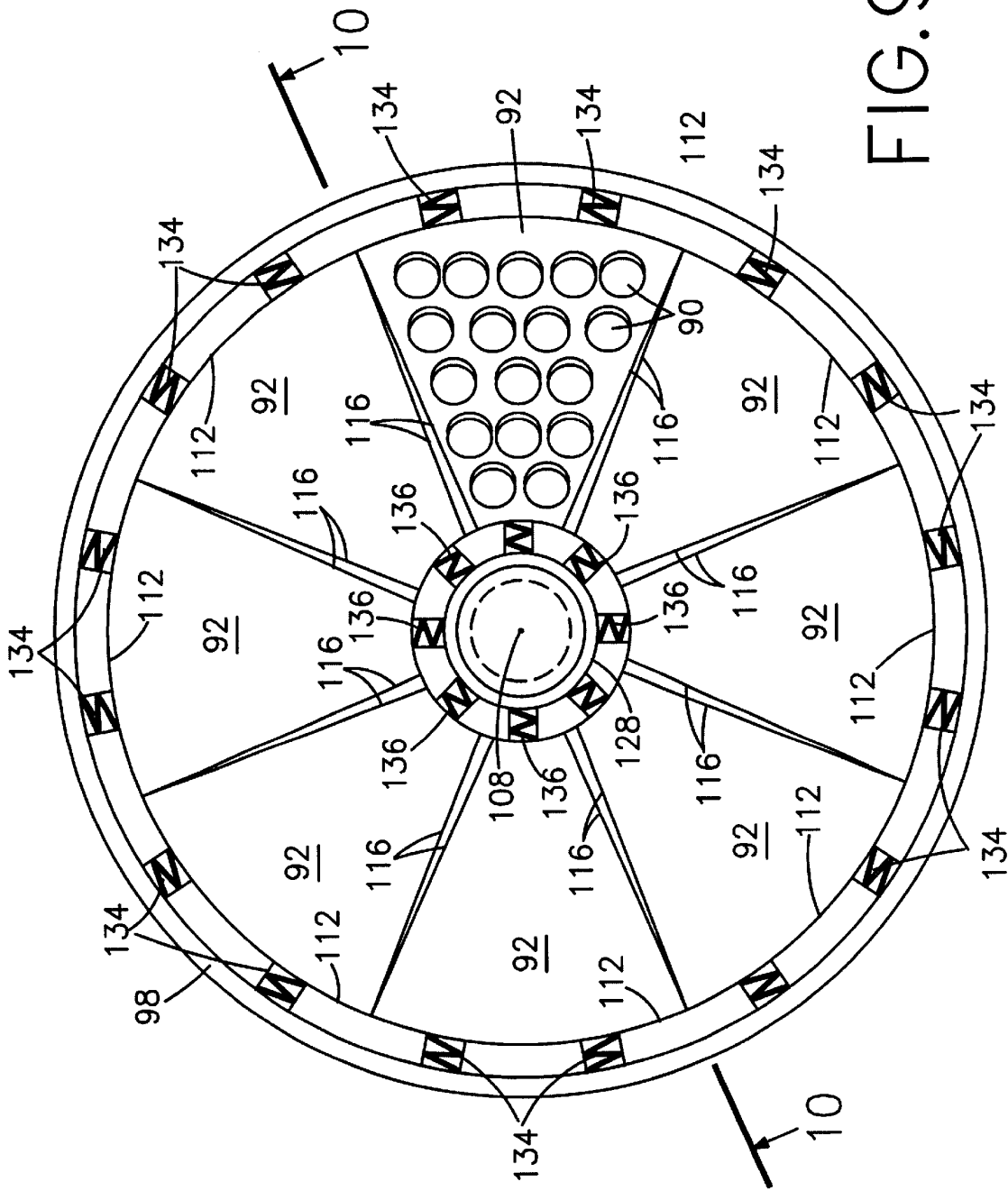

FIG. 9

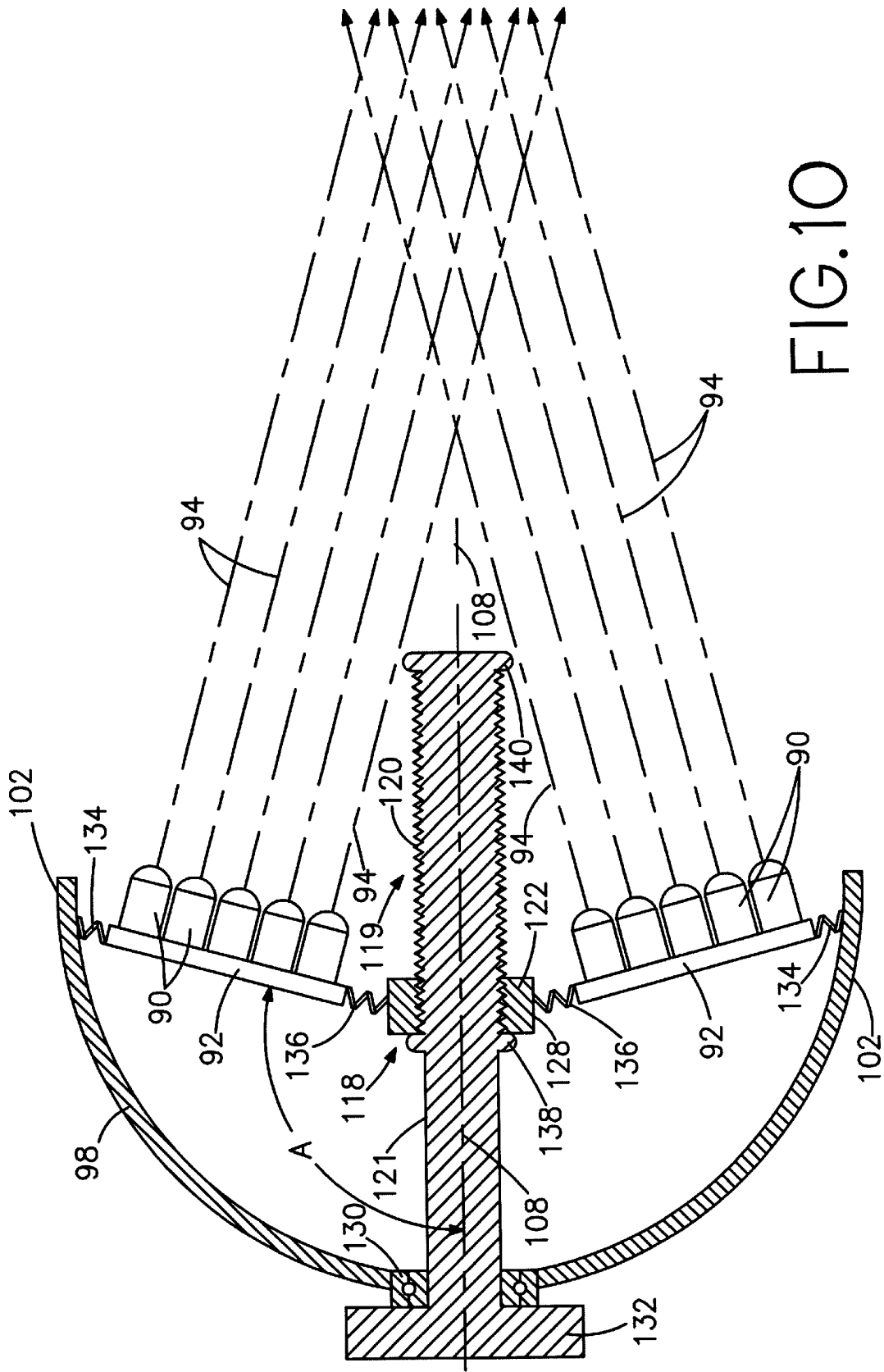
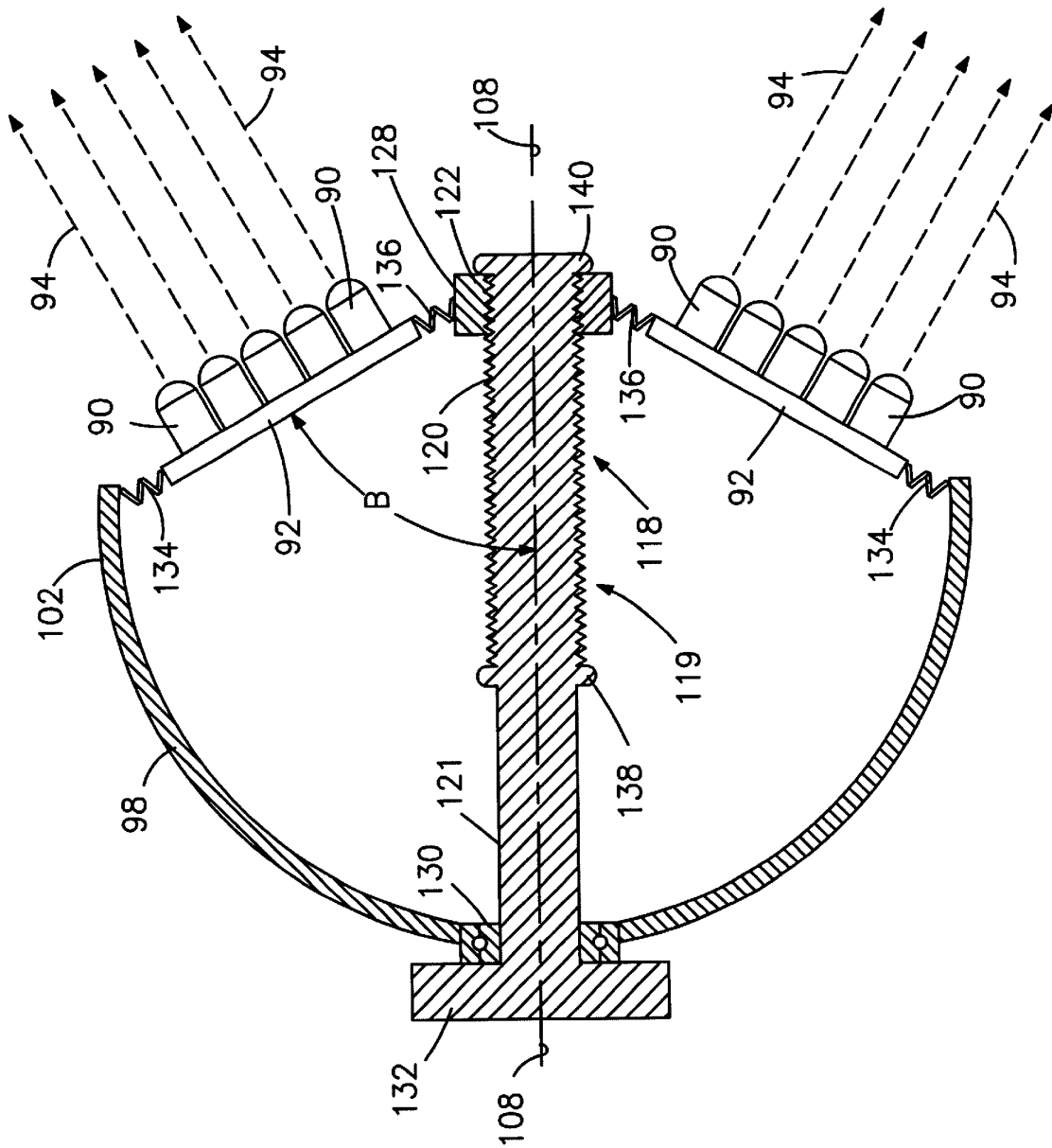

FIG.10

FIG. 11





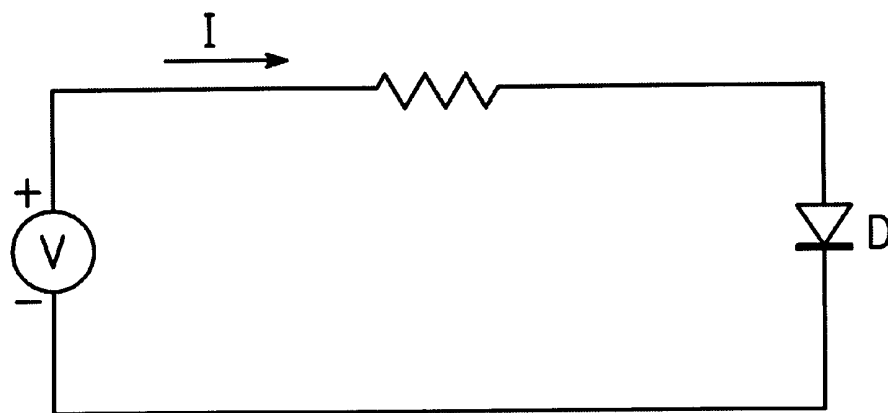

FIG.13

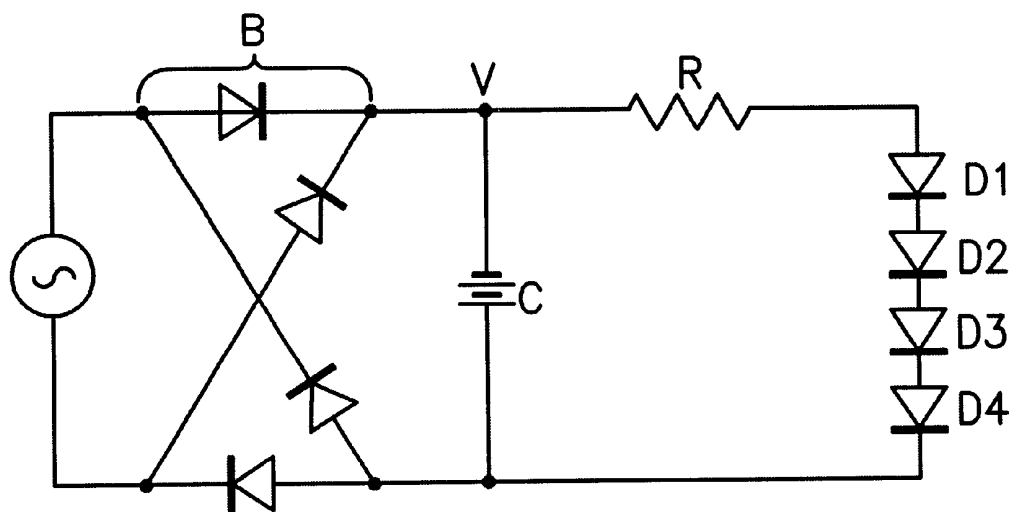

FIG.14

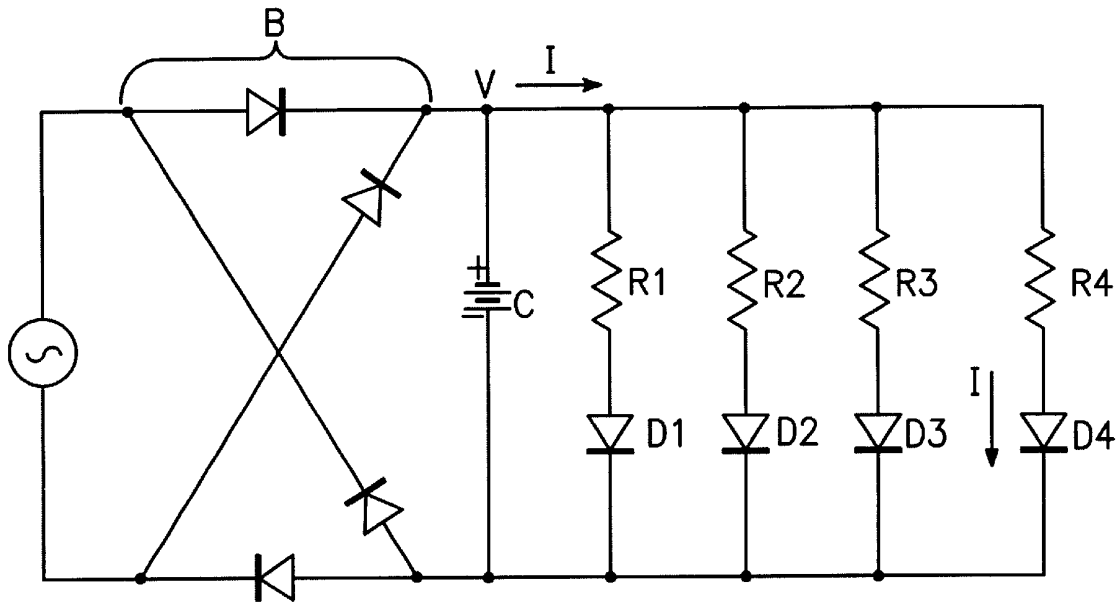

FIG.15

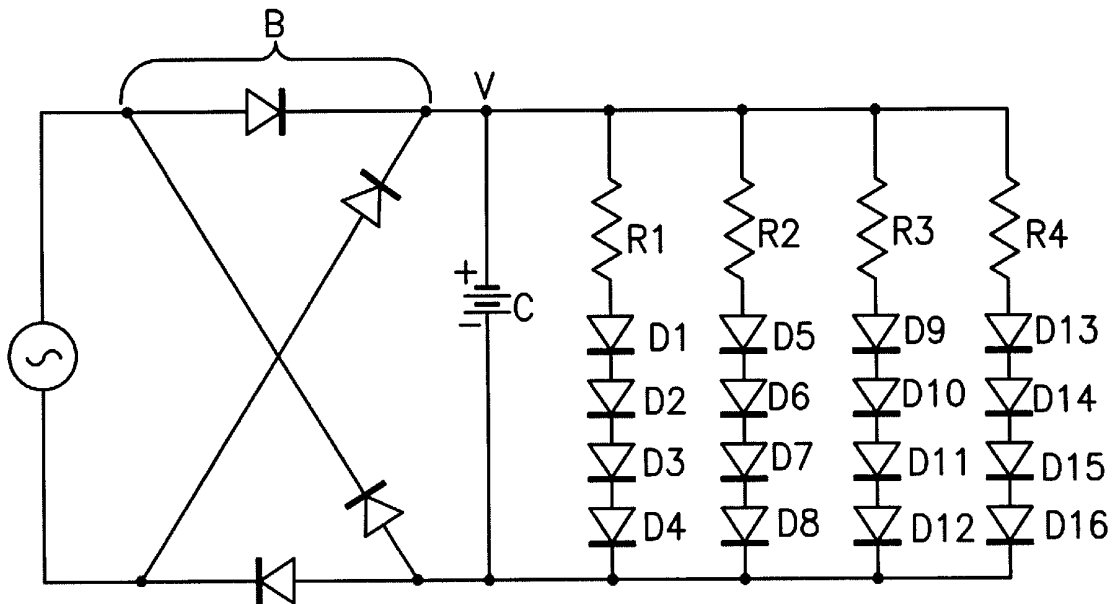

FIG.16

## VARIABLE BEAM LIGHT EMITTING DIODE LIGHT SOURCE SYSTEM

### FIELD OF THE INVENTION

The present invention relates to illumination for theatrical, architectural and stage lighting systems.

### BACKGROUND OF THE INVENTION

Longer life and more energy efficient sources of light have become increasingly important thus making alternative light sources important. Recent advances in light emitting diode (LED) technology particularly the development of multi-chip and multi-LED arrays have led to brighter LEDs available in different colors. LEDs are available in both visible colors and infrared. In addition to red, yellow, green, and amber-orange, which were the first available colors, LEDs are now available in blue and even white light. LEDs operate at lower currents and yet produce 100 percent color intensity and light energy. For many applications, LEDs can compete directly with incandescent filament light sources.

LEDs emit a focused beam of color light in a variety of different angles, in contrast to incandescent filament lamps, which emit only the full spectrum of light. In order to obtain color from an incandescent filament lamp, a specific color gel or filter in the desired color spectrum must be used. Such a system results in 90 percent or more of the light energy wasted by the incandescent filament lamp. LEDs on the other hand deliver 100 percent of their energy as light and so produce a more intense colored light. White light is also produced more advantageously by LEDs. White light is obtained from LEDs in two ways: first, by using special white light LEDs; and second, by using an additive mixture of red, green and blue (RGB) LEDs at the same intensity level so as to produce a white light. With regard to the second method, variable intensity combinations of RGB LEDs will give the full color spectrum with 100 percent color intensity and light output energy. The primary colors red, green, and blue of RGB LEDs can be mixed to produce the secondary colors cyan, yellow, magenta (CYM) and also white light. Mixing green and blue gives cyan, as is known in the art of colors. Likewise as is known in the art, mixing green and red gives yellow. Mixing red and blue gives magenta. Mixing red, green, and blue together results in white. Advances in light-emitting diode technology include the development of multi-chip and multi-LED arrays, which have led to brighter LEDs available in different colors. LEDs are available in both visible colors and infrared.

LEDs are more energy efficient as well. They use only a fraction of the power required by conventional incandescent filament lamps. The solid state design of LEDs results in great durability and robustness to withstand shock, vibration, frequent power cycling, and extreme temperatures. LEDs have a typical 100,000 hours or more usable life when they are operated within their electrical specifications. Incandescent filament lamps are capable of generating high-intensity light for only a relatively short period of time and in addition are very susceptible to damage from both shock and vibration.

Incandescent filament lamps of the MR and PAR type are the best known and most widely used technologies of the architectural, theatrical and stage lighting industry. Such lamps are available in different beam angles, producing beam angles ranging from narrow spot lights to wide flood focuses. Such types of lamps are very popular because they have long-rated lives up to 5,000 hours.

Light emitting diode LED technology including white light and full color red, green, blue (RGB) tile array modules have become common in certain areas of illumination, most commonly for large scale lighted billboard displays. Such LED light sources incorporate sturdy, fast-moving and animated graphics with full color. Such flat displays offer only one fixed viewing angle, usually at 100 degrees.

Another use of fixed flat panels for LED arrays are currently used in traffic lights and for stop lights and warning hazard lights mounted on the rear of automobiles.

A recent advance in LED lamp technology has been ICOLOR (a registered trademark of Color Kinetics Inc., 10 Milk Street, Boston, Mass. 02108) MR light sources introduced by such company, and the ICOLOR MR light source is a digital color-changing lamp, which plugs into standard MR 16 type lighting fixtures. This lamp has the advantage of using variable intensity colored LEDs with a long-life of 100,000 hours or more. On the other hand, it has a fixed LED array that is limited to a fixed beam angle of 22 degrees (SPOT). Similarly, Boca Flashes, Inc. offers a compact LED array of up to 24 LEDs in a typical dichroic coated glass reflector. The beam angle is limited to 20°.

Another LED light source in use today takes the form of a flashing warning beacon. The LEDs are arranged in a cylindrical array around the circumference of a tube base. This configuration allows for viewing from a 360 degree angle. The same configuration is also used in wedge base type LED lamps as well as in LED bulbs mounted on a standard screw base.

MR and PAR type incandescent filament lamps are able to be controlled to produce complete control of output beam angles. MR and PAR lamps are fixed focus and are not adapted to control beam angles. LED technology to date does not offer complete control of output beam angles.

Some patents that have addressed this problem are as follows:

1) U.S. Pat. No. 5,752,766 issued to Bailey et al. on May 19, 1998, discloses a focusable lighting apparatus for illuminating area for visual display. A flexible base member, shown in this patent as a cylindrical base member **20**, is supported on a housing and an array of LEDs **22** are supported on the flexible base member. An actuator connected to the base member is operable to move the flexible base member to selected working positions so as to direct LED generated light beams normally, inwardly or outwardly. The LEDs are supported on the flexible base **20**. Base **20** can be deflected (see col. 3, lines 45-49 and also col. 4, lines 43-46) so that the optical axes **39a** in a parallel mode is made to provide converging light beams indicated by the three lines **39b** shown in FIG. 2 thereof, and the bending of flexible base **20** is accomplished by actuator **28** by way of a rod **26** with the second flexed position shown in phantom. It is apparent that the range of beam angles that can be achieved by pulling or pushing flexible base member **20** is limited by the unitary structure of base member **20**. Base member **20** itself is described as flexible so that stretching of base member **20** itself is necessary to change the diode beam angles. The material composition of flexible member **20** is described as being made of any of various polymer or elastomer materials (col. 4, lines 51-62). The unitary structure of base **20** creates a built-in limitation position (col. 4, lines 53-62). The invention described therein has a limitation to its usefulness in the field of stage and theatrical lighting. It is also noted that the limited strength of elastomer base **20** itself to maintain constant diode beam angles is compromised so that the beam angles are signifi-

cantly misdirected since the diodes 20 cannot maintain constant angles relative to the plane of flexible member 20 because flexible member 20 itself undergoes a warping effect and so maintains no constant plane angle except in the parallel beam mode. Also, the number of diodes 22 that can be mounted to base member 20 is limited by the “relatively thin” (col. 2, line 59) base member 20. Also, permanent molding of the light emitting elements seems necessary, which indicates a difficulty in replacing the elements when they fail.

2) U.S. Pat. No. 5,580,163 issued to Johnson on Dec. 3, 1996, discloses a plurality of light emitting elements including light bulbs and LEDs attached to a circular flexible membrane that in turn is connected to outer and inner housing that are movable relative to one another so as to flex the membrane in a predetermined manner. The inner housing is threaded into an adjusting nut that can be rotated to move the inner housing relative to the outer housing. The light emitting elements are correspondingly moved so that their collective light beams are selectively focused at a common area. In this invention, the mounting of the light emitting elements is restricted to a circular membrane. It is apparent that the number of light emitting elements are restricted. FIG. 6 of Johnson shows an increased number of light emitting elements but again this view emphasizes the limitation of lighting elements available on this device. The number of elements is limited primarily by the fact that the flexible membrane can support a restricted number of light emitting elements just as a weight bearing problem. It is further noted that because of the flexibility of the membrane holding the light emitting elements, each element will to some degree be significantly misdirected because of the warping effect of the flexible membrane as it is moved between positions. Also permanent molding of the light emitting elements are discussed, which indicates a difficulty in replacing the elements when they fail.

3) U.S. Pat. No. 5,101,326 issued to Roney on Mar. 31, 1992, discloses a lamp for a motor vehicle that discloses a plurality of light emitting diodes positioned in sockets that direct the diode generated light beams in overlapping relationship so as to meet photometric requirements set forth by law. The diodes are not selectively movable to different focal areas.

4) U.S. Pat. No. 5,084,804 issued to Schaier on Jan. 28, 1992, discloses a wide area lamp comprising a plurality of diodes mounted on a single flexible connecting path structure than can be moved to a number of shapes as required. The diodes of the disclosed lamp are not collectively and selectively adjustable in a uniform manner for being directed to a common focal area.

#### SUMMARY OF THE INVENTION

It is an object of the present invention to provide a lighting system that is capable of providing a plurality of selected different light beam angles from a single LED lighting system source;

It is a further object of the present invention to provide a lighting system that is capable of selectively varying the common directional angles of a plurality of individual LED arrays arranged around a common central axis;

It is a further object of the present invention to provide a lighting system that is capable of simultaneously and selectively moving a plurality of individual LED arrays about a common central axis to as to collectively arrange the totality of LED light beams arranged on individual arrays in a plurality of directional modes including a normal parallel

mode of all of the LED generated light beams, a selected converging mode of all of the LED generated light beams, and a selected diverging mode of all of the LED generated light beams.

In accordance with the above objects and others that will be disclosed in the course of the disclosure of the present invention, there is provided a diode light source system for stage, theatrical and architectural lighting that includes a plurality of separate flat panels for mounting a plurality of light emitting diodes that emit a plurality of diode light beams to a common focus area, each separate panel being mounted with a plurality of grouped diodes of the plurality of diodes, each separate panel having an outer panel portion and an inner panel portion. A housing containing the panels has a center base portion and a circular rim defining a housing aperture aligned with a circular rim plane having a rim plane center that is arranged transverse to an axis aligned with the center base portion. A first connecting means flexibly secures each outer diode panel portion to the housing rim. A screw arrangement positions the panels at a plurality of selected positions wherein each of the panels is oriented at a selected angle relative to the axis and each of the grouped diodes emit diode light beams transverse to each separate panel. A second connecting means flexibly secures each inner panel portion to the screw arrangement. The panels are flat and rigid and have both the function of holding the diodes and of being electrical circuit boards for transmitting direct electrical current to the diodes grouped on each separate panel. The screw arrangement comprises an elongated externally threaded cylinder and a correspondingly internally threaded cylindrical nut, the externally threaded cylinder, which is rotatable about the axis, being threadably mounted within the cylindrical nut. The externally threaded cylinder has the circular rim plane. The first and second flexible connecting means can each be either a biasable or flexible member or a biasable spring.

The present invention will be better understood and the objects and important features, other than those specifically set forth above, will become apparent when consideration is given to the following details and description, which when taken in conjunction with the annexed drawings, describes, illustrates, and shows preferred embodiments or modifications of the present invention and what is presently considered and believed to be the best mode of practice in the principles thereof.

Other embodiments or modifications may be suggested to those having the benefit of the teachings therein, and such other embodiments or modifications are intended to be reserved especially as they fall within the scope and spirit of the subjoined claims.

#### DESCRIPTION OF THE DRAWINGS

FIG. 1 is a frontal view of my new and novel variable beam lighting system that shows a plurality of diodes mounted on eight wedge-shaped mounting/circuit board diode panels in the normal, or parallel beam, mode of the diodes;

FIG. 2 is a side center sectional view of a outer flexible hinge area of the panels taken through line 2—2 of my invention shown in FIG. 1;

FIG. 2A is a sectional view of the flexible inner flexible hinge area of the diode panels taken through line 2A—2A of FIG. 2;

FIG. 2B is a sectional view taken though line 2B—2B of FIG. 2;

FIG. 3 is a frontal view of the lighting system as shown in FIG. 1 with the eight diode panels in a full forward mode

5

with one diode panel shown mounted with diodes for purposes of convenience;

FIG. 4 is a sectional view of the lighting system taken through line 4—4 in FIG. 3 showing the diode light beams in a converging beam mode;

FIG. 5 is a sectional side view of the lighting system analogous to the view shown in FIG. 4 with the diode panels in the rearward mode showing the diode light beams in a diverging mode;

FIG. 6 is a sectional view of another embodiment of the lighting system analogous to the view shown in FIG. 3 with a protective lens positioned across the front of the housing and with a front hand wheel;

FIG. 7 is a frontal view of another embodiment of the variable beam lighting system that in particular shows a plurality of diodes mounted on eight wedge-shaped mounting board/circuit board diode panels indicating one diode panel with diodes for purposes of convenience in the normal, or parallel beam, mode of the diodes with outer and inner springs connecting the diode panels with both the housing and a center hollow cylinder;

FIG. 8 is a sectional side view of the lighting system taken through line 8—8 of FIG. 7 with the diode panels in the normal position showing the diode light beams in a parallel mode;

FIG. 9 is a frontal view of the lighting system as shown in FIG. 7 with the eight diode panels in a forward mode with one diode panel shown mounted with diodes for purposes of convenience;

FIG. 10 is a sectional side view taken through line 10—10 in FIG. 9 with the diode panels in rearward mode and showing the diode light beams in a converging mode;

FIG. 11 is a sectional side view of the lighting system analogous of the lighting system as shown in FIG. 7 with the diode panels in the forward mode and the diode light beams in a diverging mode;

FIG. 12 is a sectional side view of another embodiment of the lighting system analogous to the view shown in FIG. 8 with a protective lens positioned across the front of the housing and a front hand wheel.

FIG. 13 is a basic electrical diagram that relates to the selection of a single light emitting diode for a given direct current voltage;

FIG. 14 is a basic electrical diagram that relates to the selection of a plurality of light emitting diodes connected in series in electrical connection with a source of alternating current that has been converted to direct current voltage;

FIG. 15 is a basic electrical diagram that relates to the selection of a plurality of light emitting diodes connected in parallel in electrical connection with a source of alternating current that has been converted to direct current voltage; and

FIG. 16 is a basic electrical diagram that relates to the selection of a plurality of light emitting diodes connected both in series and in parallel in electrical connection with a source of alternating current that has been converted to direct current voltage.

#### DETAILED DESCRIPTION OF THE INVENTION

Reference is now made to the drawings and in particular to FIGS. 1—16 in which identical or similar parts are designated by the same reference numerals throughout.

A light source system 10 for stage, theatrical and architectural lighting as shown in FIGS. 1—6 includes a plurality

6

of light emitting diodes (LEDs) 12, referred to as diodes herein, that are mounted on eight separate flat diode panels 14 so as to emit diode light beams 18 towards a common focus area as seen in one directional mode in FIG. 2. The number of diode panels 14 are shown as eight for purposes of exposition only and can vary in number. A panel diode group 16 includes seventeen diodes 12 per diode panel 14 for a total of 136 diodes 12 for the total array of diodes 12 for light source system 10. The number of diodes 12 per diode panel 14 is shown as seventeen for purposes of exposition only and can vary. Each diode group 16 emits a common group of seventeen diode light beams 18 in parallel relationship.

FIG. 2 shows a housing 19 for containing and holding diode panels 14 and diodes 12. Housing 19 defines a concave hollow volume shown as semi-spherical in configuration for purposes of exposition but the configuration of housing 19 is preferably of any regular configuration such as semi-ellipsoidal, cone-shaped, and parabolic. Housing 19 has a housing wall 20 preferably having a microreflective inner surface 21. Housing 19 has a center base portion 22 and a circular rim 24 that in turn defines a circular aperture 26 that lies in a housing plane 28. The center of circular aperture 26 is in an axial alignment indicated in FIG. 3 as axis 30 with center base portion 22. Each separate diode panel 14 is configured as a wedge with a panel outer arc edge 32 and a panel inner arc edge 34 and panel linear side edges 36 that taper inwardly from panel outer arc edge 32 to panel inner arc edge 34. All diode panels 14 are movable between adjacent panel relationships and separated panel relationships.

A beam direction selection screw mechanism or arrangement 38 positions each diode panel 14 between a plurality of selected positions relative to housing axis 30 wherein each diode panel 14 is oriented at a predetermined angle relative to axis 30. As a result, each panel diode group 16 emits diode light beams 18 at a beam angle transverse to the predetermined angle of panels 14. Screw arrangement 38 is secured to housing 19 and to each diode panel 14 at panel inner arc edge 34.

Screw arrangement 38 comprises an elongated externally spirally threaded solid cylinder 39 that includes a threaded portion 40 and an unthreaded portion 41, which extends between threaded portion 40, and center base portion 22 and a correspondingly internally threaded cylindrical nut 42. Externally threaded solid cylinder 39 is threadably mounted within cylindrical nut 42. Externally threaded solid cylinder 39 is rotatably aligned with axis 30 of housing 19 and extends external to housing plane 28.

Externally threaded cylinder 39 has opposed inner and outer end portions 44 and 46, respectively. Inner end portion 44 is rotatably mounted to housing 19 at center base portion 22. Outer end portion 46 is positioned spaced from housing plane 28. Internally threaded cylinder nut 42 has a cylindrical outer surface 48. Center base portion 22 defines an aperture wherein is mounted bearings 50 through which externally threaded solid cylinder 39 extends external to housing 19. A handwheel 52 is mounted to externally threaded solid cylinder 39 external to housing 19.

A flexible and biasable cylindrical outer connecting ring 54 has an arced outer edge that is connected to the arced microreflective inner surface 21 of housing wall 20 at the circular inner side of the circular rim 24 by a means known in the art. Housing 19 and outer connecting ring 54 are preferably made of plastic and can be connected one to the other by a means known in the art such as by heat fusing.

7

Alternatively, fixing pins (not shown) can be extended through housing wall 21 and a flap (not shown) of connecting ring 54. Outer connecting ring 54 further has an arced inner edge that is connected to panel outer arc edge 32 in a manner known in the art, for example, by fixing pins. A flexible and biasable cylindrical inner connecting ring 56 has an arced outer edge that is connected to panel inner arc edge 34 by a means known in the art, for example, by fixing pins. Cylindrical inner connecting ring 56 has an arced inner edge that is connected to the cylindrical wall of nut 42 by a means known in the art. For example, nut 42 is preferably made of a rigid plastic material and inner connecting member is likewise of plastic so that nut 42 and inner connecting ring 56 can be heat fused.

FIG. 2A shows an alternate flexible connecting ring 54A that secures inner panel arc edge 34 to connecting nut 42 wherein connecting ring 54A is creased to stretch and to compress by unfolding and folding, respectively, in the manner of an accordion or bellows between a normal folded mode as shown in FIG. 2A and an expanded mode (not shown).

FIG. 2B shows an alternate flexible connecting ring 56A that secures outer panel arc edge 32 to housing rim 24 wherein connecting ring 56A is creased to stretch and to compress by unfolding and folding, respectively, in the manner of an accordion between a normal folded mode as shown in FIG. 2B and an expanded mode (not shown).

Screw arrangement 38 is operable by rotation of handwheel 52 at inner end portion 44 in either a clockwise or a counterclockwise direction. When handwheel 52 is rotated in the clockwise direction when diode panels 14 are in the position shown in FIG. 2, wherein diode panels 14 lie in housing plane 28 as shown in FIG. 2, and externally threaded solid cylinder 39 rotates clockwise relative to cylindrical nut 42 wherein panel linear side edges 36 are drawn inwardly, or apart. Continued counterclockwise rotation can continue until cylindrical nut 42 is restrained by an internal cylindrical stop 58 connected to externally threaded cylinder 39, a position shown in FIG. 4. Internal stop 58 is positioned spaced from center base portion 22. When handwheel 52 is rotated in the clockwise direction from the position shown in FIG. 2, externally threaded solid cylinder 40 rotates clockwise relative to cylindrical nut 42 wherein panel linear side edges 36 are pushed outwardly, or apart. Continued counterclockwise rotation can continue until cylindrical nut 42 is restrained by an external cylindrical stop 60 positioned at outer end portion 46 of externally threaded cylinder 40, a position shown in FIG. 5.

FIGS. 1 and 2 show all diode panels 14 in a selected position wherein diode panels 14 are aligned with housing plane 28 wherein diode panels 14 are aligned with housing plane 28 and also are aligned at a 90 degree angle relative to axis 30 and to threaded cylinder 40. In this selected position diode light beams 18 of all diode panels 14 are oriented in parallel relative to axis 30 wherein the diode beam angle is in a normal beam mode towards a common focus area.

FIGS. 3 and 4 show all diode panels 14 in a selected position wherein diode panels 14 are positioned oriented at a selected common obtuse angle A as measured relative to housing axis 30, that is, to externally threaded cylinder 40, and inner end portion 44 of cylinder 40. In this position diode light beams 18 emanating from diodes 12 positioned on all diode panels 14 are in a converging mode. The selected converging mode of diode light beams 18 as shown in FIGS. 3 and 4 is at the maximum converging mode of

8

diode light beams 18 wherein cylindrical nut 42 is positioned in contact with a cylindrical internal stop 58 connected to externally threaded cylinder 40 that is spaced from inner end portion 44 of externally threaded cylinder 40 and in particular is located at the inner end of threaded portion 40. Any of a plurality of converging mode orientations of diode light beams 18 can be selected by positioning cylindrical nut 42 at any of a plurality of selected positions between the normal, or parallel light beam mode, of diode light beams 18 as shown in FIG. 2 and the maximum converging mode of diode light beams 18 towards a common focus area as shown in FIG. 4. In the maximum converging mode diode light beams 18 by pass outer end portion 46 of externally threaded cylinder 40.

FIG. 5 shows all diode panels 14 in a selected position wherein diode panels 14 are positioned oriented at a selected common acute angle B relative to axis 30 as measured relative to housing axis 30, that is, to externally threaded cylinder 40, and inner end portion 44 of threaded cylinder 40. In this position diode light beams 18 emanating from all diodes 14 positioned on diode panels 14 are focused toward a common focus area. In this position diode light beams 18 are in a diverging mode. The selected diverging mode of diode light beams 18 as shown in FIG. 5 is at the maximum diverging mode of diode light beams 18 wherein cylindrical nut 42 is positioned in contact with a cylindrical external stop 60 connected to outer end portion 46 of externally threaded cylinder 40.

FIG. 6 shows a diode lighting system embodiment 62 generally analogous to diode lighting system 10 that includes housing 19 with rim 24 defining circular aperture 26 and diodes 12 mounted to eight diode panels 14. Screw arrangement 38 including externally threaded solid cylinder 40 having opposed inner and outer end portions 44 and 46, respectively, and internally threaded cylindrical nut 42 threaded thereto is mounted in housing 19 at inner end portion 44 in alignment with a central housing axis 30. An optional handwheel 64 is positioned external to housing 19 at inner end portion 44. Eight diode panels 14 having diodes 12 mounted thereto are connected to housing 19 at circular rim 24 exactly as shown in FIGS. 1 and 2. Flexible internal and outer connecting rings 54 and 56, respectively, connect diode panels 14 to cylindrical nut 42 as shown in FIGS. 1 and 2. Internal and external stops 58 and 60, respectively, are mounted to externally threaded cylinder 40 as described in relation to diode lighting system 10 and as shown in FIGS. 1 and 2.

As shown in FIG. 6, a cylindrical extension member 66 that includes a cylindrical wall 68 is connected to rim 24 in axial alignment with housing axis 30 of housing 19. Cylindrical extension member 66 defines an extension member outer circular rim 70 that defines a circular aperture 72 that in turn lies in an extension member rim plane 74 that is perpendicular to housing axis 30. Extension member rim 70 and extension member rim plane 74 are spaced outwardly from outer end portion 46 and from external stop 60. A cylindrical protective lens 76 is mounted to extension member 66 in association with outer rim 70 and plane 74 in perpendicular relationship with axis 30. Lens 76 is mounted to outer rim 70 by any suitable means known in the art such as the interior side of rim 70 defining a circular groove 78 into which the circular edge of lens 76 is mounted. A cylindrical axial extension 80 of cylindrical threaded cylinder 40 is connected to outer end portion 46 and extends to an axial extension end 82 that is outwardly spaced from rim plane 74 and lens 76. An outer handwheel 84 is connected to axial extension end 82. Lens 76 defines an axially aligned

circular lens aperture **86** that has a lens aperture diameter. Cylindrical axial extension **80** has an axial extension diameter that is less than the diameter of circular lens aperture **86**. An operator can rotate outer handwheel **86** in either a clockwise or counterclockwise direction. When handwheel **86** is rotated in a clockwise direction, cylindrical nut **42** is moved axially towards external stop **60** wherein diode panels **14** are moved to the acute angle mode and diode light beams are moved towards the diverging mode shown in FIG. **5**. When handwheel **86** is rotated in a counterclockwise direction, cylindrical nut **42** is moved axially towards internal stop **58** wherein diode panels **14** are moved to the obtuse angle mode and diode light beams are moved towards the converging mode shown in FIG. **4**. Rotation of outer handwheel **84** in either rotational direction give the operator the option of moving diode panels **14** to any of a plurality of preselected positions.

An alternate embodiment of light source system **10** is light source system **88** shown in FIGS. **7–12**. Light source system **88** includes a plurality of light emitting diodes (LEDs) **90**, referred to as diodes herein, that are mounted on eight separate flat diode panels **92** so as to emit diode light beams **94** towards a common focus area as seen in one directional mode in FIG. **8**. The number of diode panels **92** are shown as eight for purposes of exposition only and can vary in number. A panel diode group **96** includes seventeen diodes **90** per diode panel **92** for a total of 136 diodes for the total array of diodes for light source system **88**. The number of diodes **90** per diode panel **92** is shown as seventeen for purposes of exposition only and can vary. Each diode group **96** emits a common group of seventeen diode light beams **94** in parallel relationship.

FIGS. **7** and **8** show a housing **97** for containing and holding diode panels **92** and diodes **90**. Housing **97** defines a concave hollow volume shown as semi-spherical in configuration for purposes of exposition but the configuration of housing **97** is preferably of any regular configuration such as semi-ellipsoidal, cone-shaped, and parabolic. Housing **97** has a housing wall **98** preferably having a microreflective inner surface **99**. Housing **97** has a center base portion **100** and a circular rim **102** that in turn defines a circular aperture **104** that lies in a housing aperture plane **106**. The center of circular aperture **104** is in an axial alignment indicated in FIG. **8** as axis **108** with center base portion **110**. Each separate diode panel **92** is configured as a wedge with a panel outer arc edge **112** and a panel inner arc edge **114** and panel linear side edges **116** that taper inwardly from panel outer arc edge **112** to panel inner arc edge **114**. All diode panels **92** are movable relative to one another so that all panel side edges **116** are movable between adjacent panel relationships and separated panel relationships between a plurality of selected positions relative to axis **108** wherein each diode panel **92** is oriented at a predetermined angle relative to axis **108**. As a result, each panel diode group **96** emits diode light beams **94** at a beam angle transverse to the predetermined angle of panels **92**. A beam direction selection screw mechanism or arrangement **118** is secured to housing **97** and to each diode panel **92** at panel inner arc edge **114**.

Screw arrangement **118** positions each diode panel **92** between a plurality of selected positions relative to axis **108** wherein each diode panel **92** is oriented at a predetermined angle relative to axis **108**. As a result, each panel diode group **96** emits diode light beams **94** at a beam angle transverse to the predetermined angle of panels **92**. Screw arrangement **118** is secured to housing **97** and to each diode panel **92** at panel inner arc edge **114**.

Screw arrangement **118** comprises an elongated externally spirally threaded solid cylinder **119** having a threaded portion **120** and an unthreaded portion **121** that extends between center base portion **110** and threaded portion **120** and a correspondingly internally threaded cylindrical nut **122**. Externally threaded solid cylinder **119** is threadably mounted within an internally threaded cylindrical nut **122**. Externally threaded solid cylinder **119** is rotatably aligned with axis **108** of housing **97** and extends external to housing rim aperture plane **106**. Externally threaded cylinder **119** has opposed inner and outer end portions **124** and **126**, respectively. Inner end portion **124** is rotatably mounted to housing **97** at center base portion **100**. Outer end portion **126** is positioned spaced from housing rim plane **106**. Internally threaded cylindrical nut **122** has a cylindrical outer surface **128**. Center base portion **100** defines an aperture wherein is mounted bearings **130** through which externally threaded cylinder **119** extends external to housing rim plane **106**. A handwheel **132** is mounted to externally threaded solid cylinder **119** external to housing wall **98**.

As shown in FIGS. **7–12**, diode panels **92** are flexibly and biasedly connected to housing **97**. Each panel outer arc edge **114** of each diode panel **92** is connected to housing wall **98** at circular rim **102** by two outer springs **134** that are secured both to each panel outer arc edge **112** and to housing wall **98** at housing rim **102** by a suitable means known in the art, for example by hook and ring. Two outer springs **134** are shown for purposes of exposition only and more than two outer springs **136** can be used.

Also, as shown in FIGS. **7–12**, diode panels **92** are flexibly and biasedly connected to cylindrical nut **122** and in particular are connected to outer end portion **126** of externally threaded cylinder **119**.

Screw arrangement **118** is operable by rotation of handwheel **132** at inner end portion **124** in either a clockwise or a counterclockwise direction. When handwheel **132** is rotated in the clockwise direction when diode panels **92** are positioned in the housing rim aperture plane **106** shown in FIG. **8**, externally threaded solid cylinder **119** rotates clockwise relative to cylindrical nut **122** wherein panel inner edges **114** are drawn inwardly relative to housing rim **102**. Continued counterclockwise rotation can continue until cylindrical nut **122** is restrained by an internal cylindrical stop **138** connected to threaded solid cylinder **119** at a position spaced from center base portion **110** in particular at the inner end of threaded portion **121**, a position shown in FIG. **10**. When handwheel **132** is rotated in the clockwise direction when diode panels **92** are in the position shown in FIG. **8** externally threaded solid cylinder **119** rotates clockwise relative to cylindrical nut **122** so that panel linear side edges **116** are pushed outwardly, or apart, relative to rim **102**. Continued counterclockwise rotation will result in cylindrical nut **122** being restrained by an external cylindrical stop **140** positioned at outer end portion **126** of externally threaded cylinder **119**, a position shown in FIG. **11**.

FIGS. **7** and **8** show all diode panels **92** in a selected position wherein diode panels **92** are aligned with housing rim aperture plane **106** and also are aligned at a 90 degree angle relative to housing axis **108** and to threaded cylinder **119**. In this selected position diode light beams **94** of all diode panels **92** are oriented relative to axis **108** wherein the angle of diode panels **92** is a diode panel angle of 90 degrees wherein the direction of diode beams is in a normal beam mode parallel to axis **108** towards a common focus area.

FIGS. **9** and **10** show all diode panels **92** in a selected position wherein diode panels **92** are positioned oriented at

a selected common obtuse angle A as measured relative to housing axis 108, that is, to externally threaded cylinder 119, and inner end portion 124 of externally threaded cylinder 119. In this position diode light beams 94 emanating from diodes 90 that are positioned on diode panels 92 are directed to a common focus area in a converging mode. The selected converging mode of diode light beams 94 as shown in FIGS. 9 and 10 is at the maximum converging mode of diode light beams 94 wherein cylindrical nut 122 is positioned in contact with cylindrical internal stop 138 connected to externally threaded cylinder 119. Any of a plurality of converging mode orientations of diode light beams 94 can be selected by positioning cylindrical nut 122 at any of a plurality of selected positions between the normal, or parallel light beam mode, of diode light beams 94 as shown in FIG. 8 and the maximum converging mode of diode light beams 94 shown in FIG. 10. In the maximum converging mode, diode light beams 94 bypass outer end portion 126 of externally threaded cylinder 119 and external stop 140.

FIG. 11 shows all diode panels 92 in a selected position wherein diode panels 92 are positioned oriented at a selected common acute angle B relative to axis 108 as measured relative to housing axis 108, that is, to externally threaded cylinder 119, and inner end portion 124 of externally threaded cylinder 119. In this position diode light beams 94 emanating from all diodes 90 positioned on diode panels 92 are directed towards a common focus area. In this position diode light beams 94 are in a diverging mode. The selected diverging mode of diode light beams 94 as shown in FIG. 11 is at the maximum diverging mode of diode light beams 94 wherein cylindrical nut 122 is positioned in contact with a cylindrical external stop 60.

FIG. 12 shows a diode lighting system embodiment 142 generally analogous to diode lighting system 88 that includes housing 97 and housing wall 98 with housing rim 106 defining circular aperture 104 lying in a housing rim aperture plane 106 and seventeen diodes 90 mounted to eight diode panels 92. Externally threaded solid cylinder 119 and the center of housing circular aperture 104 are aligned with an axis 108. Screw arrangement 118 including externally threaded solid cylinder 119 having opposed inner and outer end portions 124 and 126, respectively, and internally threaded cylindrical nut 122 threaded thereto is mounted within housing 97 with inner end portion 124 in alignment with central housing axis 108. An optional handwheel 144 is positioned external to housing wall 98 at inner end portion 124. Eight diode panels 92 having diodes 90 mounted thereto are connected to housing 97 at circular rim 102 as shown in FIGS. 7, 8, 9, and 10. An internal cylindrical stop 138 is connected to threaded solid cylinder 119 at a position spaced from inner end portion 124. Also, an external cylindrical stop 140 is connected to threaded solid cylinder 119 at outer end portion 126 of threaded solid cylinder 119.

As discussed previously in relation to FIGS. 7-11, embodiment 142 as shown in FIG. 12 includes eight diode panels 92 are flexibly and biasedly connected to housing 97. Each panel outer arced edge 112 of each diode panel 92 is connected to housing wall 98 at circular rim 102 by two outer springs 134 that are secured both to each panel outer arc edge 112 and to housing wall 98 at housing rim 102 by a suitable means known in the art, for example by hook and ring. Two outer springs 134 are shown for purposes of exposition only and more than two outer springs can be used. Embodiment 142 also shows eight diode panels 92 being flexibly and biasedly connected to cylindrical nut 122. Each panel inner arced edge 114 of each diode panel 92 is connected to cylindrical nut 122 by an inner spring 136.

Connection is made by any suitable means known in the art, for example by hook and ring. More than one inner spring 136 can be used.

As shown in FIG. 12, a cylindrical extension member 146 that includes a cylindrical wall 148 is connected to housing rim 106 in axial alignment with axis 108. Cylindrical extension member 146 defines an extension member outer circular rim 150 that defines a circular outer extension aperture 152 that in turn lies in an extension member rim plane 154 that is perpendicular to axis 108. Extension member rim 150 and extension member rim plane 154 are spaced outwardly from outer end portion 126 and external stop 140. A cylindrical protective lens 156 is mounted to extension member 146 in association with outer extension member outer rim 150 and plane 154 in perpendicular relationship with axis 108. Lens 156 is mounted to extension member outer rim 150 by any suitable means known in the art such as the interior side of rim 150 defining a circular groove 158 into which the circular edge of lens 156 is mounted. A cylindrical axial extension 160 of cylindrical threaded cylinder 119 is connected to outer end portion 126 and extends to an axial extension end 162 that is spaced outwardly from extension member rim plane 154 and lens 156. An outer handwheel 164 is connected to axial extension end 162. Lens 156 defines an axially aligned circular lens aperture 166 that has a lens aperture diameter. Cylindrical axial extension 160 has an axial extension diameter that is less than the lens aperture diameter so that cylindrical axial extension 160 passes through lens aperture 166. An operator can rotate outer handwheel 164 in either a clockwise or counterclockwise direction. When outer handwheel 164 is rotated in a clockwise direction, cylindrical nut 122 is moved axially towards external stop 140 to the position shown in FIG. 11 wherein diode panels 92 are moved to the acute angle mode and diode light beams are moved towards the diverging mode shown in FIG. 11. When outer handwheel 164 as shown in FIG. 12 is rotated in a counterclockwise direction, cylindrical nut 122 is moved axially towards internal stop 138 wherein diode panels 92 are moved to the obtuse angle mode and diode light beams are moved towards the converging mode as shown in FIG. 10. Rotation of outer handwheel 164 in either rotational direction gives the operator the option of moving diode panels 92 to any of a plurality of preselected positions.

Light emitting diodes 12 shown in conduction with diode lighting system 10 and likewise light emitting diodes 90 shown in conduction with diode lighting system 88 can be white light emitting diodes. Light emitting diodes 12 and 90 can also be colored light emitting diodes selected from the group consisting of red, green, and blue light emitting diodes. In addition, light emitting diodes can be light emitting diodes selected from the group consisting of cyan, yellow and magenta.

Basic electrical control of light emitting diodes can be accomplished in three different basic electrical structures or configurations that are set forth in FIGS. 30, 31, 32 and 33 as discussed below. Before proceeding with a discussion of these electrical configurations, a basic comment is as follows. A light emitting diode is a special luminescent semiconductor device that when an adequate amount of forward drive current is passed through the diode, a particular color of light is emitted. This forward drive current is typically 20 milliamperes (20 mA) depending on individual light emitting diode characteristics.

In FIGS. 13, 14, 15 and 16 the following is the legend:  
~ = VAC (Voltage Alternating Current)

V=VDC (Voltage Direct Current)

I=Current

R=Resistance

C=Capacitance

D=Light Emitting Diode

B=Diode Bridge Rectifier

FIG. 13 is an electrical diagram that shows the derivation of a forward current I driving a light emitting diode D by dividing the direct current voltage V by the resistor value, or resistance R, that is,  $I=V/R$ . With a constant voltage value, the resistance R can be selected to produce the necessary forward drive current for light emitting diode D.

FIG. 14 is an electrical diagram that shows alternating current voltage passing through diode bridge rectifier B and becoming direct current voltage V to drive the light emitting diodes D<sub>1</sub>, D<sub>2</sub>, D<sub>3</sub> and D<sub>4</sub>. Resistance R is used to limit the forward drive current I, and the capacitance C is used to smooth out the ripple current of the direct current voltage and make it more constant. The light emitting diodes are connected in series such that the forward drive current is identical in all of the light emitting diodes D<sub>1</sub>, D<sub>2</sub>, D<sub>3</sub> and D<sub>4</sub>. Provided that the light emitting diodes D<sub>1</sub>, D<sub>2</sub>, D<sub>3</sub> and D<sub>4</sub> are the same, the actual voltage V divided by the actual number of light emitting diodes in the series, or in this case, V/4.

FIG. 15 is an electrical diagram that shows light emitting diodes D<sub>1</sub>, D<sub>2</sub>, D<sub>3</sub> and D<sub>4</sub> are now connected in parallel such that each individual light emitting diode receives the same direct current voltage V. The individual forward drive currents are derived as follows for each light emitting diode. For D<sub>1</sub> to D<sub>4</sub>,  $I_1=V/R_1$ ; for D<sub>2</sub>,  $I_2=V/R_2$ ; for D<sub>3</sub>,  $I_3=V/R_3$ ; and for D<sub>4</sub>,  $I_4=V/R_4$ . The total current  $I=I_1+I_2+I_3+I_4$ .

FIG. 16 is an electrical diagram that shows a combination of light emitting diodes connected in both series and parallel. Each series leg is connected in parallel to each other. As in FIG. 15, each series leg sees the same direct current voltage V. The total current  $I=I_1+I_2+I_3+I_4$ . The individual forward drive currents are derived as follows for each light emitting diode: For D<sub>1</sub> to D<sub>4</sub>,  $I_1=V/R_1$ ; for D<sub>5</sub> to D<sub>8</sub>,  $I_2=V/R_2$ ; for D<sub>9</sub> to D<sub>12</sub>,  $I_3=V/R_3$ ; and for D<sub>13</sub> to D<sub>16</sub>,  $I_4=V/R_4$ . Each light emitting diode in the individual series leg sees only a quarter of the overall voltage V. alternating current passing through a diode bridge rectifier B and becoming direct current voltage V to drive the light emitting diodes D<sub>1</sub>, D<sub>2</sub>, D<sub>3</sub> and D<sub>4</sub>.

Four diodes are shown in each of FIGS. 13, 14, 15 and 16 for purposes of exposition only. More or fewer diodes can be used for each example without altering the fundamental derivations.

Added commentary on FIGS. 13, 14, 15 and 16 follows. A fairly direct relationship exists between the forward drive current versus the relative output luminosity for a light emitting diode. The luminous intensity is normally at its maximum at the rated DC forward drive current operating at an ambient temperature of 25 degrees Celsius. When the drive current is less than the rated forward drive current, the output will be correspondingly lower. The described circuit arrangements, therefore, will cause the light emitting diodes to give out a lower light output when the input alternating current voltage is lowered. This makes the light emitting diodes and the related circuitry ideal replacements for existing incandescent filament lamps, because they can be operated with and be dimmed using conventional SCR type wall dimmers.

Likewise, instead of using a constant voltage source to supply current to a circuit containing light emitting diodes,

a pulse forward current can be used. A pulsed forward drive current, as obtained from pulse width modulation circuits with adjustable duty cycles causing the LEDs to provide more drive current, resulting in brighter light outputs. Caution must be used when overdriving the light emitting diodes so as not to overheat the diodes and cause them to burn out prematurely.

The LEDs described herein can be such that produce white light. Colored LEDs can also be used to produce the primary colors red, green, and blue and also yellow and amber/orange. The LEDs described herein also can be multi-chip and multi-LED arrays. Furthermore the LEDs described herein can infrared.

Although the present invention has been described in some detail by way of illustration and example for purposes of clarity and understanding, it will, of course, be understood that various changes and modifications may be made in the form, details, and arrangements of the parts without departing from the scope of the invention set forth in the following claims.

What is claimed is:

1. A diode light source system for stage, theatrical and architectural lighting, comprising

a plurality of separate, rigid flat Panels for mounting a plurality of light emitting diodes that emit a plurality of diode light beams to a common focus area, each said separate panel being mounted with a plurality of grouped diodes of said plurality of diodes, each said separate panel having an outer panel portion and an inner panel portion, wherein said plurality of diodes are oriented perpendicular to said flat panels and emit said diode light beams perpendicular to said flat panels;

a housing for containing said panels, said housing having a center base portion and a circular rim defining a housing aperture aligned with a circular rim plane having a rim plane center arranged transverse to an axis aligned with said center base portion,

first connecting means for flexibly securing each said outer diode panel portion to said rim,

a screw arrangement for positioning said panels at a plurality of selected positions wherein each of said panels is oriented at a selected angle relative to said axis and said grouped diodes emit diode light beams transverse to each said separate panel, wherein said screw arrangement comprises an elongated externally threaded cylindrical nut, said externally threaded cylindrical nut being threadably mounted within said cylindrical nut, said externally threaded cylinder being aligned with said axis, said externally threaded cylinder having opposed inner and outer end portions, said inner end portion being rotatably mounted to said housing at said center base portion and said outer end being spaced outwardly from said circular rim plane, said externally threaded cylinder being aligned with and rotatable about said axis; and

second connecting means for flexibly securing each said inner panel portion to said screw arrangement, and electrical circuit means associated with said panels for transmitting and controlling direct current electrical voltage to said plurality of diodes.

2. The diode light source system in accordance with claim 1, wherein said light emitting diodes are white light emitting diodes.

3. The diode light source system in accordance with claim 1, wherein said light emitting diodes are colored light emitting diodes.

15

4. The diode light source system in accordance with claim 2, wherein said light emitting diodes are light emitting diodes selected from the group consisting of red, green, blue and white light emitting diodes.

5. The diode light source system in accordance with claim 3, wherein said colored light emitting diodes are colored light emitting diodes selected from the group consisting of cyan, yellow and magenta light emitting diodes.

6. A diode light source system for stage, theatrical and architectural lighting, comprising

a plurality of separate flat panels for mounting a plurality of light emitting diodes that emit a plurality of diode light beams to a common focus area, each said separate panel being mounted with a plurality of grouped diodes of said plurality of diodes, each said separate panel having an outer panel portion and an inner panel portion,

a housing for containing said panels, said housing having a center base portion and a circular rim defining a housing aperture aligned with a circular rim plane having a rim plane center arranged transverse to an axis aligned with said center base portion,

first connecting means for flexibly securing each said outer diode panel portion to said rim, wherein said first connecting means is a flexible, biasable outer connecting member having a cylindrical configuration, and said flexible outer connecting member is creased to fold between a normal position in accordance with said normal mode of said panels and to an expanded position in accordance with said acute angle mode of said panels and with said obtuse angle mode of said panels;

a screw arrangement for positioning said panels at a plurality of selected positions wherein each of said panels is oriented at a selected angle relative to said axis and said grouped diodes emit diode light beams transverse to each said separate panel,

second connecting means for flexibly securing each said inner panel portion to said screw arrangement, and

electrical circuit means associated with said panels for transmitting and controlling direct current electrical voltage to said plurality of diodes.

7. The diode light source system in accordance with claim 6, wherein said flat panels are rigid.

8. The diode light source system in accordance with claim 7, wherein in one of said plurality of selected positions, said panels are oriented in a normal panel mode at a 90 degree angle relative to said axis and said diode light beams are oriented parallel relative to said axis wherein said diode light beams are in a normal beam mode.

9. The diode light source system in accordance with claim 7, wherein in one of said plurality of said selected positions, said panels are oriented at a selected common obtuse angle mode relative to said axis wherein said diode light beams are in a converging mode.

10. The diode light source system in accordance with claim 7, wherein in one of said plurality of said selected positions, said panels are oriented at a selected common acute angle mode relative to said axis wherein said diode light beams are in a diverging mode.

11. The diode light source system in accordance with claim 6, wherein said screw arrangement comprises an elongated externally threaded cylinder and a correspondingly internally threaded cylindrical nut, said externally threaded cylinder being threadably mounted.

12. The diode light source system in accordance with claim 11, wherein said panels are of equal size and configuration.

16

13. The diode light source system in accordance with claim 12, wherein each of said panels is generally configured as a wedge.

14. The diode light source system in accordance with claim 13, wherein each said outer portion of said panels is shaped as a panel outer arc and said housing has an arced inner surface, said panel outer arc being conformed with said housing arced inner surface.

15. The diode light source system in accordance with claim 13, wherein each said inner portion of said panels is shaped as a panel inner arc and said cylindrical nut has an arced outer surface, said panel inner arc being conformed with said arced outer surface of said cylindrical nut.

16. A diode light source system for stage, theatrical and architectural lighting, comprising

a plurality of separate flat panels for mounting a plurality of light emitting diodes that emit a plurality of diode light beams to a common focus area, each said separate panel being mounted with a plurality of grouped diodes of said plurality of diodes, each said separate panel having an outer panel portion and an inner panel portion,

a housing for containing said panels, said housing having a center base portion and a circular rim defining a housing aperture aligned with a circular rim plane having a rim plane center arranged transverse to an axis aligned with said center base portion, and said housing defines a concave hollow volume having an inner surface symmetrical with said axis and with said separate diode panels and with each of said plurality of said grouped diodes at each of said plurality of selected positions; and wherein said inner surface is a microreflective surface;

first connecting means for flexibly securing each said outer diode panel portion to said rim,

a screw arrangement for positioning said panels at a plurality of selected positions wherein each of said panels is oriented at a selected angle relative to said axis and said grouped diodes emit diode light beams transverse to each said separate panel,

second connecting means for flexibly securing each said inner panel portion to said screw arrangement, and electrical circuit means associated with said panels for transmitting and controlling direct current electrical voltage to said plurality of diodes.

17. The diode light source system in accordance with claim 16, wherein said screw arrangement comprises an elongated externally threaded cylinder and a correspondingly internally threaded cylindrical nut, said externally threaded cylinder being threadably mounted within said cylindrical nut, said externally threaded cylinder being aligned with said axis, said externally threaded cylinder having opposed inner and outer end portions, said inner end portion being rotatably mounted to said housing at said center base portion and said outer end being spaced outwardly from said circular rim plane, said externally threaded cylinder being aligned with and rotatable about said axis.

18. A diode light source system for stage, theatrical and architectural lighting, comprising

a plurality of separate flat panels for mounting a plurality of light emitting diodes that emit a plurality of diode light beams to a common focus area, each said separate panel being mounted with a plurality of grouped diodes of said plurality of diodes, each said separate panel having an outer panel portion and an inner panel portion, wherein each of said plurality of separate flat diode panels is unitary with a rigid electrical circuit board;

17

a housing for containing said panels, said housing having a center base portion and a circular rim defining a housing aperture aligned with a circular rim plane having a rim plane center arranged transverse to an axis aligned with said center base portion,

first connecting means for flexibly securing each said outer diode panel portion to said rim,

a screw arrangement for positioning said panels at a plurality of selected positions wherein each of said panels is oriented at a selected angle relative to said axis and said grouped diodes emit diode light beams transverse to each said separate panel,

second connecting means for flexibly securing each said inner panel portion to said screw arrangement, and

electrical circuit means associated with said panels for transmitting and controlling direct current electrical voltage to said plurality of diodes.

19. The diode light source system in accordance with claim 18, wherein said first connecting means is a plurality of outer springs.

20. The diode light source system in accordance with claim 18, wherein said second connecting means is a plurality of inner springs.

21. The diode light source system in accordance with claim 18, further including connecting means for holding said plurality of light emitting diodes to said plurality of separate flat diode panels.

22. The diode light source system in accordance with claim 18, wherein said housing defines a concave hollow volume having an inner surface symmetrical with said axis and with said separate diode panels and with each of said plurality of said grouped diodes at each of said plurality of selected positions.

23. A diode light source system for stage, theatrical and architectural lighting, comprising

a plurality of separate flat panels for mounting a plurality of light emitting diodes that emit a plurality of diode light beams to a common focus area, each said separate panel being mounted with a plurality of grouped diodes of said plurality of diodes, each said separate panel having an outer panel portion and an inner panel portion,

a housing for containing said panels, said housing having a center base portion and a circular rim defining a housing aperture aligned with a circular rim plane having a rim plane center arranged transverse to an axis aligned with said center base portion, and said housing defines a concave hollow volume having an inner surface symmetrical with said axis; and said inner surface is a microreflector surface;

first connecting means for flexibly securing each said outer diode panel portion to said rim,

a screw arrangement for positioning said panels at a plurality of selected positions wherein each of said panels is oriented at a selected angle relative to said axis and said grouped diodes emit diode light beams transverse to each said separate panel,

second connecting means for flexibly securing each said inner panel portion to said screw arrangement, and

electrical circuit means associated with said panels for transmitting and controlling direct current electrical voltage to said plurality of diodes.

24. The diode light source system in accordance with claim 23, wherein said screw arrangement comprises an elongated externally threaded cylinder and a correspond-

18

ingly internally threaded cylindrical nut, said externally threaded cylinder being threadably mounted within said cylindrical nut, said externally threaded cylinder being aligned with said axis, said externally threaded cylinder having opposed inner and outer end portions, said inner end portion being rotatably mounted to said housing at said center base portion and said outer end being spaced outwardly from said circular rim plane, said externally threaded cylinder being aligned with and rotatable about said axis.

25. The diode light source system in accordance with claim 23, further including a cylindrical housing extension member connected to said housing rim portion and extending in alignment with said axis and having an extension member circular rim spaced from said housing rim, said extension member circular rim defining an extension member aperture having an extension member aperture plane transverse to said axis and further including a lens having a lens rim connected to said extension member circular rim and positioned in said extension member aperture plane.

26. The diode light source system in accordance with claim 25, wherein said externally threaded cylinder includes a cylindrical extension member aligned with said axis and extending outwardly from said outer end portion, said lens defining a central circular aperture aligned with said axis, said cylindrical extension member being positioned in said circular aperture and having a cylindrical extension member end spaced outwardly from said lens.

27. The diode light source system in accordance with claim 26, further including an extension member handwheel connected to said cylindrical extension member end.

28. A diode light source system for stage, theatrical and architectural lighting, comprising

a plurality of separate flat panels for mounting a plurality of light emitting diodes that emit a plurality of diode light beams to a common focus area, each said separate panel being mounted with a plurality of grouped diodes of said plurality of diodes, each said separate panel having an outer panel portion and an inner panel portion,

a housing for containing said panels, said housing having a center base portion and a circular rim defining a housing aperture aligned with a circular rim plane having a rim plane center arranged transverse to an axis aligned with said center base portion, said housing defines a concave hollow volume having an inner surface symmetrical with said axis; and said inner surface is a microreflector surface;

first connecting means for flexibly securing each said outer diode panel portion to said rim,

a screw arrangement for positioning said panels at a plurality of selected positions wherein each of said panels is oriented at a selected angle relative to said axis and said grouped diodes emit diode light beams transverse to each said separate panel,

second connecting means for flexibly securing each said inner panel portion to said screw arrangement, said second connecting means is a flexible, biasable inner connecting member having a cylindrical configuration, and said flexible inner connecting member is creased to fold between a normal position in accordance with said normal mode of said panels and to an expanded position in accordance with said acute angle mode of said panels with said obtuse angle mode of said panels; and

electrical circuit means associated with said panels for transmitting and controlling direct current electrical voltage to said plurality of diodes.

29. The diode light source system in accordance with claim 28, wherein said first connecting means is at least one outer spring.

30. The diode light source system in accordance with claim 29, wherein said first connecting means is a plurality of outer springs.

31. The diode light source system in accordance with claim 28, wherein said screw arrangement comprises an elongated externally threaded cylinder and a correspondingly internally threaded cylindrical nut, said externally threaded cylinder being threadably mounted within said cylindrical nut, and externally threaded cylinder being aligned with said axis, said externally threaded cylinder having opposed inner and outer end portions, said inner end portion being rotatably mounted to said housing at said center base portion and said outer end being spaced outwardly from said circular rim plane, said externally threaded cylinder being aligned with and rotatable about said axis.

32. The diode light source system in accordance with claim 31, wherein said plurality of diodes are oriented perpendicular to said flat panels and emit said diode light beams perpendicular to said flat panels.

33. The diode light source system in accordance with claim 31, wherein said second connecting means flexibly secures each of said inner panel portions to said cylindrical nut.

34. The diode light source system in accordance with claim 31, wherein said inner end portion of said externally threaded cylinder is positioned external to said housing at said center base portion, and further including a handwheel connected to said inner end portion.

35. The diode light source system in accordance with claim 31, further including an outer stop member connected to said outer end portion of said externally threaded cylinder.

36. The diode light source system in accordance with claim 31, further including an inner stop member connected to said externally threaded cylinder spaced from said inner end portion.

37. The diode light source system in accordance with claim 28, wherein said second connecting means is at least one inner spring.

38. The diode light source system in accordance with claim 37, wherein said at least one inner spring is a plurality of inner springs.

39. The diode light source system in accordance with claim 37, wherein said at least one inner spring is a plurality of inner springs.

40. The diode light source system in accordance with claim 39, wherein said plurality of inner springs is a plurality of inner coil springs.

41. A diode light source system for stage, theatrical and architectural lighting, comprising

a plurality of separate flat panels for mounting a plurality of light emitting diodes that emit a plurality of diode light beams to a common focus area, each said separate panel being mounted with a plurality of grouped diodes of said plurality of diodes, each said separate panel having an outer panel portion and an inner panel portion, and wherein each said panel is a combined mounting board for holding said group of diodes and an electrical circuit board; wherein each said panel has opposed flat sides, one side functioning as said mounting board and the opposed side functioning as said circuit board having electrical circuitry for operating said group of diodes and wherein said combination mounting board and circuit board is rigid;

a housing for containing said panels, said housing having a center base portion and a circular rim defining a

housing aperture aligned with a circular rim plane having a rim plane center arranged transverse to an axis aligned with said center base portion,

first connecting means for flexibly securing each said outer diode panel portion to said rim,

a screw arrangement for positioning said panels at a plurality of selected positions wherein each of said panels is oriented at a selected angle relative to said axis and said grouped diodes emit diode light beams transverse to each said separate panel,

second connecting means for flexibly securing each said inner panel portion to said screw arrangement, and

electrical circuit means associated with said panels for transmitting and controlling direct current electrical voltage to said plurality of diodes.

42. The diode light source system in accordance with claim 41, wherein said first connecting means is a flexible outer connecting member having a cylindrical configuration.

43. The diode light source system in accordance with claim 42, wherein said flexible outer connecting member is biasable.

44. The diode light source system in accordance with claim 41, wherein said screw arrangement comprises an elongated externally threaded cylinder and a correspondingly internally threaded cylindrical nut, said externally threaded cylinder being threadably mounted within said cylindrical nut, said externally threaded cylinder being aligned with said axis, said externally threaded cylinder having opposed inner and outer end portions, said inner end portion being rotatably mounted to said housing at said center base portion and said outer end being spaced outwardly from said circular rim plane, said externally threaded cylinder being aligned with and rotatable about said axis.

45. The diode light source system in accordance with claim 44, wherein said plurality of diodes are oriented perpendicular to said flat panels and emit said diode light beams perpendicular to said flat panels.

46. The diode light source system in accordance with claim 45, wherein said flat panels are rigid.

47. The diode light source system in accordance with claim 41, wherein said first connecting means is a plurality of outer springs.

48. The diode light source system in accordance with claim 41, wherein said second connecting means is a plurality of inner springs.

49. The diode light source system in accordance with claim 41, wherein said light emitting diodes are selected from the group consisting of red, green, blue, white, cyan, yellow, magenta and combinations thereof.

50. The diode light source system in accordance with any one of claims 1, 11, 33, 23, or 43, wherein said second connecting means flexibly secures each of said inner panel portions to said cylindrical nut.

51. The diode light source system in accordance with any one of claims 1, 11, 33, 23 or 43, wherein said inner end portion of said externally threaded cylinder is positioned external to said housing at said center base portion, and further including a handwheel connected to said inner portion.

52. The diode light source system in accordance with any one of claims 1, 11, 33, 23 or 43, further including an outer stop member connected to said outer end portion of said externally threaded cylinder.

53. The diode light source system in accordance with any one of claims 1, 11, 33, 23 or 43, further including an inner stop member connected to said external threaded cylinder spaced from said inner end portion.

**21**

**54.** The diode light source system in accordance with any one of claims **1, 11, 28, 16, 18, 23** or **41**, wherein in one of said plurality of selected positions, said panels are oriented in a normal panel mode at a 90 degree angle relative to said axis and said diode light beams are oriented parallel relative to said axis wherein said diode light beams are in a normal beam mode.

**55.** The diode light source system in accordance with any one of claims **1, 11, 28, 16, 18, 23** or **41**, wherein in one of said plurality of said selected positions, said panels are

**22**

oriented at a selected common obtuse angle mode relative to said axis wherein said diode light beams are in a converging mode.

**56.** The diode light source system in accordance with any one of claims **1, 11, 28, 16, 18, 23** or **41**, wherein in one of said plurality of said selected positions, said panels are oriented at a selected common acute angle mode relative to said axis wherein said diode light beams are in a diverging mode.

\* \* \* \* \*