

FIG. 1

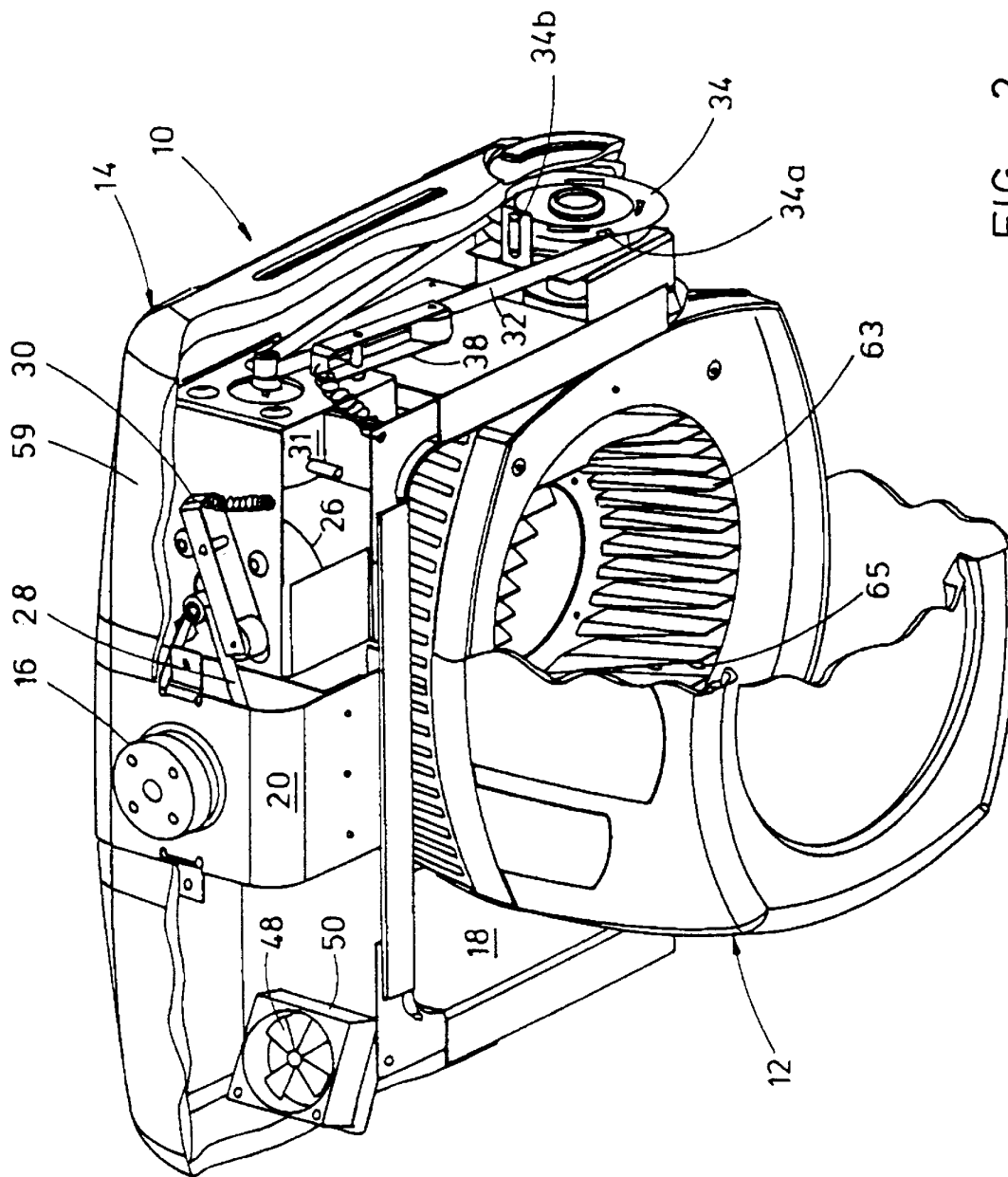
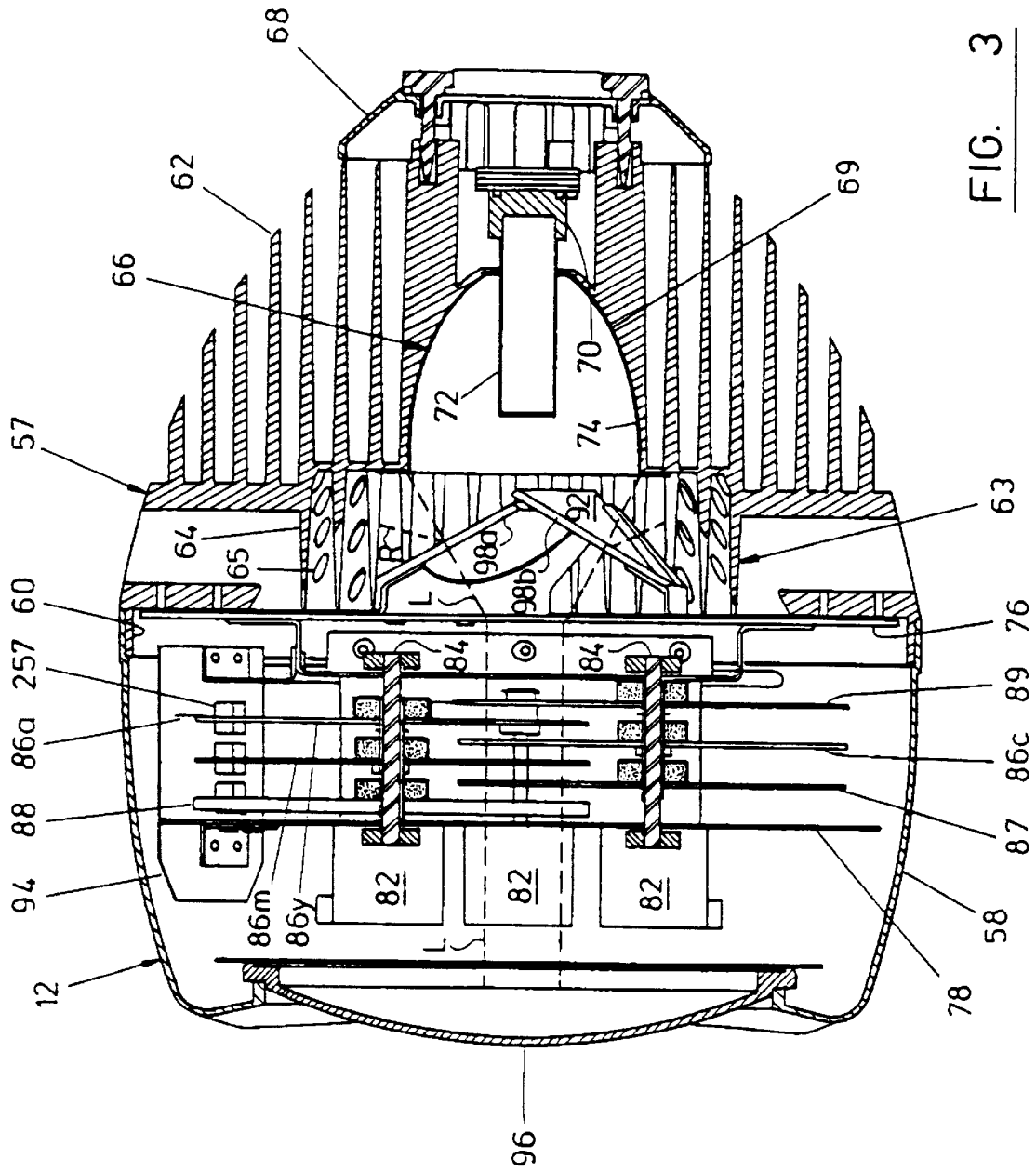

FIG. 2



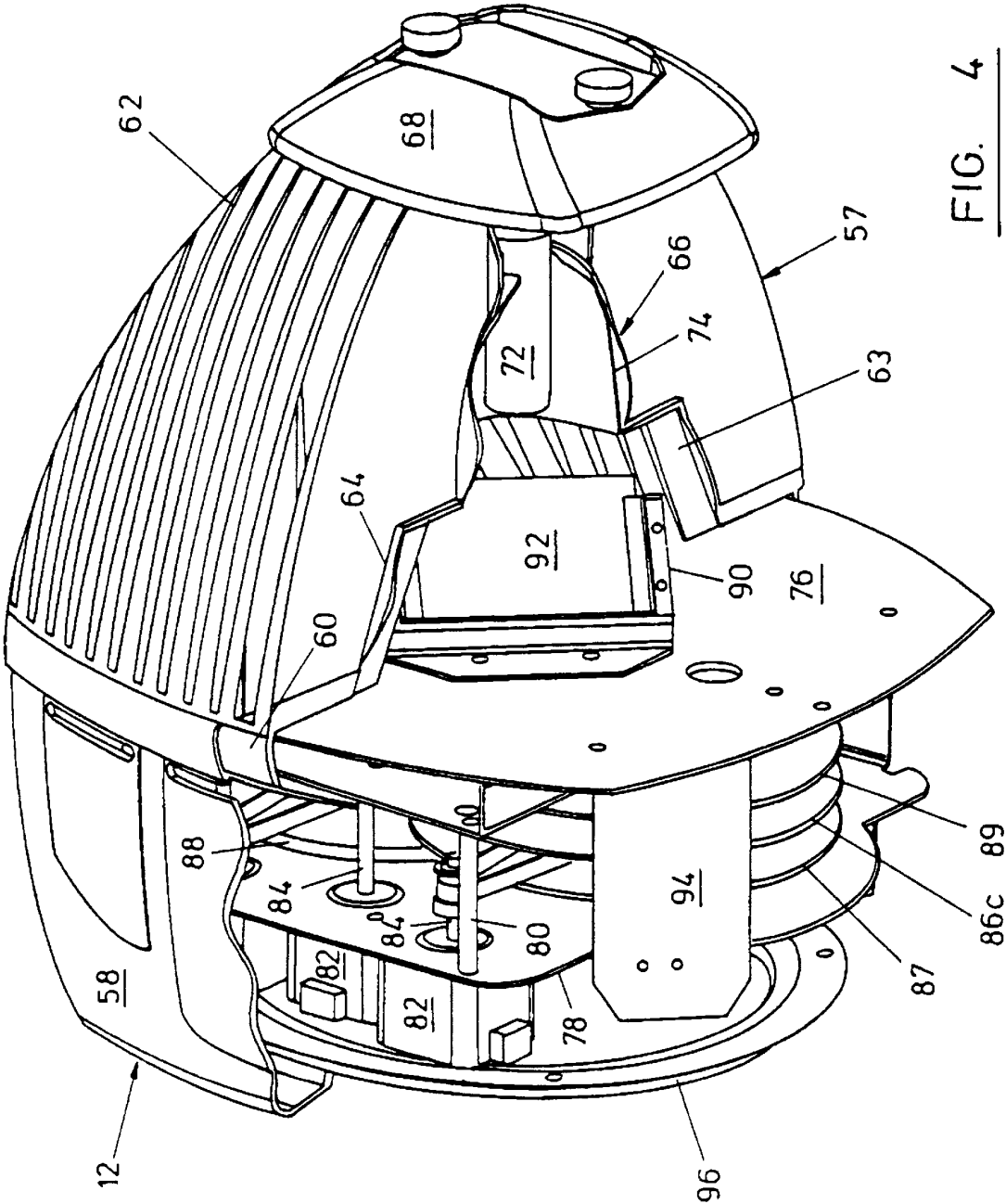
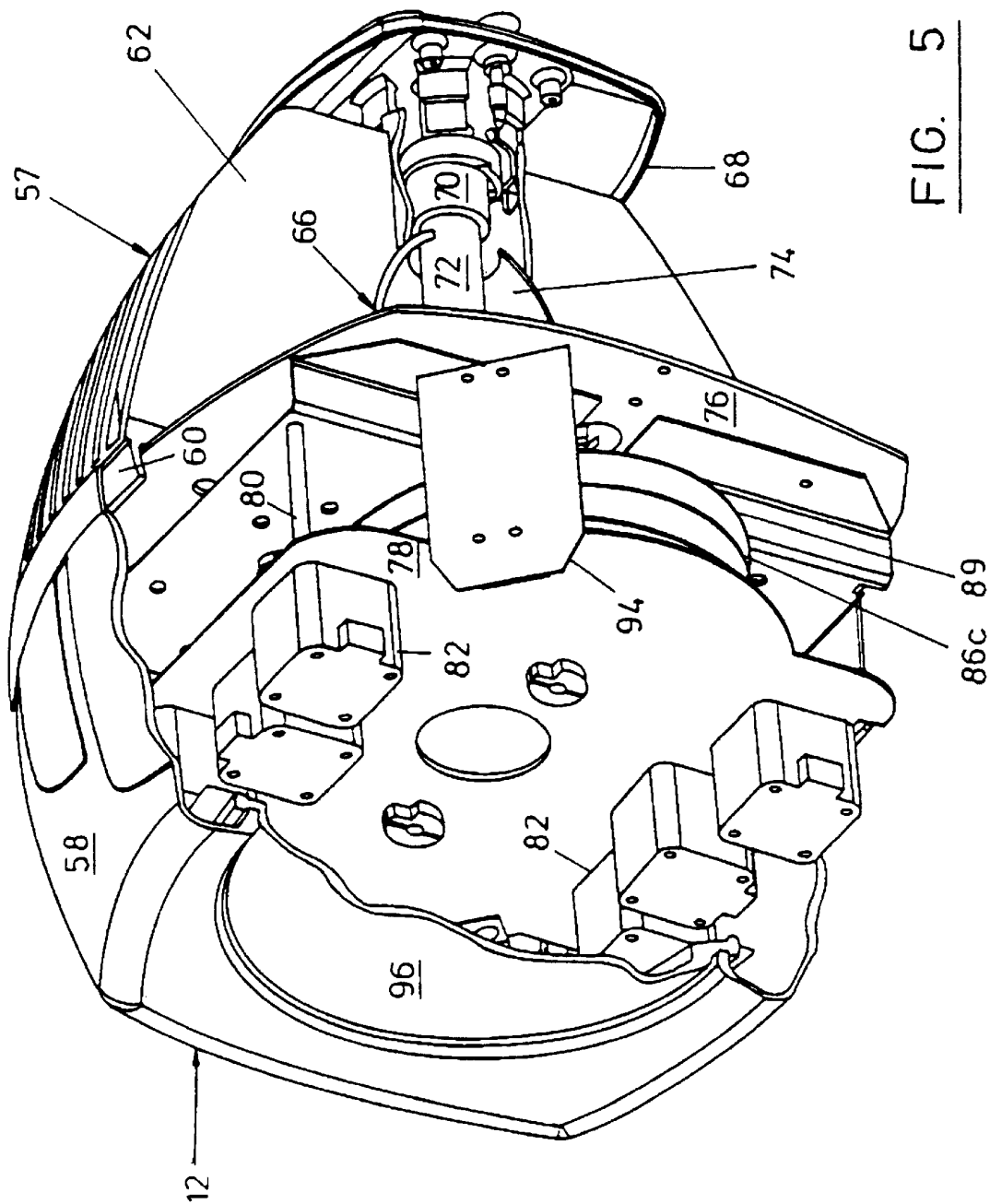

FIG. 4



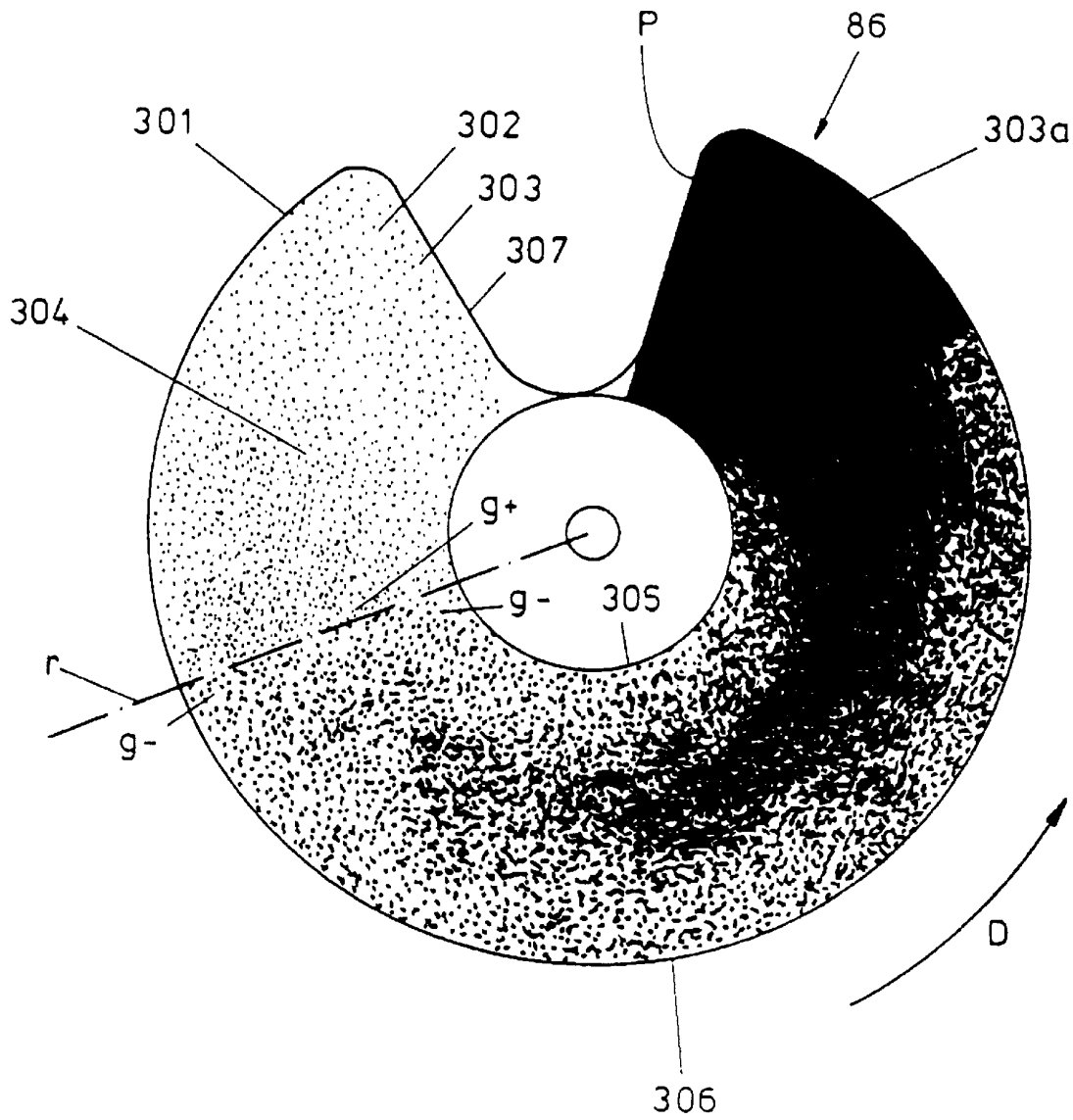

FIG. 6

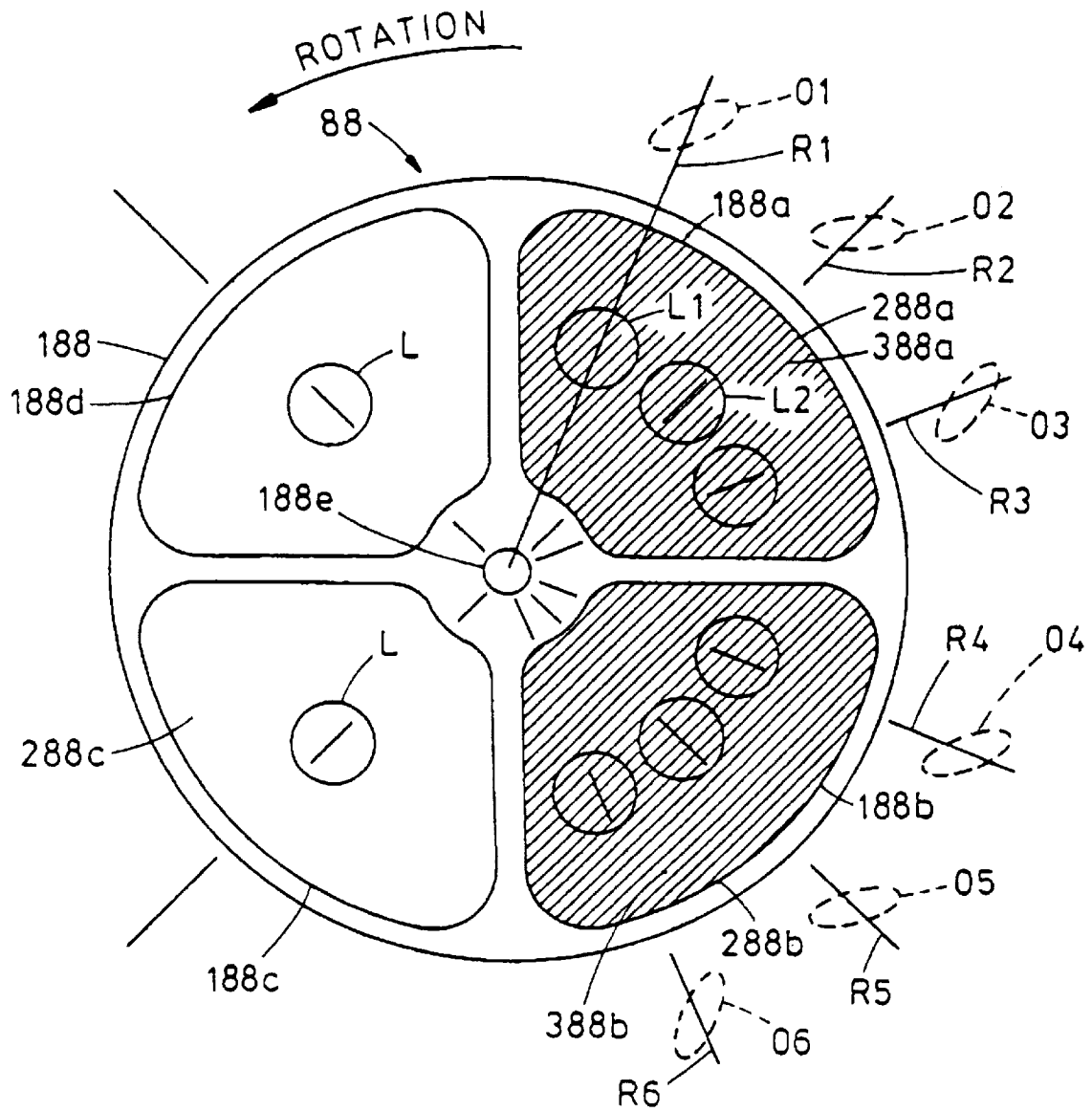

FIG. 7A

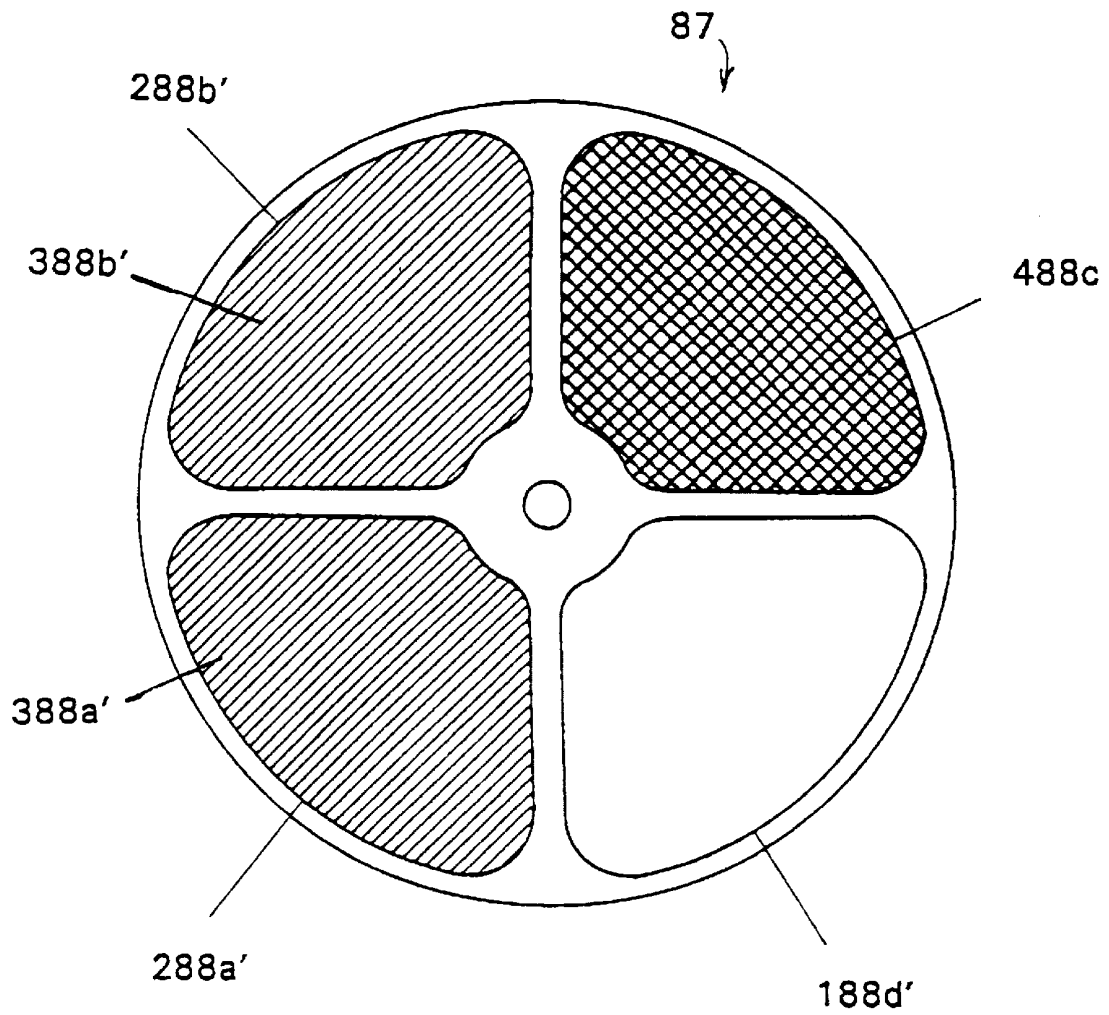

FIG. 7B

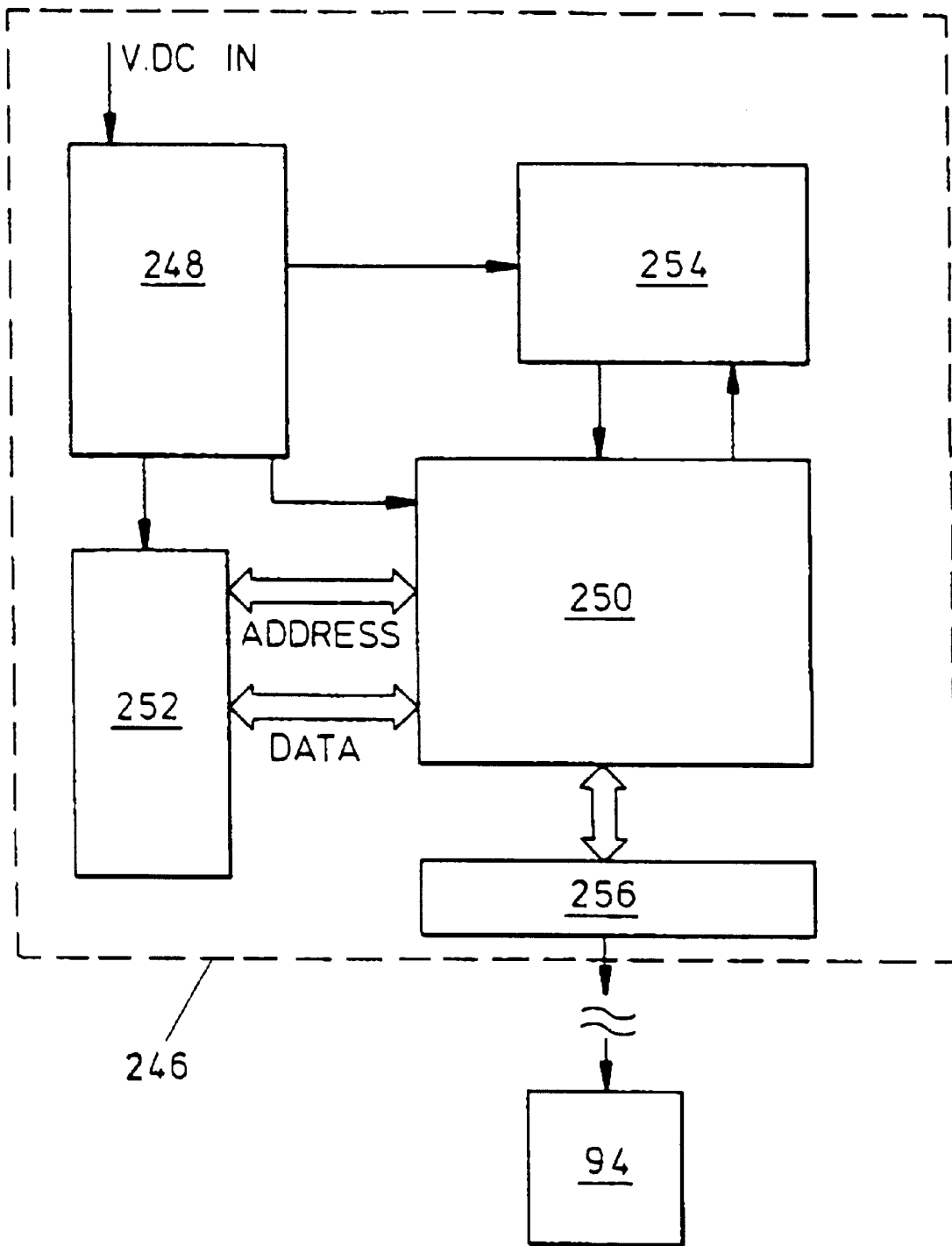

FIG. 9

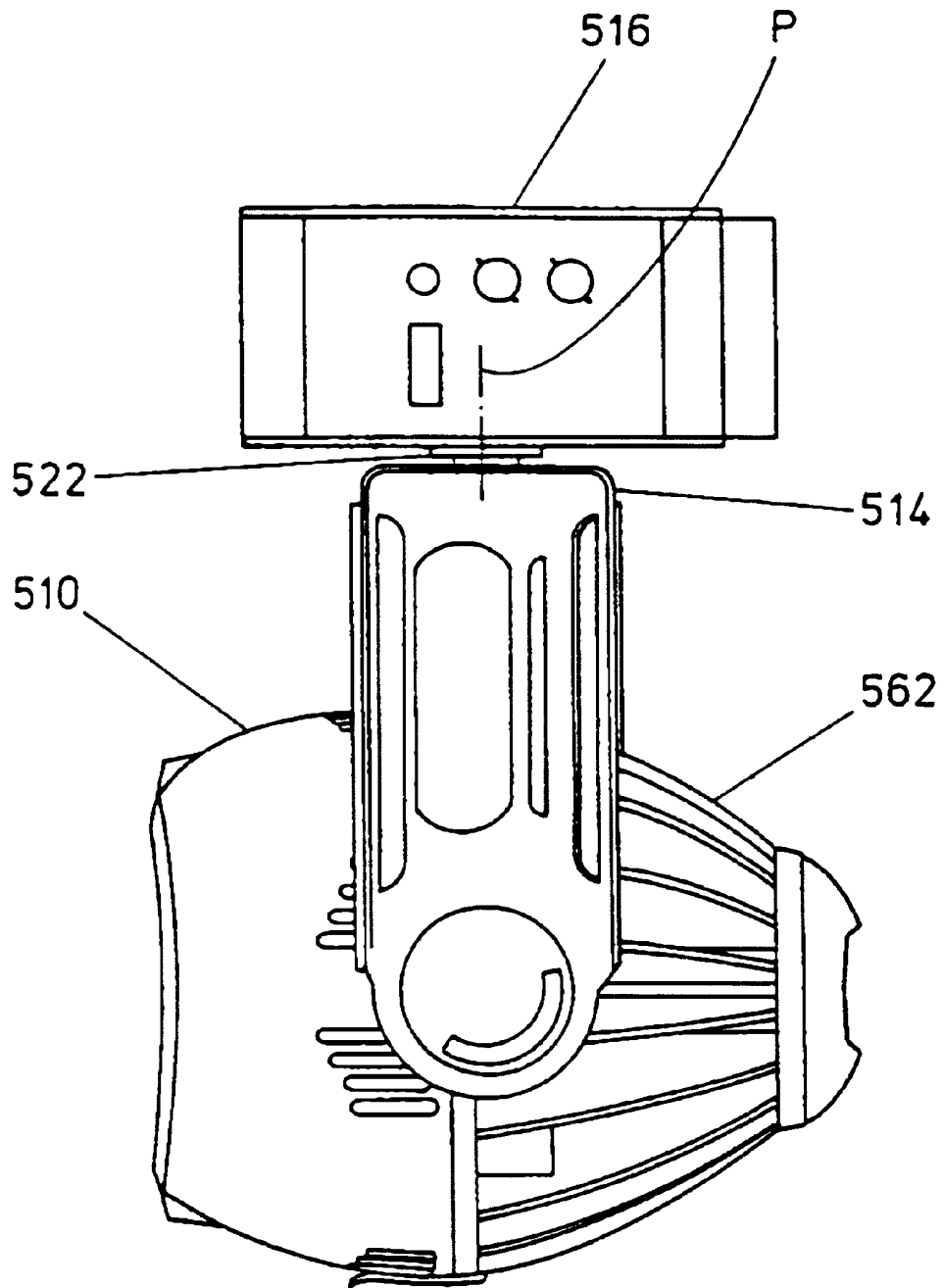

FIG. 10

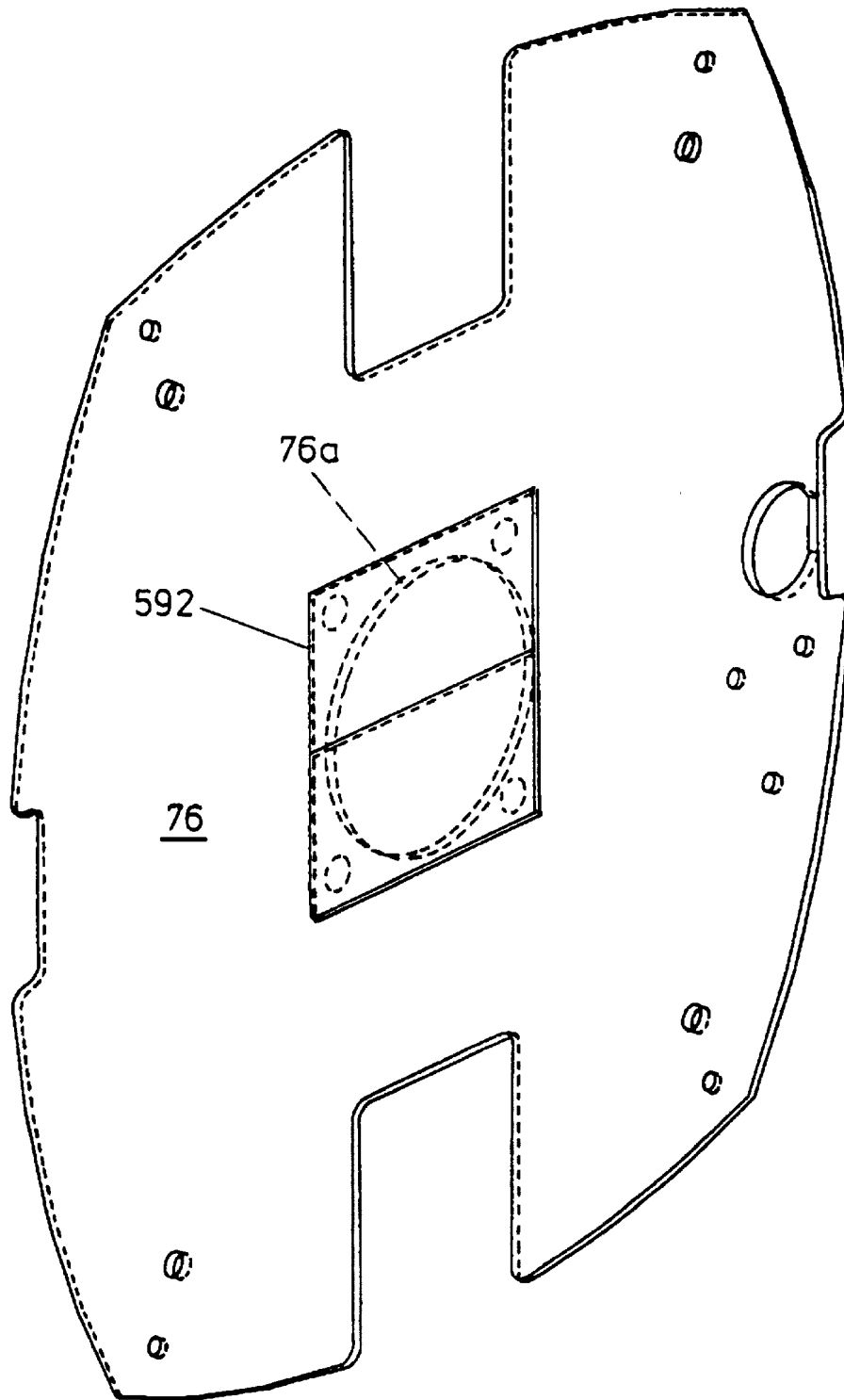

FIG. 11

LIGHTING SYSTEM WITH MULTIPLE BEAM SHAPES

FIELD OF THE INVENTION

This invention relates generally to stage and theater lighting fixtures and more particularly to a color wash luminaire which provides variable intensity, variable color, variable positioning and variable beam shapes and angles in a single compact fixture.

BACKGROUND OF THE INVENTION

Wash lights, as they are generally known, are used to provide uniform illumination and coloration to a theatrical set. Lights used in a studio or for photographic purposes often project a round cross-sectional pattern of light such as that seen by the ordinary flashlight. Simple devices utilize a reflector and a lamp or utilize sealed beam lamps, such as automotive head light type lamps. These sealed lamps consist of a reflector, a lamp and a type of diffuser or lens to soften the projected spot, and sometimes to focus the projected spot from either a narrow spot or a wide flood. More complicated arrangements involve ellipsoidal reflectors or condensing systems which focus light through an aperture which is imaged by projector lenses.

These types of systems commonly produce a more uniform beam of light than that of the sealed beam type. Other types of lights used include fresnel projectors, which utilize a fresnel projecting lens. The fresnel projecting lens is known to provide a beam of light that is homogenous with a gradual rolloff of light output toward the edges. Many of the things illuminated on a stage of studio do not always require a round beam of light since many stages or studio sets can often be more wide than they are tall. Illuminated subject areas often require the use of a framing projector or devices known as barn doors which can be utilized to change cross-sectional pattern or the shape of the beam by shadowing the light projected from the device as a means to change the shape of the beam.

The foregoing illustrates limitations of the known prior art. Thus it is apparent that it would be advantageous to provide alternatives directed to overcoming one or more of the limitations as set forth above. Accordingly, suitable alternatives are provided including features and benefits more fully disclosed hereinafter.

SUMMARY OF THE INVENTION

In one aspect of the present invention this is accomplished by providing overlapping lenses for use in a light fixture provided to project a beam of light. The beam projects a first beam shape having a first cross-sectional geometry. A first lens device including at least one lenticular lens element, is supported in the fixture and is movable into a position to interrupt the beam of light for altering the first projected beam shape from the first cross-sectional geometry to a second projected beam shape having a second cross-sectional geometry different from the first geometry. A second lens device, separate from the first lens device and including another lenticular lens element overlapping the one lenticular lens element of the first lens device, is supported in the fixture and is movable into a position to interrupt the beam of light for altering the second projected beam shape from the second cross-sectional geometry to a third projected beam shape having a third cross-sectional geometry different from the first and second geometries.

In another aspect of the present invention, this is accomplished by providing a light fixture including the overlap-

ping lenses. The light fixture may be a moving light fixture and may be of the type including a yoke and means for movably suspending the yoke from a support. A housing is movably connected to the yoke and has a portion including a light source and means for removing heat generated from the light source. Another portion includes a plurality of movable color filters and the overlapping lenses, the light source being operable to project a beam along a path through the color filters and the lens devices. One of the lenses includes a lenticular lens element having a plurality of lenticules oriented in a first direction and the other of the lenses includes a lenticular lens element having a plurality of lenticules oriented in a second direction, different from the first direction.

In a further aspect of the present invention, this is accomplished by providing a light fixture having multiple lens apparatus for changing a shape projected by a beam of light comprising means for projecting a circular beam of light, and overlapping lens devices each including a lenticular lens element movable into a position to interrupt the beam of light for selecting beam shape by altering a circular beam pattern to ellipsoidal beam patterns and for moving the ellipsoidal beam patterns to a desired orientation.

The foregoing and other aspects will become apparent from the following detailed description of the invention when considered in conjunction with the accompanying drawing figures. It is to be expressly understood, however, that the figures are not intended as a definition of the invention but are for the purpose of illustration only.

BRIEF DESCRIPTION OF THE DRAWING FIGURES

FIG. 1 is a frontal view, with partial cutaway portions, illustrating an embodiment of the luminaire of this invention;

FIG. 2 is a perspective view, with partial cutaway portions, illustrating an embodiment of the luminaire of this invention;

FIG. 3 is a cross-sectional view, illustrating an embodiment of the housing of this invention;

FIG. 4 is a perspective view, with partial cutaway portions, illustrating an embodiment of the housing of this invention;

FIG. 5 is another perspective view, with partial cutaway portions, illustrating an embodiment of the housing of this invention;

FIG. 6 is a plan view illustrating an embodiment of the color filter of this invention;

FIG. 7A is a planar view illustrating an embodiment of the rotatable lenticular lens device of this invention;

FIG. 7B is a planar view illustrating an embodiment of another rotatable lenticular lens device of this invention;

FIG. 8 is a diagrammatic view illustrating an embodiment of the power board of this invention;

FIG. 9 is a diagrammatic view illustrating an embodiment of the logic board of this invention;

FIG. 10 is a side elevation view illustrating another embodiment of the luminaire of this invention; and

FIG. 11 is a perspective view illustrating an embodiment of the hot plate and ultra violet filter of this invention;

DETAILED DESCRIPTION OF THE INVENTION

This invention includes overlapping rotating lens devices each including lenticular lens elements movable into a

position to interrupt the beam of light for selecting beam shape by altering a circular beam pattern to ellipsoidal beam patterns and for moving the ellipsoidal beam patterns to a desired orientation.

Referring now to the drawings, FIGS. 1 and 2 illustrate the wash luminaire of the present invention, generally designated 10. Luminaire 10 comprises a housing 12 connected to a yoke 14 which may be suspended from a supporting truss (not shown) by means of a clamp (also not shown) attached to yoke 14 at connector 16.

Yoke 14 comprises a suitable metal frame 18 including a metal bracket 20 to reinforce yoke 14. Connector 16 is bearing mounted and connected by means of a shaft 22 to a gear 24 positioned adjacent bracket 20. Gear 24 includes a notch (not shown) which operates with an adjacent position sensor (not shown) for pan position control. A motor 26, supported by frame 18, drives belt 28 to rotate gear 24 for the purpose of providing a 360 degree rotation about the centroidal axis P of shaft 22. This provides the pan capability to luminaire 10. A suitable idler arrangement 30 is provided to engage belt 28.

Another motor 31, also supported by frame 18, drives belt 32 to rotate gear 34 for the purpose of providing at least a 270 degree rotation about the centroidal axis T of a shaft 36. Similar to gear 24, gear 34 includes a notch 34a which operates with an adjacent position sensor 34b for tilt position control. This provides the tilt capability to luminaire 10. Another suitable idler arrangement 38 is provided to engage belt 32. A travel stop 37 is connected to the tilt mechanism to limit movement of luminaire 10 to a desired tilt angle.

A manual off-on switch or breaker 52 is also mounted externally on yoke 14. A cooling fan 48 mounted in a housing 50 is operable to draw cooling air into yoke 14 through a plurality of vents 54, across the internal components of yoke 14, and outwardly through a similar plurality of vents 56. A cover 59, formed of a rigid synthetic material, which includes vents 54 and 56, encloses yoke 14 and the above described components.

In FIGS. 3, 4, and 5, housing 12 is illustrated and generally comprises an aluminum casting 57 and a bezel 58, formed of a suitable rigid synthetic material. Casting 57 includes a base 60, at a first end, from which a first plurality of contoured external cooling fins 62 extend. A stepped annular relief 66 is provided within casting 57 and includes an annular portion 64 and a truncated elliptical portion 69. Annular portion 64 also includes cooling vents 65. A second plurality of internal cooling fins 63 are disposed about an inner annular periphery of annular portion 64. First and second fins 62, 63, respectively, are aligned.

An aluminum end cap 68 is mounted on a second end of casting 57. A lamp base 70 and lamp 72 are mounted on end cap 68. Lamp 72 extends into open annular relief 66. An elliptical reflector 74 is also mounted in elliptical portion 69 so as to suitably surround lamp 72. Lamp 72 is powered by AC power in a conventional manner.

An aluminum heat blocking wall, or hot plate 76, is mounted on the first end of casting 57, and is spaced from a motor mounting plate 78 by spacer elements 80. A plurality of motors 82 are mounted on motor mounting plate 78 and rotating shafts 84, extending from motors 82, are operable to be belt driven to rotate a plurality of staggered colored filters 86, a pair of overlapping, staggered lenses 87, 88 and a conventional color wheel 89. Tabs, such as tab 86a, on color filter 86, are provided on these shaft mounted, rotating lenses, filters, etc., to operate with a plurality of respective adjacent position sensors 257 mounted on a pair of motor/

driver sensor boards 94 mounted between plates 76, 78 for the purpose of sensing the positions of each of the shaft mounted rotating devices including color filters 86, etc.

Light beam L, FIG. 3, is condensed to a diameter of about 1.25 inches in diameter where it exits casting 57 at an opening 76a in hot plate 76. The beam then passes through the series of wheels; color filters, lens, etc. In the embodiment of FIG. 3, bezel 58 houses a series of 6 wheels. Color wheel 89, dichroic coated color filter (yellow) 86y, dichroic coated color filter (cyan) 86c, dichroic coated color filter (magenta) 86m, and lenses 87 and 88. Three of these wheels are mounted on shaft 84 and another three are mounted on a corresponding shaft 84. The 2 sets of 3 wheels are interleaved, i.e. partially overlapped, in known fashion, to optimize the number of surfaces exposed to beam L. The positions of the three wheels on one shaft 84 are sensed by their respective sensors 257 on one of the boards 94, and the positions of the other three wheels on the other shaft 84 are similarly sensed by their respective sensors 257.

Color filters 86y, 86c and 86m, FIG. 6 comprise a disc-shaped borosilicate glass substrate 301 having a planar surface 302 which includes a photolithographically etched film 303 deposited thereon. Film 303 forms a Gaussian pattern arcuate band 304 extending around a substantial portion of planar surface 302. Band 304 has an inner edge 305 and an outer edge 306 and the density of film 303 is greater in an area designated g+ along a radius r between inner edge 305 and outer edge 306 and less in an area designated g- along radius r at inner edge 305 and less in a corresponding area g- along radius r at outer edge 306. A portion of substrate 301 is cut away to form a notch 307 which interrupts arcuate band 304. A portion p of planar surface 302 adjacent notch 307 is coated with a solid film 303a having no pattern as on the etched film 303 in band 304.

Color filters 86y, 86c and 86m are used in combination with lamp 72 to produce desired color effects. Beam L, produced by lamp 72, is circular and has a typical power gradient, which is not uniform across the beam. A ratio of power from the center of the beam to beam edge is often on the order of 50%. Known variable density filters which do not address the power gradient of the beam, produce results which are non-uniform and leave an apparent white spot in the center of the beam while darkening the beam edge which makes the coloration objectionable.

Advantageously, the Gaussian patterning of the color filters of this invention is coincident with the inverse of the power gradient of the beam L. That is, the color filter gradient is greatest toward the center of the band 304 where it crosses the maximum power point of the beam L. In this manner, the maximum power of the beam L is coincident with the maximum filtering effect of filters 86y, 86c and 86m.

Saturation of the Gaussian color pattern increases proportionally as the filter is rotated in a direction represented by directional arrow D, FIG. 6, culminating in 100% saturation at about 300 degrees of angular travel where portion p of planar surface 302 is coated with solid film 303a.

If it is desired, a bracket 90 is mounted on hot plate 76 to position a heat filter 92 to reflect IR radiation R back to the cooling fins 63, 62 to be dissipated from housing 12. Heat filter 92 comprises the bracket 90, FIGS. 3 and 4, which is generally of an A-frame construction and includes a first filter 98a mounted at about a ninety degree angle relative to a second filter 98b. Filter 92 is used to reflect damaging infrared radiation R away from the previously mentioned

heat sensitive optical components mounted on shafts **84**. Thus, these filters are at an angle to light beam L passing therethrough. The result is a reflection of IR radiation outwardly toward the fins, as is best shown in FIG. **3**. First and second filters **98a**, **98b**, respectively are preferably formed of a suitable 1.75 mm thick substrate of borosilicate glass material and has a thin film dichroic coating on both sides. The coating on one side facing lamp **72**, will provide infrared reflectance of from about 730 nm to about 1,050 nm. The coating in the opposite side will provide reflectance of from about 1,050 nm to about 1,700 nm.

Heat filter **92** can be eliminated. However, preferably a filter for blocking ultra violet rays from reaching the color wheels and their drive systems may be utilized. Such a filter **592**, FIG. **11**, may take the form of a borosilicate glass material positioned between the lamp and the color wheels. For example, the filter **592** may be suitably mounted on the hot plate **76** in place of heat filter **92** in position to filter light beam L before it passes through opening **76a** in hot plate **76**.

A lenticular lens device **88**, FIG. **7A** is rotatably mounted adjacent one side of motor mounting plate **78**. Lens device **88** is mounted on one of the shafts **84** which is rotatably driven by one of the motors **82** suitably attached on another side of motor mounting plate **78**. Lens device **88** comprises a disc shape and is formed of an aluminum or other suitable metal retainer **188** having a plurality of openings **188a**, **188b**, **188c**, **188d** formed therein. An aperture **188e** in the geometric center is for receiving shaft **84** whereby lens device **88** is rotatable. One of the openings **188a** includes a lenticular lens element **288a** formed of a suitable high temperature glass having a plurality of substantially parallel radially extending grooves or lenticules **388a** formed therein. Another of the openings **188b** includes substantially the same lenticular lens element **288b** but having the grooves or lenticules **388b** oriented at 90 degrees relative to lenticules **388a**. Lenticular lens elements **288a** and **288b** will change the geometric shape from a circular to an elongated ellipsoidal shape. Still another of the openings **188c** includes either a suitable well know frost material **288c**, FIG. **7A**, which will diffuse and soften the beam L and spread out the beam angle but will not affect the geometric shape of the beam. The last of the openings **188d** remains open and contains no lens element so that the light beam passing there through retains its normal lights pattern having a circular cross-sectional geometry. The lens elements **288a**, **288b**, **288c** or **488c** may be fixedly secured to retainer **188** by a suitable high temperature silicone based adhesive or may be removably secured by some suitable attachment device.

Another lenticular lens device **87**, FIG. **7B** is rotatably mounted similar to device **88** but staggered to overlap device **88**. Lens device **87** is similar in construction to device **88** except that a homogeneous lens element **488c** is provided in place of the frost material **288c** of device **88**. As it is known, the homogeneous lens element **488c** includes an array of adjacent convex surfaces which function to change the magnification and increase the beam angle but will not affect the geometric shape of light beam L. As a result, lens device **87** includes a lenticular lens element **288a'** having a plurality of substantially parallel radially extending grooves or lenticules **388b'** formed therein and lenticular lens element **288b'** having grooves or lenticules **388b'** oriented at 90 degrees relative to lenticules **388a'**. Homogeneous lens element **488c** is provided instead of frost and **188d'** remains open.

In FIGS. **7A** and **7B** lens devices **87**, **88** are illustrated. When the device **88** is mounted in fixture **10** for rotation on shaft **84** engaged in aperture **188e**, a fixed beam of light L

passes through lens device **88** as the device **88** is rotated. When opening **188d** is in the path of beam L, there is no affect on the beam since there is no lens in opening **188d**. When device **88** is rotated to a position where frosted lens **288c** interrupts beam L, the beam angle is affected but the geometric shape of beam L is unchanged. However, when lenticular lens elements **288a** and/or **288b** interrupt the beam L, the normally projected circular geometric shape of beam L is changed to an oblong or ellipsoidal shape O as illustrated in phantom in FIG. **7A**. Furthermore, as the lens device **88** is rotated through fixed beam L, the oblong shape of beam O changes in orientation.

For purposes of illustration only, several radii are shown in FIG. **7A** and extend outwardly through six different positions where rotating lens device interrupts fixed beam L. In a first position the orientation of altered beam O1 on radius R1 is aligned with the direction of lenticules **388a** as they extend across beam L1 which remains fixed. As viewed in FIG. **7A**, the oblong projected beam O1 is slightly canted to the right with reference to radius R1. In a second position, the orientation of altered beam O2 on radius R2 is aligned with the direction of lenticules **388a** as they extend across fixed beam L2 which is actually in the same fixed position as the beam designated L or L1. As viewed in FIG. **7A**, the longitudinal axis of the projected beam O2 is vertically aligned with reference to radius R2 and as the lens device **88** is further rotated, the oblong projected beam O3, O4, O5 and O6 constantly changes orientation in the direction of rotation with reference to its respective radii R3, R4, R5 and R6 due to the changing orientation of lenticules **388a** and **388b** extending across the fixed light beam.

With the foregoing orientation description in mind, it can be appreciated that the overlapping lens devices **87**, **88** provide a wide variety of beam shapes including combinations of beam shapes heretofore not available. The combinations include circular and ellipsoidal beam shapes with or without frost, with or without increased beam angle, or with overlapping ellipsoidal beam shapes, for example where lens element **288a** overlaps lens element **288b'** wherein the ellipsoidal beam shape provided by one lenticular lens element, i.e. **288a**, can extend in a longitudinal direction which is angularly disposed relative to the longitudinal direction of the ellipsoidal beam shape provided by another lenticular lens element, i.e. **288b'**, of an overlapping lens device. This unique combination provides enhanced lighting effects not previously available.

Also included in yoke **14** is a power supply board **146**, best shown in FIG. **8**, mounted behind a portion designated **46** of metal frame **18**. Power supply board **146** is the motor and logic power supply for movement of luminaire **10**. Power supplied to board **146** may be 100 to 240 VAC (50/60 Hz). A voltage selection rectification **148**, changes AC to DC voltage and operates to double the voltage if less than 150 VAC. Output is stored in capacitors **150**, **151** and then a half bridge **152** switches the DC back to AC voltage at 40 kHz. The 40 kHz goes into a transformer **154** which steps the voltage down and isolates the live voltage from the low voltage output circuit. The AC voltage is rectified back to DC voltage and filtered via an inductor-capacitor arrangement at **156**. A voltage mode, pulse width modulator controller **158** is responsible for the feedback of the output voltage and controls the half bridge **152** to produce a constant output voltage. Also, a voltage sensor for doubler circuit control is provided at **160**.

A logic board **246**, best shown in FIG. **9**, is mounted in yoke **14** behind a portion designated **40**, of metal frame **18**. The logic board is operably connected to a controller and

controls the above-mentioned pan and tilt, and also controls color wheels, etc., and other operable components of the luminaire 10. Power from power board 146 is fed to logic board 26 at from about 9VDC to about 40VDC through a voltage regulator circuit 248. The power is then communicated to a commercially available embedded microprocessor 250. The power is also communicated to a memory block 252 which comprises 3 different types of memory including Static RAM, Flash ROM and EPROM. The memory 252 is utilized by the microprocessor 250 to perform read/write operations on the code and data stored in the 250 memory which signals pan and tilt commands to luminaire 10. A serial transceiver 254 provides RS 485 compatible signals to industry standard USITT DMX512 controllers and exchanges (receives and transmits) information with microprocessor 250. A slave serial module 256 receives information from microprocessor 250 and serializes data received and sends it out over 5 wires to slave modules including motor driver/sensor boards 94 which include infrared photo interrupter sensors 257, FIG. 3, which respond to tabs and/or notches on component parts of luminaire 10 such as notch 34a formed in gear 34, FIG. 2 or tab 86a on color filter 86, FIG. 3, which tells the microprocessor 250 the initial (zero or homing) position of motors 26, 82, respectively. The serial module 256 retrieves the position information from sensors 257 and sends it to the microprocessor 250 which determines whether to continue to move the filter or gear or to look for the tab/notch.

Another arrangement is illustrated in FIG. 10, and includes a fixture housing 510, a yoke 514 and an electronics housing 516. In this arrangement, power board 146 and logic board 246, FIGS. 8 and 9 are positioned in electronics housing 516. Also, in housing 516 are the previously described motor 26, bolt 28 and gear 24 arrangement, see FIG. 1, for driving the 360 degree pan position control which rotates housing 510 about centroidal axis P of shaft 522 which interconnects yoke 514 and electronics housing 516. No fan such as fan 48, described previously as being positioned in yoke 14, and cooperative vents 54, 56, are needed with removal of the electronics including logic board 246 and power board 146 from the yoke. The previously described tilt mechanism, see FIG. 1, including motor 31, belt 32 and gear 34, would however remain in the yoke to provide the 270 degree rotation. Housing 510 may also include contoured, radially directed cooling fins 562 formed as part of aluminum casting 557.

A stationary lens 96, is mounted in bezel 58, best shown in FIG. 1. Lens 96 is a common light diffusing lens similar to a lens used in an automotive headlight. Such lenses are commercially available. The above described combination of overlapping, rotating lenses 87, 88 and stationary lens 96 provide a beam angle which is preferably from about 10

degrees to about 60 degrees. This can be varied by rotation of lenses 87, 88 and enhanced by interchanging a selected diffusing lens 96.

While this invention has been illustrated and described in accordance with a preferred embodiment, it is recognized that variations and changes may be made therein without departing from the invention as set forth in the claims.

Having described the invention, what is claimed is:

1. A light fixture having multiple lens apparatus for changing a shape projected by a beam of light comprising:

means for projecting a generally circular beam of light, and overlapping lens devices each including a lenticular lens element movable into a position to interrupt the beam of light altering a circular beam pattern to a generally ellipsoidal beam pattern; and

motors to continuously move at least one of the lens devices relative to the beam of light.

2. The light fixture as defined in claim 1 wherein each of the lens devices are mounted in rotational mounts capable of relative adjacent rotation.

3. The light fixtures of claim 1 wherein the continuous movement is from one position to another.

4. A light fixture having multiple lens apparatus for changing a shape projected by a beam of light comprising:

means for projecting a generally circular beam of light, and overlapping lens devices each including a lenticular lens element movable into a position to interrupt the beam of light altering a circular beam pattern to a generally ellipsoidal beam pattern; and

motors to continuously move at least each lens devices relative to the beam of light.

5. The light fixtures of claim 4 wherein the continuous movement of one lens element is from one position to another and the continuous movement of the other lens element if from one position to another.

6. A light fixture having multiple lens apparatus for changing a shape projected by a beam of light comprising:

means for projecting a generally circular beam of light, and overlapping lens devices each including a lenticular lens element movable into a position to interrupt the beam of light altering a circular beam pattern to a generally ellipsoidal beam pattern; and

motors to continuously move at least each lens devices relative to the beam of light and relative to each other.

7. The light fixtures of claim 4 wherein the continuous movement of one lens element is from one position to another and the continuous movement of the other lens element is from one position to another.

* * * * *