



US005832151A

United States Patent [19]
Riser et al.

[11] **Patent Number:** **5,832,151**
[45] **Date of Patent:** **Nov. 3, 1998**

[54] **REFLECTOR AND ILLUMINATION SYSTEM**

[75] Inventors: **Andrew P. Riser**, Capistrano Beach, Calif.; **Richard E. Albrecht**, Chapel Hill, N.C.; **David H. Liu**, Rowland Heights; **Nguyen V. To**, Vista, both of Calif.

[73] Assignee: **Remote Source Lighting International, Inc**, San Juan Capistrano, Calif.

4,958,263	9/1990	Davenport et al.	362/32
4,961,622	10/1990	Gorman et al.	385/33 X
5,096,281	3/1992	Windebank et al.	359/868
5,222,793	6/1993	Davenport et al.	385/32
5,259,056	11/1993	Davenport et al.	385/115
5,367,590	11/1994	Davenport et al.	385/901 X
5,377,287	12/1994	Lee et al.	385/31
5,396,571	3/1995	Saadatmanesh et al.	385/33
5,502,514	3/1996	Vogeley et al.	348/771
5,559,911	9/1996	Forkner et al.	385/31 X
5,592,188	1/1997	Doherty et al.	345/84
5,682,448	10/1997	Riser et al.	385/31

[21] Appl. No.: **742,846**

[22] Filed: **Nov. 1, 1996**

Related U.S. Application Data

[63] Continuation-in-part of Ser. No. 374,163, Jan. 17, 1995, Pat. No. 5,559,911, Ser. No. 599,970, Feb. 14, 1996, and Ser. No. 645,327, May 13, 1996, Pat. No. 5,682,448.

[51] **Int. Cl.**⁶ **G02B 6/26**; G02B 5/10; F21V 7/04

[52] **U.S. Cl.** **385/31**; 385/901; 385/147; 385/39; 362/32; 362/341; 359/868

[58] **Field of Search** 385/31, 33, 34, 385/39, 47, 88, 92, 93, 94, 900, 901, 115, 119, 116, 147; 362/32, 61, 341; 359/868, 889, 838, 839

[56] **References Cited**

U.S. PATENT DOCUMENTS

4,050,784	9/1977	Kobayashi	385/34 X
4,389,698	6/1983	Cibie	362/32
4,704,660	11/1987	Robbins	362/32
4,811,171	3/1989	Viola	362/32
4,811,172	3/1989	Davenport et al.	362/61
4,816,975	3/1989	Bahnemann et al.	362/308
4,851,969	7/1989	Davenport et al.	362/61 X
4,868,718	9/1989	Davenport et al.	362/32
4,912,605	3/1990	Whitehead	362/32
4,949,227	8/1990	Finch et al.	362/61

FOREIGN PATENT DOCUMENTS

2651283	5/1978	Germany	362/32 X
63-291012	11/1988	Japan	385/33
6-174963	6/1994	Japan	385/24
2098311	11/1982	United Kingdom	385/901 X

Primary Examiner—Brian Healy

Attorney, Agent, or Firm—Donald E. Stout; Kenton R. Mullins

[57] **ABSTRACT**

An optical pipe illumination system is provided for coupling light from an illumination source to a number of output "light pipes", which are used for a variety of purposes, such as illuminating pools, spas, hazardous material zones, jail cells, and other applications where direct lighting is dangerous, difficult to maintain, or subject to vandalism. The illumination system employs an illumination reflector which has been customized to maximize the efficiency of light transmission between the illumination source, such as an arc lamp, and the cores of the output pipes. A method of fabricating the customized illumination reflector includes mapping the radiation patterns of the particular illumination source to be utilized, creating a database of those radiation patterns, and utilizing the database to generate an optimal illumination reflector configuration. The computer-generated reflector will virtually always be a non-conic section, because the illumination source is not ideal.

20 Claims, 8 Drawing Sheets

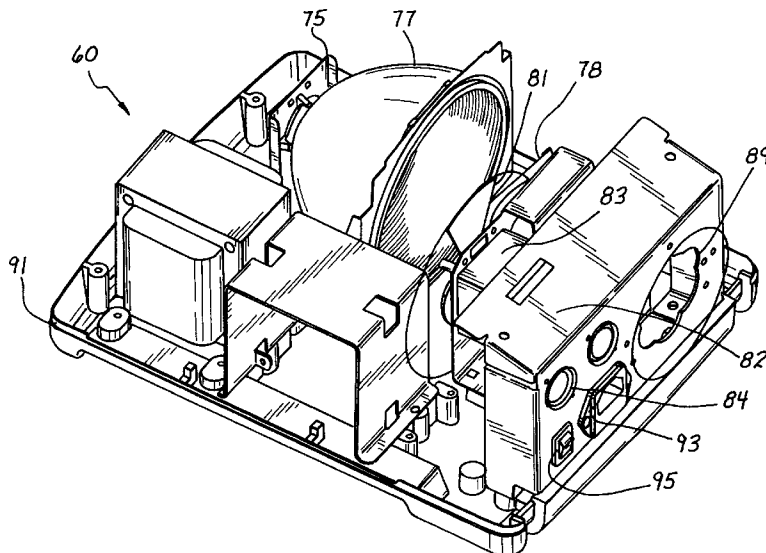

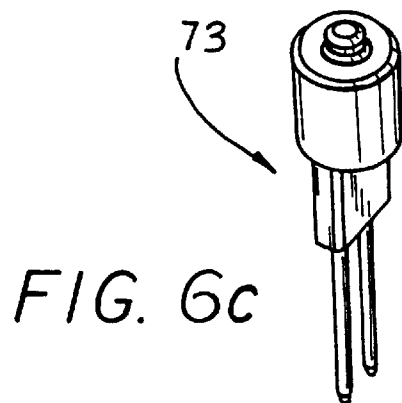
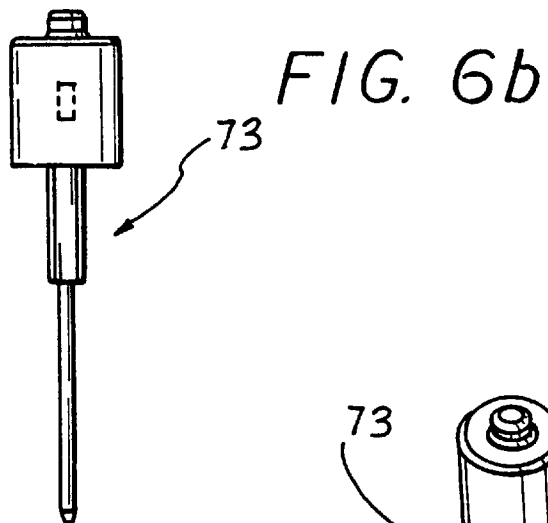
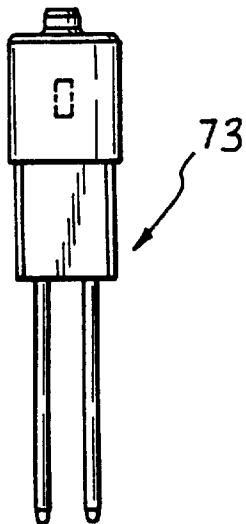
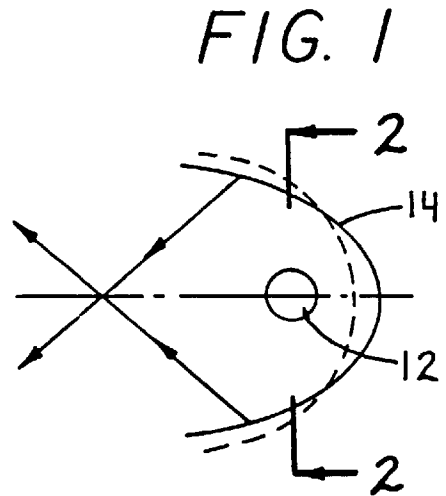
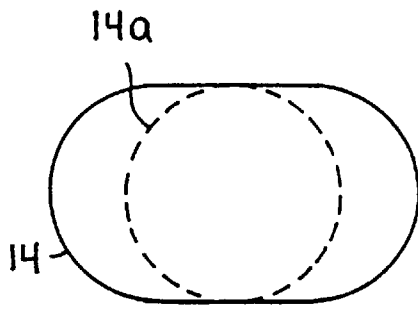

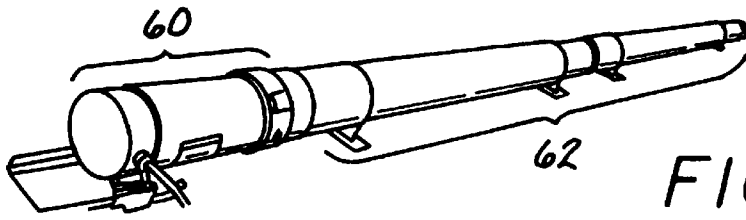

FIG. 3

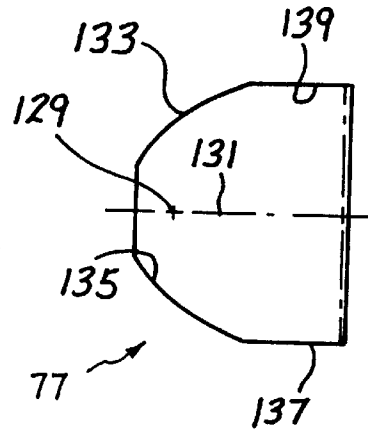

FIG. 7

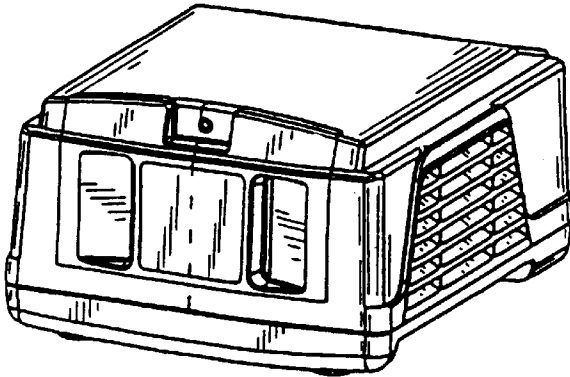
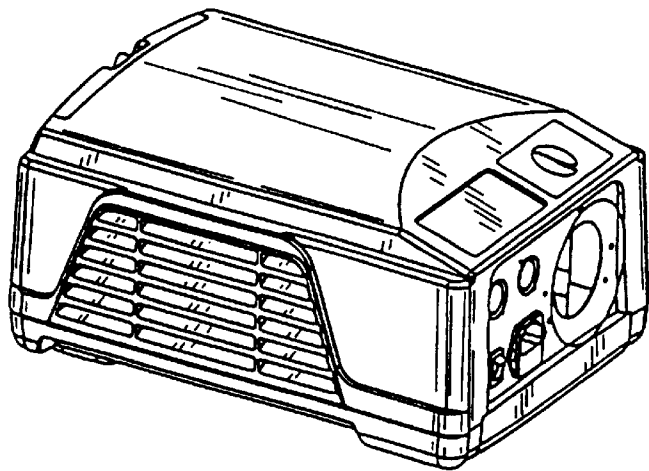

FIG. 10a

FIG. 10b



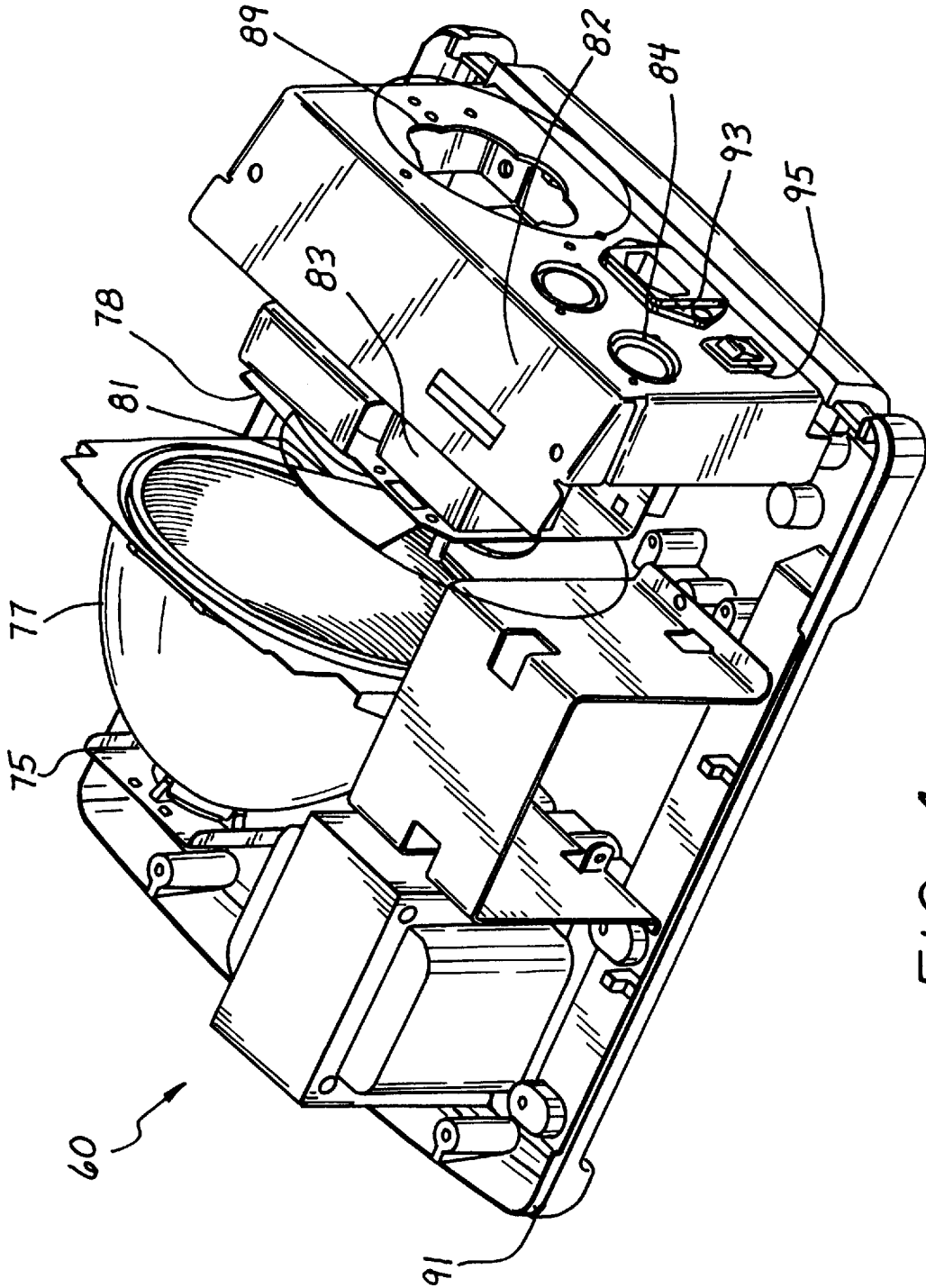

FIG. 4

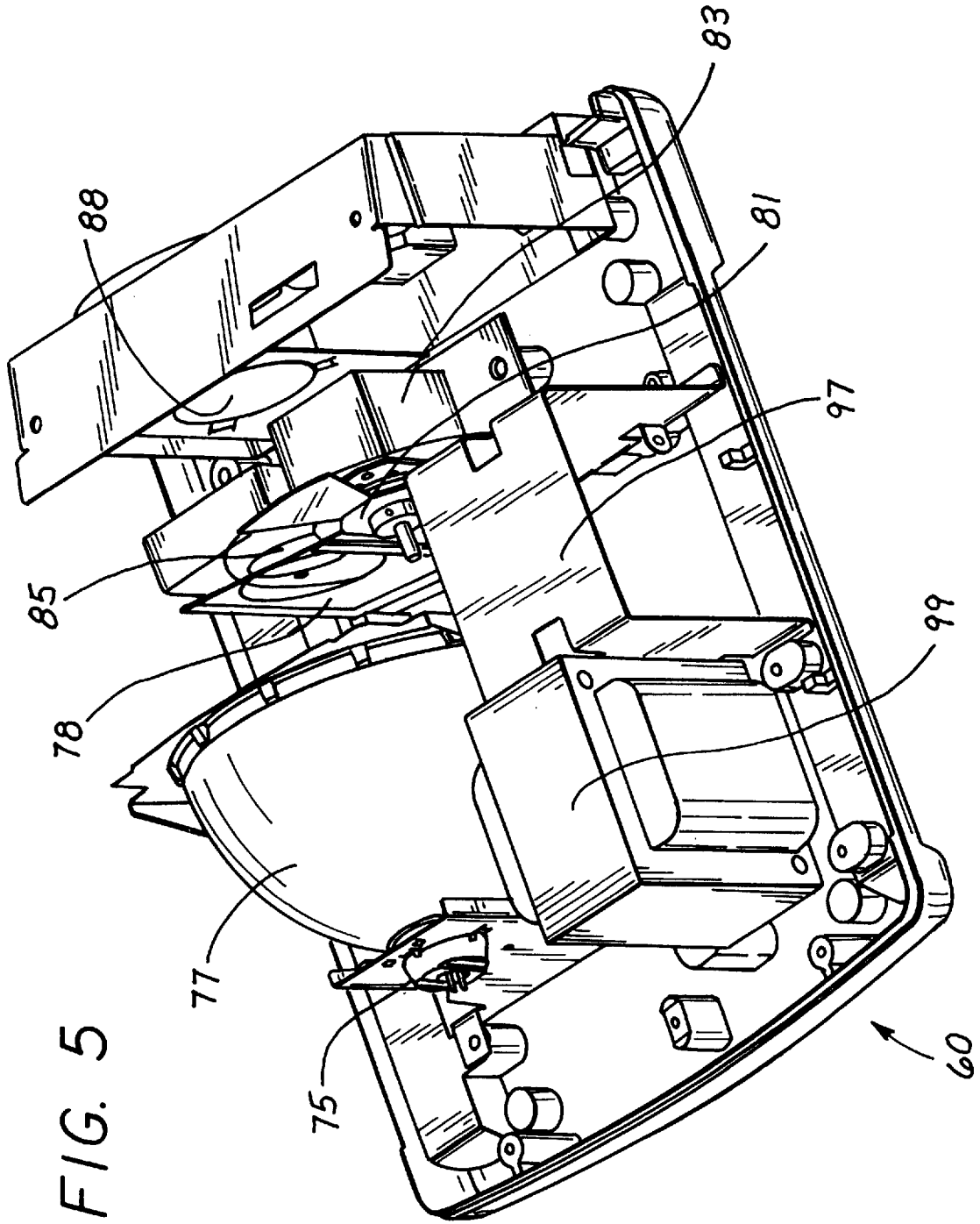

FIG. 5

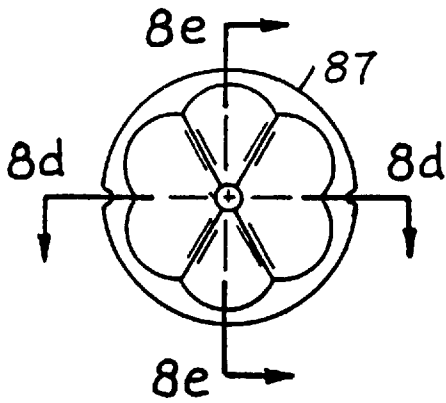

FIG. 8a

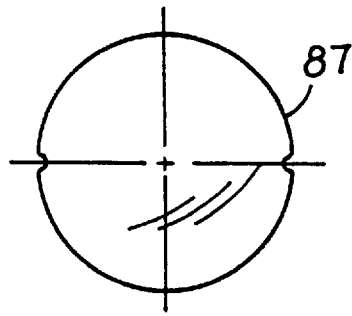

FIG. 8b

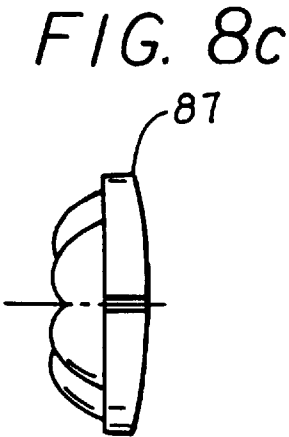

FIG. 8c

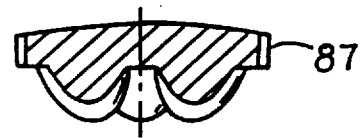

FIG. 8d

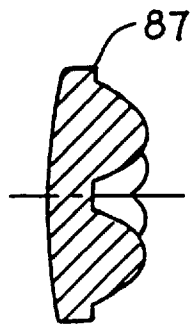

FIG. 8e

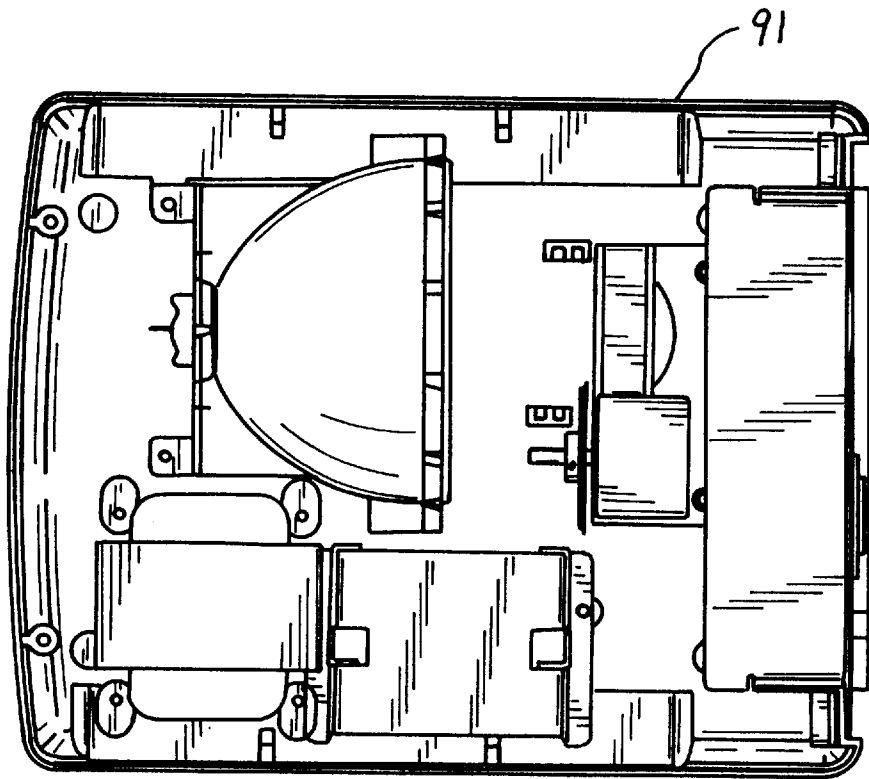
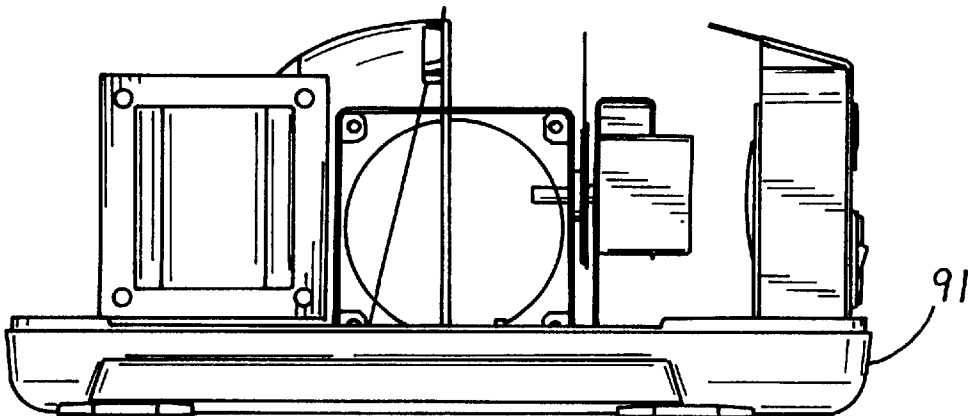

FIG. 9a

FIG. 9b



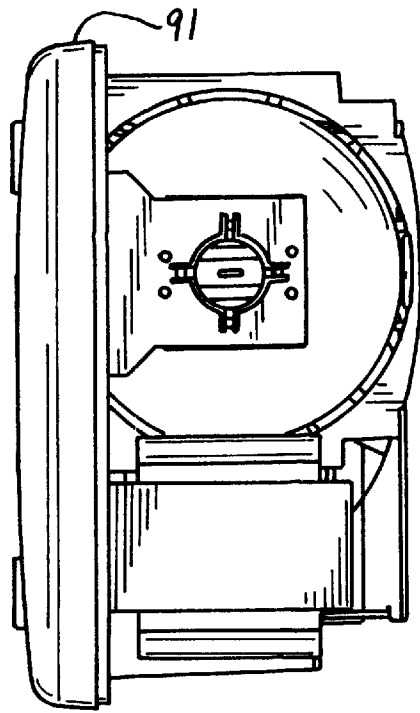

FIG. 9c

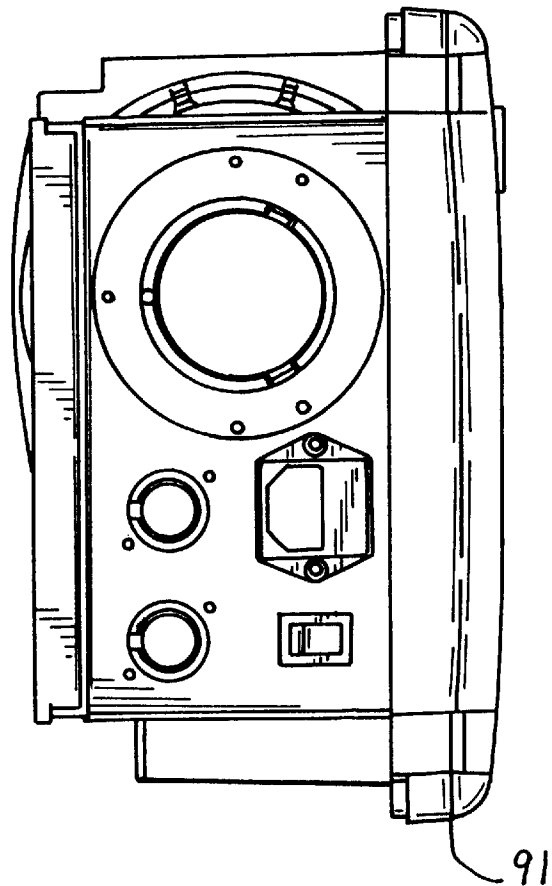

FIG. 9d

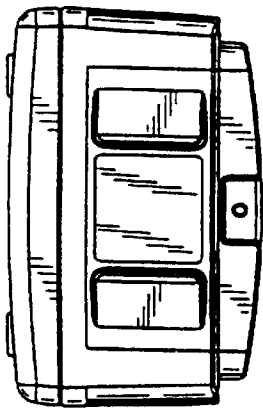

FIG. 10c

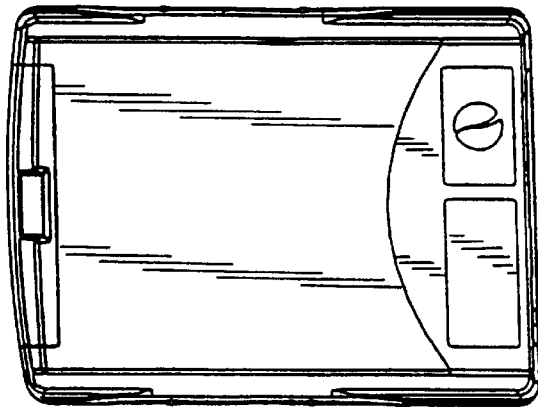

FIG. 10d

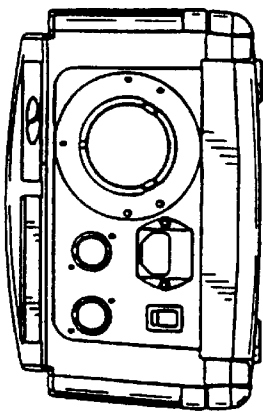

FIG. 10e

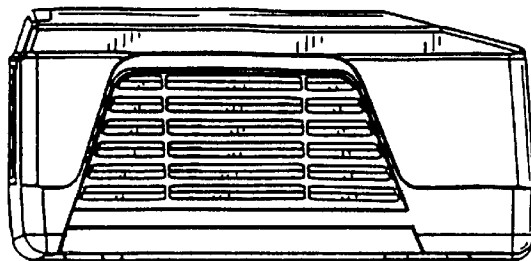

FIG. 10f

REFLECTOR AND ILLUMINATION SYSTEM

This application is a continuation-in-part of U.S. Ser. No. 08/374,163, entitled OPTICAL COUPLER and filed on Jan. 17, 1995, which issued into U.S. Pat. No. 5,559,911; U.S. Ser. No. 08/599,970, entitled OPTICAL COUPLER and filed on Feb. 14, 1996; pending and U.S. Ser. No. 08/645,327, entitled REFLECTOR AND ILLUMINATOR SYSTEM and filed on May 13, 1996, now U.S. Pat. No. 5,682,448 all three of which are expressly incorporated herein by reference.

BACKGROUND OF THE INVENTION

Large diameter fiber optics, often referred to as “flexible light pipes”, are well known in the art, and typically comprise a single, solid core fiber which is surrounded by a cladding layer and a sheath or shielding layer. The core is the portion of a light pipe which transmits light, and typically has a diameter of about 2 to 12 mm. It is formed of a very soft, semi-liquid plastic material, such as OPTIFLEX®, which is manufactured by Rohm & Haas Corporation, of Philadelphia, Pa. The cladding layer typically comprises polytetrafluoroethylene (PTFE or TEFLON®), or the like, while the outer sheath is fabricated of a material such as polyvinylchloride (PVC). Unlike small diameter optical fibers, which are typically used to transmit information in relatively complex control systems, these large diameter “light pipes” are typically employed in a variety of illumination systems where direct lighting is difficult to maintain, dangerous, or subject to vandalism. Examples include architectural lighting, display cases, pools and spas (to eliminate electrical connections near water), hazardous material zones (to eliminate the need for sealed lighting), or jail cells. They are particularly advantageous in that only a single centralized illumination system must be maintained, rather than a plurality of individual lights.

One disadvantage of these prior art systems, however, is their use of an illumination reflector to transmit light between the source of illumination and the output optical fiber or pipe. These conventional illumination reflectors are based upon classic conic sections; i.e. elliptical or parabolic reflectors. Such reflectors are best for “ideal” light sources; i.e. “point” sources, but for “real world” light sources, light transmission efficiency is reduced.

SUMMARY OF THE INVENTION

This invention is an improvement over the prior art described above, because it employs an illumination reflector which has been customized to maximize the efficiency of light transmission between the illumination source, such as an arc lamp, and the core of one or more output fibers or pipes. A method of fabricating the customized illumination reflector includes mapping the radiation patterns of the particular illumination source to be utilized, creating a database of those radiation patterns, and utilizing the database to generate an optimal illumination reflector configuration. The computer-generated reflector will virtually always be a non-conic section, because the illumination source is not ideal.

More particularly, an optical fiber illumination system for coupling light from an illumination source to a number of output optical pipes is disclosed. Each output optical pipe has a proximal end for receiving the light, and the illumination system includes an illumination reflector for receiving illumination from the illumination source and redirecting the illumination to the proximal end of each output optical

pipe. The illumination reflector is particularly designed to complement the illumination source with which it is paired, and therefore has a computer-generated non-circular cross-section and is both non-elliptical and non-parabolic.

In another aspect of the invention, a method of fabricating an illumination reflector for an illumination system is disclosed. Steps in the method include mapping the radiation patterns of the illumination source, and creating a database of these radiation patterns. Then, the database is used to generate an illumination reflector configuration which provides an optimal distribution and intensity of illumination at a proximal end of each output optical pipe.

The illumination system of the present invention preferably uses either a 175 watt halogen bulb or a 200 watt halogen bulb. Additionally, a homogenizer lens assembly is used in place of a mixing rod. Also, light from the illumination reflector is passed through a color wheel, before being directed into the output optical pipe or pipes. The color wheel is a DMX addressable color changer for control of multiple colors from a one-touch source.

The present invention, together with additional features and advantages thereof, may best be understood by reference to the following description taken in connection with the accompanying illustrative drawings.

BRIEF DESCRIPTION OF THE FIGURES

FIG. 1 is a schematic top view of the present invention, illustrating an illumination source and an illumination reflector having a computer-generated curvature;

FIG. 2 is a cross-sectional view taken along lines 2—2 of FIG. 1, particularly illustrating the illumination reflector fabricated in accordance with the principles of the present invention;

FIG. 3 is a perspective view of the illumination system of the present invention;

FIGS. 4 and 5 are various views of the light source portion of the illumination system of the present invention;

FIGS. 6a—6c are various views of the light source of the presently preferred embodiment;

FIG. 7 is a schematic view of the computer-generated illumination reflector of the presently preferred embodiment;

FIGS. 8a—8e are various views of the segmented lens of the presently preferred embodiment;

FIGS. 9a—9d are various views of the light source portion, with the cover removed, of the illumination system of the present invention; and

FIGS. 10a—10f are various views of the light source portion of the illumination system of the present invention.

DETAILED DESCRIPTION OF THE PREFERRED EMBODIMENT

Referring now more specifically to the drawings, FIGS. 1 and 2 illustrate a source of illumination 12, comprising any conventional light source, such as an arc lamp or the like, and an illumination reflector 14, which reflects the light from the lamp to another optical component (not shown).

Turning to FIG. 3, a perspective view of the illumination system of the present invention is illustrated. The illumination system comprises a light source portion 60 and a delivery portion 62. The light source 60 may comprise a cylindrical housing, as shown in FIG. 3, or may comprise a rectangular housing, such as shown in FIGS. 10a—10f, for example. The illumination system may be used for a variety

of purposes, such as illuminating pools, spas, hazardous material zones, jail cells, and other applications where direct lighting is dangerous, difficult to maintain, or subject to vandalism.

FIGS. 4 and 5 illustrate perspective views of the light source portion 60 of the illumination system of the presently preferred embodiment. FIG. 4 illustrates a right-side perspective view of the light source portion 60 of the present invention, and FIG. 5 illustrates a left-side perspective view of the light source portion 60 of the present invention. A bulb 73 (FIGS. 6a-6c) fits within a socket mount 75 and comprises an illuminating portion, which is surrounded by the illumination reflector 77 of the present invention.

The illumination reflector 77 of the present invention directs light from the bulb 73 through the bracket/filter mirror assembly 78 and into the color wheel 81. The color wheel 81 preferably comprises a DMX addressable color changer for control of multiple colors from one source. This color changer is preferably controlled by a touch panel, and comprises a single wheel with eight dichroic color filters. According to one alternative embodiment, the color changer further comprises a DMX dimming capability. A motor 83 drives the color wheel 81, and the light from the bulb 73 enters the homogenizer lens assembly 85 (FIG. 5) after passing through the color wheel 81. The light next passes through a segmented lens 87 (FIGS. 8a-8e), before being directed into a plurality of optical fibers or light pipes (not shown). As presently embodied, a convex lens 88 is disposed between the homogenizer lens assembly 85 and the segmented lens 87.

FIGS. 8a-8e illustrate various views of the segmented lens 87. As presently preferred, the segmented lens 87 comprises six segments. Each segment of the segmented lens 87 is adapted for passing light into a corresponding optical fiber or light pipe. FIG. 8a is a front elevational view of the segmented lens 87; FIG. 8b is a rear-view of the segmented lens 87; and FIG. 8c is a side-elevational view of the segmented lens 87. FIGS. 8d and 8e are cross-sectional views of the segmented lens 87. The segmented lens 87 is adapted for being secured to the output end 89 (FIG. 4) of the housing 91. Alternatively, different numbers of segments may be configured, or only a single lens may be used instead of the segmented lens 87.

A nut (not shown) is preferably used to secure optical fibers or light pipes to the housing 91 of the light source portion 60. The nut is secured to the output end 89 of the housing 91 and, when secured thereto, sandwiches a flange portion of the segmented lens 87 to the output end 89 of the housing 91. The distal end of the light source portion 60, located opposite the optical fibers, comprises a power outlet 93 and an on/off switch 95, as illustrated in FIG. 4. The front panel 82 of the housing 91 further comprises a DMX connector 84. FIG. 5 shows that a side of the housing comprises a fan assembly 97 and a transformer 99. FIGS. 9a-9d illustrate various views of the housing 91, with the top cover removed. FIGS. 9a-9d generally correspond to FIGS. 4 and 5.

FIG. 7 illustrates a cross-sectional view of the illumination reflector 77 of the presently preferred embodiment, which differs from conventional illumination reflectors by having a computer-generated curvature, which maximizes reflections of light from the bulb 73 into the color wheel 81. The illumination reflector 77 comprises a focal point 129, which is arbitrarily defined along the axis 131. The illumination reflector 77 comprises two curved surfaces 133 and 135, which preferably terminate at a two degree draft angle

defining the straight surfaces 137 and 139, respectively. The straight surfaces 137 and 139 facilitate manufacturing and assembly convenience, but are not required. The illumination reflector 77 is preferably manufactured using a technique of nickel deposition or spinning. The illumination reflector 77 is then coated with aluminum for enhanced reflectivity.

An important aspect of the invention, which substantially improves the efficiency of the inventive system, is the use of non-classical, non-conic sections in the design of the illumination reflector 14. In the prior art, in contrast, classical conic sections are typically used in illumination reflector design, to create elliptical or parabolic reflectors. By way of background, classical conic sections are so-named because they can be generated (and perhaps more importantly, visualized) by imagining the plane that would be exposed by slicing through a circular section cone. For example, if such a cone is sliced through with a cut that is exactly perpendicular to the long axis of the cone, the resulting exposed plane is a circle. This is the simplest example of a conic section. Like the other conic sections, the circle can be described algebraically, in this case by the expression:

$$(x^2 + y^2)^{1/2} = r \quad (1)$$

wherein r is the radius of the circle, x is the x -coordinate value of the radius, and y is the y -coordinate value of the radius. In other words, the radius magnitude of the circle is always equal to the square root of the sum of the squares of its x - y coordinate values. The properties which this confers on the circle are that it has a single focal point equidistant from the focus of its circumference points, and that focus is in the center. This characteristic can be quite useful in optics.

If the slicing plane of the theoretical cone were to be tilted away from the perpendicular to the axis, other classical conic shapes are generated, not much more complex in mathematical description than the circle, but with ever more intriguing properties. From the standpoint of the history of optical design, two of the most important are the ellipse and the parabola.

The ellipse is a closed oval, and can be imagined by looking at the shape the edge of a circular coin makes as it is progressively tilted with respect to the observer's line of sight. The ellipse has the properties of having two focal points, or foci, both located along the line bisecting the ellipse's long axis (the circle is actually a special case of the ellipse, where the two foci are superimposed on one another, occupying the same point in space). The optical properties of an ellipse are such that any rays of light originating from exactly the point of focus on one side of the ellipse will be brought exactly to convergence at the complementary focus location, irrespective of their direction of origin.

Unlike the ellipse, the parabola comprises an open-figure shape. It is generated by slicing the cone along a line parallel to its long axis, all the way down to its base. The resulting shape has a vertex at the small end and an open mouth opposite. The parabola has but a single focus. Its optical properties are such that a ray of light leaving the exact point of focus and bouncing off the surface of a parabolic reflector will exit the open mouth going exactly parallel to the long axis of the parabola, no matter where the ray strikes the reflector. Flashlight reflectors are often parabolic; by collimating the light (i.e. making all the rays travel parallel paths), the flashlight beam can be directed where it is needed and deliver the most light to the area of interest, instead of illuminating a large area dimly, as a non-directed bulb would do.

As a collector of light, the parabola has the ability to take collimated light directed toward it and concentrate that light

at the focus point. This makes parabolic shapes useful for solar energy collectors.

The inventors have discovered, however, that the problem with using classical elliptical and parabolic reflectors, as contemplated in the prior art, is that, while the above analysis is done based upon ideal assumptions; i.e. that the light source occupies a "point" in space in the purest mathematical sense, in that it is dimensionless. If a light source used to illuminate an elliptical or parabolic reflector could occupy a dimensional space of zero, the easily-described, well-behaved "ideal" properties of these shapes would be realized. However such a light source is impossible in the physical world; a light source of zero dimension would, by definition, be infinitely bright. In the physical world, a light source is a very real, three dimensional object, whether it is the tungsten filament of an incandescent lamp, the arc of an arc lamp, or the glowing surface of a fluorescent lamp. Compared to the theoretically ideal "point source", all of these emitters of light are not only large, but generally of complex, and sometimes bizarre, shape.

What this means is that an "ideal" conic or parabolic reflector using a "real" light source not only does not conform to its theoretically predicted performance, but often diverges wildly from the expected behavior. In the prior art, this discrepancy between the theoretical and the realized behavior of conic-shape-based reflectors is just a tough fact of life. No good analytical tools have existed to help understand it, and no design tools existed to help overcome it.

The inventive new non-traditional approach utilizes non-conic sections. The designer is freed from the artifice of employing classical, easily-described shapes whose real-world performance may be fatally compromised, and given the freedom to use non-classical shapes, difficult to describe mathematically but amenable to analysis by the considerable number-crunching power of modern personal computers.

Thus, the inventive method for fabricating the reflector **14** shown in FIGS. **1** and **2** begins with the mapping of the complex radiation patterns of the real lamp **12** to be utilized in the particular apparatus. In a customized application, the lamp actually used in each individual device might actually be individually mapped. However, more typically, a particular manufacturer's lamp, designed by model number, is mapped, and the vagaries between individual lamps of a particular model or type of lamp, typically quite small, are ignored for the sake of manufacturing practicality and reasonable cost.

In the presently preferred embodiment, either a 175 watt halogen bulb or a 200 watt halogen bulb **73** is used. Other bulbs may be used, as long as the model or product number of the specific bulb is noted for easy future reference.

Mapping in this sense, means to generate a collection of spatial intensity distribution measurements at a constant radial distance from the lamp, and storing the data in a computer storage location. This is done by moving a calibrated imaging detector array around the source in spherical coordinates until a detailed data file is obtained, point-by-point, of the lamp's specific radiation patterns. This detailed file does not really care about the relative "idealness" of the source; rather, the file contains a description of the radiation patterns emitted by the source, which are, by definition, what the reflector surface will actually "see."

Once the mapping process is complete, computer software is used to play the file containing the lamp's complex three-space emission pattern against the surface of any arbitrarily-defined reflector surface, whether a classic conic section or not, whether round (a surface of rotation) or not,

whether comprised of smooth curves or an array of discrete facts. A focal point is defined on the surface, and the lamp is simulated to be placed at the focal point. The results of playing the lamp's real radiation patterns against the real reflector surface yields a highly accurate prediction of exactly what the resulting radiation product will look like at any point in space. The prediction can include the light intensity at any point, the rate of change of intensity between arbitrary points in the field, the angles of incidence of light through a given point, and other relevant measurements. This analytical power affords the ability to tailor the lamp/reflector combination to best satisfy the illumination requirements of the particular application, both in spatial intensity and angular distribution.

According to one specific implementation of the presently preferred embodiment, the above-mentioned 175 or 200 watt halogen bulb is used in connection with the above-described method to generate an illumination reflector **77** having an optimized curvature. The dimensions of the curvature are expressed below in z and y coordinates, where the y coordinates are measured along an axis **131** (FIG. **5**) that extends perpendicularly to the base of the illumination reflector **77** and through the bulb **73** (FIG. **4**). The z coordinates are expressed in radial distances from the y axis. The specific coordinates for the illumination reflector **77** are reproduced below:

-9.233051e-001	3.000000e-001
-9.223477e-001	3.050373e-001
-9.213737e-001	3.100762e-001
-9.203830e-001	3.151173e-001
-9.193758e-001	3.201601e-001
-9.183519e-001	3.252051e-001
-9.173112e-001	3.302519e-001
-9.162537e-001	3.353006e-001
-9.151795e-001	3.403517e-001
-9.140885e-001	3.454044e-001
-9.129804e-001	3.504596e-001
-9.118558e-001	3.555168e-001
-9.107137e-001	3.605759e-001
-9.095548e-001	3.656376e-001
-9.083787e-001	3.707013e-001
-9.071855e-001	3.757674e-001
-9.059753e-001	3.808354e-001
-9.047478e-001	3.859062e-001
-9.035031e-001	3.909791e-001
-9.022409e-001	3.960544e-001
-9.009613e-001	4.011321e-001
-8.996643e-001	4.062121e-001
-8.983498e-001	4.112947e-001
-8.970177e-001	4.163798e-001
-8.956681e-001	4.214673e-001
-8.943009e-001	4.265575e-001
-8.929159e-001	4.316501e-001
-8.915132e-001	4.367454e-001
-8.900926e-001	4.418433e-001
-8.886542e-001	4.469439e-001
-8.871978e-001	4.520473e-001
-8.857234e-001	4.571531e-001
-8.842309e-001	4.622618e-001
-8.827202e-001	4.673732e-001
-8.811914e-001	4.724876e-001
-8.796443e-001	4.776047e-001
-8.780789e-001	4.827247e-001
-8.764951e-001	4.878476e-001
-8.748929e-001	4.929732e-001
-8.732721e-001	4.981020e-001
-8.716325e-001	5.032336e-001
-8.699744e-001	5.083683e-001
-8.682976e-001	5.135059e-001
-8.666021e-001	5.186465e-001
-8.648875e-001	5.237904e-001
-8.631541e-001	5.289372e-001
-8.614016e-001	5.340872e-001

-continued

-8.596301e-001	5.392405e-001
-8.578394e-001	5.443968e-001
-8.560294e-001	5.495564e-001
-8.542002e-001	5.547192e-001
-8.523515e-001	5.598854e-001
-8.504834e-001	5.650548e-001
-8.485957e-001	5.702275e-001
-8.466883e-001	5.754034e-001
-8.447612e-001	5.805828e-001
-8.428143e-001	5.857655e-001
-8.408476e-001	5.909519e-001
-8.388608e-001	5.961415e-001
-8.368539e-001	6.013345e-001
-8.348268e-001	6.065311e-001
-8.327798e-001	6.117314e-001
-8.307123e-001	6.169351e-001
-8.286244e-001	6.221422e-001
-8.265160e-001	6.273532e-001
-8.243871e-001	6.325676e-001
-8.222374e-001	6.377859e-001
-8.200670e-001	6.430076e-001
-8.178757e-001	6.482331e-001
-8.156635e-001	6.534624e-001
-8.134302e-001	6.586952e-001
-8.111757e-001	6.639320e-001
-8.089000e-001	6.691725e-001
-8.066029e-001	6.744168e-001
-8.042844e-001	6.796650e-001
-8.019444e-001	6.849169e-001
-7.995827e-001	6.901728e-001
-7.971994e-001	6.954326e-001
-7.947941e-001	7.006965e-001
-7.923669e-001	7.059641e-001
-7.899176e-001	7.112359e-001
-7.874461e-001	7.165115e-001
-7.849525e-001	7.217912e-001
-7.824362e-001	7.270749e-001
-7.798976e-001	7.323627e-001
-7.773362e-001	7.376544e-001
-7.747521e-001	7.429504e-001
-7.721453e-001	7.482504e-001
-7.695155e-001	7.535546e-001
-7.668629e-001	7.588632e-001
-7.641869e-001	7.641759e-001
-7.614874e-001	7.694926e-001
-7.587646e-001	7.748135e-001
-7.560183e-001	7.801387e-001
-7.537116e-001	7.854798e-001
-7.513885e-001	7.890238e-001
-7.490488e-001	7.934707e-001
-7.466925e-001	7.979207e-001
-7.443193e-001	8.023735e-001
-7.419294e-001	8.068295e-001
-7.395225e-001	8.112884e-001
-7.370989e-001	8.157505e-001
-7.346582e-001	8.202154e-001
-7.322002e-001	8.246835e-001
-7.297251e-001	8.291546e-001
-7.272329e-001	8.336289e-001
-7.247231e-001	8.381059e-001
-7.221960e-001	8.425863e-001
-7.196514e-001	8.470696e-001
-7.170892e-001	8.515562e-001
-7.145095e-001	8.560460e-001
-7.119121e-001	8.605387e-001
-7.092968e-001	8.650347e-001
-7.066635e-001	8.695338e-001
-7.040124e-001	8.740359e-001
-7.013431e-001	8.785412e-001
-6.986557e-001	8.830498e-001
-6.959500e-001	8.875615e-001
-6.932261e-001	8.920763e-001
-6.904837e-001	8.965944e-001
-6.877229e-001	9.011157e-001
-6.849435e-001	9.056401e-001
-6.821454e-001	9.101678e-001
-6.793285e-001	9.146987e-001
-6.764928e-001	9.192327e-001
-6.736381e-001	9.237698e-001
-6.707643e-001	9.283103e-001

-continued

-6.678716e-001	9.328540e-001
-6.649595e-001	9.374009e-001
-6.620281e-001	9.419510e-001
-6.590773e-001	9.465044e-001
-6.561070e-001	9.510610e-001
-6.531172e-001	9.556208e-001
-6.501076e-001	9.601840e-001
-6.470782e-001	9.647504e-001
-6.440291e-001	9.693201e-001
-6.409597e-001	9.738930e-001
-6.378705e-001	9.784693e-001
-6.347611e-001	9.830488e-001
-6.316313e-001	9.876316e-001
-6.284812e-001	9.922174e-001
-6.253105e-001	9.968067e-001
-6.221192e-001	1.001399e+000
-6.189073e-001	1.005995e+000
-6.156746e-001	1.010594e+000
-6.124209e-001	1.015197e+000
-6.091463e-001	1.019802e+000
-6.058850e-001	1.024411e+000
-6.025335e-001	1.029024e+000
-5.991952e-001	1.033639e+000
-5.958354e-001	1.038258e+000
-5.924541e-001	1.042880e+000
-5.890511e-001	1.047506e+000
-5.856262e-001	1.052134e+000
-5.821796e-001	1.056766e+000
-5.787108e-001	1.061401e+000
-5.752199e-001	1.066040e+000
-5.717068e-001	1.070681e+000
-5.681713e-001	1.075327e+000
-5.646135e-001	1.079975e+000
-5.610331e-001	1.084626e+000
-5.574298e-001	1.089281e+000
-5.538036e-001	1.093939e+000
-5.501546e-001	1.098600e+000
-5.464825e-001	1.103265e+000
-5.427871e-001	1.107932e+000
-5.390684e-001	1.112603e+000
-5.353261e-001	1.117278e+000
-5.315600e-001	1.121955e+000
-5.277704e-001	1.126636e+000
-5.239570e-001	1.131320e+000
-5.201197e-001	1.136007e+000
-5.162581e-001	1.140698e+000
-5.123724e-001	1.145391e+000
-5.084624e-001	1.150088e+000
-5.045278e-001	1.154788e+000
-5.005687e-001	1.159491e+000
-4.965849e-001	1.164197e+000
-4.925762e-001	1.168907e+000
-4.885423e-001	1.173619e+000
-4.844834e-001	1.178334e+000
-4.803991e-001	1.183053e+000
-4.771134e-001	1.186830e+000
-4.738113e-001	1.190609e+000
-4.704929e-001	1.194390e+000
-4.671579e-001	1.198172e+000
-4.638065e-001	1.201957e+000
-4.604383e-001	1.205744e+000
-4.570535e-001	1.209532e+000
-4.536518e-001	1.213323e+000
-4.502332e-001	1.217115e+000
-4.467977e-001	1.220909e+000
-4.433452e-001	1.224706e+000
-4.398757e-001	1.228504e+000
-4.363889e-001	1.232304e+000
-4.328850e-001	1.236105e+000
-4.293637e-001	1.239909e+000
-4.258251e-001	1.243714e+000
-4.222689e-001	1.247521e+000
-4.186952e-001	1.251330e+000
-4.151039e-001	1.255141e+000
-4.114947e-001	1.258954e+000
-4.078680e-001	1.262768e+000
-4.042232e-001	1.266584e+000
-4.005606e-001	1.270402e+000
-3.968799e-001	1.274221e+000
-3.931811e-001	1.278042e+000

-continued

-3.894641e-001 1.281865e+000
 -3.857289e-001 1.285690e+000
 -3.819752e-001 1.289516e+000
 -3.782030e-001 1.293344e+000
 -3.744125e-001 1.297174e+000
 -3.706032e-001 1.301005e+000
 -3.667753e-001 1.304838e+000
 -3.629286e-001 1.308673e+000
 -3.590630e-001 1.312509e+000
 -3.551784e-001 1.316347e+000
 -3.512750e-001 1.320186e+000
 -3.473522e-001 1.324027e+000
 -3.434103e-001 1.327869e+000
 -3.394491e-001 1.331713e+000
 -3.354684e-001 1.335558e+000
 -3.314684e-001 1.339405e+000
 -3.274487e-001 1.343253e+000
 -3.234094e-001 1.347103e+000
 -3.193502e-001 1.350954e+000
 -3.152713e-001 1.354807e+000
 -3.111724e-001 1.358661e+000
 -3.070536e-001 1.362516e+000
 -3.029145e-001 1.366373e+000
 -2.987552e-001 1.370231e+000
 -2.945757e-001 1.374090e+000
 -2.903756e-001 1.377950e+000
 -2.861553e-001 1.381812e+000
 -2.819141e-001 1.385675e+000
 -2.776525e-001 1.389539e+000
 -2.733699e-001 1.393405e+000
 -2.690665e-001 1.397271e+000
 -2.647421e-001 1.401139e+000
 -2.603965e-001 1.405008e+000
 -2.560300e-001 1.408877e+000
 -2.516420e-001 1.412749e+000
 -2.472328e-001 1.416620e+000
 -2.428019e-001 1.420493e+000
 -2.383497e-001 1.424368e+000
 -2.338756e-001 1.428243e+000
 -2.293799e-001 1.432119e+000
 -2.248621e-001 1.435996e+000
 -2.203224e-001 1.439873e+000
 -2.157608e-001 1.443752e+000
 -2.111768e-001 1.447631e+000
 -2.065707e-001 1.451512e+000
 -2.019420e-001 1.455393e+000
 -1.972910e-001 1.459275e+000
 -1.926172e-001 1.463157e+000
 -1.879208e-001 1.467040e+000
 -1.832015e-001 1.470924e+000
 -1.784592e-001 1.474808e+000
 -1.736941e-001 1.478693e+000
 -1.689056e-001 1.482579e+000
 -1.640942e-001 1.486465e+000
 -1.592591e-001 1.490351e+000
 -1.544008e-001 1.494238e+000
 -1.495187e-001 1.498126e+000
 -1.446131e-001 1.502014e+000
 -1.396835e-001 1.505902e+000
 -1.347299e-001 1.509791e+000
 -1.297525e-001 1.513679e+000
 -1.247508e-001 1.517568e+000
 -1.197250e-001 1.521457e+000
 -1.146747e-001 1.525347e+000
 -1.096000e-001 1.529236e+000
 -1.045006e-001 1.533126e+000
 -9.937663e-002 1.537015e+000
 -9.422766e-002 1.540905e+000
 -8.905388e-002 1.544794e+000
 -8.385488e-002 1.548684e+000
 -7.863066e-002 1.552573e+000
 -7.338132e-002 1.556462e+000
 -6.810638e-002 1.560351e+000
 -6.280605e-002 1.564240e+000
 -5.747988e-002 1.568128e+000
 -5.212810e-002 1.572016e+000
 -4.675021e-002 1.575903e+000
 -4.134648e-002 1.579790e+000
 -3.727638e-002 1.582705e+000
 -3.319151e-002 1.585620e+000

-continued

-2.909201e-002 1.588534e+000
 -2.497745e-002 1.591448e+000
 -2.084796e-002 1.594362e+000
 -1.670369e-002 1.597275e+000
 -1.254420e-002 1.600188e+000
 -8.369619e-003 1.603101e+000
 -4.180094e-003 1.606013e+000
 2.481236e-005 1.608924e+000
 4.244964e-003 1.611835e+000
 8.480221e-003 1.614746e+000
 1.273102e-002 1.617656e+000
 1.699724e-002 1.620565e+000
 2.127871e-002 1.623474e+000
 2.557590e-002 1.626382e+000
 2.988866e-002 1.629290e+000
 3.421685e-002 1.632197e+000
 3.856092e-002 1.635103e+000
 4.292073e-002 1.638008e+000
 4.729613e-002 1.640913e+000
 5.168757e-002 1.643817e+000
 5.609492e-002 1.646721e+000
 6.051803e-002 1.649623e+000
 6.495736e-002 1.652524e+000
 6.941275e-002 1.655425e+000
 7.388408e-002 1.658325e+000
 7.837179e-002 1.661224e+000
 8.287575e-002 1.664122e+000
 8.739579e-002 1.667018e+000
 9.193241e-002 1.669914e+000
 9.648544e-002 1.672809e+000
 1.010547e-001 1.675703e+000
 1.056408e-001 1.678596e+000
 1.102434e-001 1.681488e+000
 1.148625e-001 1.684378e+000
 1.194984e-001 1.687268e+000
 1.241512e-001 1.690156e+000
 1.288205e-001 1.693043e+000
 1.335070e-001 1.695929e+000
 1.382104e-001 1.698813e+000
 1.429305e-001 1.701696e+000
 1.476680e-001 1.704578e+000
 1.524225e-001 1.707458e+000
 1.571941e-001 1.710337e+000
 1.619831e-001 1.713215e+000
 1.667894e-001 1.716091e+000
 1.716128e-001 1.718965e+000
 1.764539e-001 1.721838e+000
 1.813124e-001 1.724710e+000
 1.861883e-001 1.727579e+000
 1.910820e-001 1.730448e+000
 1.959933e-001 1.733314e+000
 2.009222e-001 1.736179e+000
 2.058690e-001 1.739042e+000
 2.108338e-001 1.741903e+000
 2.158162e-001 1.744762e+000
 2.208168e-001 1.747620e+000
 2.258354e-001 1.750476e+000
 2.308719e-001 1.753330e+000
 2.359268e-001 1.756181e+000
 2.409999e-001 1.759031e+000
 2.460911e-001 1.761879e+000
 2.512008e-001 1.764725e+000
 2.563290e-001 1.767568e+000
 2.614754e-001 1.770409e+000
 2.666405e-001 1.773249e+000
 2.718243e-001 1.776086e+000
 2.770265e-001 1.778920e+000
 2.822476e-001 1.781753e+000
 2.874875e-001 1.784583e+000
 2.927461e-001 1.787410e+000
 2.980238e-001 1.790236e+000
 3.033205e-001 1.793058e+000
 3.086360e-001 1.795878e+000
 3.139709e-001 1.798696e+000
 3.193249e-001 1.801511e+000
 3.246979e-001 1.804323e+000
 3.300905e-001 1.807133e+000
 3.355025e-001 1.809940e+000
 3.409337e-001 1.812744e+000
 3.463846e-001 1.815546e+000

-continued

3.518550e-001	1.818344e+000
3.573449e-001	1.821140e+000
3.628547e-001	1.823933e+000
3.683843e-001	1.826722e+000
3.739335e-001	1.829509e+000
3.795029e-001	1.832293e+000
3.850921e-001	1.835073e+000
3.907012e-001	1.837850e+000
3.963307e-001	1.840624e+000
4.019803e-001	1.843395e+000
4.076498e-001	1.846162e+000
4.133399e-001	1.848926e+000
4.190504e-001	1.851686e+000
4.247810e-001	1.854443e+000
4.365325e-001	1.857197e+000
4.363045e-001	1.859946e+000
4.420968e-001	1.862692e+000
4.479101e-001	1.865435e+000
4.537442e-001	1.868174e+000
4.595989e-001	1.870908e+000
4.654748e-001	1.873640e+000
4.713716e-001	1.876367e+000
4.772892e-001	1.879090e+000
4.832281e-001	1.881809e+000
4.891883e-001	1.884524e+000
4.951694e-001	1.887235e+000
5.011721e-001	1.889941e+000
5.071961e-001	1.892643e+000
5.132414e-001	1.895341e+000
5.193084e-001	1.898035e+000
5.253971e-001	1.900725e+000
5.315071e-001	1.903409e+000
5.376392e-001	1.906090e+000
5.437930e-001	1.908765e+000
5.499684e-001	1.911436e+000
5.561661e-001	1.914102e+000
5.623857e-001	1.916764e+000
5.686271e-001	1.919420e+000
5.748910e-001	1.922072e+000
5.811770e-001	1.924719e+000
5.874851e-001	1.927361e+000
5.938159e-001	1.929997e+000
6.001689e-001	1.932629e+000
6.065442e-001	1.935255e+000
6.129423e-001	1.937876e+000
6.193631e-001	1.940491e+000
6.258063e-001	1.943101e+000
6.322725e-001	1.945706e+000
6.387616e-001	1.948305e+000
6.452733e-001	1.950898e+000
6.518083e-001	1.953485e+000
6.583662e-001	1.956067e+000
6.649470e-001	1.958643e+000
6.715513e-001	1.961213e+000
6.781788e-001	1.963777e+000
6.848294e-001	1.966335e+000
6.915036e-001	1.968887e+000
6.982013e-001	1.971432e+000
7.049223e-001	1.973972e+000
7.116671e-001	1.976505e+000
7.184355e-001	1.979031e+000
7.252275e-001	1.981551e+000
7.320435e-001	1.984064e+000
7.388830e-001	1.986571e+000
7.457468e-001	1.989071e+000
7.526346e-001	1.991564e+000
7.595462e-001	1.994050e+000
7.664821e-001	1.996529e+000
7.734423e-001	1.999001e+000
7.804264e-001	2.001465e+000
7.874352e-001	2.003923e+000
7.944685e-001	2.006373e+000
8.015259e-001	2.008816e+000
8.086082e-001	2.011251e+000
8.133433e-001	2.012870e+000
8.180895e-001	2.014486e+000
8.228464e-001	2.016099e+000
8.276145e-001	2.017708e+000
8.323938e-001	2.019313e+000
8.371840e-001	2.020916e+000

-continued

8.419852e-001	2.022514e+000
8.467972e-001	2.024109e+000
8.516206e-001	2.025700e+000
8.564551e-001	2.027288e+000
8.613009e-001	2.028872e+000
8.661575e-001	2.030453e+000
8.710255e-001	2.032030e+000
8.759047e-001	2.033603e+000
8.807952e-001	2.035172e+000
8.856968e-001	2.036738e+000
8.906095e-001	2.038299e+000
8.955337e-001	2.039857e+000
9.004693e-001	2.041412e+000
9.054163e-001	2.042962e+000
9.103741e-001	2.044508e+000
9.153437e-001	2.046051e+000
9.203247e-001	2.047590e+000
9.253169e-001	2.049124e+000
9.303207e-001	2.050655e+000
9.353356e-001	2.052181e+000
9.403626e-001	2.053704e+000
9.454000e-001	2.055222e+000
9.504496e-001	2.056736e+000
9.555107e-001	2.058246e+000
9.605832e-001	2.059751e+000
9.656674e-001	2.061253e+000
9.707631e-001	2.062750e+000
9.758704e-001	2.064243e+000
9.809893e-001	2.065732e+000
9.861199e-001	2.067216e+000
9.912614e-001	2.068696e+000
9.964152e-001	2.070172e+000
1.001581e+000	2.071643e+000
1.006758e+000	2.073109e+000
1.011947e+000	2.074572e+000
1.017148e+000	2.076029e+000
1.022360e+000	2.077482e+000
1.027584e+000	2.078931e+000
1.032820e+000	2.080374e+000
1.038067e+000	2.081813e+000
1.043327e+000	2.083248e+000
1.048598e+000	2.084677e+000
1.053881e+000	2.086103e+000
1.059177e+000	2.087523e+000
1.064484e+000	2.088938e+000
1.069803e+000	2.090349e+000
1.075133e+000	2.091754e+000
1.080476e+000	2.093155e+000
1.085830e+000	2.094551e+000
1.091197e+000	2.095942e+000
1.096576e+000	2.097328e+000
1.101967e+000	2.098708e+000
1.107370e+000	2.100084e+000
1.112785e+000	2.101455e+000
1.118212e+000	2.102820e+000
1.123651e+000	2.104180e+000
1.129102e+000	2.105535e+000
1.134564e+000	2.106885e+000
1.140040e+000	2.108229e+000
1.145527e+000	2.109568e+000
1.151027e+000	2.110902e+000
1.156539e+000	2.112230e+000
1.162063e+000	2.113553e+000
1.167599e+000	2.114871e+000
1.173148e+000	2.116183e+000
1.178708e+000	2.117489e+000
1.184281e+000	2.118790e+000
1.189866e+000	2.120085e+000
1.195464e+000	2.121375e+000
1.201074e+000	2.122659e+000
1.206696e+000	2.123937e+000
1.212331e+000	2.125209e+000
1.217977e+000	2.126476e+000
1.223637e+000	2.127736e+000
1.229308e+000	2.128991e+000
1.234992e+000	2.130240e+000
1.240688e+000	2.131483e+000
1.246397e+000	2.132720e+000
1.252118e+000	2.133950e+000
1.257852e+000	2.135175e+000

-continued

1.263598e+000	2.136394e+000
1.269357e+000	2.137606e+000
1.275128e+000	2.138813e+000
1.280912e+000	2.140013e+000
1.286708e+000	2.141207e+000
1.292516e+000	2.142394e+000
1.298338e+000	2.143575e+000
1.304172e+000	2.144750e+000
1.310018e+000	2.145918e+000
1.315877e+000	2.147080e+000
1.321749e+000	2.148236e+000
1.327633e+000	2.149384e+000
1.333530e+000	2.150527e+000
1.339439e+000	2.151662e+000
1.345361e+000	2.152791e+000
1.351296e+000	2.153913e+000
1.357244e+000	2.155029e+000
1.363204e+000	2.156137e+000
1.369177e+000	2.157239e+000
1.375162e+000	2.158334e+000
1.381161e+000	2.159422e+000
1.387171e+000	2.160503e+000
1.393195e+000	2.161577e+000
1.399232e+000	2.162644e+000
1.405281e+000	2.163704e+000
1.411343e+000	2.164756e+000
1.417418e+000	2.165802e+000
1.423506e+000	2.166840e+000
1.429607e+000	2.167871e+000
1.435720e+000	2.168895e+000
1.441845e+000	2.169911e+000
1.447984e+000	2.170920e+000
1.454136e+000	2.171921e+000
1.460301e+000	2.172915e+000
1.466478e+000	2.173901e+000
1.472669e+000	2.174880e+000
1.478872e+000	2.175851e+000
1.485088e+000	2.176815e+000
1.491317e+000	2.177770e+000
1.497559e+000	2.178718e+000
1.503814e+000	2.179658e+000
1.510081e+000	2.180591e+000
1.516362e+000	2.181515e+000
1.522656e+000	2.182431e+000
1.528962e+000	2.183340e+000
1.535282e+000	2.184240e+000
1.541615e+000	2.185132e+000
1.547960e+000	2.186016e+000
1.554318e+000	2.186892e+000
1.560689e+000	2.187759e+000
1.567073e+000	2.188618e+000
1.573470e+000	2.189469e+000
1.579881e+000	2.190311e+000
1.586304e+000	2.191145e+000
1.592740e+000	2.191971e+000
1.599190e+000	2.192788e+000
1.605652e+000	2.193596e+000
1.612126e+000	2.194396e+000
1.618614e+000	2.195186e+000
1.625116e+000	2.195969e+000
1.631630e+000	2.196742e+000
1.638157e+000	2.197507e+000
1.644698e+000	2.198263e+000
1.651251e+000	2.199009e+000
1.657818e+000	2.199747e+000
1.664397e+000	2.200476e+000
1.670989e+000	2.201195e+000
1.677594e+000	2.201906e+000
1.684213e+000	2.202607e+000
1.690844e+000	2.203299e+000
1.697489e+000	2.203981e+000
1.704146e+000	2.204654e+000
1.710817e+000	2.205318e+000
1.717501e+000	2.205972e+000
1.724197e+000	2.206617e+000
1.730906e+000	2.207252e+000
1.737629e+000	2.207878e+000
1.744364e+000	2.208493e+000
1.751113e+000	2.209099e+000
1.757874e+000	2.209695e+000

-continued

1.764649e+000	2.210281e+000
1.771437e+000	2.210858e+000
1.778237e+000	2.211424e+000
1.785051e+000	2.211981e+000
1.791878e+000	2.212527e+000
1.798717e+000	2.213063e+000
1.805570e+000	2.213589e+000
1.812436e+000	2.214105e+000
1.819314e+000	2.214610e+000
1.826206e+000	2.215105e+000
1.833111e+000	2.215590e+000
1.840028e+000	2.216064e+000
1.846959e+000	2.216528e+000
1.853902e+000	2.216981e+000
1.860858e+000	2.217423e+000
1.867827e+000	2.217855e+000
1.874810e+000	2.218276e+000
1.881805e+000	2.218686e+000
1.888813e+000	2.219085e+000
1.895834e+000	2.219473e+000
1.902868e+000	2.219850e+000
1.909915e+000	2.220217e+000
1.916974e+000	2.220572e+000
1.924047e+000	2.220916e+000
1.931133e+000	2.221249e+000
1.938231e+000	2.221570e+000
1.945342e+000	2.221881e+000
1.952466e+000	2.222179e+000
1.959603e+000	2.222467e+000
1.966753e+000	2.222742e+000
1.973915e+000	2.223006e+000
1.981089e+000	2.223258e+000
1.988277e+000	2.223499e+000
1.995478e+000	2.223728e+000
2.002691e+000	2.223945e+000
2.009917e+000	2.224150e+000
2.017156e+000	2.224343e+000
2.024407e+000	2.224524e+000
2.031672e+000	2.224693e+000
2.038948e+000	2.224850e+000
2.046237e+000	2.224995e+000
2.053539e+000	2.225127e+000
2.060854e+000	2.225247e+000
2.068181e+000	2.225355e+000
2.075521e+000	2.225451e+000
2.082873e+000	2.225533e+000
2.090238e+000	2.225603e+000
2.097615e+000	2.225661e+000
2.105005e+000	2.225705e+000
2.112406e+000	2.225737e+000
2.119821e+000	2.225756e+000
2.127248e+000	2.225762e+000
2.134688e+000	2.225755e+000
2.142139e+000	2.225735e+000
2.145869e+000	2.225720e+000

Looking at the z and y coordinates reproduced above, the first number in each pair of coordinates is the z axis coordinate with zero at the focal point. The second number is the y axis coordinate. The first number in the above list, for example, comprises a y value of 0.3 resulting in a 0.6 inch diameter hole at the base of the illumination reflector **77**. The final y value in the above list is over 2 inches resulting in a diameter of the illumination reflector **77** of about 4.5 inches. The focal point **129** of the illumination reflector **77** corresponds to the point 2.481236e-005, 1.608924e+000 in the above-list of coordinates. The computer-generated curvature of the illumination reflector **77** of the presently preferred embodiment is capable of generating improvements in luminous flux over conventional illumination reflectors.

Referring again particularly to FIGS. 1 and 2, reference numeral **14** denotes an exemplary non-conic illumination reflector which might be generated using the method described above. Reference numeral **14a** denotes, in contrast, a classic conic illumination reflector, having a

circular cross section (FIG. 2) which might be used in the prior art. The deviation of the shape of reflector 14 from a surface of revolution of a classic conic section has been exaggerated for illustrative purposes.

Another advantage of the non-conic illumination reflector 14 designed and fabricated in accordance with the principles of this invention is the ability to utilize higher intensity light at the fiber or pipe end face without burning the fiber or pipe ends. Optical beams do not naturally have a uniform intensity distribution across the beam. Imperfections in optical systems can produce peaks and other nonuniformities. Even in ideal systems the intensity distribution will tend toward a Gaussian distribution. A Gaussian beam has a peaked distribution described by

$$I=e^{-x} \quad (2)$$

where I is the intensity of the beam and x is the distance from the center of the beam. Lasers are naturally Gaussian. Other light beams will approach Gaussian as they are diffracted in an optical system.

The existence of intensity peaks when light is launched into an optical fiber can result in fiber burning. This in turn limits the maximum power that can be safely launched into a fiber. For example, when a beam of light is directed onto the end of a bundle of fibers the center fiber(s) tend to burn because intensity of the light is peaked near the center.

The non-conic illumination reflector shapes generated by the inventive methods not only compensate for the shape of the lamp but also produce a more uniform intensity distribution at the fiber end face. This permits the safe use of higher intensity levels without burning the fiber ends.

It should be noted that this technique for mapping the radiation patterns of a light source, and developing a database from which a reflector may be designed for an illumination system, is not limited to fiber optic applications. It is also useful for other types of illumination applications, such as projection systems, for example. Furthermore, the database which is developed from the mapping process may be used to fabricate customized lenses as well as reflectors, if desired.

Although exemplary embodiments of the invention have been shown and described, many changes, modifications and substitutions may be made by one having ordinary skill in the art without necessarily departing from the spirit and scope of this invention.

We claim:

1. An illumination system, comprising:
 - an illumination source;
 - at least one color wheel adapted for receiving light from the illumination source; and
 - an illumination reflector having a computer-generated reflecting surface, the illumination reflector having a non-circular cross-section and being non-elliptical and non-parabolic, and being adapted for receiving illumination from the illumination source and redirecting the illumination to the color wheel.
2. The illumination system as recited in claim 1, the color wheel comprising a DMX addressable color changer, and the illumination source comprising a 175 watt halogen bulb.
3. The illumination system as recited in claim 1, the color wheel comprising a DMX addressable color changer, and the illumination source comprising a 200 watt halogen bulb.
4. The illumination system as recited in claim 1, further comprising a homogenizer lens assembly adapted for receiving light from the illumination source, and the computer

generated reflecting surface increasing a luminous flux of the illumination system.

5. The illumination system as recited in claim 3, further comprising at least one optical fiber adapted for receiving light from the homogenizer lens assembly.

6. The illumination system as recited in claim 5, the at least one optical fiber comprising a bundle of optical fibers.

7. The illumination system as recited in claim 1, the illumination reflector comprising nickel.

8. The illumination system as recited in claim 6, the illumination reflector being manufactured by at least one of nickel forming and spinning.

9. The illumination system as recited in claim 1, the computer-generated reflecting surface comprising a curved surface.

10. An illumination system, comprising:

an illumination source;

at least one color wheel adapted for receiving light from the illumination source; and

an illumination reflector having a computer-generated curve, the illumination reflector having a non-circular cross-section and being non-elliptical and non-parabolic, the illumination reflector being adapted for receiving illumination from the illumination source and redirecting the illumination to the color wheel.

11. The illumination system as recited in claim 10, the illumination reflector being adapted for redirecting substantially a maximum amount of the illumination to the color wheel, and further comprising a homogenizer lens assembly for receiving light from the color wheel.

12. The illumination system as recited in claim 10, further comprising at least one optical fiber adapted for receiving light from the homogenizer lens assembly.

13. An illumination reflector adapted for use in an illumination system, the illumination system having an illumination source, at least one color wheel adapted for receiving light from the illumination source, and a homogenizer lens assembly adapted for receiving light from the color wheel, the illumination reflector comprising:

a non-circular cross-section; and

a computer-generated reflecting surface adapted for maximizing reflections of radiation patterns of the illumination source into the color wheel, the computer-generated reflecting surface being based on both measured radiation patterns of the illumination source and computer simulations of different reflecting surfaces for maximizing the reflections of the radiation patterns into the color wheel.

14. The illumination reflector as recited in claim 13, further being adapted for receiving illumination from the illumination source and redirecting the illumination to the color wheel.

15. The illumination reflector as recited in claim 13, the illumination reflector having a non-circular cross-section and being non-elliptical and non-parabolic.

16. The illumination system as recited in claim 13, the computer generated reflecting surface increasing a luminous flux of the illumination system, and further comprising at least one of an optical fiber and a bundle of optical fibers adapted for receiving light from the homogenizer lens assembly.

17. The illumination system as recited in claim 13, the illumination source comprising a 175 watt halogen bulb.

18. The illumination system as recited in claim 13, the illumination source comprising a 200 watt halogen bulb.

19. An illumination reflector adapted for maximizing reflections from an illumination source onto a target surface,

the illumination reflector having a reflecting surface that can be expressed in z and y coordinates, the y-coordinates being measured along an axis that extends perpendicularly to a portion of the reflecting surface and through the illumination source, and the z-coordinates expressing radial distances from the y axis, the z and y coordinates of the reflecting surface comprising the following specific z and y values, respectively, with a plus or minus twenty percent tolerance for each specific value:

-9.233051e - 001	3.000000e - 001
-9.223477e - 001	3.050373e - 001
-9.213737e - 001	3.100762e - 001
-9.203830e - 001	3.151173e - 001
-9.193758e - 001	3.201601e - 001
-9.183519e - 001	3.252051e - 001
-9.173112e - 001	3.302519e - 001
-9.162537e - 001	3.353006e - 001
-9.151795e - 001	3.403517e - 001
-9.140885e - 001	3.454044e - 001
-9.129804e - 001	3.504596e - 001
-9.118558e - 001	3.555168e - 001
-9.107137e - 001	3.605759e - 001
-9.095548e - 001	3.656376e - 001
-9.083787e - 001	3.707013e - 001
-9.071855e - 001	3.757674e - 001
-9.059753e - 001	3.808354e - 001
-9.047478e - 001	3.859062e - 001
-9.035031e - 001	3.909791e - 001
-9.022409e - 001	3.960544e - 001
-9.009613e - 001	4.011321e - 001
-8.996643e - 001	4.062121e - 001
-8.983498e - 001	4.112947e - 001
-8.970177e - 001	4.163798e - 001
-8.956681e - 001	4.214673e - 001
-8.943009e - 001	4.265575e - 001
-8.929159e - 001	4.316501e - 001
-8.915132e - 001	4.367454e - 001
-8.900926e - 001	4.418433e - 001
-8.886542e - 001	4.469439e - 001
-8.871978e - 001	4.520473e - 001
-8.857234e - 001	4.571531e - 001
-8.842309e - 001	4.622618e - 001
-8.827202e - 001	4.673732e - 001
-8.811914e - 001	4.724876e - 001
-8.796443e - 001	4.776047e - 001
-8.780789e - 001	4.827247e - 001
-8.764951e - 001	4.878476e - 001
-8.748929e - 001	4.929732e - 001
-8.732721e - 001	4.981020e - 001
-8.716325e - 001	5.032336e - 001
-8.699744e - 001	5.083683e - 001
-8.682976e - 001	5.135059e - 001
-8.666021e - 001	5.186465e - 001
-8.648875e - 001	5.237904e - 001
-8.631541e - 001	5.289372e - 001
-8.614016e - 001	5.340872e - 001
-8.596301e - 001	5.392405e - 001
-8.578394e - 001	5.443968e - 001
-8.560294e - 001	5.495564e - 001
-8.542002e - 001	5.547192e - 001
-8.523515e - 001	5.598854e - 001
-8.504834e - 001	5.650548e - 001
-8.485957e - 001	5.702275e - 001
-8.466883e - 001	5.754034e - 001
-8.447612e - 001	5.805828e - 001
-8.428143e - 001	5.857655e - 001
-8.408476e - 001	5.909519e - 001
-8.388608e - 001	5.961415e - 001
-8.368539e - 001	6.013345e - 001
-8.348268e - 001	6.065311e - 001
-8.327798e - 001	6.117314e - 001
-8.307123e - 001	6.169351e - 001
-8.286244e - 001	6.221422e - 001
-8.265160e - 001	6.273532e - 001
-8.243871e - 001	6.325676e - 001
-8.222374e - 001	6.377859e - 001
-8.200670e - 001	6.430076e - 001

-continued

-8.178757e - 001	6.482331e - 001
-8.156635e - 001	6.534624e - 001
-8.134302e - 001	6.586952e - 001
-8.111757e - 001	6.639320e - 001
-8.089000e - 001	6.691725e - 001
-8.066029e - 001	6.744168e - 001
-8.042844e - 001	6.796650e - 001
-8.019444e - 001	6.849169e - 001
-7.995827e - 001	6.901728e - 001
-7.971994e - 001	6.954326e - 001
-7.947941e - 001	7.006965e - 001
-7.923669e - 001	7.059641e - 001
-7.899176e - 001	7.112359e - 001
-7.874461e - 001	7.165115e - 001
-7.849525e - 001	7.217912e - 001
-7.824362e - 001	7.270749e - 001
-7.798976e - 001	7.323627e - 001
-7.773362e - 001	7.376544e - 001
-7.747521e - 001	7.429504e - 001
-7.721453e - 001	7.482504e - 001
-7.695155e - 001	7.535546e - 001
-7.668629e - 001	7.588632e - 001
-7.641869e - 001	7.641759e - 001
-7.614874e - 001	7.694926e - 001
-7.587646e - 001	7.748135e - 001
-7.560183e - 001	7.801387e - 001
-7.537116e - 001	7.854798e - 001
-7.513885e - 001	7.890238e - 001
-7.490488e - 001	7.934707e - 001
-7.466925e - 001	7.979207e - 001
-7.443193e - 001	8.023735e - 001
-7.419294e - 001	8.068295e - 001
-7.395225e - 001	8.112884e - 001
-7.370989e - 001	8.157505e - 001
-7.346582e - 001	8.202154e - 001
-7.322002e - 001	8.246835e - 001
-7.297251e - 001	8.291546e - 001
-7.272329e - 001	8.336289e - 001
-7.247231e - 001	8.381059e - 001
-7.221960e - 001	8.425863e - 001
-7.196514e - 001	8.470696e - 001
-7.170892e - 001	8.515562e - 001
-7.145095e - 001	8.560460e - 001
-7.119121e - 001	8.605387e - 001
-7.092968e - 001	8.650347e - 001
-7.066635e - 001	8.695338e - 001
-7.040124e - 001	8.740359e - 001
-7.013431e - 001	8.785412e - 001
-6.986557e - 001	8.830498e - 001
-6.959500e - 001	8.875615e - 001
-6.932261e - 001	8.920763e - 001
-6.904837e - 001	8.965944e - 001
-6.877229e - 001	9.011157e - 001
-6.849435e - 001	9.056401e - 001
-6.821454e - 001	9.101678e - 001
-6.793285e - 001	9.146987e - 001
-6.764928e - 001	9.192327e - 001
-6.736381e - 001	9.237698e - 001
-6.707643e - 001	9.283103e - 001
-6.678716e - 001	9.328540e - 001
-6.649595e - 001	9.374009e - 001
-6.620281e - 001	9.419510e - 001
-6.590773e - 001	9.465044e - 001
-6.561070e - 001	9.510610e - 001
-6.531172e - 001	9.556208e - 001
-6.501076e - 001	9.601840e - 001
-6.470782e - 001	9.647504e - 001
-6.440291e - 001	9.693201e - 001
-6.409597e - 001	9.738930e - 001
-6.378705e - 001	9.784693e - 001
-6.347611e - 001	9.830488e - 001
-6.316313e - 001	9.876316e - 001
-6.284812e - 001	9.922174e - 001
-6.253105e - 001	9.968067e - 001
-6.221192e - 001	1.001399e + 000
-6.189073e - 001	1.005995e + 000
-6.156746e - 001	1.010594e + 000
-6.124209e - 001	1.015197e + 000
-6.091463e - 001	1.019802e + 000
-6.058505e - 001	1.024411e + 000

-continued

-6.025335e - 001	1.029024e + 000	
-5.991952e - 001	1.033639e + 000	
-5.958354e - 001	1.038258e + 000	
-5.924541e - 001	1.042880e + 000	5
-5.890511e - 001	1.047506e + 000	
-5.856262e - 001	1.052134e + 000	
-5.821796e - 001	1.056766e + 000	
-5.787108e - 001	1.061401e + 000	
-5.752199e - 001	1.066040e + 000	
-5.717068e - 001	1.070681e + 000	10
-5.681713e - 001	1.075327e + 000	
-5.646135e - 001	1.079975e + 000	
-5.610331e - 001	1.084626e + 000	
-5.574298e - 001	1.089281e + 000	
-5.538036e - 001	1.093939e + 000	
-5.501546e - 001	1.098600e + 000	15
-5.464825e - 001	1.103265e + 000	
-5.427871e - 001	1.107932e + 000	
-5.390684e - 001	1.112603e + 000	
-5.353261e - 001	1.117278e + 000	
-5.315600e - 001	1.121955e + 000	
-5.277704e - 001	1.126636e + 000	
-5.239570e - 001	1.131320e + 000	20
-5.201197e - 001	1.136007e + 000	
-5.162581e - 001	1.140698e + 000	
-5.123724e - 001	1.145391e + 000	
-5.084624e - 001	1.150088e + 000	
-5.045278e - 001	1.154788e + 000	
-5.005687e - 001	1.159491e + 000	25
-4.965849e - 001	1.164197e + 000	
-4.925762e - 001	1.168907e + 000	
-4.885423e - 001	1.173619e + 000	
-4.844834e - 001	1.178334e + 000	
-4.803991e - 001	1.183053e + 000	
-4.771134e - 001	1.186830e + 000	30
-4.738113e - 001	1.190609e + 000	
-4.704929e - 001	1.194390e + 000	
-4.671579e - 001	1.198172e + 000	
-4.638065e - 001	1.201957e + 000	
-4.604383e - 001	1.205744e + 000	
-4.570535e - 001	1.209532e + 000	35
-4.536518e - 001	1.213323e + 000	
-4.502332e - 001	1.217115e + 000	
-4.467977e - 001	1.220909e + 000	
-4.433452e - 001	1.224706e + 000	
-4.398757e - 001	1.228504e + 000	
-4.363889e - 001	1.232304e + 000	
-4.328850e - 001	1.236105e + 000	40
-4.293637e - 001	1.239909e + 000	
-4.258251e - 001	1.243714e + 000	
-4.222689e - 001	1.247521e + 000	
-4.186952e - 001	1.251330e + 000	
-4.151039e - 001	1.255141e + 000	
-4.114947e - 001	1.258954e + 000	45
-4.078680e - 001	1.262768e + 000	
-4.042232e - 001	1.266584e + 000	
-4.005606e - 001	1.270402e + 000	
-3.968799e - 001	1.274221e + 000	
-3.931811e - 001	1.278042e + 000	
-3.894641e - 001	1.281865e + 000	50
-3.857289e - 001	1.285690e + 000	
-3.819752e - 001	1.289516e + 000	
-3.782030e - 001	1.293344e + 000	
-3.744125e - 001	1.297174e + 000	
-3.706032e - 001	1.301005e + 000	
-3.667753e - 001	1.304838e + 000	55
-3.629286e - 001	1.308673e + 000	
-3.590630e - 001	1.312509e + 000	
-3.551784e - 001	1.316347e + 000	
-3.512750e - 001	1.320186e + 000	
-3.473522e - 001	1.324027e + 000	
-3.434103e - 001	1.327869e + 000	
-3.394491e - 001	1.331713e + 000	60
-3.354684e - 001	1.335558e + 000	
-3.314684e - 001	1.339405e + 000	
-3.274487e - 001	1.343253e + 000	
-3.234094e - 001	1.347103e + 000	
-3.193502e - 001	1.350954e + 000	
-3.152713e - 001	1.354807e + 000	65
-3.111724e - 001	1.358661e + 000	

-continued

-3.070536e - 001	1.362516e + 000
-3.029145e - 001	1.366373e + 000
-2.987552e - 001	1.370231e + 000
-2.945757e - 001	1.374090e + 000
-2.903756e - 001	1.377950e + 000
-2.861553e - 001	1.381812e + 000
-2.819141e - 001	1.385675e + 000
-2.776525e - 001	1.389539e + 000
-2.733699e - 001	1.393405e + 000
-2.690665e - 001	1.397271e + 000
-2.647421e - 001	1.401139e + 000
-2.603965e - 001	1.405008e + 000
-2.560300e - 001	1.408877e + 000
-2.516420e - 001	1.412749e + 000
-2.472328e - 001	1.416620e + 000
-2.428019e - 001	1.420493e + 000
-2.383497e - 001	1.424368e + 000
-2.338756e - 001	1.428243e + 000
-2.293799e - 001	1.432119e + 000
-2.248621e - 001	1.435996e + 000
-2.203224e - 001	1.439873e + 000
-2.157608e - 001	1.443752e + 000
-2.111768e - 001	1.447631e + 000
-2.065707e - 001	1.451512e + 000
-2.019420e - 001	1.455393e + 000
-1.972910e - 001	1.459275e + 000
-1.926172e - 001	1.463157e + 000
-1.879208e - 001	1.467040e + 000
-1.832015e - 001	1.470924e + 000
-1.784592e - 001	1.474808e + 000
-1.736941e - 001	1.478693e + 000
-1.689056e - 001	1.482579e + 000
-1.640942e - 001	1.486465e + 000
-1.592591e - 001	1.490351e + 000
-1.544008e - 001	1.494238e + 000
-1.495187e - 001	1.498126e + 000
-1.446131e - 001	1.502014e + 000
-1.396835e - 001	1.505902e + 000
-1.347299e - 001	1.509791e + 000
-1.297525e - 001	1.513679e + 000
-1.247508e - 001	1.517568e + 000
-1.197250e - 001	1.521457e + 000
-1.146747e - 001	1.525347e + 000
-1.096000e - 001	1.529236e + 000
-1.045006e - 001	1.533126e + 000
-9.937663e - 002	1.537015e + 000
-9.422766e - 002	1.540905e + 000
-8.905388e - 002	1.544794e + 000
-8.385488e - 002	1.548684e + 000
-7.863066e - 002	1.552573e + 000
-7.338132e - 002	1.556462e + 000
-6.810638e - 002	1.560351e + 000
-6.280605e - 002	1.564240e + 000
-5.747988e - 002	1.568128e + 000
-5.212810e - 002	1.572016e + 000
-4.675021e - 002	1.575903e + 000
-4.134648e - 002	1.579790e + 000
-3.727638e - 002	1.582705e + 000
-3.319151e - 002	1.585620e + 000
-2.909201e - 002	1.588534e + 000
-2.497745e - 002	1.591448e + 000
-2.084796e - 002	1.594362e + 000
-1.670369e - 002	1.597275e + 000
-1.254420e - 002	1.600188e + 000
-8.369619e - 003	1.603101e + 000
-4.180094e - 003	1.606013e + 000
2.481236e - 005	1.608924e + 000
4.244964e - 003	1.611835e + 000
8.480221e - 003	1.614746e + 000
1.273102e - 002	1.617656e + 000
1.699724e - 002	1.620565e + 000
2.127871e - 002	1.623474e + 000
2.557590e - 002	1.626382e + 000
2.988866e - 002	1.629290e + 000
3.421685e - 002	1.632197e + 000
3.856092e - 002	1.635103e + 000
4.292073e - 002	1.638008e + 000
4.729613e - 002	1.640913e + 000
5.168757e - 002	1.643817e + 000
5.609492e - 002	1.646721e + 000

-continued

6.051803e - 002	1.649623e + 000	
6.495736e - 002	1.652524e + 000	
6.941275e - 002	1.655425e + 000	
7.388408e - 002	1.658325e + 000	5
7.837179e - 002	1.661224e + 000	
8.287575e - 002	1.664122e + 000	
8.739579e - 002	1.667018e + 000	
9.193241e - 002	1.669914e + 000	
9.648544e - 002	1.672809e + 000	
1.010547e - 001	1.675703e + 000	10
1.056408e - 001	1.678596e + 000	
1.102434e - 001	1.681488e + 000	
1.148625e - 001	1.684378e + 000	
1.194984e - 001	1.687268e + 000	
1.241512e - 001	1.690156e + 000	
1.288205e - 001	1.693043e + 000	
1.335070e - 001	1.695929e + 000	15
1.382104e - 001	1.698813e + 000	
1.429305e - 001	1.701696e + 000	
1.476680e - 001	1.704578e + 000	
1.524225e - 001	1.707458e + 000	
1.571941e - 001	1.710337e + 000	
1.619831e - 001	1.713215e + 000	20
1.667894e - 001	1.716091e + 000	
1.716128e - 001	1.718965e + 000	
1.764539e - 001	1.721838e + 000	
1.813124e - 001	1.724710e + 000	
1.861883e - 001	1.727579e + 000	
1.910820e - 001	1.730448e + 000	25
1.959933e - 001	1.733314e + 000	
2.009222e - 001	1.736179e + 000	
2.058690e - 001	1.739042e + 000	
2.108338e - 001	1.741903e + 000	
2.158162e - 001	1.744762e + 000	
2.208168e - 001	1.747620e + 000	30
2.258354e - 001	1.750476e + 000	
2.308719e - 001	1.753330e + 000	
2.359268e - 001	1.756181e + 000	
2.409999e - 001	1.759031e + 000	
2.460911e - 001	1.761879e + 000	
2.512008e - 001	1.764725e + 000	35
2.563290e - 001	1.767568e + 000	
2.614754e - 001	1.770409e + 000	
2.666405e - 001	1.773249e + 000	
2.718243e - 001	1.776086e + 000	
2.770265e - 001	1.778920e + 000	
2.822476e - 001	1.781753e + 000	40
2.874875e - 001	1.784583e + 000	
2.927461e - 001	1.787410e + 000	
2.980238e - 001	1.790236e + 000	
3.033205e - 001	1.793058e + 000	
3.086360e - 001	1.795878e + 000	
3.139709e - 001	1.798696e + 000	45
3.193249e - 001	1.801511e + 000	
3.246979e - 001	1.804323e + 000	
3.300905e - 001	1.807133e + 000	
3.355025e - 001	1.809940e + 000	
3.409337e - 001	1.812744e + 000	
3.463846e - 001	1.815546e + 000	50
3.518550e - 001	1.818344e + 000	
3.573449e - 001	1.821140e + 000	
3.628547e - 001	1.823933e + 000	
3.683843e - 001	1.826722e + 000	
3.739335e - 001	1.829509e + 000	
3.795029e - 001	1.832293e + 000	
3.850921e - 001	1.835073e + 000	55
3.907012e - 001	1.837850e + 000	
3.963307e - 001	1.840624e + 000	
4.019803e - 001	1.843395e + 000	
4.076498e - 001	1.846162e + 000	
4.133399e - 001	1.848926e + 000	60
4.190504e - 001	1.851686e + 000	
4.247810e - 001	1.854443e + 000	
4.305325e - 001	1.857197e + 000	
4.363045e - 001	1.859946e + 000	
4.420968e - 001	1.862692e + 000	
4.479101e - 001	1.865435e + 000	
4.537442e - 001	1.868174e + 000	
4.595989e - 001	1.870908e + 000	65
4.654748e - 001	1.873640e + 000	

-continued

4.713716e - 001	1.876367e + 000	
4.772892e - 001	1.879090e + 000	
4.832281e - 001	1.881809e + 000	
4.891883e - 001	1.884524e + 000	
4.951694e - 001	1.887235e + 000	
5.011721e - 001	1.889941e + 000	
5.071961e - 001	1.892643e + 000	
5.132414e - 001	1.895341e + 000	
5.193084e - 001	1.898035e + 000	
5.253971e - 001	1.900725e + 000	
5.315071e - 001	1.903409e + 000	
5.376392e - 001	1.906090e + 000	
5.437930e - 001	1.908765e + 000	
5.499684e - 001	1.911436e + 000	
5.561661e - 001	1.914102e + 000	
5.623857e - 001	1.916764e + 000	
5.686271e - 001	1.919420e + 000	
5.748910e - 001	1.922072e + 000	
5.811770e - 001	1.924719e + 000	
5.874851e - 001	1.927361e + 000	
5.938159e - 001	1.929997e + 000	
6.001689e - 001	1.932629e + 000	
6.065442e - 001	1.935255e + 000	
6.129423e - 001	1.937876e + 000	
6.193631e - 001	1.940491e + 000	
6.258063e - 001	1.943101e + 000	
6.322725e - 001	1.945706e + 000	
6.387616e - 001	1.948305e + 000	
6.452733e - 001	1.950898e + 000	
6.518083e - 001	1.953485e + 000	
6.583662e - 001	1.956067e + 000	
6.649470e - 001	1.958643e + 000	
6.715513e - 001	1.961213e + 000	
6.781788e - 001	1.963777e + 000	
6.848294e - 001	1.966335e + 000	
6.915036e - 001	1.968887e + 000	
6.982013e - 001	1.971432e + 000	
7.049223e - 001	1.973972e + 000	
7.116671e - 001	1.976505e + 000	
7.184355e - 001	1.979031e + 000	
7.252275e - 001	1.981551e + 000	
7.320435e - 001	1.984064e + 000	
7.388830e - 001	1.986571e + 000	
7.457468e - 001	1.989071e + 000	
7.526346e - 001	1.991564e + 000	
7.595462e - 001	1.994050e + 000	
7.664821e - 001	1.996529e + 000	
7.734423e - 001	1.999001e + 000	
7.804264e - 001	2.001465e + 000	
7.874352e - 001	2.003923e + 000	
7.944685e - 001	2.006373e + 000	
8.015259e - 001	2.008816e + 000	
8.086082e - 001	2.011251e + 000	
8.133433e - 001	2.012870e + 000	
8.180895e - 001	2.014486e + 000	
8.228464e - 001	2.016099e + 000	
8.276145e - 001	2.017708e + 000	
8.323938e - 001	2.019313e + 000	
8.371840e - 001	2.020916e + 000	
8.419852e - 001	2.022514e + 000	
8.467972e - 001	2.024109e + 000	
8.516206e - 001	2.025700e + 000	
8.564551e - 001	2.027288e + 000	
8.613009e - 001	2.028872e + 000	
8.661575e - 001	2.030453e + 000	
8.710255e - 001	2.032030e + 000	
8.759047e - 001	2.033603e + 000	
8.807952e - 001	2.035172e + 000	
8.856968e - 001	2.036738e + 000	
8.906095e - 001	2.038299e + 000	
8.955337e - 001	2.039857e + 000	
9.004693e - 001	2.041412e + 000	
9.054163e - 001	2.042962e + 000	
9.103741e - 001	2.044508e + 000	
9.153437e - 001	2.046051e + 000	
9.203247e - 001	2.047590e + 000	
9.253169e - 001	2.049124e + 000	
9.303207e - 001	2.050655e + 000	
9.353356e - 001	2.052181e + 000	
9.403626e - 001	2.053704e + 000	

-continued

9.454000e - 001	2.055222e + 000
9.504496e - 001	2.056736e + 000
9.555107e - 001	2.058246e + 000
9.605832e - 001	2.059751e + 000
9.656674e - 001	2.061253e + 000
9.707631e - 001	2.062750e + 000
9.758704e - 001	2.064243e + 000
9.809893e - 001	2.065732e + 000
9.861199e - 001	2.067216e + 000
9.912614e - 001	2.068696e + 000
9.964152e - 001	2.070172e + 000
1.001581e + 000	2.071643e + 000
1.006758e + 000	2.073109e + 000
1.011947e + 000	2.074572e + 000
1.017148e + 000	2.076029e + 000
1.022360e + 000	2.077482e + 000
1.027584e + 000	2.078931e + 000
1.032820e + 000	2.080374e + 000
1.038067e + 000	2.081813e + 000
1.043327e + 000	2.083248e + 000
1.048598e + 000	2.084677e + 000
1.053881e + 000	2.086103e + 000
1.059177e + 000	2.087523e + 000
1.064484e + 000	2.088938e + 000
1.069803e + 000	2.090349e + 000
1.075133e + 000	2.091754e + 000
1.080476e + 000	2.093155e + 000
1.085830e + 000	2.094551e + 000
1.091197e + 000	2.095942e + 000
1.096576e + 000	2.097328e + 000
1.101967e + 000	2.098708e + 000
1.107370e + 000	2.100084e + 000
1.112785e + 000	2.101455e + 000
1.118212e + 000	2.102820e + 000
1.123651e + 000	2.104180e + 000
1.129102e + 000	2.105535e + 000
1.134564e + 000	2.106885e + 000
1.140040e + 000	2.108229e + 000
1.145527e + 000	2.109568e + 000
1.151027e + 000	2.110902e + 000
1.156539e + 000	2.112230e + 000
1.162063e + 000	2.113553e + 000
1.167599e + 000	2.114871e + 000
1.173148e + 000	2.116183e + 000
1.178708e + 000	2.117489e + 000
1.184281e + 000	2.118790e + 000
1.189866e + 000	2.120085e + 000
1.195464e + 000	2.121375e + 000
1.201074e + 000	2.122659e + 000
1.206696e + 000	2.123937e + 000
1.212331e + 000	2.125209e + 000
1.217977e + 000	2.126476e + 000
1.223637e + 000	2.127736e + 000
1.229308e + 000	2.128991e + 000
1.234992e + 000	2.130240e + 000
1.240688e + 000	2.131483e + 000
1.246397e + 000	2.132720e + 000
1.252118e + 000	2.133950e + 000
1.257852e + 000	2.135175e + 000
1.263598e + 000	2.136394e + 000
1.269357e + 000	2.137606e + 000
1.275128e + 000	2.138813e + 000
1.280912e + 000	2.140013e + 000
1.286708e + 000	2.141207e + 000
1.292516e + 000	2.142394e + 000
1.298338e + 000	2.143575e + 000
1.304172e + 000	2.144750e + 000
1.310018e + 000	2.145918e + 000
1.315877e + 000	2.147080e + 000
1.321749e + 000	2.148236e + 000
1.327633e + 000	2.149384e + 000
1.333530e + 000	2.150527e + 000
1.339439e + 000	2.151662e + 000
1.345361e + 000	2.152791e + 000
1.351296e + 000	2.153913e + 000
1.357244e + 000	2.155029e + 000
1.363204e + 000	2.156137e + 000
1.369177e + 000	2.157239e + 000
1.375162e + 000	2.158334e + 000
1.381161e + 000	2.159422e + 000

-continued

1.387171e + 000	2.160503e + 000
1.393195e + 000	2.161577e + 000
1.399232e + 000	2.162644e + 000
1.405281e + 000	2.163704e + 000
1.411343e + 000	2.164756e + 000
1.417418e + 000	2.165802e + 000
1.423506e + 000	2.166840e + 000
1.429607e + 000	2.167871e + 000
1.435720e + 000	2.168895e + 000
1.441845e + 000	2.169911e + 000
1.447984e + 000	2.170920e + 000
1.454136e + 000	2.171921e + 000
1.460361e + 000	2.172915e + 000
1.466478e + 000	2.173901e + 000
1.472669e + 000	2.174880e + 000
1.478872e + 000	2.175851e + 000
1.485088e + 000	2.176815e + 000
1.491317e + 000	2.177770e + 000
1.497559e + 000	2.178718e + 000
1.503814e + 000	2.179658e + 000
1.510081e + 000	2.180591e + 000
1.516362e + 000	2.181515e + 000
1.522656e + 000	2.182431e + 000
1.528962e + 000	2.183340e + 000
1.535282e + 000	2.184240e + 000
1.541615e + 000	2.185132e + 000
1.547960e + 000	2.186016e + 000
1.554318e + 000	2.186892e + 000
1.560689e + 000	2.187759e + 000
1.567073e + 000	2.188618e + 000
1.573470e + 000	2.189469e + 000
1.579881e + 000	2.190311e + 000
1.586304e + 000	2.191145e + 000
1.592740e + 000	2.191971e + 000
1.599190e + 000	2.192788e + 000
1.605652e + 000	2.193596e + 000
1.612126e + 000	2.194396e + 000
1.618614e + 000	2.195186e + 000
1.625116e + 000	2.195969e + 000
1.631630e + 000	2.196742e + 000
1.638157e + 000	2.197507e + 000
1.644698e + 000	2.198263e + 000
1.651251e + 000	2.199009e + 000
1.657818e + 000	2.199747e + 000
1.664397e + 000	2.200476e + 000
1.670989e + 000	2.201195e + 000
1.677594e + 000	2.201906e + 000
1.684213e + 000	2.202607e + 000
1.690844e + 000	2.203299e + 000
1.697489e + 000	2.203981e + 000
1.704146e + 000	2.204654e + 000
1.710817e + 000	2.205318e + 000
1.717501e + 000	2.205972e + 000
1.724197e + 000	2.206617e + 000
1.730906e + 000	2.207252e + 000
1.737629e + 000	2.207878e + 000
1.744364e + 000	2.208493e + 000
1.751113e + 000	2.209099e + 000
1.757874e + 000	2.209695e + 000
1.764649e + 000	2.210281e + 000
1.771437e + 000	2.210858e + 000
1.778237e + 000	2.211424e + 000
1.785051e + 000	2.211981e + 000
1.791878e + 000	2.212527e + 000
1.798717e + 000	2.213063e + 000
1.805570e + 000	2.213589e + 000
1.812436e + 000	2.214105e + 000
1.819314e + 000	2.214610e + 000
1.826206e + 000	2.215105e + 000
1.833111e + 000	2.215590e + 000
1.840028e + 000	2.216064e + 000
1.846959e + 000	2.216528e + 000
1.853902e + 000	2.216981e + 000
1.860858e + 000	2.217423e + 000
1.867827e + 000	2.217855e + 000
1.874810e + 000	2.218276e + 000
1.881805e + 000	2.218686e + 000
1.888813e + 000	2.219085e + 000
1.895834e + 000	2.219473e + 000
1.902868e + 000	2.219850e + 000

25

-continued

1.909915e + 000	2.220217e + 000
1.916974e + 000	2.220572e + 000
1.924047e + 000	2.220916e + 000
1.931133e + 000	2.221249e + 000
1.938231e + 000	2.221570e + 000
1.945342e + 000	2.221881e + 000
1.952466e + 000	2.222179e + 000
1.959603e + 000	2.222467e + 000
1.966753e + 000	2.222742e + 000
1.973915e + 000	2.223006e + 000
1.981089e + 000	2.223258e + 000
1.988277e + 000	2.223499e + 000
1.995478e + 000	2.223728e + 000
2.002691e + 000	2.223945e + 000
2.009917e + 000	2.224150e + 000
2.017156e + 000	2.224343e + 000
2.024407e + 000	2.224524e + 000
2.031672e + 000	2.224693e + 000
2.038948e + 000	2.224850e + 000
2.046237e + 000	2.224995e + 000
2.053539e + 000	2.225127e + 000
2.060854e + 000	2.225247e + 000
2.068181e + 000	2.225355e + 000
2.075521e + 000	2.225451e + 000
2.082873e + 000	2.225533e + 000

26

-continued

	2.090238e + 000	2.225603e + 000
	2.097615e + 000	2.225661e + 000
	2.105005e + 000	2.225705e + 000
5	2.112406e + 000	2.225737e + 000
	2.119821e + 000	2.225756e + 000
	2.127248e + 000	2.225762e + 000
	2.134688e + 000	2.225755e + 000
	2.142139e + 000	2.225735e + 000
10	2.145869e + 000	2.225720e + 000

20. The illumination reflector as recited in claim 19, further being adapted for use in an illumination system, the illumination system having an illumination source, at least one color wheel adapted for receiving light from the illumination source, and a homogenizer lens assembly adapted for receiving light from the color wheel, the reflecting surface of the illumination reflector being computer-generated and being adapted for maximizing reflections of radiation patterns of the illumination source into the color wheel.

* * * * *