

[54] **HEATER REMOTE CONTROL SYSTEM**
 [76] Inventor: **Charles H. Cox, III**, 38 Lakehill Ave., Arlington, Mass. 02174
 [22] Filed: **Sept. 14, 1973**
 [21] Appl. No.: **397,219**

Related U.S. Application Data

[63] Continuation-in-part of Ser. No. 230,378, Feb. 29, 1972, abandoned.
 [52] **U.S. Cl.** **250/199**
 [51] **Int. Cl.²** **H04B 9/00**
 [58] **Field of Search** 250/199; 315/292, 316; 317/124, 127

References Cited

UNITED STATES PATENTS

3,111,587	11/1963	Rocard	250/199
3,289,001	11/1966	Wilcox	250/199
3,652,858	3/1972	Kinsel	250/199
3,670,166	6/1972	Kaminow	250/199
3,676,684	7/1972	DeLange	250/199
3,706,913	12/1972	Malatchi	315/292
3,706,914	12/1972	Van Buren	315/292
3,710,122	1/1973	Burcher et al.	250/199
3,766,431	10/1973	Isaacs	315/292

3,784,875 1/1974 Baker et al. 315/312 X
 3,845,293 10/1974 Borner

Primary Examiner—Robert L. Griffin
Assistant Examiner—Aristotelis M. Psitos
Attorney, Agent, or Firm—Paul & Paul

[57] **ABSTRACT**

A remote control system including infrared transmission means for coupling control signals simultaneously to remotely located instruments from a central station via either a plurality of modulated carriers or digital code words which carry the control information. The remote control system further includes a control coordination means whereby the control of various combinations of instruments can be coordinated. Associated with each instrument is a separator circuit for selecting only the control signal for that instrument, and a controlled device operated upon by such selected control signal and supplying a controlled amount of power to the instrument. By utilizing an infrared transmission means, and placing the controlled device with each instrument, the necessity of installing large numbers of separate, independent circuits is eliminated, and increased flexibility of control is achieved.

11 Claims, 4 Drawing Figures

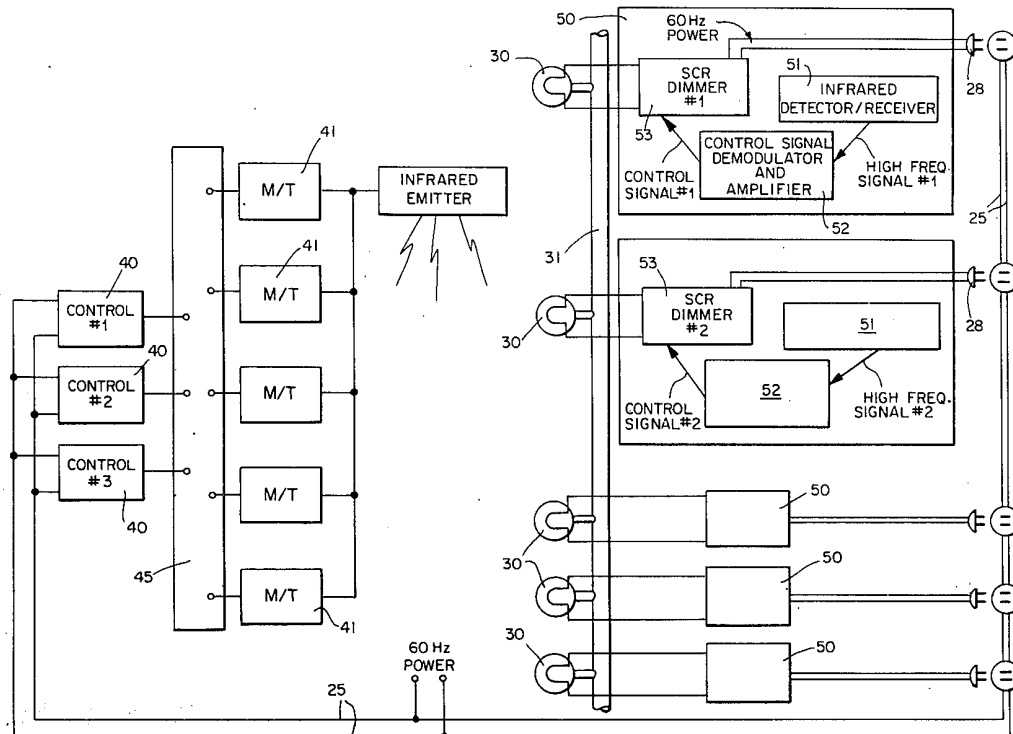

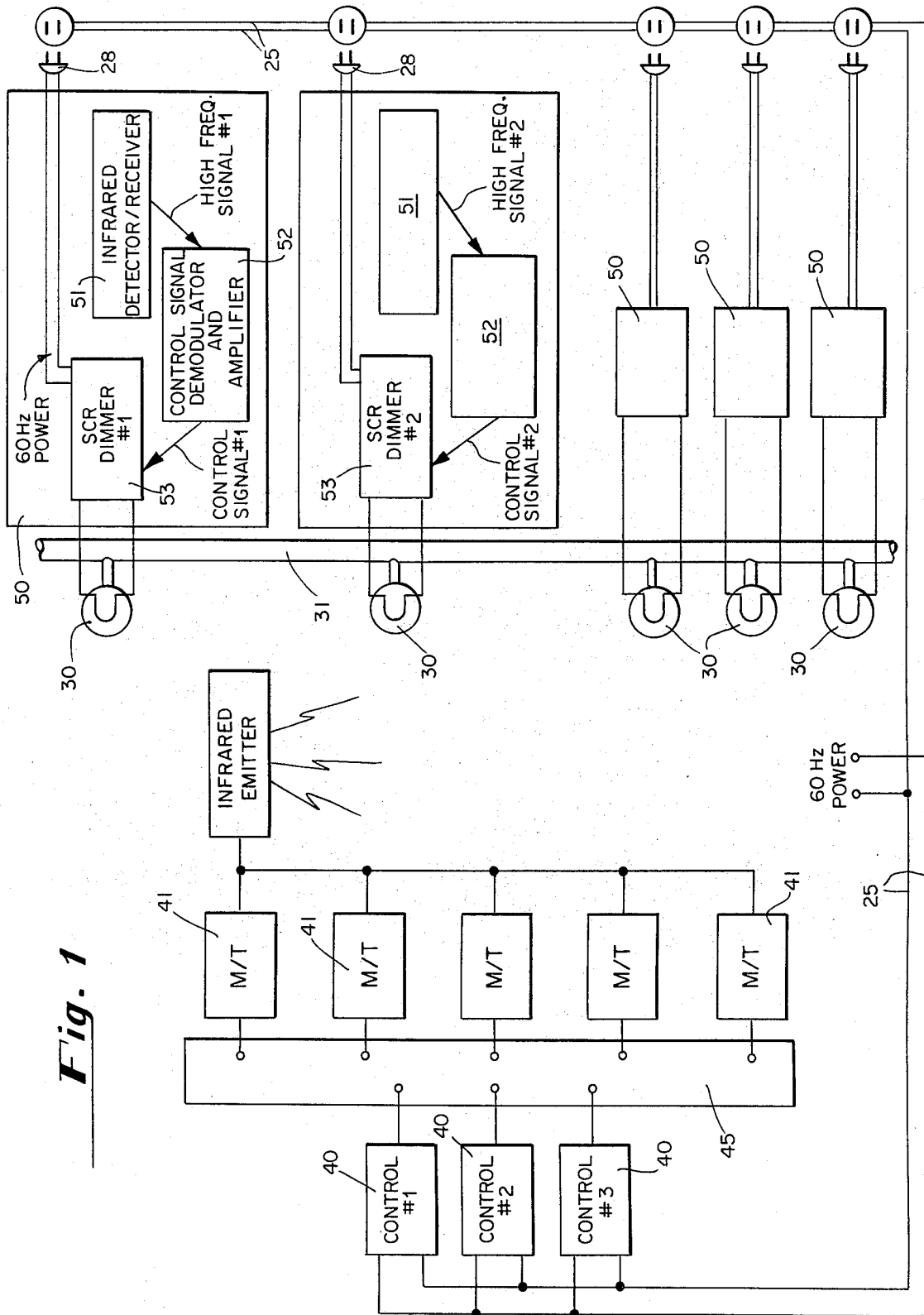

Fig. 1

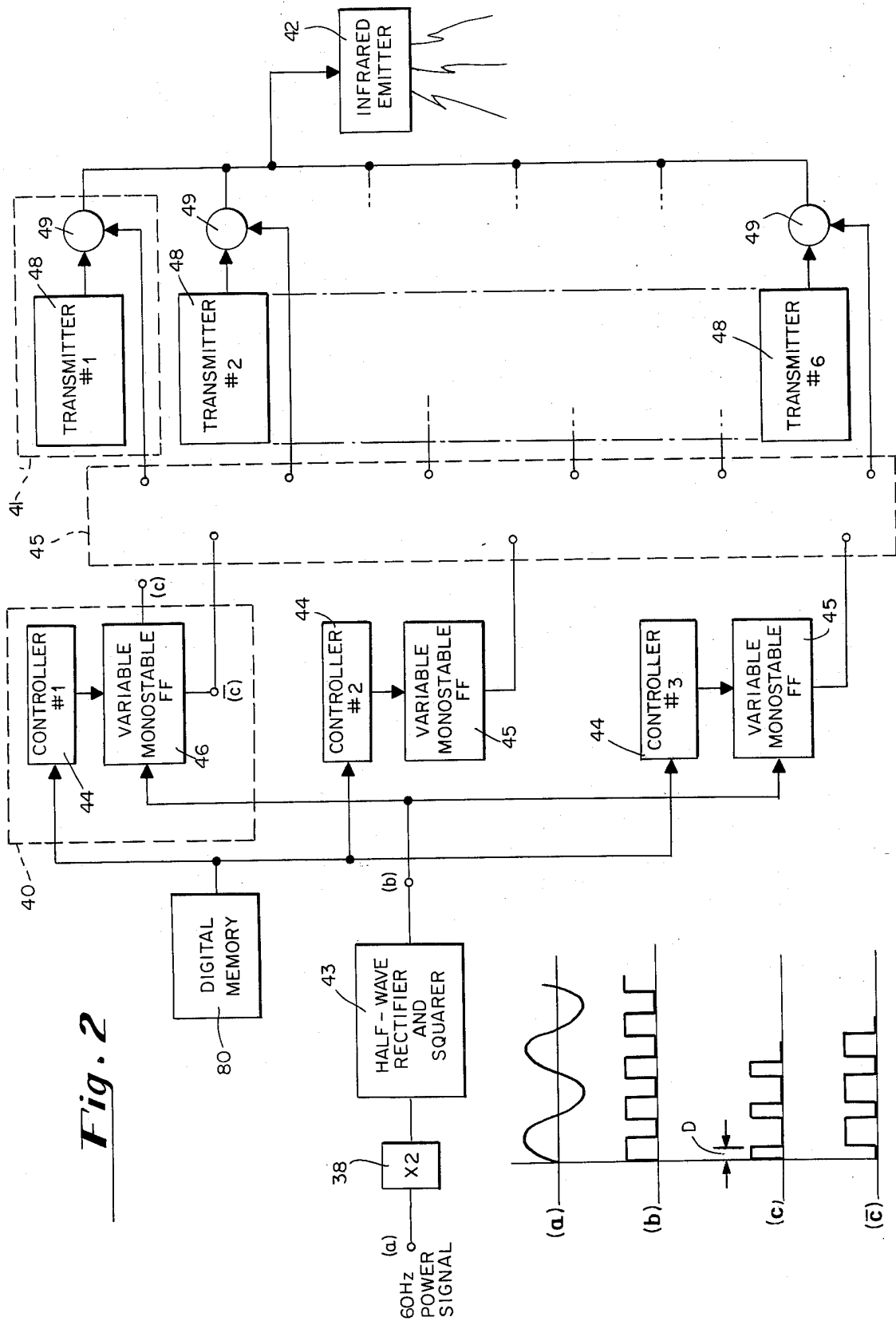

Fig. 2

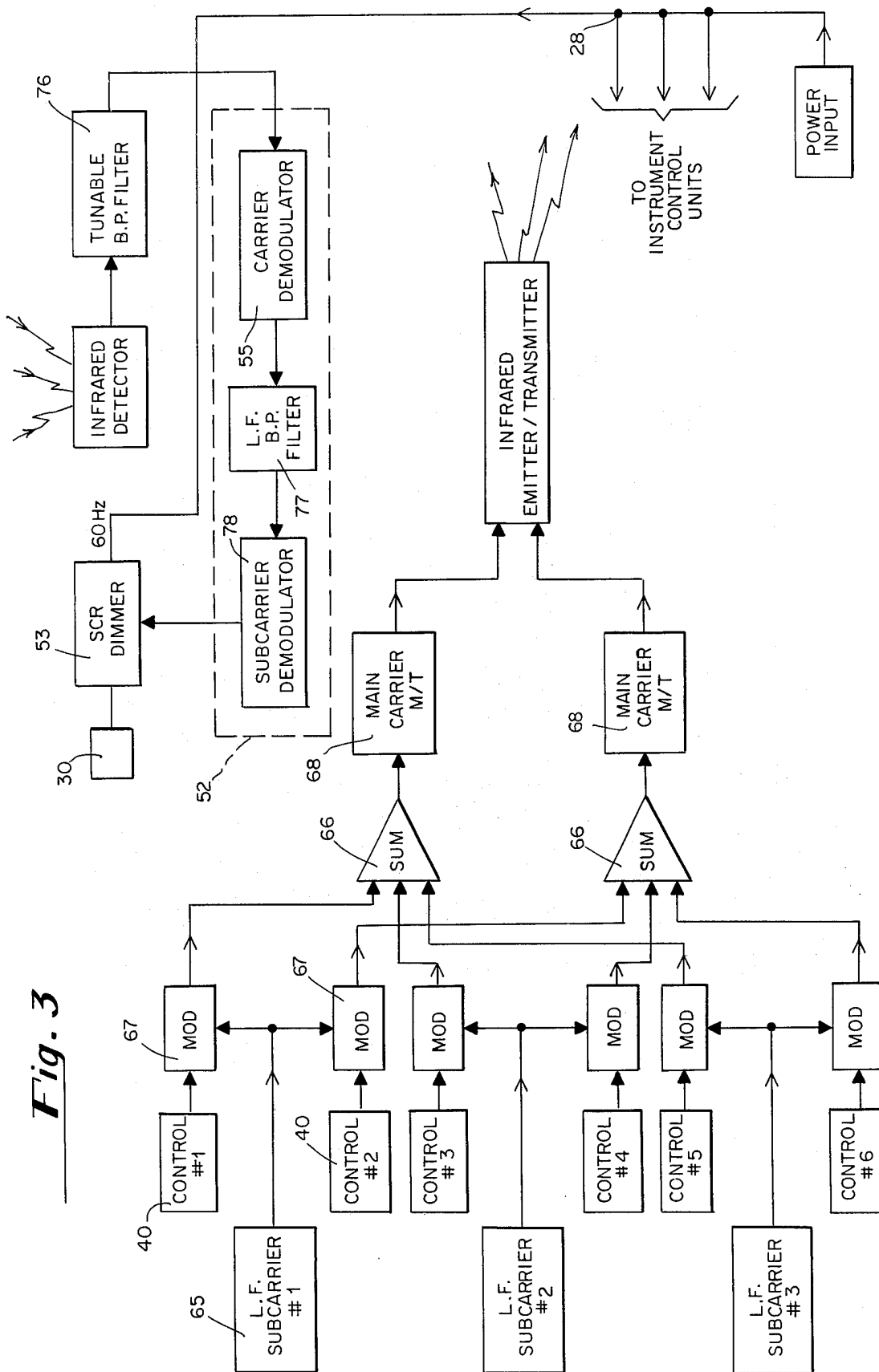

Fig. 3

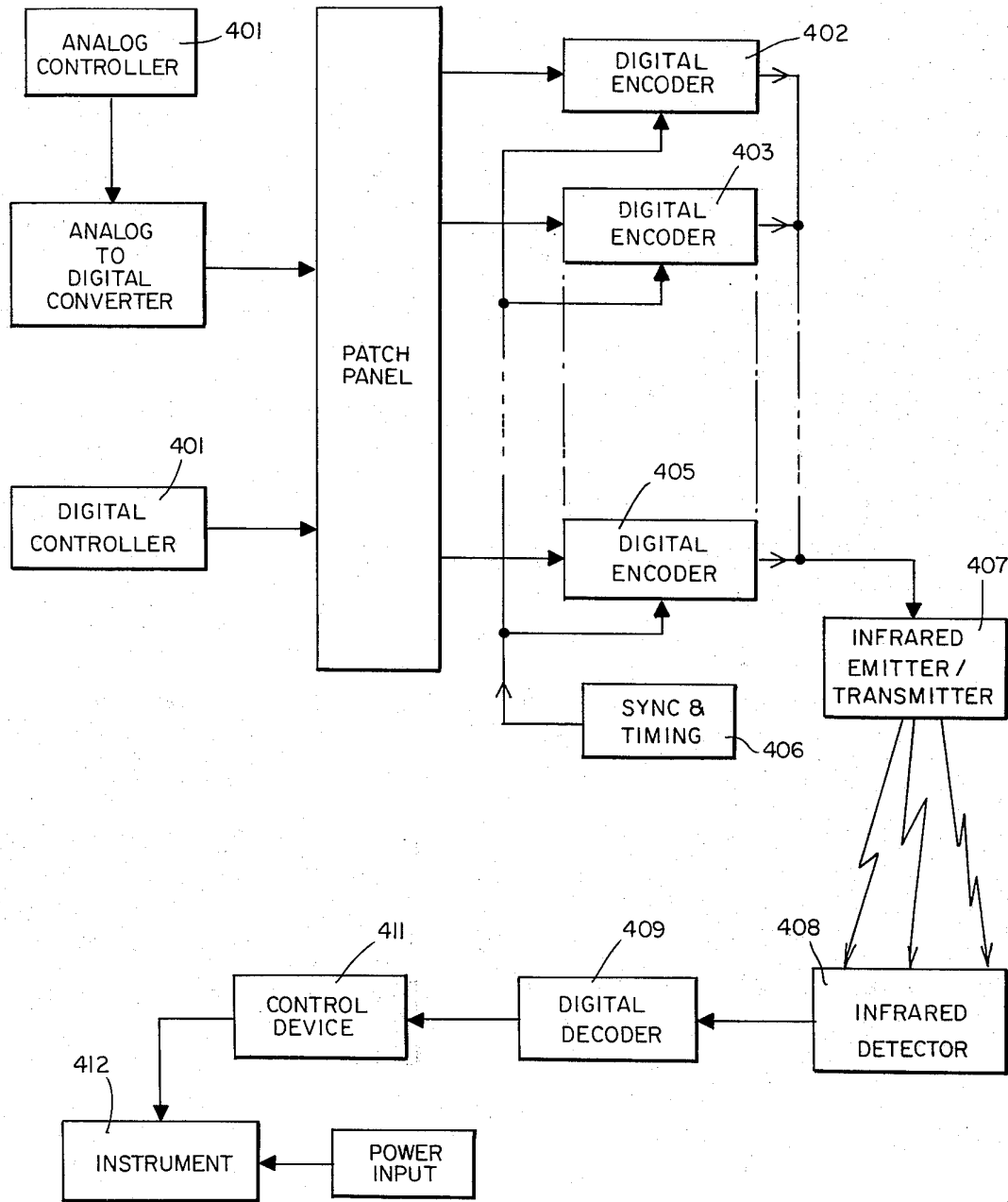

Fig. 4

HEATER REMOTE CONTROL SYSTEM

CROSS-REFERENCE TO RELATED APPLICATION

This is a continuation-in-part of my co-pending U.S. application Ser. No. 230,378 now abandoned, filed Feb. 29, 1972, titled THEATRE LIGHTING CONTROL AND DIMMER SYSTEM.

BACKGROUND OF THE INVENTION

A. Field of the Invention

This invention lies in the field of remote control systems and, more particularly, theatre control systems where all control signals are transmitted together over a common transmission medium and each instrument is controlled by separation of a specific control signal and control of a controlled device at the location of such each instrument.

B. Description of the Prior Art

Theatre lighting, being an integral part of each theatrical performance, or show, requires an implementation with sufficient flexibility to cover the demands of each show produced, and thus any given theatre lighting system must be sufficiently flexible to cover a wide range of different types of shows. A lighting system must provide visibility in different degrees, must provide composition and naturalism, and is essential in providing the overall atmosphere, or mood of the production. Specifically, each instrument used in lighting a given theatrical production has a particular function, e.g., being a solo spotlight, providing a particular effect such as a setting sun, etc. In order to obtain maximum flexibility, each instrument must be subject to separate control, i.e., through its own dimmer. To coordinate intensity changes in a large number of instruments, which instruments are separately located, the standard system has a master control board for control of the dimmers, with a separate circuit from each dimmer to the remote position of the respective instrument.

In the construction of a theatre, it is not conceptually possible to anticipate the maximum number of circuits required at any given location in a theatre for any given show, nor is it economically feasible to install large numbers of circuits which will only be utilized on rare occasions. Consequently, present theatre lighting systems are based on the requirements of an average show, such that large multiconductor cables are installed to the most likely lighting positions. Typically, a total of from 100 to 600 individual circuits are installed, connecting from 50 to 150 dimmers to lighting instruments located throughout the theatre. A patch panel, which is essentially a high powered analog of a telephone switchboard, allows any circuit to be connected to any dimmer. Provisions are also made on the patch panel for more than one circuit, usually between 2 and 6 circuits, to be connected to the same dimmer. Connecting more than one lighting instrument to the same dimmer, however, tends to limit the effectiveness of the instruments, since they cannot be individually programmed.

Unfortunately, few shows are average, such that the specific needs for a given show are rarely met with the installed system. Thus, when more lights are required at a given location than there are circuits leading to such location, the system is inadequate. Two options do exist in such an instance, namely connecting a plurality of instruments together, or temporarily installing extension cords so as to "borrow" or transfer circuits from

other locations to the location where extra circuits are needed. Both of these alternatives result in a serious loss of flexibility, as well as increased installation time and expense.

SUMMARY OF THE INVENTION

It is an object of this invention to provide a remote control system providing optimum flexibility in placement of instruments and control of such instruments, and which is simplified and inexpensive in comparison to prior art remote control systems.

It is further an object of this invention to provide a remote control system wherein control signals for all of the instruments in the system are generated at a remote control location, with all of the control signals being transmitted to respective instruments via infrared light such that separate cables are not necessary, and wherein controlled devices are mounted contiguous to or located near to each instrument and are individually and simultaneously controlled by the transmitted control signals.

It is yet another object to provide a control system for simultaneously operating select ones of a plurality of instruments to any level in their respective operational ranges, i.e., either "on-off" or at any level therebetween, as desired.

Finally, it is another object of this invention to provide means for coordinating the control of many remotely located instruments.

In accordance with the above objects, there is provided a remote control system wherein each of the instruments in the theatre are controlled by a control device positioned contiguous or near thereto, each instrument being connected to a source of power, for example a battery or the theatre system power line with control means positioned at a point remote from said instruments and containing control units for generating control signals for each of such instruments. In one embodiment, the control signals modulate a carrier (or carriers) which are transmitted from such remote position to the respective instruments. In another embodiment, a plurality of subcarriers are generated, each modulated by respective control signals, the subcarriers in turn being combined or multiplexed on a plurality of carriers. In still another embodiment the control signals are transmitted digitally in the form of binary code words.

In a preferred embodiment, infrared transmitters and receivers are utilized. In the environment of a theatre, which has cavernous open spaces, use of infrared transmission allows for application of the principles of the present invention to control speaker systems, self propelled mobile stage props, and the like, as well as to lighting systems and apparatus.

BRIEF DESCRIPTION OF THE DRAWINGS

FIG. 1 is a block diagram of the theatre system of this invention.

FIG. 2 is a block diagram showing the arrangement of the control signal generators and transmitters as used in this invention; curves (a), (b), (c) and (d) in FIG. 2 illustrate the signal waveforms at corresponding points.

FIG. 3 is a modification of FIG. 1, showing an embodiment wherein a plurality of carriers and subcarriers are generated to carry the control signals which are sent to the light instrument dimmers.

FIG. 4 shows an alternative illustrative embodiment utilizing infrared transmission of digital pulses.

DESCRIPTION OF THE PREFERRED EMBODIMENTS

The devices to be controlled are distributed throughout the theatre. There is illustrated in FIG. 1 a plurality of lighting instruments 30, shown connected to a pipe 31 which provides mechanical support of the instruments. The variety of such instruments, and the manner of support of same, are choices available to the user and are, as such, not essential to this system. Hereinafter, the terms "devices" and "instruments" are used interchangeably to describe the apparatus being controlled. Each instrument 30 is electrically connected to the transmission line 25 from a normal electrical plug 28, the connection being made through an instrument control unit 50, the details of which are described hereinbelow.

Remote from the instruments 30, and centrally located to optimum advantage of the operator of the system, are a plurality of control signal generation units 40. Each unit 40 is an electronic system designed to generate a control signal, which control signal is in turn transmitted to at least one lighting instrument, to actuate a control device connected to same. Each control unit 40 produces a distinct control signal, which signals are programmed by the system operator. The outputs of the control units 40 are suitably connected through a patch panel 45 to a plurality of modulator-transmitter (M/T) units 41. Each unit 41 contains a generator for generating a carrier at a specified frequency, and a modulator which receives a control signal from one of the units 40, which control signal is caused to modulate the carrier signal. The outputs of the units 41 are coupled to an infrared emitter which radiates the plurality of modulated carrier signals. The infrared light may be reflected, focused, and/or carried via light pipes as required by a particular installation.

The output from the infrared emitter which is transmitted to all of the infrared detectors/receivers 51 located adjacent to lighting instruments 30, contains a plurality of carriers, each carrying a control signal. In operation, there are as many carriers as there are different control signals to be sent to the control devices associated with each instrument light. Thus, the infrared light detector/receiver at each instrument picks up all of the different carrier signals. These signals are first connected to a control signal separator, unit 51. Unit 51 also contains a tuned band pass filter which separates out one specific modulated carrier signal, which is connected through to the demodulator and amplifier unit 52. Unit 52 recovers the control signal, and connects same to the control input of the controlling device 53. Thus, the control signal is communicated to the controlling device, the power output of which is connected to instrument 30. Thus, for a particular instrument 30, that control signal which is carried by the carrier frequency corresponding to its tuned band pass filter, is detected and caused to control the operation of the instrument, e.g., control the light intensity. Each other instrument has associated with it an instrument control unit 50, containing in its signal separator a band pass filter tuned to a different frequency, so that it can be controlled uniquely of all other instruments in the theatre. Thus, if desired, every instrument 30 can be separately controlled. It is to be noted that, in practice, it may be desired to have a number of separate instruments commonly controlled, in which case the respective carriers for each such instrument carry the same

control signal. This is achieved by proper patching at the control station.

The controlling device 53, as used in the system of this invention, could be an SCR dimmer, the details of which are well known and need not be specified herein. See, for example, the General Electric SCR Manual, Second Edition, pages 119 and 120. In the typical SCR dimmer as presently used in theatres and other applications, the dimming may be manually controlled by varying the time or phase delay which controls the dimming (or portion of each cycle that the power current is passed through the SCR). Alternately, the delay in turn-on time of the SCR, relative to the start of power half cycle, may be controlled by an externally generated control signal. To accomplish this, it is necessary only that the control signal carry information as to when, for each half cycle of the power signal, the SCR is to turn on.

It should be noted that the control units 50, as well as the instruments being controlled, may also be battery powered, for the use of infrared radiation obviates the need for any fixed physical positioning or fixed electrical connection of the instrument being controlled.

By referring now to FIG. 2, a manner of generating the control signals used in this invention may be seen and understood. The 60 Hz power signal, (shown at a), is connected to the input of a frequency doubler 38 which generates a 120 Hz signal. The 120 Hz signal is connected to a halfwave rectifier and squarer 43, the output of which is illustrated at b. The 120 Hz squarewave thus produced is connected to the input of a variable monostable flip-flop 46 within a control unit 40. Flip-flop 46 is set into its temporary state at the start of each positive going portion of the squarewave, i.e., at the start of each cycle of the 120 Hz signal. The flip-flop remains in its temporary state for a length of time determined by the setting of a controller 44, suitably a manually operated potentiometer. Thus, the flip-flop returns to its stable state after a predetermined time period, corresponding to the desired delay before the SCR in the dimmer 53 is to be turned on. The output of flip-flop 46 is shown at c, with the controllable time delay interval shown as D. As is known, the inverse of the c signal, designated as \bar{c} , is also available (or can be generated by passing the c signal through an inverter). Consequently, the \bar{c} output comprises a train of positive pulses, the duration of each positive pulse corresponding to the setting of its controller 44. When, and only when this control signal is received at the SCR dimmer 53, does the SCR therein conduct, such that power current is provided to the instrument light 30 only during the positive portion of the control signal, or after the time delay D. By using a pair of back-to-back SCRs in the dimmer, a controlled power signal is sent to the light instrument 30 each half cycle of the power current.

Other forms of control signals are obviously possible within the scope and spirit of this invention. For example, zero-point or synchronous switching of SCRs is another common triggering technique. As its name implies, zero-point switching turns the SCR on only when the voltage is zero (turn-off is always at a zero), thus avoiding the sharp transient associated with phase or delay switching. Multilevel control is afforded by only triggering the SCR for a fraction of the number of cycles in a fixed interval. For example if the fixed interval is ten cycles of the 60 Hz line frequency, a setting of half on the controller 40 would cause the SCR 53 to

5

conduct on 5 of the 10 cycles; a controller setting of 0.05 would cause the SCR to conduct for only one half cycle over the 10 cycle interval.

When the source of power is DC, some means will have to be provided to turn the SCR off, since with DC, the voltage obviously does not periodically drop to zero. Alternatively, a silicon controlled switch, SCS, which differs from an SCR only in that it also has an off gate, could be used.

All three of the above approaches are well known in the art and hence will not be discussed further here.

The control signals thus generated are connected through patch panel 45, and modulate the output of transmitter 48 by operation of conventional electronic switch 49, or other modulator means. The output of the entire modulator unit 41 is thus a pulse modulated carrier, with an envelope corresponding to the \bar{c} control signal. Each of such pulse modulated carriers, at their respective frequencies, are added together and fed to the infrared emitter. By this arrangement, each SCR dimmer corresponding to a respective lighting instrument 30 receives a corresponding control signal transmitted on that carrier frequency corresponding to the tuned filter associated with that light instrument. In this manner, each light 30 is independently controlled by the setting of a controller 44, such that the system operator can control simultaneously all of the lights from one centralized position.

In a situation requiring a large number of instruments, e.g., 400, to be controlled simultaneously and independently, the use of individual carriers to carry the control information for each instrument is cumbersome. Two alternatives are available — multiplexing and direct digital encoding. Further, two types of multiplexing are well known — frequency multiplexing and time multiplexing. Since these types of multiplexing can be shown from an information theory point of view to be equivalent only the former will be discussed herein.

Referring now to FIG. 3, an alternate embodiment of this invention employing frequency multiplexing is illustrated. In this embodiment, a limited number of main carriers, suitably just two, are utilized. This contrasts with the system as described above, where there are as many carriers as there are light instruments. In this embodiment, each control signal modulates a low frequency subcarrier, the modulated subcarriers in turn being connected to and modulating a transmitter producing a main carrier. Thus, in FIG. 3 there are illustrated two main carrier generators 68, and three subcarrier generators 65. It is to be noted that in a preferred embodiment there are as many different combinations of subcarriers and carriers as there are light instruments, so that the system has capacity to separately control each such instrument. Thus, if there are 64 light instruments to be controlled, and two main carriers, ideally there will be 32 different subcarrier generators 65.

The output of each subcarrier unit 65 is connected to two modulator units 67, each of which modulates in accordance with a separate control signal connected thereto. Thus, from each subcarrier, there are produced two modulated signals. One of each subcarrier is then summed through respective summers 66, the outputs of which are coupled to the main carrier modulator-transmitters (M/T) 68. Thus, each main carrier carries each of the subcarrier frequencies.

6

In this embodiment, the outputs of units 68 are connected to the infrared emitter or transmitter such that both main carriers are transmitted to all of the instrument control units. At each instrument, the control signal is passed through a tunable band pass filter 76, designed to be tunable to one of the two main carrier frequencies available for selection. An advantage is achieved here in that high frequency broad band pass filters are much more economical than the high frequency narrow band pass filters required where each instrument has its own high frequency carrier. The output of filter 76 is coupled to the carrier demodulator 55. There, the carrier is demodulated, the subcarriers are amplified, and one of the subcarriers is selected by a low frequency, (e.g., audio), narrow band pass filter 77. The selected subcarrier is then demodulated by demodulator 78, to derive the control signal which is connected to the controlling device. The power line 25 supplies 60 Hz power current which is connected through to the controlling device.

The advantage of this embodiment of the system lies in the fact that narrow band pass filters at low frequencies are readily available and a large number of subcarriers can be accommodated. For example, there are available commercial filters providing excellent narrow band characteristics at 15 Hz intervals. Thus, 100 to 200 subcarriers could very efficiently be accommodated in this system. By contrast, where each lighting instrument has its own high frequency carrier, it would be necessary to generate such carriers over a wide range of frequencies since it is difficult to obtain narrow band filters at higher frequencies.

Another advantage of this embodiment is that it offers an additional means for controlling various combinations of instruments together. By simply tuning the high frequency bandpass filters to the same frequency, two instruments will receive the same signal and hence operate together. This would be useful in a theatre application for example when it is desired to control the illumination of large areas which require many lighting instruments.

While the above discussion had the high frequency filters tunable and the low frequency filters fixed, obviously the situation could be reversed, making the low frequency filter tunable and the high frequency filter fixed. Further, both could obviously be made tunable.

Another alternate embodiment of this invention employing direct digital modulation will be presented below. See FIG. 4. As previously disclosed, the controller 401 produces a signal which can be connected to various digital encoders 402, 403, 405, etc. The encoders, whose outputs are coordinated by the sync and timing box 406, transform the controller 401 output into a suitable form for transmission. An example of such a transformation would be the addition of redundant information which could be subsequently used by the decoder to reduce the probability of a transmission error. The outputs of all the encoders 402, 403, 405, etc., feed the infrared emitter 407 which radiates or transmits the information. If, for example, a binary code was used in the encoders 402, 403, etc., then the control information is in the form of 0's and 1's with the corresponding infrared emitter 407 output being a sequence of "on" and "off" flashes. At the receiver the infrared radiation is detected at a detector 408, decoded at 409, and fed to the controlling device 411.

The actual information content of the transmitted signal will of course vary considerably depending upon

the application. In the context of controlling lighting instruments, such as 412, several examples of the information transmitted are to be given.

The use of light emitting diode (LED) photo-transistor systems also makes direct digital transmission much more feasible. In such an all-digital system, no carriers or subcarriers are used; instead the information is put in the form of a binary code which in turn is fed directly to the LED, thereby switching it "on" and "off." Whereas in the case of analog modulation, a specific instrument was identified by a certain carrier frequency (or carrier frequency and subcarrier frequency combination), with digital modulation each remote control unit is identified by a binary code word (or some combination of several binary words), as in the following examples.

Example I: Transmit each instrument number, and the corresponding intensity. The transmitter would send each instrument number, followed by the intensity at which that instrument should be set. With a large number of instruments, this is obviously quite a redundant scheme, i.e., with 320 instruments, each of which has control levels, this means that the same intensity will be transmitted 320 times if all instruments are to be at the same intensity.

Example II: Transmit all instrument numbers of same intensity, followed by the desired intensity. This scheme involves transmission of a sequence of instrument numbers followed by a single intensity at which all the previously listed instruments should be set. Thus, this scheme involves division of the transmitted information into frames, each frame including a full set of numbers of instruments to be changed with corresponding intensity changes.

Both of the above schemes still involve considerable redundancy since each instrument must "know" its number, in order to recognize its number when transmitted, such as by means of selective logic means. If the intensities are transmitted in a rigid sequence, i.e., instrument No. 1's intensity is always transmitted first, instrument No. 2's second, etc., then a further simplification can be made. This can be done in at least two ways:

Example III: Transmit intensity, common sync. If a common frequency is available at the transmitter and all receivers, then this frequency can be used to sync the transmitter and receiver. The line frequency is an obvious example.

Example IV: Transmit intensity, self clocking. If some instruments are to be battery operated, for example, then a self clocking code, such as a return to zero code, could be used. In a return to zero code, the level goes to zero between every bit, whereas in conventional binary code the level goes to zero only where the binary zero is to be transmitted. Hence, in a return-to-zero code, the same number of edges get through, independent of the information being sent, and thus these edges can be used to drive or to sync the oscillator at the instrument.

One additional embodiment, which will work under limited conditions, is that the infrared signal can be used directly to control an SCR. Such an embodiment requires a highly directional infrared emitter, such as a laser.

In the foregoing embodiments, it clearly is not necessary for power lines to be connected directly between the transmitter and the receiver. Rather, all that is required is a continuous optical circuit therebetween,

furnished either by open space, mirrors, lenses, fiber-optic bundles, or the like. In most practical situations, the theater affords ample volume for line of sight open space transmission.

Normally, the light-emitting diode (LED) only need be coarsely focused, such as by a 45° beam to on stage instruments and a 180° beam for orchestra and stage footlights. As desired, receiving phototransistors conveniently may be mounted at one end of a black flat finished tube pointing toward the transmitter. Lenses generally are required only for receivers more than 50-100 feet from the transmitter, in accordance with the present state of the art.

The system as thus shown above, in each of the embodiments, is seen to provide great flexibility in allowing the instruments to be connected anywhere in the theatre, and without having to install any connecting cables or circuits. The efficiency of such installations can be improved even further by packaging the instrument control units 50, which include the controlling device, for mounting directly to or on the instrument. By thus integrally connecting the instrument control units to the instruments themselves, there is provided a single package which need only be mechanically supported at the position where it is to be installed. This feature provides optimum installation efficiency, and answers a long and seriously felt need for increased flexibility in theatre lighting systems.

While the preferred embodiments of this invention have been presented in their specifics, it is recognized that variations of specific components of the system may be made within the spirit and scope of the invention.

Even more importantly, the technique of digitally encoding time delay signals makes it possible to directly interface the system with a digital computer, by coding digital words in computer memory to carry the time delay information. For example, a digital memory 80 (FIG. 2) may have stored therein 32 different time delay words, each being a 5 bit word and corresponding to the division of one half the power system period (1/120th second) into 32 fractions thereof. When a given delay is desired (corresponding to a given percentage of full power), the operator may simply read out of the memory the desired word, which is used directly to pulse code modulate a carrier. At the receiving end, a conventional digital-to-analog device is used to generate an appropriate analog control signal which is used to control the SCR dimmer. The technique of read in and read out of a computer, or digital memory, is well known in the art, and need not be amplified further in the specification in order that this be a proper enabling disclosure.

I claim:

1. In a theatre system having a plurality of theatre instruments, an optimal control system for simultaneously operating select ones of said instruments at any level in the operational range thereof while maintaining optimal flexibility in location of said instruments, said control system comprising:

- a. a plurality of instruments located at respective positions in the theatre, each having a different identification code and each including a photosensitive detector, a digital signal decoder, and an actuation control means;
- b. a source of signals, said signals representing specified variations in the operation of select ones of said instruments;

9

c. means for converting said signals from said source to a predetermined digitally coded signal, said code being conditioned to energize actuation control means to bring said instruments selectively to desired operating levels, said means for converting including means for multiplexing signals for a plurality of instruments into an aggregate digital signal of predetermined format to associate control information for a given one of said instruments with the corresponding identification code;

d. optical transmission means including means for translating said aggregate signal into infrared energy, and at least one continuous optical transmission path between said means for translating and each of said photosensitive detectors, whereby transmitted aggregate signals from said optical transmission means contain all actuation control level change information for said theatre, and individual ones of said instruments are conditioned to extract corresponding infrared control signals and to reject infrared control signals which correspond to other ones of said instruments.

2. A system as described in claim 1 wherein said means for converting includes means for producing actuation control level change information in the form of with binary code words uniquely associated with corresponding ones of said instruments, said binary code words representing said identification code, and wherein the digital signal decoder of each said instruments includes logic means energized only by a binary code word associated with the corresponding instruments.

3. A system as described in claim 2 wherein said means for converting includes means for identifying all ones of said instruments having the same prospective actuation control level change, and wherein said multiplexing means includes means for grouping all binary code words of a given prospective actuation control level change with a digitally coded signal of said given prospective actuation control level change.

4. A system as described in claim 2 wherein said multiplexing means includes means for aggregating all binary code words of said instruments followed respectively by coded corresponding prospective actuation control level changes for said instruments.

5. A system as described in claim 1 wherein each of said instruments comprises means for sampling said transmission path at predetermined unique periodic intervals, and wherein said multiplexing means includes timing means for transmitting coded intensity change information only during the intervals during which the corresponding instruments is conditioned to sample said transmission path, the identification of said unique periodic intervals constituting said identification codes.

6. A system as described in claim 1 wherein each of said instruments is connected to said means for translating by a different transmission path, and wherein said means for multiplexing includes means for coupling said means for translating to any given one of said different transmission paths to selectively couple actuation control level change information to a corresponding given one of said instruments, coupling being accomplished on the basis of said different identification codes.

10

7. A system as described in claim 1 wherein said plurality of instruments are lighting instruments, said actuation control level change information being light intensity change information.

8. A system as described in claim 1 wherein each of said instruments is self-clocking, being conditioned to sample said transmission path at intervals derived from the format of the code itself and wherein said multiplexing means includes timing means for transmitting coded intensity change information only during the intervals during which the corresponding instruments is conditioned to sample the said transmission path, the identification of said sampling intervals constituting said identification code.

9. In a theatre system having a plurality of theatre instruments, an optimal control system for simultaneously operating select ones of said instruments at any level in the operational range thereof while maintaining optimal flexibility in location of said instruments, said control system comprising:

a. a plurality of instruments located at respective positions in the theatre, each being associated with a photosensitive detector, a carrier demodulator, and an actuation control means;

b. a source of signals representing specified variations in the operation of select ones of said instruments;

c. transmitter means, comprising a plurality of high frequency carrier generators, each generating a respective different carrier and each being modulated to carry information of the control signal of one of said control units;

d. infrared transmission means, comprising a non-coherent infrared signal emitter and an optical transmission path to all of said instruments, for providing continuous signal transmission from the location of said transmitter means to the location of said light instruments;

e. a plurality of infrared detectors located respectively at the locations of said light instruments; and

f. control signal separation means, connected to respective ones of said detectors, for separating at each said instrument a given one of said transmitter carriers, deriving the control signal carried thereon, and coupling said control signal to the controlled device positioned with said instruments.

10. A system as described in claim 9, wherein:

a. said transmitter means comprises a plurality of low frequency subcarrier generators, signals from each such subcarrier generator being modulated by respective said control signals, the modulated subcarriers being multiplexed onto signals at said carrier transmitters so that said carriers are modulated to carry said modulated subcarriers; and

b. said separation means has a tunable high frequency band pass filter to separate out one of said carriers, and a low frequency band pass filter to separate out a specific one of said subcarriers.

11. A system as described in claim 9 wherein said plurality of instruments are lighting instruments, said actuation control level change information being light intensity change information.

* * * * *

UNITED STATES PATENT OFFICE
CERTIFICATE OF CORRECTION

Patent No. 3,924,120 Dated December 2, 1975

Inventor(s) Charles H. Cox, III.

It is certified that error appears in the above-identified patent and that said Letters Patent are hereby corrected as shown below:

In the title of the patent, column [54] "HEATER REMOTE CONTROL SYSTEM" should read --THEATER REMOTE CONTROL SYSTEM--.

Column 1, in the title, "HEATER REMOTE CONTROL SYSTEM" should read --THEATER REMOTE CONTROL SYSTEM--.

Column 3, line 21, "unti" should read --unit--.

Signed and Sealed this

Sixteenth Day of November 1976

[SEAL]

Attest:

RUTH C. MASON
Attesting Officer

C. MARSHALL DANN
Commissioner of Patents and Trademarks