

Aug. 14, 1962

S. J. SKIRPAN

3,049,645

PRESET LIGHTING CONTROL SYSTEM

Filed June 29, 1959

2 Sheets-Sheet 1

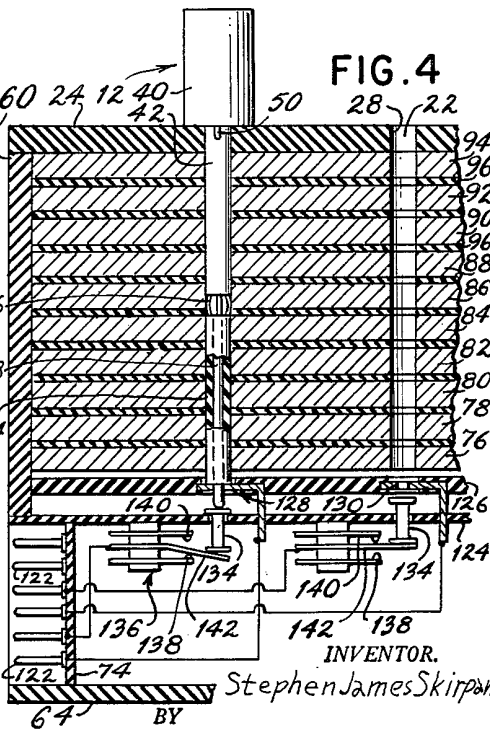
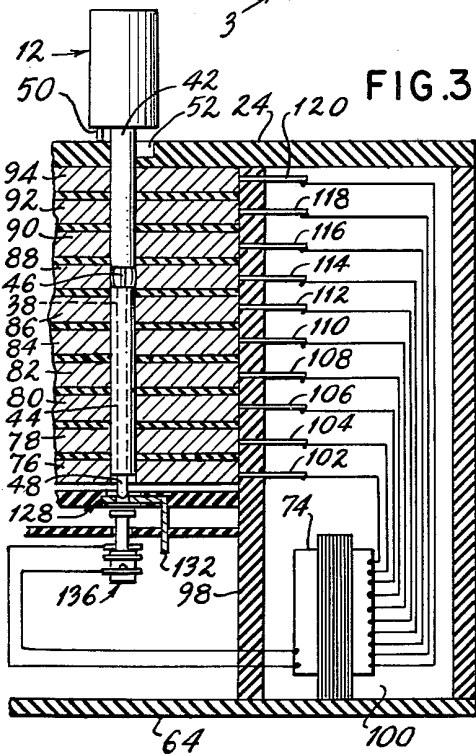
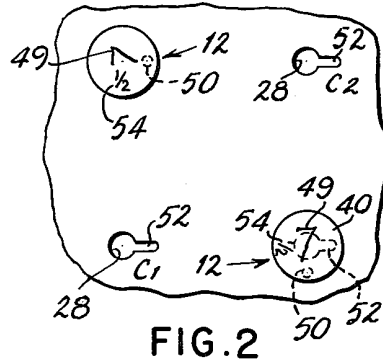
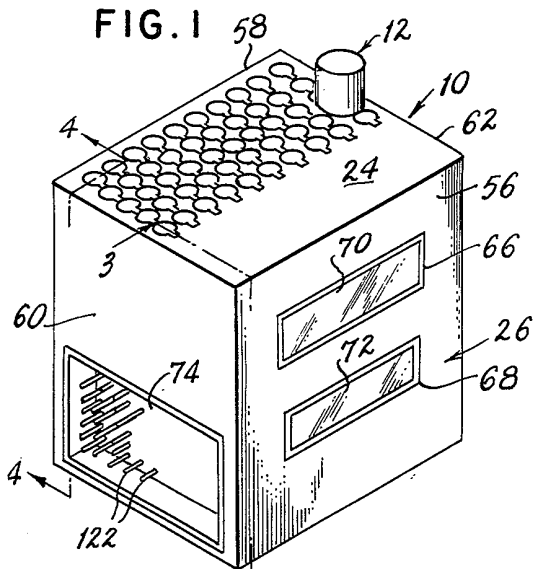

INVENTOR.  
 Stephen James Skirpan  
 BY  
*W. J. Melfano*  
 ATTORNEY

Aug. 14, 1962

S. J. SKIRPAN

3,049,645

PRESET LIGHTING CONTROL SYSTEM

Filed June 29, 1959

2 Sheets-Sheet 2

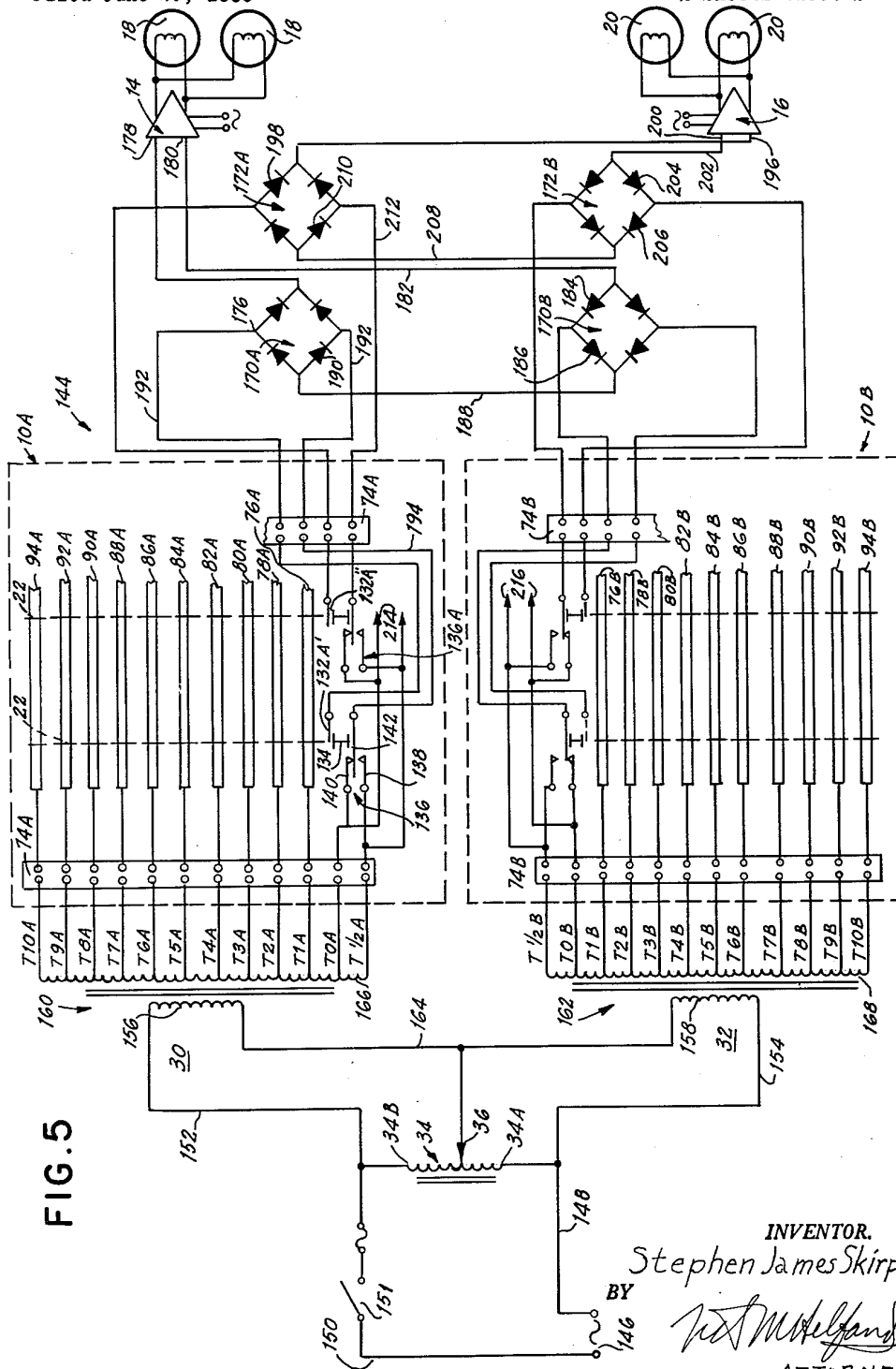

FIG. 5

INVENTOR.  
Stephen James Skirpan  
BY  
*W. M. Helgand*  
ATTORNEY

1

3,049,645

**PRESET LIGHTING CONTROL SYSTEM**

Stephen James Skirpan, New York, N.Y.

(34—15 Parsons Blvd., Flushing, N.Y.)

Filed June 29, 1959, Ser. No. 823,632

15 Claims. (Cl. 315—316)

The present invention relates, in general, to a lighting control system and, in particular, to such a system primarily intended for use in the control of lighting for theatrical stages, television studios and the like.

The prior art utilized a number of different systems in attempting to provide a satisfactory lighting control system. An early system utilized banks of large variable resistors connected in series with incandescent lamps for the purpose of controlling the intensity of said lamps. In addition to other disadvantages, there was the important disadvantage in this system in that only two circuits could be effectively controlled by a single operator in a change involving numerous circuits traveling to various intensities simultaneously.

The variable resistor was replaced by the variable auto-transformer. However, it was still impossible for a single operator to control more than a few circuits in a complex proportional change.

Recently there have been used thyatron, magnetic, and semi-conductor power amplifier systems which control the effective current to the lamp loads and thereby their intensity. The power gain of these systems permits many kilowatts of lamp load to be controlled by a few watts of signal power. These systems utilize a crude and limited memory storage, known in the art as "presetting," by which signal potentiometers are duplicated for storage purposes. However, such a system is extremely limited in storage capacity and therefore requires the resetting of thousands of potentiometers during a typical one-hour television presentation; presents problems of parallax; and is not adapted to present light variables, such as color or focus.

A great improvement over the prior art systems is disclosed in my pending application Serial No. 666,004, filed June 17, 1957, now Patent No. 2,994,804 granted August 1, 1961, which utilizes a card system and is particularly applicable to large television studios.

In view of the foregoing, it is an object of the present invention to provide a lighting control system which obviates the disadvantages of the prior art systems.

Another object of the present invention is to provide a lighting control system which is capable of substantially unlimited storage or presetting.

Another object of the present invention is to provide a lighting control system which can be used to activate any suitable power amplifier for the purpose of controlling the intensity of lamps or for the control of any suitable servomechanism for controlling the other variables of light, such as color, focus, spread, matting, load switching or position.

Another object of the present invention is to provide a control console which fulfills the foregoing objects and is small and compact in construction and simple in operation.

Another object of the present invention is to provide a lighting control system having provision for substantially limitless memory storage and capable of the "readout" or functional translation of preview and active storage group or presets.

Another object of the invention is to provide a lighting control system having infinite memory storage capacity and capable of fast "read-in" or establishment of the memory data for each desired lighting arrangement.

Still another object of the invention is to provide a

2

lighting control console with substantially limitless memory storage capability, which utilizes definite quantities for storage and does not suffer from the problems of parallax in the method of storage or the danger of inaccuracies due to jarring, jolting or similar disturbances.

A further object of the invention is to provide a lighting control system with substantially limitless memory storage capacity and capable of fast changes in the programming of storage groups or presets or in the "bit" information within the presets.

A still further object of the invention is to provide a lighting control system capable of the previously mentioned advantages but nevertheless extremely inexpensive in manufacture, installation and maintenance, and therefore practical for use in small theatres and schools.

The foregoing and other objects and advantages of the lighting control system of the present invention will become more readily apparent to those skilled in the art from the embodiment thereof more or less diagrammatically shown in the accompanying drawing and from the related description following. It is to be understood, however, that such embodiment is shown by way of illustration only, to make the principles and practice of the invention more readily comprehensible, and without any intent of limiting the invention to the specific details therein shown.

In the drawings:

FIG. 1 is a perspective view of a preset block assembly or lighting control console pursuant to the present invention;

FIG. 2 is a fragmentary top plan view of FIG. 1 on an enlarged scale;

FIG. 3 is a sectional view taken on line 3—3 of FIG. 1, and illustrates a control plug inserted in the preset assembly with the plug in a raised or retracted position;

FIG. 4 is a sectional view taken on line 4—4 of FIG. 1, and illustrates a control plug inserted in the preset assembly in a lowered or fully inserted position for contact with a different bus; and

FIG. 5 is a schematic wiring diagram of the lighting control system of the invention.

Briefly described, the present invention utilizes preset block assemblies or control console 10 (FIG. 1) to receive plug assemblies 12 (FIGS. 3 and 4) provided with control information to control the intensity or other variables of a lighting system through the operation of conventional power amplifiers 14, 16 (FIG. 5) and conventional transducers 18 and 20.

The preset block 10 has a number of plug channels or jacks 22 (FIGS. 2 and 4). Each of these plug channels represents a dimmer control circuit which may be identified in any suitable manner. The top plate or wall 24 of the casing or housing 26 is provided with an entrance aperture 28 for each channel or jack 22. Each aperture 28 may be suitably marked to identify each dimmer control circuit and its jack or channel 22. For example, and not by way of limitation, the indicia  $C_1$  and  $C_2$  are shown inscribed in cover plate 24 to identify the two lighting control circuits associated with channels terminating in the free entrance apertures 28 shown therein. By the insertion of plug assemblies 12, which transmits control information into the various plug channels 22, each dimmer circuit can be set to a desired output. Each preset block or console would then represent a scene or preset.

Each preset block has provision to control a plurality of lighting circuits and to provide any one of a plurality of different intensity possibilities for the light source associated with each circuit, depending upon the construction of the control plug 12 which is inserted in the associated channel 22. Any number of preset blocks 10 may be set up for a given production or play.

Two input channels 30 and 32 (FIG. 5) are provided in the system for the supply of current to the preset blocks 10A and B. A fader 34 is utilized to change the input channels. Depending upon the position of the fader control 36, the channels are alternately energized. The arrangement is such that the preset blocks may be successively inserted into the input channels, one of which is in operative condition while the other is in inoperative or stand-by condition; provision being made to alternate the control of the system from one channel to the other channel as successive lighting effects are required. Although the control information is digitally stored in each preset block, the fader circuit is so arranged that an analog transition is effected when progressing from one input channel to the next. Any number of lighting circuits can be controlled to any number of preset arrangements by the operation of one control, the fader, and the insertion of preset blocks into alternate input channels.

Referring now to the drawings in detail, the control plug assembly 12 is best illustrated, in two different representations, in FIGS. 3 and 4. As there shown, the plug assembly comprises an electrically conductive shaft 38 formed of any suitable conductive material, preferably brass. The shaft 38 is threaded into a head or finger piece 40 formed of a suitable dielectric material, such as Bakelite. The shaft is encompassed with an upper dielectric sheath or sleeve 42 and with a lower dielectric sheath or sleeve 44. The sheaths completely enclose the shaft and electrically insulate the latter except for (1) a four-leaved, Phosphor bronze spring contact 46 provided on the shaft and interposed between the sleeves 42, 44 to space the latter and (2) an elongated, reduced-diameter output contact terminal or tip 48 projecting from the inserted end of the shaft 38 and extending beyond the lower sleeve 44. It will be readily apparent that the spring 46 and the contact tip 48 are electrically connected together by shaft 38.

Pursuant to the present invention, the distance or spacing between the spring 46 and the terminal contact tip 48 determines the light controlling intensity value of any particular plug assembly and any suitable, arbitrary designations may be utilized to indicate this control intensity designation. For example, as best shown in FIG. 2, the heads 40 of the plug assemblies may carry a numerical whole number indicia 49 to indicate the control intensity of the particular plug. As here shown, each plug head is provided also on its lower surface with a depending pin 50, formed of a suitable durable metal, such as steel. Each channel aperture 28 is provided with keyway or slot 52 to accommodate pin 50 for a purpose hereafter explained in detail. As here shown, the slot 52 extends ninety degrees to the right, at the three o'clock position relative to the front of the casing. In addition to the whole number indicia 49, each plug head is inscribed also with the designation "1/2," as indicated by the reference numeral 54. The indicia 54 is inscribed at right angles to the primary indicia 49 and is located clockwise of the associated pin 50, viewed as in FIG. 2.

In the illustrated embodiment of the invention, the block assembly 10 is provided with fifty plug channels or jacks 22, each of which bears a suitable identification indicia on the upper dielectric plate 24 of the casing 26. Only one plug 12 for connection to a lighting control circuit is provided and as shown is inserted in one of the jacks 22. The casing 26 also comprises front and rear walls 56 and 58, side walls 60 and 62 and bottom wall 64, all formed of suitable dielectric material or provided with suitable electric insulation on their inner faces. The front wall 56 is provided with two frames or holders 66 and 68 into which there may be readily inserted identification tabs 70 and 72 to identify, respectively, the production and the particular preset, so as to clearly identify the control information set up on the control assembly or block 10. The side wall 60 mounts a male prong connec-

tion socket 74 to connect the control block 10 into either input channel 30 or 32 (FIG. 5).

As best shown in FIGS. 3 and 4, each preset block or control console 10 is provided with ten horizontally stacked voltage busses or plates 76, 78, 80, 82, 84, 86, 88, 90, 92 and 94, preferably formed of aluminum, which are separated by dielectric plates 96. The voltage and dielectric plates are all apertured in register with one another to provide the channels or jacks 22, which, in the illustrated embodiment, number fifty. The voltage busses or plates are insulated from the casing by the dielectric material from which the latter may be formed or by insulation which may be interposed. An interior dielectric wall 98, within the casing and spaced from front wall 56, defines therewithin a wiring channel 100. The voltage busses are provided with terminal connections 102, 104, 106, 108, 110, 112, 114, 116, 118 and 120, respectively, mounted by wall 98 and extending into the channel 100 for connection to the respective prongs 122 of the male connection 74.

In addition to the inner vertical wall 98, the console 10 is provided with a pair of vertically spaced, horizontally disposed, superposed dielectric walls 124 and 126 with wall 126 being immediately below the voltage plate 76. Each channel 22 is provided at the bottom thereof with an output terminal jack 128 mounted on insulating wall 126. Each terminal jack 128 is apertured, as at 130, in registry with the associated channel 22, and is provided with a terminal connection 132 projecting through the dielectric member 124 and electrically wired to an associated prong 122. In registry with each aperture 130, the member 124 slideably supports a dielectric plunger 134 preferably formed of nylon. Wall 124 supports a switch 136 for each channel 22. Switch 136 is provided with a pair of spaced fixed contacts 138 and 140 and with an intermediate movable spring contact 142 normally engaging contact 140 and supporting the plunger 134 and normally biasing the latter to an upper position thereof, all as shown at the right viewing FIG. 4.

When a plug assembly 12 is inserted into a channel or jack 22, it will connect an output jack terminal 132 to a particular voltage bus, depending upon the "value" of the plug assembly. As previously indicated, the "value" depends upon the spacing of the spring contact 46 from the terminal tip 48 of the plug assembly. For example, as shown in FIG. 3, there is illustrated a jack assembly 12 which has its spring contact 46 so disposed vertically of its shaft 38 that, in the illustrated position, it will electrically engage voltage bus 88 to electrically connect the latter to output terminal 132. Consequently, it will be readily apparent that by providing various plug assemblies, each having its spring contact differently positioned thereon, it is possible to selectively connect any voltage bus to an output terminal 132. With each bus having a different voltage level, any one of ten voltage values may be provided upon the selection of the appropriate plug 12. The proper selection of a desired value is facilitated by the utilization of a different indicia 49 for each of the ten values or voltage steps. In all cases the plug is releasably retained in its inserted position by the spring contact 46.

It will be noted that in the condition shown in FIG. 3, the pin 50 is not inserted into the keyway 52, so that the plug is in the raised condition. This condition is illustrated in the right-hand corner viewing FIG. 2, and it will be noted that, as viewed by an operator, the main indicia value 49 for the plug assembly is shown upright, so that the operator knows that the plug is inserted to provide one of ten primary voltage increments or steps.

Pursuant to a highly novel aspect of the present invention, the ten basic voltage steps may be increased to twenty voltage increments without adding any additional voltage plates or busses. This feature is illustrated in FIG. 4. By rotating the plug assembly in a counter-clockwise direction from the position shown in the lower

5

right-hand corner of FIG. 2 to that shown in the upper left-hand corner of the figure, the pin 50 may be inserted into the keyway 52 so as to move the plug assembly down from its raised position shown in FIG. 3 to its lowered position shown in FIG. 4. In the raised position the contact pin, while electrically engaging in aperture 130 of terminal 128, is spaced from plunger 134. However, in the lowered position the contact pin, in addition to making electrical contact with aperture 130, engages and depresses plunger 134 so as to move spring element 142 out of engagement with contact 140 and into engagement with contact 138. As hereinafter described in greater detail, the voltage output or intensity value will now be proportionate to the value associated with the primary indicia 49 plus one-half of a full or primary voltage step or increment between voltage values. In the last described position of the plug assembly, the indicia 54 is upright for ready notice by the operator, as shown in the upper left-hand corner of FIG. 2. In this manner, twenty intensity steps or increments, ranging in increments of one half of step 1 through step 10½, may be provided without substantially increasing dimensions, complexity, or cost, or necessitating the stocking of special plugs of other values.

Referring now to FIG. 5 in detail, the lighting control system, generally indicated by reference numeral 144, is energized from a suitable alternating current supply 146 to which the fader 34 is connected by leads 148 and 150; the latter including a master switch 151. Fader 34 comprises a variable autotransformer which is connected by leads 152 and 154, respectively, to one end of the primary windings 156 and 158 of transformers 160 and 162, respectively. The other ends of the primaries are interconnected by lead 164 to which is connected the variable control arm 36 of the fader 34. Movement of control arm 36 in either direction progressively energizes one primary winding while progressively deenergizing the other primary winding. As here shown, each transformer secondary 166 and 168 has twelve taps. The taps T-1A through T-10A of secondary winding 166 provide ten equal voltage increments above tap T-0A, and tap T-½A provides one half of the voltage increment provided between the other taps. Similarly, taps T-1B through T-10B of secondary winding 168 provide ten equal voltage increments above tap T-0B, and tap T-½B provides one half of the voltage increment provided between the other taps. Taps T-0A and T-0B, provide common return paths for their associated secondaries when the associated switches 136 are normally closed at their contacts 140, 142, taps T-½A and T-½B constituting the common returns for their associated secondaries when the associated switches 136 are closed at their contacts 138, 142. A first preset block or control assembly is indicated at 10A and a second preset block or control assembly is indicated at 10B.

The voltage taps of secondary 166 are electrically connected to the prongs of male connector 74A of assembly 10A and the voltage taps of secondary 168 are electrically connected to the prongs of male connector 74B of assembly 10B. Consequently, the assembly 10A is plugged into input channel 30 and is fully energized when the control arm 36 of fader 34 is at 34A. Similarly, assembly 10B is plugged into input channel 32 and is fully energized when control arm 36 is at 34B.

Only two power amplifiers 14 and 16 and their related circuits are shown in FIG. 5, each feeding the associated transducers 18 and 20. Each dimmer or light control circuit has a pair of silicon rectifier bridges. As here shown, one jack output terminal 132A' is connected through plug 74A to the input end of bridge 170A and another output terminal 132A'' is connected through plug 74A to the input end of bridge 172A. With output terminal 132A' engaged by the tip of a plug assembly 12 which is in retracted position as shown in FIG. 3,

6

voltage bus 88A is connected to the terminal to provide the voltage at seven full increments to the input terminal 176 of bridge 170A. The seven increment voltage is applied as a signal or control voltage to the positive input terminal 178 of power amplifier 14. The return circuit may be traced from the negative terminal 180 of the power amplifier 14 through lead 182, through rectifiers 184 and 186 of bridge 170B, through lead 188 to bridge 170A and through rectifier 190 of the latter, through lead 192, plug 74A, lead 194, switch contacts 142, 140 to tap T-0A. Consequently, it will be apparent that the voltage between taps T-0A and T-7A is applied to the amplifier 14. Similarly, when output terminal 132A'' is contacted by a plug tip, a signal or control voltage is applied to the positive terminal 196 of amplifier 16 through rectifier 198 of bridge 172A, the return from the negative terminal 200 of amplifier 16 being through lead 202, rectifiers 204 and 206 of bridge 172B, through lead 208, rectifier 210 of bridge 172A, lead 212, connector 74A, and normally closed switch 136A. It will be apparent that by selecting the particular voltage bus which is to be engaged by a plug 12, the corresponding voltage may be applied to the power amplifiers.

When the plug is in its lower position, as in FIG. 4, the return circuit from the energized amplifier is not to tap T-0A or T-0B, as the case may be, but is effected through the now engaged contacts 138, 142 of the associated switch 136, to the lowermost tap T-½A or T-½B, as the case may be, as will be readily apparent. This provides a voltage increment equal to one half the basic voltage increment, which is added to the latter, in accordance with the value of the particular plug 12 being used. In this way, an additional voltage of one half an increment can be provided for each voltage bus. For example, assuming that the voltage increments are 10 volts each, with bus 76A representing 10 volts, plug 12 shown in FIG. 3 would represent 70 volts. However, in FIG. 4, plug 12, as inserted, would provide 60 volts for bus 86 plus the additional 5 volts for the additional tap T-½A for a total of 65 volts. In this manner, it is possible to provide 20 voltage increments, instead of the 10 voltage increments provided directly by the busses.

It will be apparent that control channel 32 operates in the same manner as control channel 30, as described above, and that when one channel is deenergized its control assembly may be removed and replaced by another control assembly 10. The arrowheads 214 and 216 indicate that additional power amplifier circuits may be connected to each control assembly or console.

This completes the description of the lighting control system of the present invention, its mechanism and manner of operation. It will be readily apparent that numerous modifications and variations thereof may be made by any one skilled in the art, in accordance with the principles of the invention hereinabove set forth and without the exercise of any inventive ingenuity. I desire, therefore, to be protected for any and all such modifications and variations that may be made within the spirit of the invention and the scope of the claims hereto appended.

What I claim is:

1. A control assembly for a lighting system, comprising a plurality of voltage busses mounted in stacked relation, said busses being mutually insulated, means defining a plurality of channels extending laterally through said busses, each channel having an inlet opening and an outlet opening at the opposite end from said inlet opening, a terminal means at each outlet opening spaced from said stacked busses, and control plug means insertable in said channels through said inlet openings to extend out through said outlet opening to electrically connect a predetermined bus with the terminal means of the channel in which the plug is inserted.

2. A control assembly for a lighting system, compris-

ing a plurality of voltage busses mounted in stacked relation and extending in parallel planes, said busses being mutually insulated, means defining a plurality of channels extending laterally through said busses and intersecting each bus, each channel having an inlet opening and an outlet opening, a terminal means at each outlet opening spaced from said stacked busses, and control plug means insertable in said channels through said inlet openings and having provision to electrically connect a predetermined bus with the terminal means of the channel in which the plug is inserted, said busses being in parallel stacked relation, said control plug means constituting an elongated member which is completely insulated except for a tip engageable with said terminal means and a contact in circuit with said tip and spaced above the latter.

3. A control assembly for a lighting system, comprising a plurality of voltage busses mounted in stacked relation and extending in parallel planes, said busses being mutually insulated, means defining a plurality of channels extending laterally through said busses and intersecting each bus, each channel having an inlet opening and an outlet opening, a terminal means at each outlet opening spaced from said stacked busses, and control plug means insertable in said channels through said inlet openings and having provision to electrically connect a predetermined bus with the terminal means of the channel in which the plug is inserted, said busses being in parallel stacked relation, said control plug means constituting an elongated member which is completely insulated except for a tip engageable with said terminal means and a contact in circuit with said tip and spaced above the latter, said contact having provision to effect resilient engagement with a predetermined bus.

4. A control assembly for a lighting system, comprising a plurality of voltage busses mounted in stacked relation and extending in parallel planes, said busses being mutually insulated, means defining a plurality of channels extending laterally through said busses and intersecting each bus, each channel having an inlet opening and an outlet opening, a terminal means at each outlet opening spaced from said stacked busses, and control plug means insertable in said channels through said inlet openings and having provision to electrically connect a predetermined bus with the terminal means of the channel in which the plug is inserted, said busses being in parallel stacked relation, said control plug means constituting an elongated member which is completely insulated except for a tip engageable with said terminal means and a contact in circuit with said tip and spaced above the latter, and means operable by said tip to increase the voltage at said terminal means.

5. A lighting control system comprising fader means, a first and a second control channel energized by said fader means, a control console connected in circuit in each control channel, each console comprising a plurality of voltage busses mounted in stacked relation, said busses being mutually insulated, means defining a plurality of channels extending through said busses, each channel having an inlet opening and an outlet opening, a terminal means at each outlet opening spaced from said stacked busses, and control plug means insertable in said channels through said inlet openings and having conductive means to electrically connect a predetermined bus with the terminal means of the channel in which the plug is inserted, each control channel having means to apply stepped voltage values to the respective busses of the associated console, and means in circuit with each terminal means to energize a lighting circuit in accordance with the voltage applied to the associated terminal means.

6. A lighting control system comprising fader means, a first and a second control channel energized by said fader means, a control console connected in circuit in each control channel, each console comprising a plurality of voltage busses mounted in stacked relation, said busses being

mutually insulated, means defining a plurality of channels extending through said busses, each channel having an inlet opening and an outlet opening, a terminal means at each outlet opening spaced from said stacked busses, and control plug means insertable in said channels through said inlet openings and having conductive means to electrically connect a predetermined bus with the terminal means of the channel in which the plug is inserted, each control channel having means to apply stepped voltage values to the respective busses of the associated console, and means in circuit with each terminal means to energize a lighting circuit in accordance with the voltage applied to the associated terminal means, said means to apply stepped voltage values being a stepped transformer secondary having equally spaced taps connected to said busses, respectively, and a common tap on a return circuit with the associated lighting circuit energizing means.

7. A lighting control system comprising fader means, a first and a second control channel energized by said fader means, a control console connected in circuit in each control channel, each console comprising a plurality of voltage busses mounted in stacked relation, said busses being mutually insulated, means defining a plurality of channels extending through said busses, each channel having an inlet opening and an outlet opening, a terminal means at each outlet opening spaced from said stacked busses, and control plug means insertable in said channels through said inlet openings and having provision to electrically connect a predetermined bus with the terminal means of the channel in which the plug is inserted, each control channel having means to apply stepped voltage values to the respective busses of the associated console, and means in circuit with each terminal means to energize a lighting circuit in accordance with the voltage applied to the associated terminal means, said means to apply stepped voltage values being a stepped transformer secondary having equally spaced taps connected to said busses, respectively, and a common tap on a return circuit with the associated lighting circuit energizing means, and means to increase the voltage at each bus by a fraction of a voltage step.

8. A lighting control system comprising fader means, a first and a second control channel energized by said fader means, a control console connected in circuit in each control channel, each console comprising a plurality of voltage busses mounted in stacked relation, said busses being mutually insulated, means defining a plurality of channels extending through said busses, each channel having an inlet opening and an outlet opening, a terminal means at each outlet opening spaced from said stacked busses, and control plug means insertable in said channels through said inlet openings and having conductive means to electrically connect a predetermined bus with the terminal means of the channel in which the plug is inserted, each control channel having means to apply stepped voltage values to the respective busses of the associated console, and means in circuit with each terminal means to energize a lighting circuit in accordance with the voltage applied to the associated terminal means, said means to apply stepped voltage values being a stepped transformer secondary having equally spaced taps connected to said busses, respectively, and a common tap on a return circuit with the associated lighting circuit energizing means, and means to increase the voltage at each bus by a fraction of a voltage step, said last mentioned means comprising an additional tap on said secondary and means to connect said return circuit to said additional tap.

9. A lighting control system comprising fader means, a first and a second control channel energized by said fader means, a control console connected in circuit in each control channel, each console comprising a plurality of voltage busses mounted in stacked relation, said busses being mutually insulated, means defining a plurality of channels extending through said busses, each channel having an inlet opening and an outlet opening, a terminal means

at each outlet opening spaced from said stacked busses, and control plug means insertable in said channels through said inlet openings and having conductive means to electrically connect a predetermined bus with the terminal means of the channel in which the plug is inserted, each control channel having means to apply stepped voltage values to the respective busses of the associated console, and means in circuit with each terminal means to energize a lighting circuit in accordance with the voltage applied to the associated terminal means, said means to apply stepped voltage values being a stepped transformer secondary having equally spaced taps connected to said busses, respectively, and a common tap on a return circuit with the associated lighting circuit energizing means, and means to increase the voltage at each bus by a fraction of a voltage step, said last mentioned means comprising an additional tap on said secondary and means to connect said return circuit to said additional tap, said last mentioned means being switch means operable by said control plug means.

10. A lighting control console comprising a housing, a plurality of stacked planar busses mounted in parallel planes and in mutually insulated relation in said housing and insulated therefrom, a plurality of channels extending vertically through and normal to said stacked busses, each channel having an inlet opening and an outlet opening in said housing and a terminal member spaced from the outlet opening thereof, and plug means insertable in said channels for electrically connecting the associated terminal member thereof with a preselected bus.

11. A lighting control console comprising a housing, a plurality of stacked planar busses mounted in parallel planes and in mutually insulated relation in said housing and insulated therefrom, a plurality of channels extending vertically through and normal to said stacked busses, each channel having an inlet opening and an outlet opening in said housing and a terminal member spaced from the outlet opening thereof, and plug means insertable in said channels for electrically connecting the associated terminal member thereof with a preselected bus, said plug means comprising an elongated, electrically conductive shaft having a terminal tip at one end to engage the associated terminal member and an insulation head at the other end, a resilient contact provided on said shaft above said tip to engage a predetermined bus, and insulation means covering said shaft between said tip and said contact and between said head and said contact.

12. A lighting control console comprising a housing, a plurality of stacked planar busses mounted in parallel planes and in mutually insulated relation in said housing and insulated therefrom, a plurality of channels extending vertically through and normal to said stacked busses, each channel having an inlet opening and an outlet opening on said housing and a terminal member spaced from the outlet opening thereof, and plug means insertable in said channels for electrically connecting the associated terminal member thereof with a preselected bus, said plug means comprising an elongated, electrically conductive shaft having a terminal tip at one end to engage the associated terminal member and an insulation head at the other end, a resilient contact provided on said shaft above said tip to engage a predetermined bus, and insulation means covering said shaft between said tip and said contact and between said head and said contact, and a switch associated with each terminal member for operation by a plug means in a predetermined position of the latter.

13. A lighting control console comprising a housing, a plurality of stacked planar busses mounted in parallel planes and in mutually insulated relation in said housing and insulated therefrom, a plurality of channels extending vertically through and normal to said stacked busses, each channel having an inlet opening and an outlet open-

ing on said housing and a terminal member spaced from the outlet opening thereof, and plug means insertable in said channels for electrically connecting the associated terminal member thereof with a preselected bus, said plug means comprising an elongated, electrically conductive shaft having a terminal tip at one end to engage the associated terminal member and an insulation head at the other end, a resilient contact provided on said shaft above said tip to engage a predetermined bus, and insulation means covering said shaft between said tip and said contact and between said head and said contact, and a switch associated with each terminal member for operation by a plug means in a predetermined position of the latter, detent means operable to normally prevent the disposition of the plug means in said predetermined position, and means to obviate the effect of said detent means.

14. A lighting control console comprising a housing, a plurality of stacked planar busses mounted in parallel planes and in mutually insulated relation in said housing and insulated therefrom, a plurality of channels extending vertically through and normal to said stacked busses, each channel having an inlet opening and an outlet opening on said housing and a terminal member spaced from the outlet opening thereof, and plug means insertable in said channels for electrically connecting the associated terminal member thereof with a preselected bus, said plug means comprising an elongated, electrically conductive shaft having a terminal tip at one end to engage the associated terminal member and an insulation head at the other end, a resilient contact provided on said shaft above said tip to engage a predetermined bus, and insulation means covering said shaft between said tip and said contact and between said head and said contact, and a switch associated with each terminal member for operation by a plug means in predetermined position of the latter, detent means operable to normally prevent the disposition of the plug means in said predetermined position, and means to obviate the effect of said detent means, said detent means being a pin provided on the plug head to retain the plug in a raised position, and said obviating means comprising a slot defined in said casing to receive said pin to effect movement of the plug to said predetermined position.

15. A control console comprising a plurality of electrically isolated busses in overlapping parallel spaced arrangement and adapted to receive voltages of different values, electrical conductive means having two electrically conductive contact elements spaced from one another, passage means extending laterally to said busses for receiving said electrical conductive means, contact means at the end of said passage for receiving one of said contact elements and engaging said element in at least two positions, an electrical make and break means for providing an additional incremental voltage and positioned at the end of the electrical conductive means engaging said contact means to close said electrical means, said electrical conductive means positionable in at least two conductive positions in said passage means with one contact element engaging a bus in both positions and the other element engaging said contact means in both positions and said electrical make and break means engaged in the other of said positions to add an incremental voltage to the voltage when desired.

References Cited in the file of this patent

UNITED STATES PATENTS

	249,574	Blake	Nov. 15, 1881
	276,216	Blake	Apr. 24, 1883
	663,367	Shore et al.	Dec. 4, 1900
70	840,537	Weir	Jan. 8, 1907
	2,442,984	Paris	June 8, 1948