

Oct. 8, 1940.

J. KLIEGL

2,217,485

DOOR LATCH

Filed Nov. 1, 1939

2 Sheets-Sheet 1

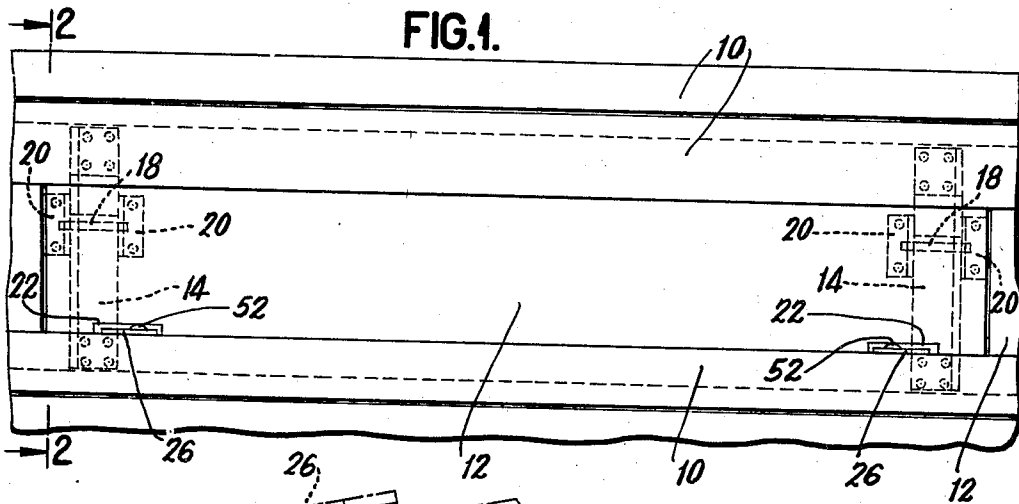

**FIG. 2.**

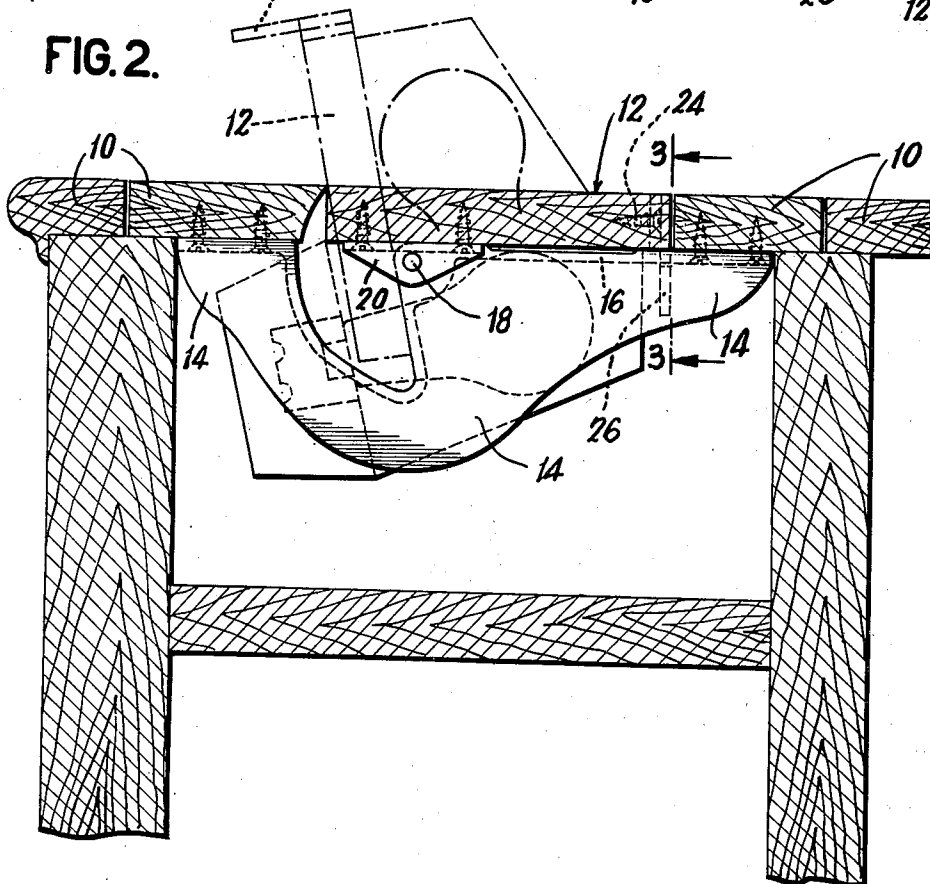

INVENTOR  
*Joseph Klieg*  
BY  
*Cooper, Kerr & Deane*  
ATTORNEYS



# UNITED STATES PATENT OFFICE

2,217,485

## DOOR LATCH

Joseph Kliegl, New York, N. Y., assignor to Kliegl Bros. Universal Electric Stage Lighting Co. Inc., New York, N. Y., a corporation of New York

Application November 1, 1939, Serial No. 302,286

2 Claims. (Cl. 292-103)

This invention pertains to door latches.

The invention is applicable to doors for many purposes, but finds particular utility in connection with the trap doors of disappearing footlights installed in the stage floors of theaters.

An object of the invention is to provide a door latching device which is simple, sturdy, positive, easily operable, and which is, and will remain, flush with the door face, door jamb and floor surfaces when closed.

Further and other objects and advantages will be apparent from the specification and claims, and from the accompanying drawings which illustrate what is now considered the preferred embodiment of the invention.

Figure 1 is a plan view of a footlight door closed, showing the location of the device.

Fig. 2 is an enlarged cross-section on line 2-2 of Fig. 1, showing the door closed (solid lines) and open (broken lines).

Fig. 3 is an enlarged view on line 3-3 of Fig. 2, showing the latch in locking position.

Fig. 4 is a view similar to Fig. 3 but showing the latch unlocked preliminary to opening the door.

Fig. 5 is a view of the back plate which is fixed to the door and on which the latch is pivotally mounted.

Fig. 6 is a detail view on line 6-6 of Fig. 3.

Fig. 7 is a detail view on line 7-7 of Fig. 3.

In the drawings 10 is the stage floor. A disappearing footlight door 12 is shown closed in Fig. 1, while Fig. 2 shows the door both closed (full lines), and open (broken lines).

Brackets 14, underneath the floor, bridge the floor opening. These brackets have upper horizontal flanges 16 (Figs. 2 and 3). Door 12 is hinged to brackets 14 by pins 18 passing through brackets 14 and through ears 20 on the under side of the door.

The device comprises a back plate 22 secured in the edge of door 12 by screws 24. This plate supports latch plate 26, which lies flat against the front surface of plate 22 and is pivotally mounted thereon at 28. On the rear of plate 22 is a boss 30 having a bore 32 in which a spring 34 causes ball 36 to engage depression 38 in plate 26 when the latch is closed, this serving as an impositive lock to hold the latch in locked position and to prevent inadvertent reopening.

When the latch is unlocked and raised as in Fig. 4, it serves as a grip, or handle, for convenience in raising or lowering the door, and as a further aid in that purpose a finger hole 40 is provided in the latch. After door 12 is closed,

latch 26 is lowered from its Fig. 4 position to its Fig. 3 position in which notch 42 of the latch engages the under side of flange 16, toe 44 of the latch rests on stop 46 of plate 22, and the impositive lock above described holds the parts in proper locked relationship, with door 12 closed and the upper surfaces of plate 22 and latch 26 flush with the floor. A projection 48 on plate 22 closes the opening at the pivoted end of the latch.

To open the door, the impositive lock is first released by means of a lever such as a screw driver 50 (Fig. 7) engaging the top rim of hole 40, through a bevelled recess 52 provided for that purpose in plate 22. After the impositive lock is released latch 26 is raised to the position of Fig. 4 and is then used as a handle for raising door 12 to the open position of Fig. 2.

It is to be understood that the invention is not limited to the specific embodiment herein illustrated and described, but may be used in other ways without departure from its spirit as defined by the following claims.

I claim:

1. In a latching device for use on a door adapted for opening and closing an opening in a floor, latching means on an edge of said door for engaging keeper means below said floor when said door is closed, said latching means comprising a plate fixedly secured in the edge of the door, a latch member pivotally mounted with respect to the edge of said door and adapted to lie substantially flush with respect to the top of said door in its latched position, said latch member having an aperture therein for use as a door pull, detent means for releasably holding said member in its latched position, a marginal edge of said aperture defining a tool engaging surface on the latch member which in latched position is located below the level of said floor, said plate having a downwardly directed recess adjacent said latch member adapted to receive a tool for release of the latch member from the keeper means, said recess registering at least partially with said aperture when the parts are in latched position, and means carried by said plate to bridge a gap defined adjacent an end of said member in latched position.

2. In a latching device for use on a door adapted for opening and closing an opening in a floor, latching means on an edge of said door for engaging keeper means below said floor when said door is closed, said latching means comprising a plate fixedly secured in the edge of the door, a latch member pivotally mounted with re-

spect to the edge of said door and adapted to lie substantially flush with respect to the top of said door in its latched position, said latch member having an aperture therein for use as a door pull, detent means for releasably holding said member in its latched position, a marginal edge of said aperture defining a tool engaging surface on the latch member which in latched position is located below the level of said floor, said plate having a downwardly directed recess adjacent

said latch member adapted to receive a tool for release of the latch member from the keeper means, said recess registering at least partially with said aperture when the parts are in latched position, and means carried by said plate to bridge a gap defined adjacent an end of said member in latched position, said latch member engaging said bridging means in latched position.

JOSEPH KLEIPL. 10