

Oct. 18, 1938.

R. C. ENGELKEN

2,133,608

COLOR SCREEN CONTROL

Filed April 2, 1936

2 Sheets-Sheet 1

FIG. 1.

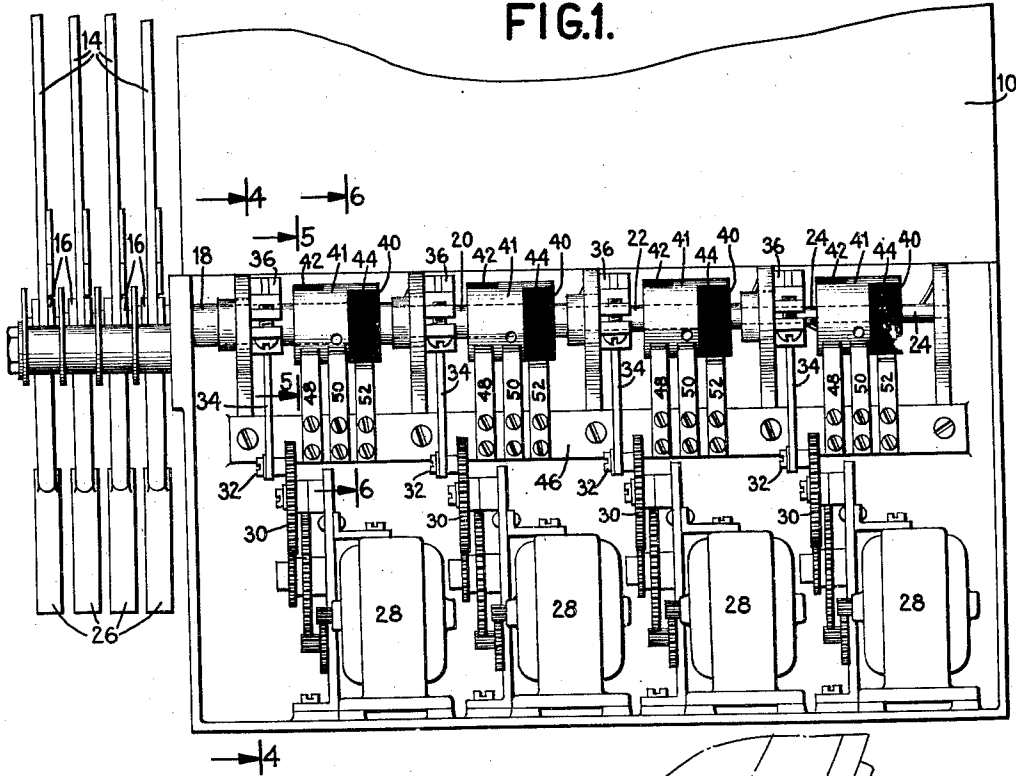

FIG. 2.

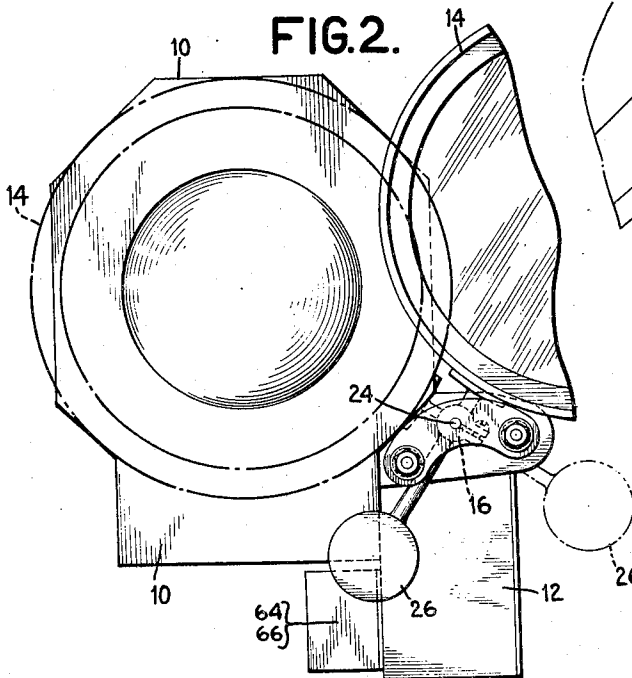
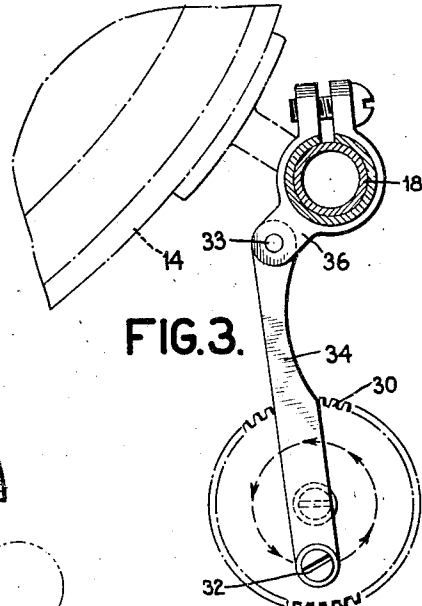

FIG. 3.



INVENTOR
Richard C. Engelken
BY
Cooper, Kerr & Dunham
ATTORNEYS

Oct. 18, 1938.

R. C. ENGELKEN

2,133,608

COLOR SCREEN CONTROL

Filed April 2, 1936

2 Sheets-Sheet 2

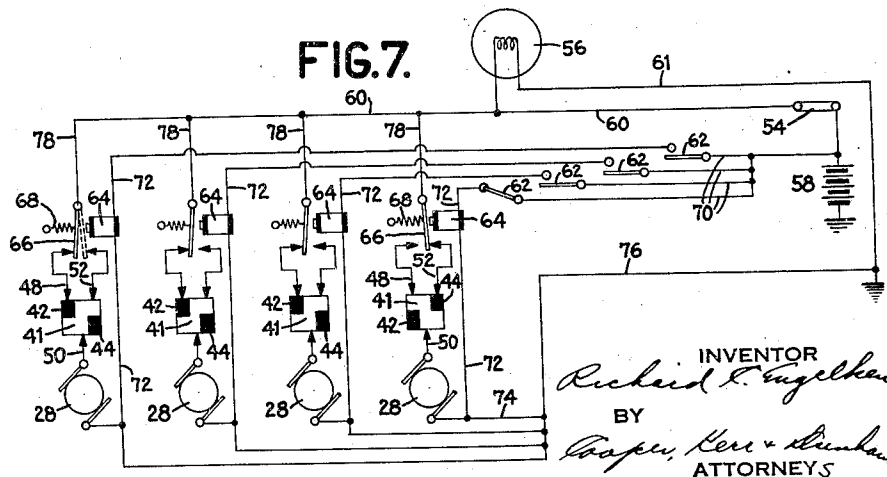
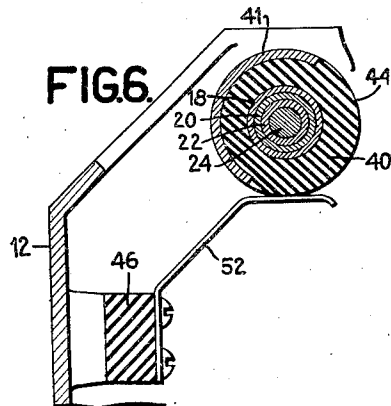
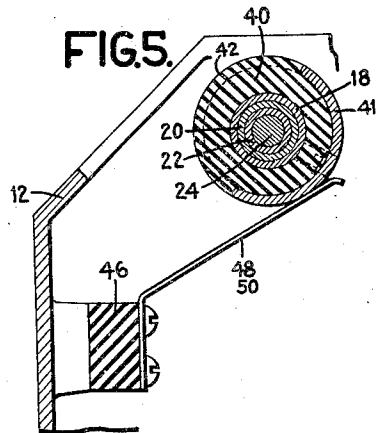
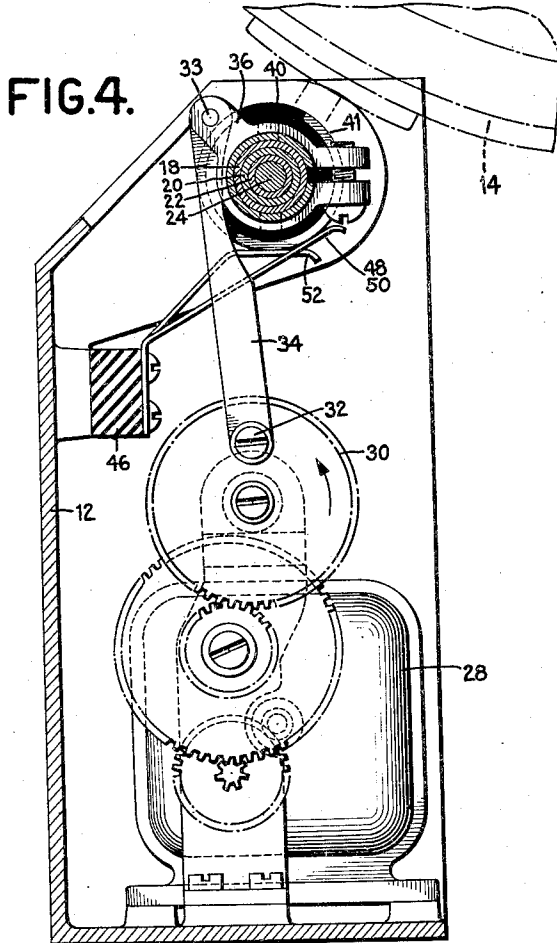

INVENTOR
Richard C. Engelken
BY
Cooper, Kerr & Stumcken
ATTORNEYS

UNITED STATES PATENT OFFICE

2,133,608

COLOR SCREEN CONTROL

Richard C. Engelken, Clifton, N. J., assignor to
Kliegl Bros. Universal Electric Stage Lighting
Co., Inc., New York, N. Y., a corporation of
New York

Application April 2, 1936, Serial No. 72,441

8 Claims. (Cl. 240—3.1)

This invention pertains to the control of color screens in connection with lights such as theatre spotlights and floodlights. Each light is usually equipped with a number of color screens adapted to be selectively placed before the light in order to provide the desired colored effects.

The lights are usually at the back of the auditorium and the screens are mounted on the lights. It is customary for the operator to manipulate the screens by remote control from a position on the stage.

An object of the present invention is to provide mechanism suitable for use with either direct or alternating current, for noiseless control of screens, to start them from rest slowly, to move them quickly and positively, and then bring them to rest slowly and without jar.

Fig. 1 is a side view partly broken away and partly in section of the light with four colored screens and the control mechanism.

Fig. 2 is a view taken from the left of Fig. 1 showing the light and a color screen in its operative and inoperative position.

Fig. 3 is a fragmentary view showing the screen mechanism with the screen in operative position.

Fig. 4 is a cross-sectional view on line 4—4 of Fig. 1 showing the motor, gearing and screen actuating parts with the screen indicated in inoperative position.

Fig. 5 is a detail view on line 5—5 of Fig. 1.

Fig. 6 is a detail view on line 6—6 of Fig. 1.

Fig. 7 is a diagrammatic view showing the relays, rotary switches, motors and wiring diagram.

In the drawings, 10 is a spotlight, to the side of which is attached a box-like housing or frame 12 which supports the screen control mechanism. Four screens 14 are shown, each being secured by a clamp 16 to one of the concentric shafts 18, 20, 22, 24 supported for rotation in the upper part of frame 12. Each screen is balanced about its axis by a counterweight 26.

Mounted on frame 12 are four motors 28, each driving a train of speed reducing gearing. The final gear of each train, designated 30, is provided with a crank pin 32 connected at 33 by link 34 to a crank arm 36 fast on one of the shafts 18, 20, 22 or 24.

Figs. 3 and 4 show the parts just described in their two at-rest positions. In Fig. 4 screen 14 is in normal inoperative position, and in Fig. 3 it is in operative position in front of the light. Fig. 2 shows both positions, the full-line screen at the right being in normal position and the

broken-line screen at the left being in operative position in front of the light 10.

As will be explained, when a motor 28 is energized, it moves its corresponding crank pin 32 through a half revolution and then stops. With crank 32 at either the top or bottom of its stroke and with its corresponding screen at either inoperative (Fig. 4) or operative (Fig. 3) position, the half revolution of crank pin 32 is sufficient to rotate arm 36 and its attached screen from one of its positions to the other. It will be appreciated that during the first and last portions of the stroke, crank 32 is moving at right angles to link 34, the result being that the screen starts slowly and smoothly from its position of rest, accelerates gradually until the crank pin (and screen) reaches its maximum speed at mid-stroke, and then decelerates gradually to the end of the stroke, thus bringing the screen to rest slowly and without jar. The movement is positive at all stages because it has the full power of the motor behind it, yet there is no jar, jerk or noise at any point. The motor control will now be described.

Fast on each shaft 18, 20, 22, 24 is a rotary switch 40 of non-conducting material provided with a metal plate 41 set into the cylindrical surface thereof. The plate is shaped as indicated in Fig. 7 to leave exposed the insulated areas 42, 44 at the ends of the rotary switch. An insulating bar 46 supports a set of three brushes, 48, 50, 52 in contact with each rotary switch. Brushes 48 at the left and brushes 52 at the right of each set are in contact with plate 41 for approximately half the rotary switch travel, and with insulated areas 42, 44, respectively, during the rest of the travel. Brush 50 is always in contact with plate 41. Brush 48 is shown in Fig. 5 and brush 52 is shown in Fig. 6. Brush 50 is a duplicate of brush 48 and is therefore invisible behind brush 48 in Fig. 5.

Operation of the apparatus may readily be understood from Fig. 7 which shows the system in diagrammatic form. When switch 54 is closed, lamp 56 is lighted, current flowing from source 58 through switch 54, line 60, lamp 56 and line 61 to ground.

Each screen is controlled by a switch 62. Whenever a screen is in normal inoperative position its switch 62 is open, and brushes 48, 50 and 52 are related to the rotary switch as indicated diagrammatically in the three units to the left in Fig. 7, brush 48 being on insulation 42, while the other two brushes are on metal plate 41. Above each rotary switch in Fig. 7 is shown

a relay comprising a magnet 64, a switch blade 66, and a spring 68 which normally holds blade 66 to the left, thus closing a circuit to brush 48. However, no current can flow through that circuit because brush 48 is on insulation 42.

Whenever the operator wishes to move a screen from inoperative to operative position he closes the proper switch 62 with the immediate result shown at the left-hand unit (Fig. 7). Current flows from source 58 through line 70, switch 62, lines 72, 74, 76 to ground, thus energizing magnet 64, drawing blade 66 to the right to close the circuit to brush 52. The current then flows from source 58 through line 60, line 78, and blade 66 (in its dotted position in left-hand unit) brush 52, metal plate 41, brush 50, motor 28 and line 76 to ground. Whereupon the motor runs until the rotary switch has rotated from its position in the three left-hand units (Fig. 7) to bring insulation 44 under brush 52, as in the right-hand unit (Fig. 7) thereby breaking the motor circuit and stopping the motor with the screen in front of the lamp and the parts as shown in Fig. 3. Magnet 64 is still energized and therefore continues to hold blade 66 to the right as in the left-hand unit (Fig. 7) until the operator opens switch 62, whereupon the magnet is deenergized, spring 68 draws blade 66 to the left to again energize the motor through brush 48, plate 41 and brush 50, causing the motor to rotate in the same direction as before until insulation 42 gets under brush 48, by which time crank pin 32 has reached the top of its stroke and the screen is in its inoperative position (Fig. 4), the other parts having reached their corresponding positions, as indicated in the three left-hand units of Fig. 7.

It is to be understood that the invention is not limited to the specific embodiment herein illustrated and described, but may be used in other ways without departure from its spirit as defined by the following claims.

I claim:

1. A color control apparatus for a light, comprising in combination, a color screen having operative and inoperative positions, an electric motor operatively connected to said screen, a manually operated switch for placing said motor in circuit with a source of electric motive power for operating said motor, and control means actuated by said motor for causing said motor to turn only a predetermined number of revolutions whereby said screen is moved from one of said positions to the other.

2. A color control apparatus for a light, comprising in combination, a color screen having operative and inoperative positions, an electric motor operatively connected to said screen, a manually operated switch and control means actuated by said motor effective to cause said motor to move said screen from a position of rest at one of said positions to a position of rest at the other of said positions successively upon the closing and opening of said switch.

3. A color control apparatus for a spotlight, comprising in combination, a color screen having operative and inoperative positions, a motor adapted to move said screen, a connection between said motor and said screen adapted to start said screen slowly, then accelerate it to a maximum speed at about midstroke and finally to bring it slowly to rest, said connection including a crank, and manually operable control

means for causing said motor to rotate said crank through half a revolution, whereby said screen is moved from one of said positions to the other.

4. The invention set forth in claim 3 in which the next actuation of said motor will rotate said crank through another half revolution to return said screen to its original position.

5. A color control apparatus for a spotlight, comprising in combination, a color screen having operative and inoperative positions, an electric motor adapted to move said screen, a connection between said motor and said screen adapted to start and stop said screen slowly, a manually operated switch for placing said motor in circuit with a source of electric motive power for operating said motor, and control means actuated by said motor for causing said motor to turn only a predetermined number of revolutions, whereby said screen is moved from one of said positions to the other.

6. A color control apparatus for a spotlight, comprising in combination, a color screen having operative and inoperative positions, an electric motor adapted to move said screen, a connection between said motor and said screen adapted to start and stop said screen slowly, a manually operated switch for placing said motor in circuit with a source of electric motive power for operating said motor, and control means actuated by said motor to cause said motor to move said screen from a position of rest at one of said positions to a position of rest at the other of said positions successively upon the closing and opening of said switch.

7. A color control apparatus for a spotlight, comprising in combination, a pivoted color screen having operative and inoperative positions, an electric motor adapted to move said screen about its pivot, a connection between said motor and said screen adapted to start and stop the movement of said screen slowly, said connection including a rotary motor driven member, an arm operatively connected to said screen and extending laterally from said screen pivot, and a link eccentrically pivoted to said motor driven member and connected to said arm, a manually operated switch for placing said motor in circuit with a source of electric motive power for operating said motor, and control means actuated by said motor for causing said motor to turn only a predetermined number of revolutions whereby said screen is moved from one of said positions to the other.

8. A color control apparatus for a spotlight, comprising in combination, a pivoted color screen having operative and inoperative positions, an electric motor adapted to move said screen about its pivot, a connection between said motor and said screen adapted to start and stop the movement of said screen slowly, said connection including a rotary motor driven member, an arm operatively connected to said screen and extending laterally from said screen pivot, and a link eccentrically pivoted to said motor driven member and connected to said arm, a manually operated switch controlling the operation of said motor, and control means actuated by said motor effective to cause said motor to move said screen from a position of rest at one of said positions to a position of rest at the other of said positions successively upon the closing and opening of said switch.

RICHARD C. ENGELKEN.