

April 19, 1938.

J. LEVY

2,114,963

LIGHT PROJECTOR OR SIMILAR ARTICLE

Filed Nov. 25, 1935

2 Sheets-Sheet 1

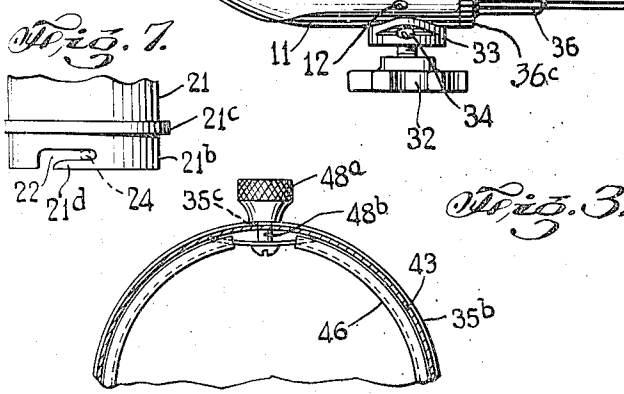
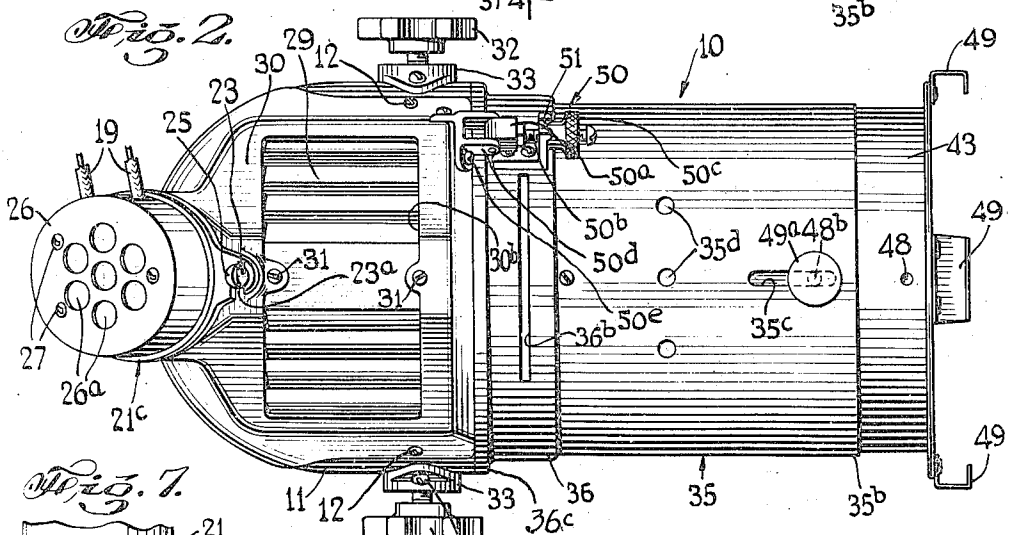
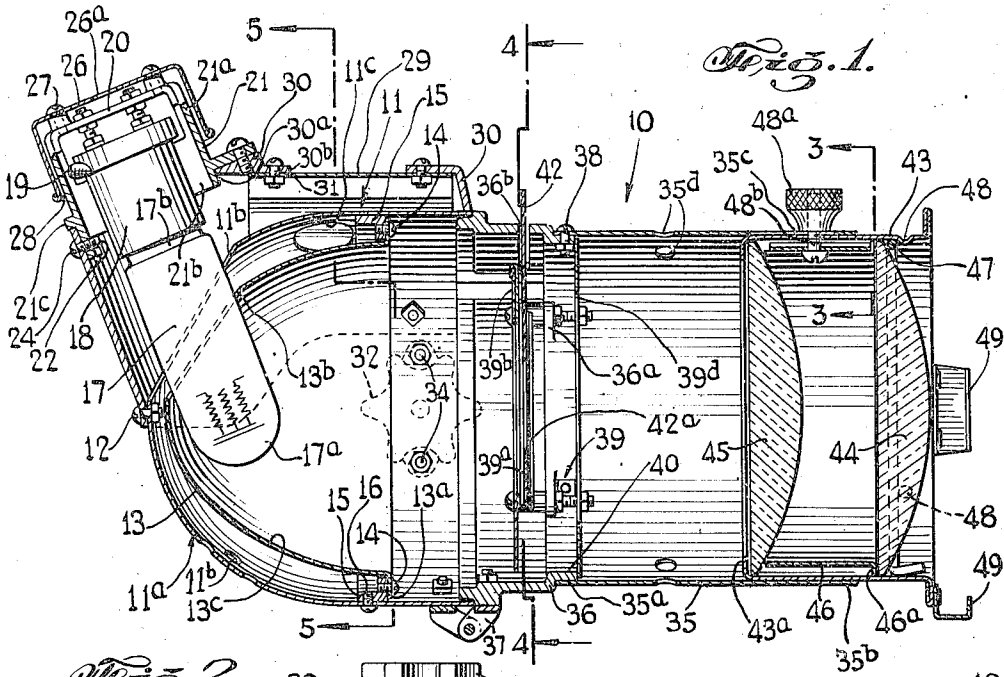

INVENTOR  
JOSEPH LEVY  
BY Louis Barnett  
ATTORNEY

April 19, 1938.

J. LEVY

2,114,963

LIGHT PROJECTOR OR SIMILAR ARTICLE

Filed Nov. 25, 1935

2 Sheets-Sheet 2

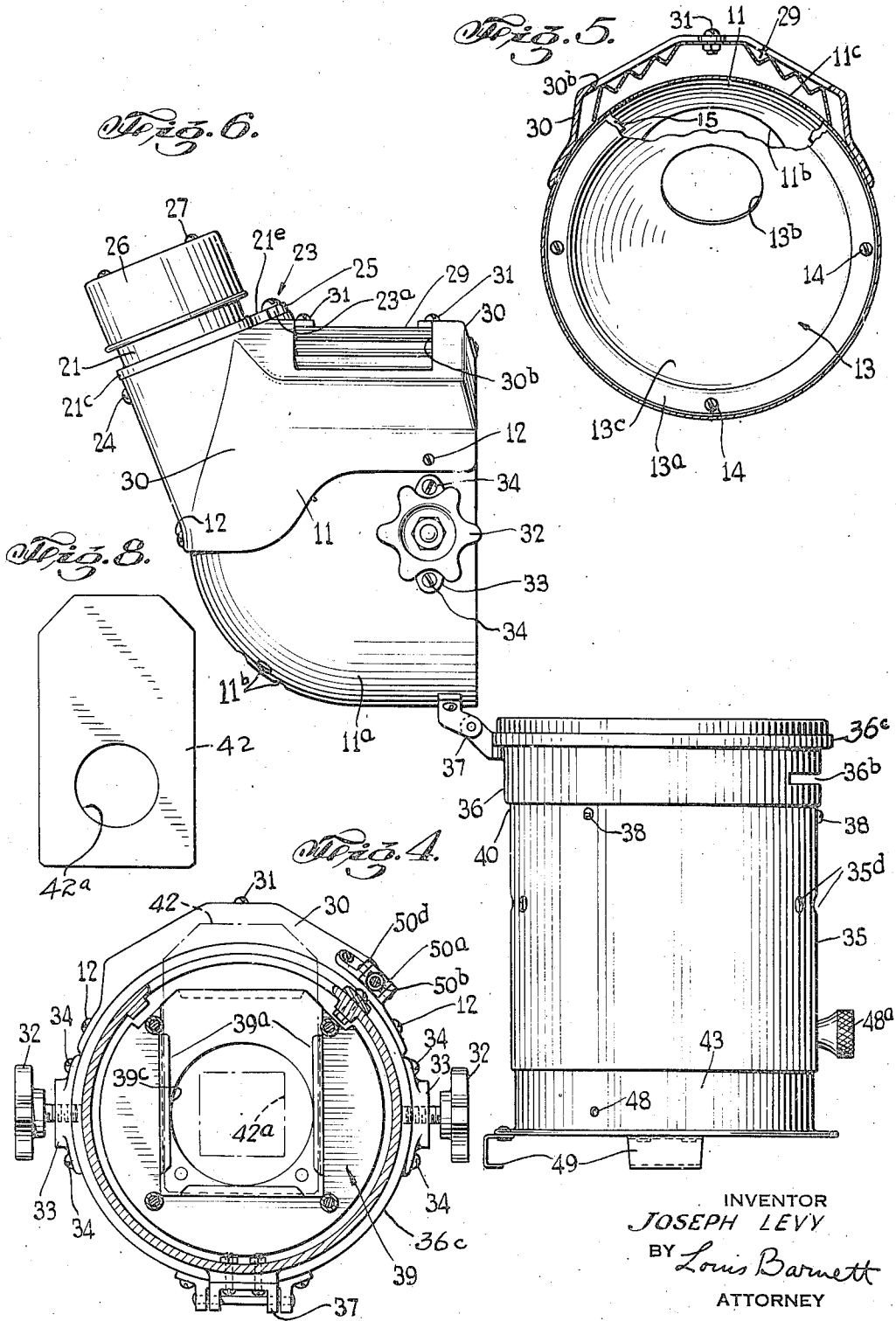

INVENTOR  
JOSEPH LEVY  
BY *Louis Barnett*  
ATTORNEY

## UNITED STATES PATENT OFFICE

2,114,963

## LIGHT PROJECTOR OR SIMILAR ARTICLE

Joseph Levy, New York, N. Y., assignor to Century Lighting Equipment, Inc., New York, N. Y., a corporation of New York

Application November 25, 1935, Serial No. 51,371

5 Claims. (Cl. 240-3)

This invention relates to lighting apparatus and more particularly is directed to spot and flood-light projectors such as used for indoor, stage, display and photographic purposes and for outdoor illumination requiring long or short beam focusing adjustments.

Among objects of the invention is the provision of an improved spot and flood-light projector construction of the character described, which shall comprise a few and simple parts that are readily assembled to form a neat-appearing, compact apparatus which shall be easy to manipulate and adjust, and which shall be inexpensive to manufacture, and practical and efficient to a high degree in use.

Other objects of this invention will in part be obvious and in part hereinafter pointed out.

Certain features herein shown and described, are shown, described and claimed in my application filed, October 25, 1934, Serial No. 749,877, now Patent No. 2,076,240, issued April 6, 1937 for a spot and flood-light projector apparatus of which the present application is a continuation in part.

The invention accordingly consists in the features of construction, combinations of elements and arrangement of parts which will be exemplified in the constructions hereinafter described and of which the scope of application will be indicated in the following claims.

In the accompanying drawings, in which is shown various possible illustrative embodiments of this invention:

Fig. 1 is a side elevational view, in longitudinal section, of a spot and flood-light apparatus embodying the invention.

Fig. 2 is a top plan view of the improved apparatus.

Figs. 3, 4 and 5, are cross-sectional views taken on lines 3-3, 4-4 and 5-5 in Fig. 1, respectively.

Fig. 6 is a side elevational view showing the hinged parts of the housing swung open to give access to the reflector and incandescent lamp.

Fig. 7 is a fragmentary view of the fitting surrounding the lamp receptacle showing the skirted portion thereof formed with the bayonet connecting part and

Fig. 8 is a front elevational view of a diaphragm plate having a circular opening, in Fig. 4 there being shown in dot and dash lines another such diaphragm plate with a square opening position in the slideway.

Referring in detail to the drawings, 10 indicates generally an incandescent-lamp type spot and flood-light projector embodying the inven-

tion constructed to permit adjustment for long or short beam focusing in indoor and outdoor illumination services.

The apparatus 10, is seen to comprise an outer tubular body casing or hood 11 preferably formed with a stamped sheet or cast metal head portion 11a provided with an upper wall member 30, said portion 11a and wall member 30 being firmly secured together by any suitable means, such as bolts 12. An ellipsoidal reflector 13 is fitted within the hood 11 and may be secured in place by screws 14 which rigidly hold the peripheral flange 13a of the reflector 13 against an abutment ring 15, the latter being fastened to a mid-portion of the portion 11a by screws 16. A mid-section of the reflector 13 and the rear curved portion of the head portion 11a may be cut to provide openings 13b and 11b, respectively, in register, for the free passage therethrough of the bulb end 17a of an incandescent lamp 17. Said lamp has its contact or base end 17b fitted into a receptacle or socket 18 and through flexible cable wires 19 connects with a suitable electric power source (not shown) in the well understood manner.

The receptacle 18 may be fixedly secured on a saddle piece 20 to project beyond the upper end 21a of a cylindrical fitting 21, said receptacle 18 extending through said fitting 21 and down beyond the lower end 21b of the latter, as shown in Fig. 1. The fitting 21 may be of a cast or moulded material with a skirted portion having an outwardly extending flange 21c which is located to permit entering the end 21b of said fitting 21 into an opening 30a provided in the upper wall member 30 for rigidly seating said flange 21c therein whereby the receptacle 18 with the lamp 17 is firmly positioned in proper cooperation with the inner side of 13c of the reflector 13.

To positively retain the fitting 21 in its seated position, a suitable locking means is provided in the form of a bayonet type connection 22 and a releasable fastening 23 constructed and arranged in a right-angle relation.

A cap 26 is fitted as a cover over the upper end 21a of the fitting 21, said cap being spaced from the saddle member 20 and firmly retained in position by suitable means, such as screws 27. The cap 26 is provided with perforations or top openings 26a to permit the passage of air through the fitting 21 for cooling the lamp 17 and socket 18. The cap 26 as seen from Fig. 1, does not embrace the cylindrical fitting 21, but is spaced therefrom to provide an annular air passage as at 28.

The connection 22 is provided by a hook por-

tion 21*d* extending from said fitting 21 into the opening 30*a* of the wall member 30 for engaging with a screw 24 which projects into opening 30*a*. The fastening 23 and said connection 22 are positioned in diametrically opposite relation, said connection 22 including an open-end slotted lug 23*a* extending outwardly from the flange 21*c* for engaging with the clamping bolt 25 which is threaded into the member 30. See Figs. 1, 2 and 6.

On opposite sides of the housing 11, below the wall member 30, a pair of spaced handled spindles 32 may be screwed into bossed plates 33 for trunnioning the projector 10 on a suitable support (not shown) in the well understood manner.

The bossed plate 33 is secured to the head portion 11*a* by any suitable means such as bolts 34.

The head portion 11*a*, on an underside thereof at a spaced distance from the upper wall portion 30, has an inlet 11*b* which communicates the space on the rear of the reflector 13 in the interior of the hood 11 with the atmosphere.

Besides the air outlet provided through and under the cap 26, the wall member 30 is formed with the passageway 30*b*, which occupies a substantial portion of the upper side of the housing 11. Said passageway 30*b* is fitted with a baffle plate or louver 29 held by screws 31, said plate preferably being formed of a corrugated sheet for deflecting the air passing from the hood 11 as shown in Figs. 1 and 5.

The head portion 11*a* under the baffle plate or louver 29 may be provided with openings 11*c* to permit air circulating between the reflector 13 and said portion 11*a* to pass therethrough around the plate 29 and out of the housing 11.

The hood 11 has an extension cylindrical light tube 35, which is preferably made of sheet metal and has its inner end 35*a* forming a lap joint 40 with a connecting ring piece 36, the latter being hinged at 37 to the head portion 11*a* on the end of the hood 11 for receiving the light beams from the reflector 13 and the lamp bulb 17*a*. The connecting ring piece 36 may be made of casting to provide sufficient rigidity and strength to take care of the stresses and strains due to the swinging movement of tube 35 on the hinge 37 as shown in Fig. 6. The tube 35 and ring piece 36 may be retained from separating at the lap joint 40 by the bolt 38 said piece having an abutment flange 36*c* for contacting with the hood 11.

The projector 10 may be provided with a simple form of shutter for controlling the shape and spread of the light beam. In the construction here shown, a support 39 is mounted within the ring piece 36, said support is carried by spaced inwardly projecting ribs 36*a* formed integral with the ring piece 36 and located under the joint 40. Said support 39 includes a slideway 39*a* for receiving one of a set of diaphragm plates 42 which has a desired shaped and sized opening 42*a*. Said plate 42, when inserted through a slot 36*b* provided in the ring piece 36 is interposed in the path of the light beams from the lamp 17 and the reflector 13, as is clear from Figs. 1, 2 and 4.

The slideway 39*a* has a shield plate 39*b* spaced therefrom, which, with the support 39 blocks the light beams from passing, except through the center openings 39*c* and 39*d* of said support 39 and plate 39*b*, respectively. The opening 39*c* is adapted to be covered to a desired degree, by the diaphragm plate 42 when seated in the slideway 39*a* in the well understood manner.

The light tube 35 carries at its outer or front end a lens holder 43 which has fitted therein a

pair of spaced lenses 44 and 45. The lens 44 abuts an outwardly extending flange 46*a* of a spacer collar 46, and lens 45 is held in position against an inwardly extending flange 43*a* of the holder 43. The entire lens assembly is held in place by a spring snap ring 47 which fits between the lens 44 and a suitable stop, such as spaced protuberances 48. For adjusting the lenses 44 and 45 to focus the projected light, said lens holder 43 carrying said lenses is made to telescope in tube 35. A suitable engagement means for limiting the movement of said holder 43 relative to the tube 35 is provided, as for example, the pin and slot adjustable connection comprising the screw 48*a* secured to the collar 46 extending up through a slot 35*c* provided at the front end 35*b* of the tube 35, said screw having a finger nut 48*a* for clamping the movable parts in adjusted positions. Additional air inlet holes 35*d* in the tube 35 may be provided inward of the lens holder 43.

If desired, a color screen support 49 may be carried on the front end of the collar 43 as shown in Figs. 1, 2 and 6.

For securing the tube 35 in effective closed position, as shown in Figs. 1 and 2, a latch 50 is provided. Said latch 50 comprises a block 50*a* carrying on threaded shank 50*b* on which a finger nut 50*c* is screw-adjusted. Said block 50*a* is mounted for swing moving on a bracket 50*d* which is fastened in a suitable manner to the member 30 as by bolts 50*e*. An open-ended slotted piece 51 carried by the ring 36 is provided for receiving the shank 50*b* therein, the finger nut 50*c* being adapted to be adjusted to clamp against said piece 51 for locking and securing the tube 35 to the hood 11.

The operation of the improved apparatus 10 will now be apparent. After constructing apparatus 10 from an assembly of parts described above and shown in the drawings, the cable wire 19 is connected to a suitable power source (not shown) in the well understood manner.

The lamp 17 is lit on the application of power to the wires 19 and the light beams from the lamp filament and that reflected from the inner surface 13*a* of the reflector 13 will be projected through the hood 11 and the tube 35, and will pass from the lens 44 for use to illuminate a desired place or object. The heat generated around the lamp base 17*b* and at the socket 18 will be carried off partly by air passing through the fitting 21 and out from the cap 26, and partly by air passing around the base 17*b* of said lamp 17 and out through the louver 29 in passageway 30*b*, cooling air entering the hood 11 through inlets 11*b*. Heat generated at the lamp bulb 17*a* and within the reflector 13 will be carried off, by air entering the hood 11 from the tube 35, circulating around said bulb 17*a* and passing through the reflector opening 13*b* to the rear of the reflector 13, then passing through hood openings 11*c* and hence out of the louver 29. Thus two relatively short air cooling paths are provided for carrying off the heat generated whereby the temperature of the apparatus 10 is kept at a minimum.

Should the reflector 13 or the lamp 17, require inspection, the latch 50 is released and the tube 35 may be swung on the hinge 37, as shown in Fig. 6, giving free access to the reflector 13 and lamp 17.

To remove the lamp 17 for replacement the fastening 23 and connection 22 may be released and fitting 21 with the lamp 17 detached.

With the diaphragm plate 42 removed, the opening 39*c* of the support 39 gives the maximum 75

circular beam cross-section. Smaller size or different shaped beam cross-sections may be obtained by inserting correspondingly shaped diaphragm plates 42 through the slot 36b into the slideway 39a of support 39.

The projected light beam may be focused by simply adjusting the lens holder 43 by loosening the finger nut 48a and movably sliding said holder 43 with the lenses 44 and 45 in the tube 35 toward or away from the reflector 13 and lamp 17.

It will thus be seen that there is provided a device in which the several objects of this invention are achieved and which is adapted to meet the conditions of practical use.

As various other possible embodiments might be made of the above invention and as various changes might be made in the embodiments set forth, it is to be understood that all matter herein set forth as shown in the accompanying drawings is to be interpreted as illustrative and not in a limiting sense.

Having thus described my invention I claim as new and desire to secure by Letters Patent:

1. In a light-projecting apparatus construction of the character described, a hood having an upper wall member, a reflector fitted into said hood with an air passage between the rear side of the reflector and the inner side of the hood, a lamp mounted with a filament portion of the bulb thereof extending through the reflector, said reflector and hood having a through opening of sufficient size to permit the lamp bulb to freely pass therethrough for removably supporting the lamp on said member with a portion of the lamp bulb extending behind said rear side of the reflector, and a lens carrying tube hinged to swing from said hood at the front side of the reflector, said hood having upper and lower spaced openings communicating with said air passage to permit the flow of cooling air around the lamp base, the lamp bulb portions and through said air passage, said member having a baffled outlet adjacent said upper hood opening for the circulating air.

2. The light-projecting apparatus construction defined in claim 1 in which a second baffled outlet is provided adjacent the lamp base for the circulating air.

3. In a light-projecting apparatus construction of the character described, a hood having an upper wall member serving as part of the exterior side thereof, a reflector fitted into said hood with an air passage between the rear side of the re-

lector and hood having a through opening to permit a lamp bulb to freely pass therethrough for removably supporting the lamp on said member with a portion of the lamp bulb extending behind said rear side of the reflector, and a lens carrying tube hinged to swing from said hood at the front side of the reflector, said hood having upper and lower spaced openings communicating with said air passage to permit the flow of cooling air around the lamp base, the lamp bulb portions and through said air passage, said member having spaced baffled outlets for the circulating air, said tube having openings to permit the circulating of cooling air about the lamp bulb portion at the front side of the reflector and through said outlets.

4. In a light-projecting apparatus construction of the character described a hood having an upper wall member serving as part of the exterior side thereof, said member formed with an opening for seating a lamp receptacle fitting and with an air outlet spaced from and alongside said opening, a louver, the rim of said outlet being formed to retain said louver, a reflector fitted in the hood with an air passage between the rear side of the reflector and the inner side of the hood, said reflector being located directly under said member and outlet louver, said louver outlet communicating with said passage, and locking means for releasably securing the fitting in said position in said opening whereby said receptacle fitting together with the lamp receptacle fitting may be readily dismounted from the member.

5. In a light-projecting apparatus construction of the character described having a hood and a lens system, a tube hinged to swing from said hood for adjustably carrying said lens system, said hinged tube including a ring-piece end formed with an abutment flange portion serving as a coupling joint with the hood on swinging the tube in alignment on the hinge, and a diaphragm plate support mounted within said ring piece at a spaced distance from the lens system, said ring-piece having a slot communicating said support with the exterior of the apparatus for inserting and removing diaphragm plates to vary the cross-section of light beams projected through the tube from said hood before passing through the lens system, said hinged tube when swung out of said alignment giving free access to the interior of the hood.

JOSEPH LEVY.