

April 6, 1937.

J. LEVY

2,076,240

SPOT AND FLOODLIGHT PROJECTOR APPARATUS

Filed Oct. 25, 1934

2 Sheets-Sheet 1

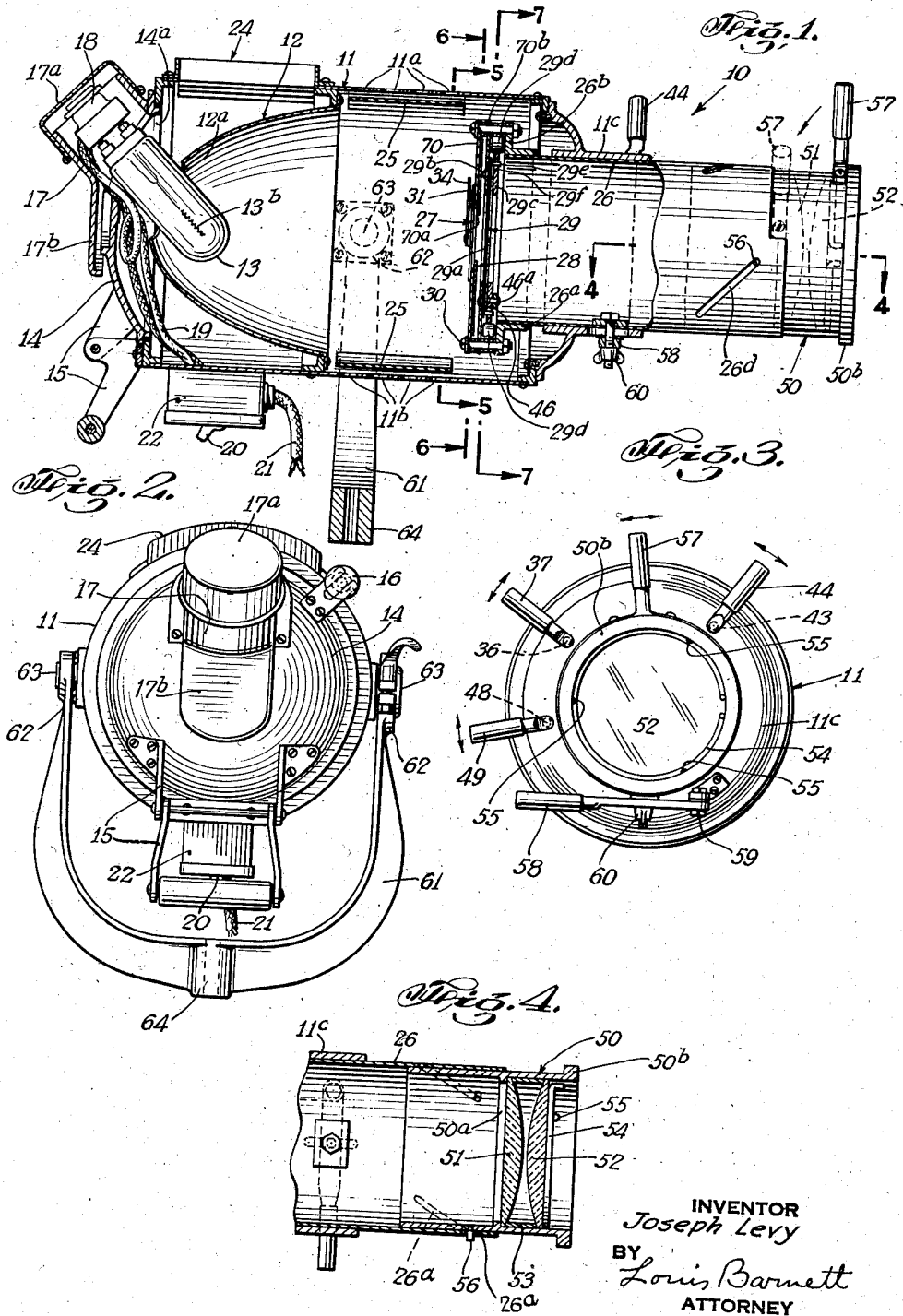

INVENTOR  
Joseph Levy  
BY  
Louis Barnett  
ATTORNEY

April 6, 1937.

J. LEVY

2,076,240

SPOT AND FLOODLIGHT PROJECTOR APPARATUS

Filed Oct. 25, 1934

2 Sheets-Sheet 2

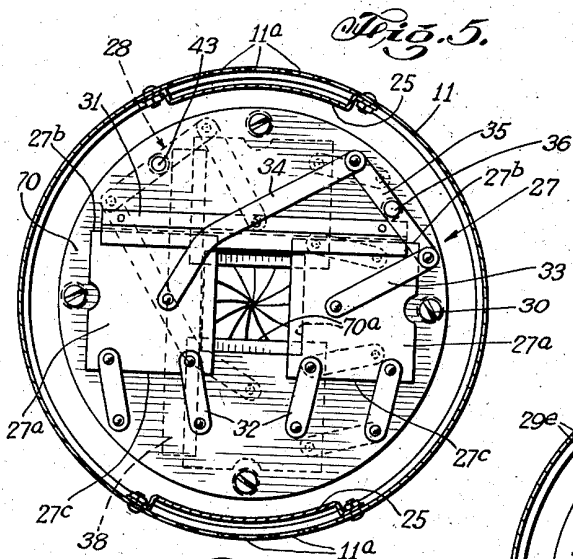

Fig. 7.

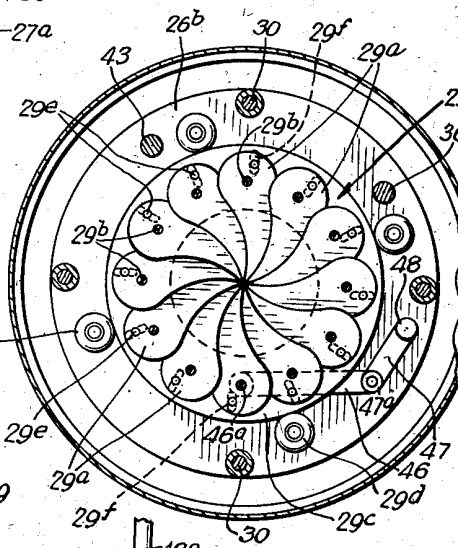

Fig. 6.

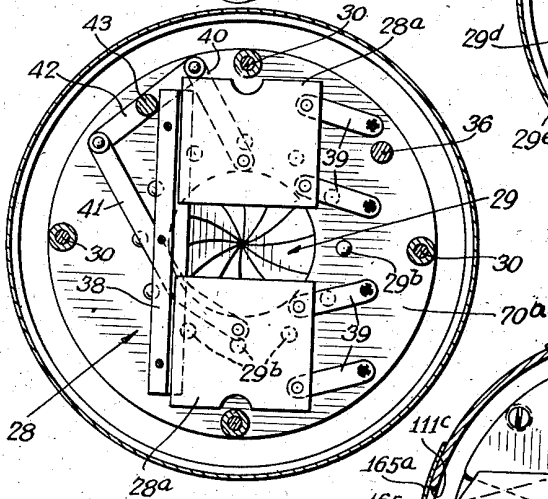

Fig. 8.

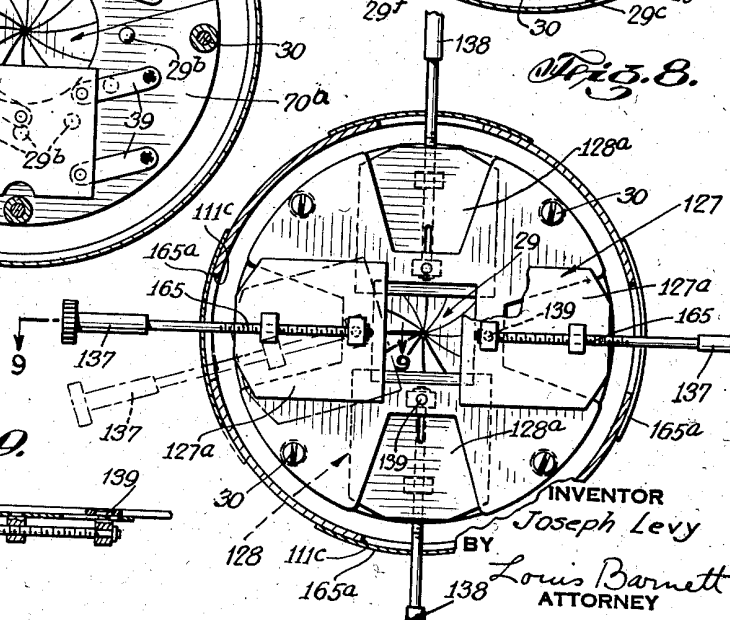
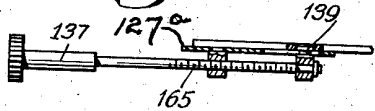

Fig. 9.



INVENTOR  
Joseph Levy  
BY  
Louis Barnett  
ATTORNEY

# UNITED STATES PATENT OFFICE

2,076,240

## SPOT AND FLOODLIGHT PROJECTOR APPARATUS

Joseph Levy, New York, N. Y., assignor to Century Lighting Equipment, Inc., New York, N. Y., a corporation of New York

Application October 25, 1934, Serial No. 749,877

3 Claims. (Cl. 240—3)

The invention relates to light projectors and more particularly is directed to spot and flood-light apparatus such as used for indoor or outdoor illumination in stage, display and photography lighting, and for other like purposes requiring either long or short range adjustments.

Among the objects of the invention is to generally improve spot and flood-light projecting apparatus of the character described whereby the construction thereof comprising few and simple parts, which shall be readily assembled, which shall be easily manipulated and adjusted, which shall be relatively cheap to manufacture, and which apparatus shall be practical and efficient to a high degree in use.

Other objects of this invention will in part be obvious and in part hereinafter pointed out.

The invention accordingly consists in the features of construction, combinations of elements and arrangement of parts which will be exemplified in the constructions hereinafter described and of which the scope of application will be indicated in the following claims.

In the accompanying drawings, in which is shown various possible illustrative embodiments of this invention:

Fig. 1 is a side elevational view of a spot and flood-light apparatus embodying the invention, partly broken away to show the interior construction;

Figs. 2 and 3 are rear and front end views, respectively, of the improved apparatus shown in Fig. 1;

Figs. 4, 5, 6 and 7 are cross sectional views taken on lines 4—4, 5—5, 6—6 and 7—7, respectively, in Fig. 1;

Fig. 8 is a cross sectional view showing a modified form of adjustable framing shutter construction; and

Fig. 9 is a sectional view taken on lines 9—9 in Fig. 8.

Referring in detail to the drawings, 10 indicates generally an incandescent-lamp type, spot and flood light apparatus embodying the invention, constructed and arranged for long or short range work and adapted for service requirements in outdoor and indoor illumination. The apparatus 10 is seen to comprise a tubular body or housing hood 11, preferably formed of sheet metal, having an ellipsoidal reflector 12 fitted into a rear portion thereof. The curved mid-section of said reflector 12 may be cut out, at 12a, to permit the free swinging of the bulb end of an incandescent lamp 13 with a breach-cover 14, the latter being

adapted to seat on the rear end of the hood 11, as shown in Fig. 1. Said breach-cover 14 forms a closure for the rear end of the hood 11 and may be swingably mounted from the hood through suitable means, such as hinged supports 15, said cover 14 being retained in seated position by a finger screw fastener 16, as shown in Fig. 2.

The breach-cover 14 has an opening 14a where-through the incandescent lamp 13 extends. Said opening 14a has formed to extend outwardly thereof compartment extension 17 for communicating the interior of the hood 11 with the reflector 12. Said compartment extension 17 has secured therein an electric light socket or receptacle 18. The latter connects the lamp 13 in circuit with the flexible leads 19 which in turn through a suitable switch 20 connects with conductor cable 21. The cable preferably terminates with a suitable attachment plug (not shown) for tapping an electric power supply in the well understood manner. Said switch 20 may be enclosed in a fitting or box 22 carried on the under side of the hood 11, said box being made to receive the ends of leads 19 extending from the hood between the cover 14 and reflector 12 as is shown in Fig. 1.

The compartment extension 17 may be provided with a cap 17a which gives access to the receptacle 18, a lower portion wall of said compartment member 17 being extended at 17b and spaced from the cover 14 to provide an inlet 23 for the passage of cooling air therethrough, around the base of the bulb 13, through the hood 11, behind the reflector 12, and thence out through louvre or outlet 24.

The upper and lower wall portions of the hood 11 in front of the reflector 12 have top and bottom vent holes 11a and 11b, respectively, which permit passage of cooling air to circulate about the bulb end of the lamp 13 and through the hood in front of said reflector 12. To make these perforated wall portions of the hood light-proof, interposing baffles or screen members 25 are provided inside the hood spaced from said holes 11a and 11b, as shown in Figs. 1 and 5.

The front end of the hood 11 has a sleeve fitting 11c which carries a cylindrical light tube 26 having an axis aligned with the direct and reflected light beams projected from the lamp filament 13b and reflector 12. The inner end 26a of said tube extends within the hood 11, and has an outwardly extending flange 26b which supports a pair of horizontal or cross framing shutters 27, a pair of vertical or up and down framing shutters 28 and an iris shutter 29. These

three sets of shutters may form a unit structure which is secured to said flange 26b by any suitable means such as bolts 30.

The horizontal or cross framing shutters 27 may comprise the aligned cooperating rectangular-shaped slides 27a which have one edge 27b of each adapted to ride on a track piece 31. The opposite edge portions 27c of each of said slides may be retained for movement to hold said slides against the track piece 31 by one or more sets of links 32. To provide movement of the slides 27a in unison to and from each other across the center of the light tube 26, links 33 and 34 connecting with a bar 35 are provided. Said bar 35 is pivoted at 36 and connects with a lever handle 37 which extends outside the front end of the hood 11 as shown in Fig. 3, so that when said handle 37 is moved in the directions of the arrows, the slides 27a are correspondingly moved to and away from each other. Rail member 31, links 33 and 34, bar 35, and pivot 36 together with the slides 27a are supported on the rear side of a disc plate 70 having a square opening 70a, said plate being rigidly mounted in position by the bolts 30, as shown in Fig. 5.

The vertical shutters 28 which are situated between the horizontal shutters 27 and the iris shutter 29 are carried on the front side of disc 70 and may comprise slides 28a similar in all respects to slides 27a but positioned to operate up and down instead of across, as is clearly shown in Figs. 5 and 6, said slides 28a being adapted to ride on track piece 38 and having sets of guiding links 39 similar to the links 32. These slides 28a are connected for cooperative movements by links 40 and 41 which are interconnected by a bar 42, said bar being pivoted at 43 and swingably controlled through a lever handle 44 so that when the latter is moved in the directions of the arrows shown in Fig. 3, the slides 28a are correspondingly moved up and down, that is, to and away from each other, as is clear from Fig. 6.

The iris shutter 29 may be of any well-known construction, but as here shown comprises a plurality of blades 29a, each pivoted at 29b on a plate disc 70a. Each of the blades 29a carry fix pins 29e which engage in slots 29f in an annular disc 29c, said disc 29c being mounted for rotation between spaced bearing roller 29d, as shown in Fig. 7. As shown in Figs. 1 and 7, the bearing rollers 29d are supported on the outturned flange 26b of the tube end 26a. The iris shutter is controlled through links 46 and 47, one end of the link 46 being pivoted to the disc 29c as at 46a, the other end of said link 46 connecting with the free end 47a of the link 47. The end 47b of said link 47, opposite said free end 47a, is pivoted as at 48, and is rocked through movement of the lever handle 49 situated on the front end of the hood 11 to open and close the iris shutter 29. On moving said handle 49 in the directions of the arrows shown in Fig. 3, through the links 46 and 47, the blades 29a swing in unison with the turning of the disc 29c causing the iris to open and close.

The light tube 26 carries at its front end a lens holder 50 which has fitted therein a pair of lenses 51 and 52, lens 51 being fitted against an inwardly extending flange 50a on the holder 50, and lens 52 being separated from said lens 51 by a spacer collar 53. The entire lens assembly is held in place by a spring snap ring 54 which fits between the lens 51 and a suitable stop such as spaced protuberances 55. For adjusting the lenses 51 and 52 to focus the projected light, said lens holder 50 is made to telescope in the tube 26 and

a suitable engagement means for limiting the movement of the holder 50 relative to said tube 26 is provided as for example spiral slots 26a in tube 26 through which the pins 56 from the holder 50 extend. For making the lens adjustment, a suitable handle 57 is provided on an outwardly extending rim flange 50b. Thus by moving the handle 57 in the directions of the arrows shown in Fig. 3, the lens holder is telescopically moved in and out of the tube 26 and the lens is adjusted with relation to the source of light in the hood 11. For adjusting the power range, the light tube 26 with the lens holder 50 may be moved in the sleeve 11c so that said shutters, holder and lenses are moved as a unit with relation to the source of light. To facilitate this movement, lever handle 58 is provided, the latter being pivoted at 59 on the hood end 26b. Said adjustment may be locked by any suitable means such as wing screw and nut connection 60.

A suitable tilting and swivelling mounting may be provided as part of the apparatus 10, said mounting comprising a U-shaped yoke 61 which terminates in spaced pivots 62 forming a trunnion with extensions 63 from the housing 11, the lower mid-portion of the yoke 61 being provided with a swivel support 64, as is clearly shown in Fig. 2.

The operation of the improved apparatus will now be apparent. After constructing the parts of the apparatus 10 and assembling same as described above and shown in Fig. 1 of the drawings, cable 21 is connected to a suitable power source (not shown) in the well understood manner.

The lamp 13 will be lit by operating the switch 20 to close the circuit and light beams from the lamp filament 13a and from the inner surface of the reflector 12 will be projected through the hood, shutters, light tube and lenses. The heat around the base of the lamp 13 will be carried off by air passing through the passage 23 around the base of said lamp and out through the louvers 24. Heat generated at the bulb of said lamp 13 and within the reflector 12 will be carried off by the air entering the lower holes 11b, circulating through the hood and around said bulb and pass out through the upper holes 11a. The baffles 25 serve to shield any leakage of light through said openings 11a and 11b. Two separate and relatively short air cooling paths are thus provided whereby the temperature of the apparatus is kept at a minimum.

Should the lamp 13 burn out or require inspection, the breach-cover 14 may be swung open on the hinge supports 15 carrying the lamp 13 therewith, the finger screw fastener 16 being first loosened to unlock said cover from the hood. The opening 12a in the reflector is made sufficiently large to permit the swinging of the bulb of lamp 13 therethrough and the lamp may then be readily inspected, removed or replaced.

If the receptacle 18 in compartment extension 17 should require inspection or replacement, the cap 17a may be removed for such purposes.

The apparatus 10 may be tilted or swivelled, by trunnioning the hood 11 on the yoke 61 or swivelling the latter on support 64, or may be moved by simultaneously combining both the tilting and swivelling movements. Thus the apparatus 10 may be positioned for projecting light in any direction and may be kept in constant motion to have the projecting light follow any moving object.

With the shutters 27, 28 and 29 open wide, by operating handles 57 and 58, the projected light 75

beams have the power range adjusted and may be focused to give spot or flood lighting. By operating the iris shutter control handle 49, the size of the projected spot may be regulated through opening and closing the iris shutter. Likewise by operating the horizontal framing shutter handle 37 and the vertical framing shutter handle 44, the shape of the light beam may be selectively adjusted either horizontally or vertically. In each of these cases, the pairs of slides 27a and 28a will move to and/or away from each other.

In Figs. 8 and 9, there is shown a modified form of horizontal or cross framing shutters 127 and vertical or up and down framing shutters 128 which are adapted to be set in angular relation. Here each of the slides 127a and 128a of said shutters 127 and 128, respectively, are individually controlled by oppositely disposed lever handles 137 and 138, respectively. Said slides 127a and 128a are mounted for in and out movement by means of the threaded connection of the lever screw 165 and each pair of cooperating slides may be tilted out of alignment with respect to the other by swinging the handles 137 and 138 on the pivotal mounting 139 as illustrated by the full and dotted line positions of handle 137 in Fig. 8. With this construction, the beam as it passes through the shutters may be varied in size and may be given various regular and irregular shapes. Shields 165a are provided about each of the handles 137 and 138 to shield the light from passing out of the slots 111c through which the said levers extend, as shown in Fig. 8. If desired, the shutters 127 and 128 may be combined with an iris shutter such as described above and as shown in Fig. 1.

It is to be understood that the one or all of these shutters may be omitted from the apparatus 16 in carrying out some of the objects of the invention, said shutters serving to facilitate shaping the projected beam for various requirements in stage display and photographic lighting. It will thus be seen that there is provided a de-

vice in which the several objects of this invention are achieved and which is adapted to meet the conditions of practical use.

As various other possible embodiments might be made of the above invention and as various changes might be made in the embodiments set forth, it is to be understood that all matters herein set forth as shown in the accompanying drawings is to be interpreted as illustrative and not in a limiting sense.

Having thus described my invention I claim as new and desire to secure by Letters Patent:

1. In a spot and flood-light projector apparatus, a hood fitted with a reflector, a breach-cover end-closure carrying a lamp swingably mounted on a rear end of said hood for moving the lamp into and out of an effective position with respect to the reflector, said lamp being mounted in a receptacle housed in a compartment formed in said end-closure, said hood-closure and compartment having a passage to serve as an air inlet, and said hood having spaced outlets located to permit the passage of air along the front and rear of said reflector.

2. A spot and flood-light projector apparatus including a hood, a tube extending into and from an end of said hood, and a unitary organization mounted on the inner end of the tube and comprising an apertured plate, a set of vertically movable framing shutters mounted on one side of said plate, a set of horizontally movable framing shutters mounted on the other side of said plate in cooperative relation to said vertically movable shutters, and control means extending outwardly from said tube and forwardly of said hood for moving each of said set of framing shutters.

3. The projector apparatus defined in claim 2 in which said means permits at least one of said shutters to be selectively positioned in either alignment or angular position with respect to another of said shutters.

JOSEPH LEVY.