

Sept. 17, 1935.

J. KIEGL

2,014,573

SPOTLIGHT AND LAMP SUPPORT THEREFOR

Filed April 13, 1934

2 Sheets-Sheet 1

FIG. 1.

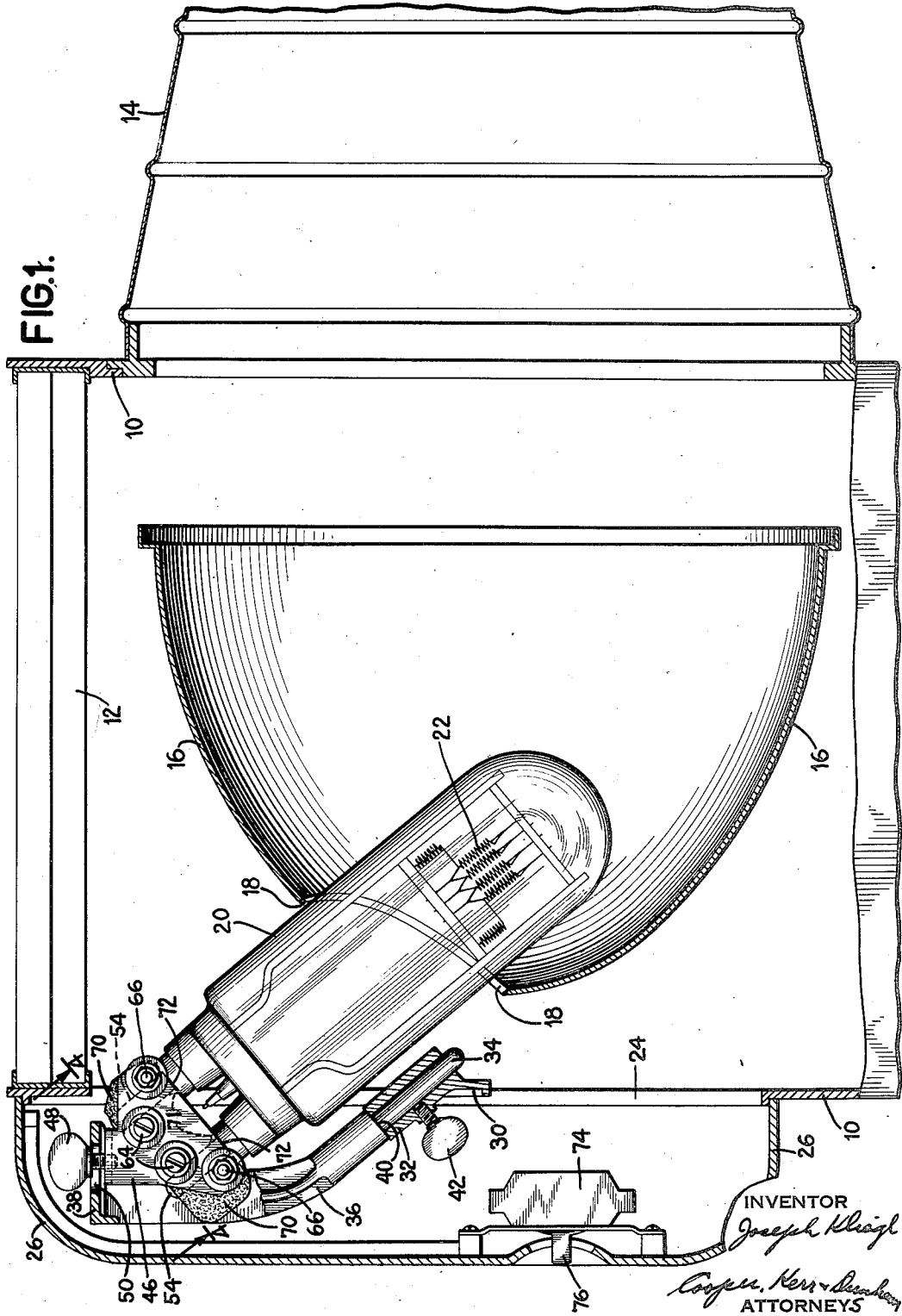

Sept. 17, 1935.

J. KIEGL

2,014,573

SPOTLIGHT AND LAMP SUPPORT THEREFOR

Filed April 13, 1934

2 Sheets-Sheet 2

FIG. 2.

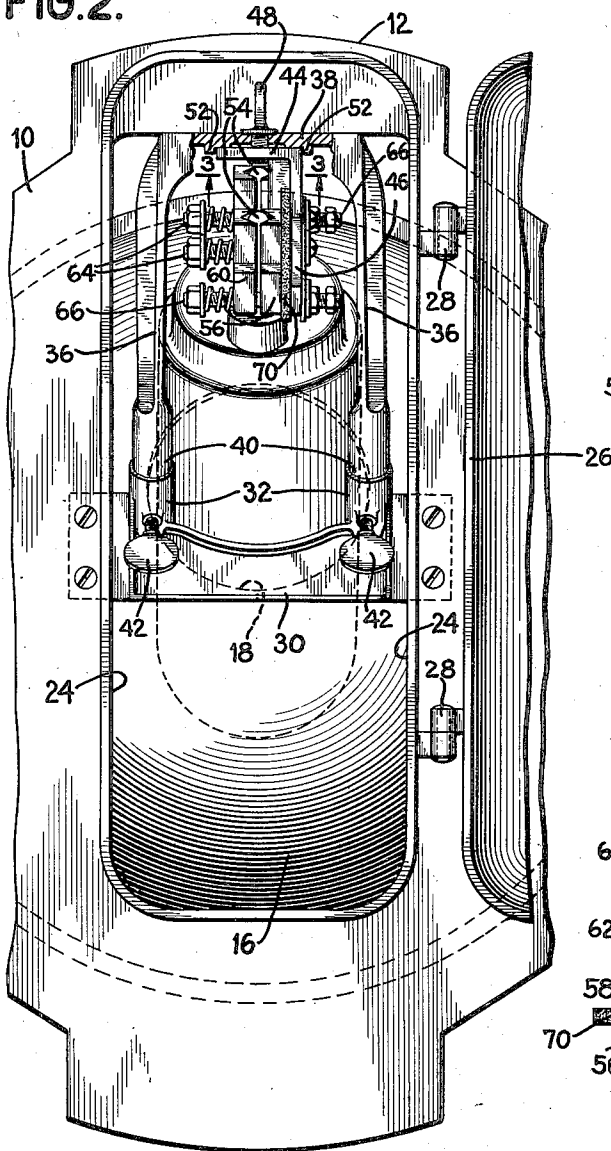

FIG. 3.

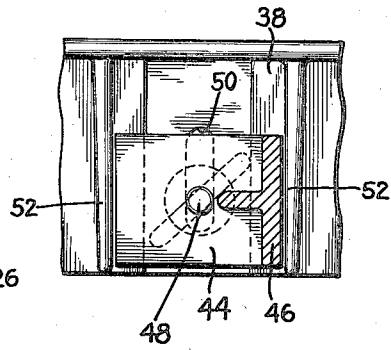
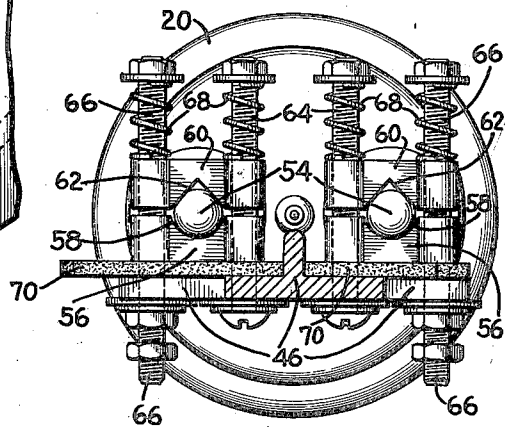

FIG. 4.



INVENTOR  
*Joseph Kiegl*  
BY  
*Cooper, Kerr & Dunham*  
ATTORNEYS

# UNITED STATES PATENT OFFICE

2,014,573

## SPOTLIGHT AND LAMP SUPPORT THEREFOR

Joseph Kliegl, Queens, N. Y., assignor to Kliegl  
Bros. Universal Electric Stage Lighting Co. Inc.,  
New York, N. Y., a corporation of New York

Application April 13, 1934, Serial No. 720,369

3 Claims. (Cl. 240—44.2)

This invention pertains to spot lights of the type largely used in theatres, and has for an object the provision of means for supporting a lamp in such manner that the lamp may be instantly removed and replaced with the assurance that the light source of the lamp will, without adjustment, resume its proper position with reference to the reflector and other parts of the apparatus.

Another object is to so design the support that lamps may be removed therefrom and instantly and accurately replaced therein. Furthermore, after the support has been given preliminary minor adjustments to properly locate the filament of a lamp vertically, longitudinally, angularly and rotationally, that lamp may be instantly replaced by any other similar lamp without the necessity of making further adjustments.

Further and other objects and advantages will be apparent from the specification and claims, and from the accompanying drawings which illustrate what is now considered the preferred embodiment of the invention.

Fig. 1 is a longitudinal cross-section of a spot light with the lamp and its support.

Fig. 2 is a rear view of Fig. 1 (looking from left to right) with the door open.

Fig. 3 is a detail view on line 3—3 of Fig. 2.

Fig. 4 is a detail view on line 4—4 of Fig. 1.

The spot light comprises a housing 10 with a ventilating roof 12, and having a conical projection 14 which usually supports lenses (not shown). Within the body of the housing is a suitable reflector 16 which may be of ellipsoidal shape as shown in the drawings. The rear of the reflector is provided with an opening 18 to accommodate the body of a lamp 20 which is illustrated as being of the tubular or incandescent type, supported with its filament 22 at the most advantageous point in the reflector, which is usually, as shown, at the focus of the ellipsoid.

The lamp is supported in the particular inclined and rotational position recommended by the lamp manufacturer to obtain the maximum lamp efficiency.

At the rear of the housing is an opening 24 through which the lamp may be removed or replaced. A door 26, hinged at 28 on the housing, is provided to close the opening and enclose the lamp and its support while the apparatus is in use. Across the opening is a fixed bracket 30 having two sockets 32 drilled therein parallel to the angle prescribed for a particular kind of lamp. These sockets are adapted to snugly receive the two parallel shanks 34 of a bifurcated

frame 36 having a flat top 38. Shoulders 40 at the upper ends of shanks 34 serve to accurately locate frame 36 vertically. It will be apparent that frame 36 will always assume the same position when its shanks are fully inserted in sockets 32. Thumb screws 42 may be used if desired to prevent inadvertent displacement of the frame.

Underneath the flat top 38 is a support for the lamp comprising in part an angle bracket having a horizontal top flange 44 and a vertical depending flange 46. A thumb screw 48 passing through slot 50 in 38 and threaded into flange 44 serves to hold flange 44 in any adjusted position within the limits of the slot and of ribs 52 on the under side of top 38.

The lamp has two parallel cylindrical terminals 54, 54, and flange 46 serves to support two spring-sockets side by side (Fig. 4) one for each terminal 54. Each socket comprises a block 56 having an arcuate recess as at 58, together with a cooperating block 60 having a V-shaped recess as at 62. Each pair of blocks 56—60 is bolted to flange 46 by a short bolt 64 and a long bolt 66, the long bolts being provided with extra nuts to secure the current supply wires (not shown). The sockets are assembled as in Fig. 4, with compression springs 68 surrounding the bolts and pressing blocks 56 and 60 together so as to firmly but resiliently hold stems 54 and thus support the lamp in its predetermined position. A sheet 70 of insulating material is placed between flange 46 and blocks 56. Current flows into one bolt 66, through one socket 56, 60 and the terminal 54 engaged by that socket, then through filament 22 and out through the other terminal 54 and its associated socket 56, 60 and its bolt 66.

The lower edges of recesses 58 and 62 are beveled off as indicated at 71 (Fig. 1), and the ends of terminals 54 are rounded as shown, in order to permit ready insertion of the terminals into their sockets. Shoulders 72 on the lamp limit the travel of the terminals into the sockets.

With the above structure in mind, and assuming that the lamps are alike in their dimensions it will be clear that frame 36 and the lamp may be removed from the housing by simply opening door 26 and pulling shanks 34 from their sockets; that any lamp may be instantly removed from its sockets; that the same or similar lamp may be placed in the support with the assurance that its filament will be located just as the filament it replaced was located, vertically, longitudinally, angularly and rotationally; the rotational feature being very important when the filament is of a flat type, as shown.

Mounted on door 26 is a switch 74 having a lever 76 operable while the door is either open or shut.

5 It is to be understood that the invention is not limited to the specific embodiment herein illustrated and described, but may be used in other ways without departure from its spirit as defined by the following claims.

10 1. In a spot light, in combination, a housing, an incandescent lamp with terminals projecting from one end thereof parallel to the axis of said lamp, a reflector having a lamp passage in the rear thereof, a support having resilient sockets for engaging said terminals to hold said lamp non-rotatably in said passage with its axis at a pre-15 determined inclination from the horizontal and its filament at a predetermined position in said reflector, said support being outside said reflector and adjustably mounted on a frame having shanks adapted to be held by sockets in said housing, the inclination of said sockets being parallel to the operative axis of said lamp, said support and lamp being removable from said spot light only in a direction parallel to said lamp 20 axis.

25 2. In a spot light, in combination, a housing, a reflector in said housing, an opening in said housing, a bracket across said opening, sockets carried by said bracket, a frame having shanks

adapted to enter said sockets at a fixed angular position, means limiting the vertical movement of the shanks in said sockets, a top in said frame, a support, means holding said support against the top of said frame in any one of a plurality of positions of adjustment, a lamp socket carried by said support, all for the purpose of holding a lamp in the most efficient position of operation with respect to said reflector.

3. In a spot light, in combination, a housing, 10 a reflector having a lamp passage in the rear thereof, an opening in said housing to the rear of said reflector, a horizontal bracket fixed across said opening, parallel sockets carried by said bracket, a bifurcated frame having parallel 15 shanks adapted to enter said sockets, shoulders on said shanks to determine their vertical movement, a flat top in said frame with a slot therein, spaced parallel ribs on the lower face of said flat top, a support comprising in part an angle 20 bracket having a horizontal top flange and a vertical depending flange, means holding said angle bracket against said top flange in any one of several positions determined by said slot and said ribs, resilient sockets for engaging lamp ter- 25 minals in non-rotative position carried by said depending flange, and electrical connectors therefor.

JOSEPH KLEGL.