

Sept. 6, 1932.

J. H. KLIEGL

1,875,814

COLOR SCREEN CONTROL

Filed April 27, 1929

2 Sheets-Sheet 1

FIG. 1.

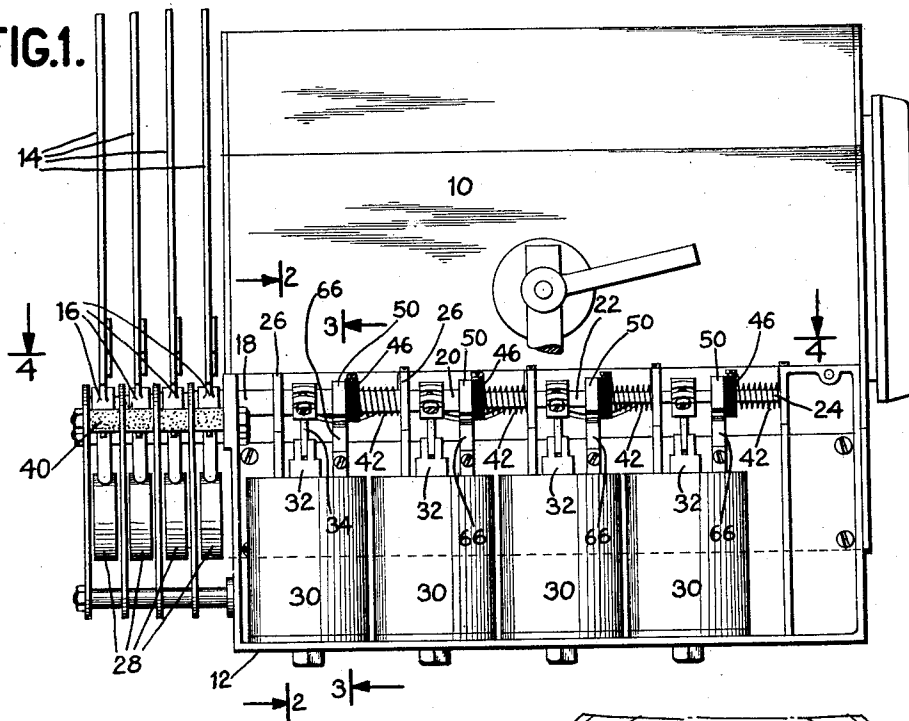
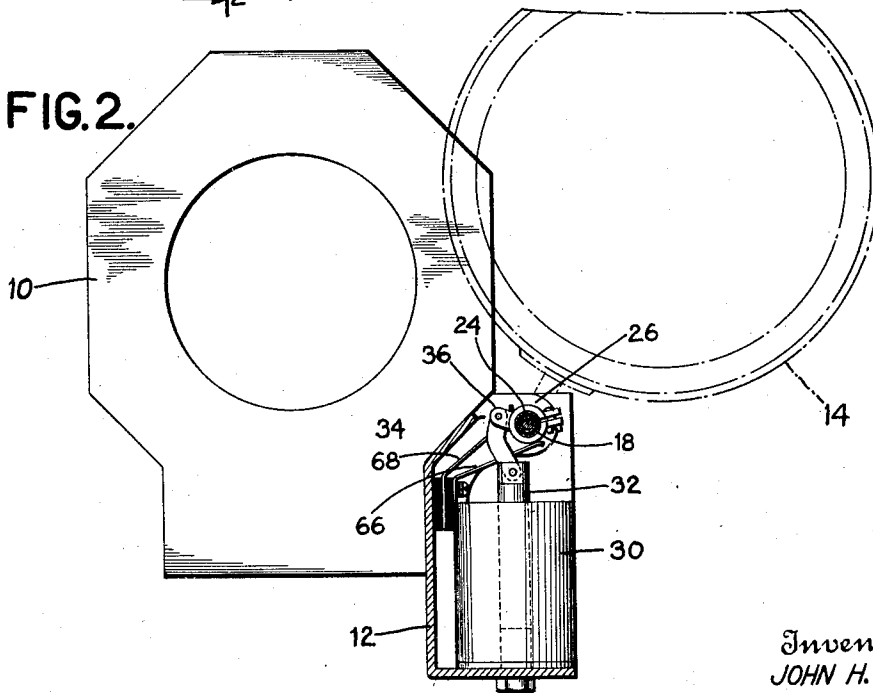

FIG. 2.



Inventor
JOHN H. KLIEGL.

By his Attorneys
Cooper, Kerr & Deukham

Sept. 6, 1932.

J. H. KLIEGL

1,875,814

COLOR SCREEN CONTROL

Filed April 27, 1929

2 Sheets-Sheet 2

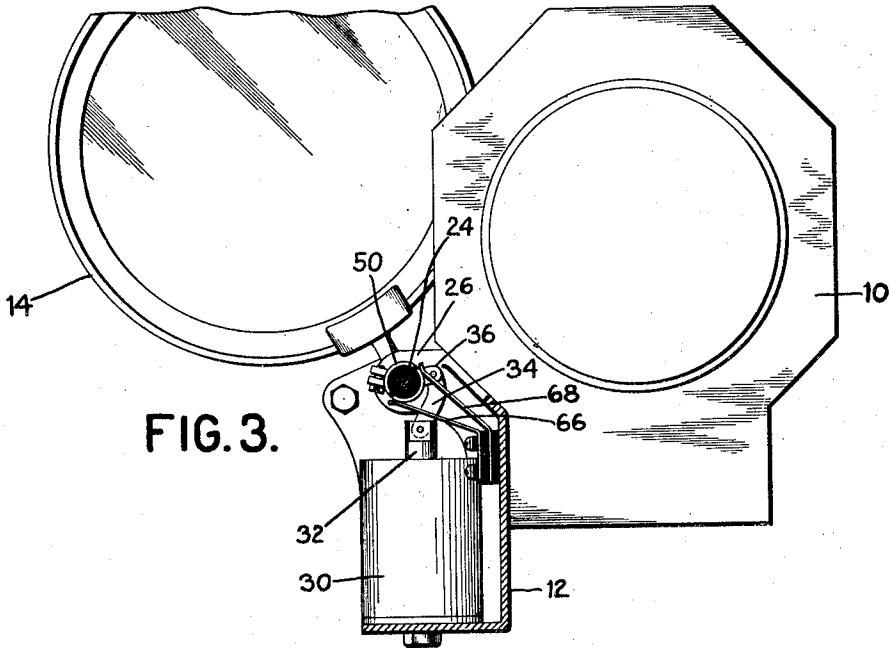

FIG. 3.

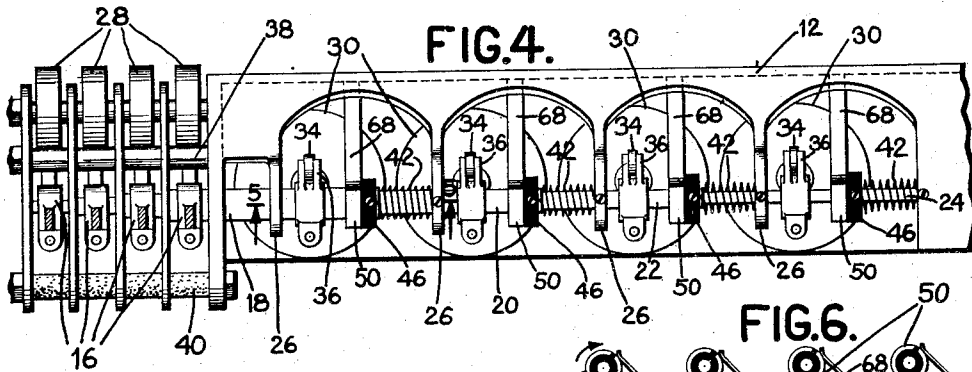

FIG. 4.

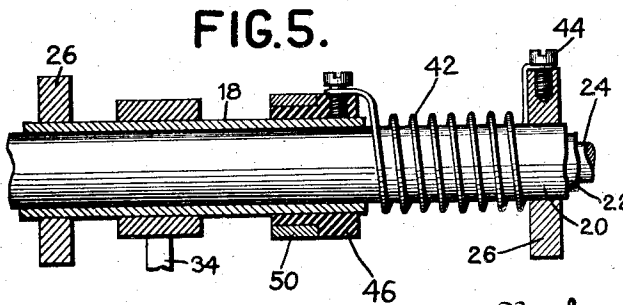

FIG. 5.

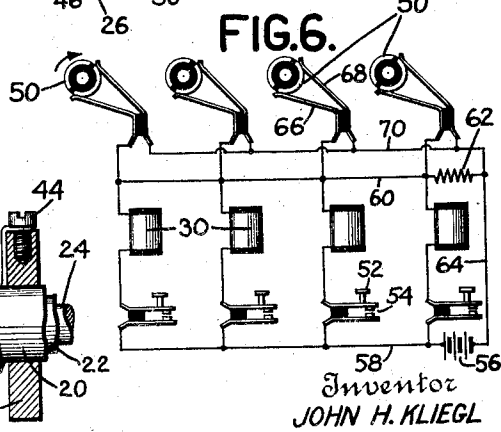

FIG. 6.

Inventor
JOHN H. KLIEGL

By his Attorneys
Cooper, Kerr & Dunham

UNITED STATES PATENT OFFICE

JOHN H. KLIEGL, OF NEW YORK, N. Y., ASSIGNOR TO KLIEGL BROS. UNIVERSAL ELECTRIC STAGE LIGHTING CO., INC., OF NEW YORK, N. Y., A CORPORATION OF NEW YORK

COLOR SCREEN CONTROL

Application filed April 27, 1929. Serial No. 358,540.

This invention pertains to spot lights of the kind used in theatres, and is devoted particularly to the apparatus and method for controlling color screens used in connection with such lights. The invention is an improvement on the invention described in my Patent No. 1,679,361, issued August 7, 1928, which discloses electro-magnetic mechanism by which an operator at a distance may manipulate the screens.

Broadly, the control mechanism comprises a solenoid, which when energized throws a screen to operative position and holds it there against the resistance of a spring, until the magnet is deenergized, whereupon the spring will return the screen to normal inoperative position.

In order to prevent too rapid movements of the screens and undue slamming of the screens against their stops, it has been necessary to restrict the power of the solenoids and to use an arrangement of balanced springs, which on the one hand helped the magnet to start the screen in motion, and on the other hand helped to retard the screen during the final stage of its travel. Such arrangements work well when the springs are properly adjusted and when the torque of the solenoid is always the same. However, it often happens, due to conditions on the supply line, dirt on contacts, etc., that the magnet does not act normally and trouble results. If the magnet is so designed as to have ample power when the voltage is low it will have so much power when the voltage is normal that violent action of the screws results.

The object of the present invention is to provide a magnetic control apparatus which will have ample power under any line conditions, which will not slam the screens under any conditions, and which does not require the use of carefully adjusted springs.

Further and other objects and advantages will appear from the specification and drawings which by way of illustration show what is now considered to be the preferred form of the invention.

In the drawings,
Fig. 1 is a side view of the spot light with

the electromagnetic control mechanism assembled thereon.

Fig. 2 is a cross-section on the line 2—2 of Fig. 1.

Fig. 3 is a cross section on the line 3—3 of Fig. 1.

Fig. 4 is a cross section on the line 4—4 of Fig. 1.

Fig. 5 is an enlarged detail view of the return spring control, on the line 5—5 of Fig. 4.

Fig. 6 is a circuit diagram.

In the drawings 10 is the spot light, to the side of which is bolted a box-like housing or frame 12 which supports the entire screen control mechanism. Four screens 14 are shown, each being secured by a clamp 16 to one of the concentric shafts 18, 20, 22, 24, which are supported for rotation in brackets 26 on the upper part of frame 12. Each screen is balanced about its axis by a weight 28 on the opposite side of its shaft.

Mounted on frame 12 are four solenoids 30, the plunger 32 of each solenoid being connected by a link 34 to a crank arm 36 fast on one of the shafts 18, 20, 22, 24, in such manner that when any solenoid 30 is energized its plunger 32 is drawn down, one shaft is rotated, and the screen 14 attached to the other end of that shaft is moved from its inoperative position as shown in Figs. 2 and 3 to its operative position in front of the spot light, and is held there so long as the magnet is energized. Padded rods 38 and 40 act as stops for the screens while in operative and inoperative position, respectively. When the magnet is deenergized the screen is returned to normal position by its spring 42. The spring arrangement will be understood from Fig. 5. One end of the torsion spring is attached by screw 44 to a bracket 26, while the free end of the spring is attached to a collar 46 fast on shaft 18. The spring tends to rotate shaft 18, and its attached screen 14, always toward inoperative position of the screen.

Collar 46 is of non-conducting material, and carries a contact ring 50, in two semi-circular sections, as shown in Fig. 6, the two sections being entirely out of electric contact with each other. With the above in

mind the operation of the magnetic control device may be understood from Fig. 6. When the operator depresses a key 52, closing contact 54, current flows from source 56 through line 58, contact 54, magnet 30, line 60, resistance 62, and line 64 back to source. But at the same time the current has another and easier path to follow, through spring blade 66, ring 50, spring blade 68, line 70 and line 64 to source. Most of the current follows the latter route, with the result that the magnet receives the full line voltage and is strongly energized, with the further result that the screen is positively started toward its operative position. However, as soon as the screen and its shaft begin to move, ring 50 is rotated so as to interpose an insulated gap between spring contacts 66 and 68, with the result that all the current must flow through resistance 62, and the torque of the solenoid is reduced accordingly with the result that the screen is delivered softly in inoperative position. When key 52 is released the screen is returned to normal position by its spring 42.

This invention has been found very satisfactory in practice. The screen is always started positively even with very low line voltage, and is always deposited softly in operative position even with high line voltage.

It is to be understood that the invention is not limited to the specific embodiment herein described but can be used in other ways without departure from its spirit as defined by the following claims.

I claim—

1. A color control apparatus for a spot light, comprising in combination, a color screen having normal and operative positions, a solenoid operatively connected to said screen, means for supplying current to said solenoid whereby said solenoid rotates said screen from normal to operative position, and means effective immediately after said rotation begins, for producing and maintaining a constant reduction in strength of said solenoid, whereby said screen is moved softly positively to operative position.

2. A color control apparatus for a spot light, comprising in combination, a color screen having normal and operative positions, a solenoid operatively connected to said screen, means for supplying current at comparatively high voltage to said solenoid whereby said solenoid rotates said screen from normal toward operative position, and means for automatically producing and maintaining a constant but reduced voltage through said solenoid after the rotation of the screen has started, for the purpose set forth.

3. A color control apparatus for a spot light, comprising in combination, a color screen having normal and operative positions, a solenoid operatively connected to said

screen, a resistance, a contact member, means for supplying current to said solenoid through said resistance and said contact member in parallel whereby said solenoid rotates said screen, and means effective while rotation is taking place for breaking the circuit through said contact member and thereby causing all the current to flow through said resistance, whereby said solenoid is supplied with a constant but weakened current, for the purpose set forth.

4. The method of operating a color screen for spotlights which consists in initiating a movement of the screen in front of the spotlight against a gradually increasing resistance with a substantially constant moving force considerably greater than the maximum resistance encountered, maintaining said force throughout a predetermined movement of the screen, and then suddenly changing said moving force to a substantially constant force having a strength less than the initial force and sufficient only to overcome the resistance at its maximum.

In testimony whereof I hereto affix my signature.

JOHN H. KLIEGL.

70

75

80

85

90

95

100

105

110

115

120

125

130

CERTIFICATE OF CORRECTION.

Patent No. 1,875,814.

September 6, 1932.

JOHN H. KLIEGL.

It is hereby certified that error appears in the printed specification of the above numbered patent requiring correction as follows: Page 1, line 96, for the misspelled word "non-conducting" read non-conducting; page 2, lines 22 and 23, for "inoperative" read operative; and that the said Letters Patent should be read with these corrections therein that the same may conform to the record of the case in the Patent Office.

Signed and sealed this 22nd day of November, A. D. 1932.

(Seal)

M. J. Moore,
Acting Commissioner of Patents.