



US012297990B2

(12) **United States Patent**
Lumassi et al.

(10) **Patent No.:** **US 12,297,990 B2**

(45) **Date of Patent:** **May 13, 2025**

(54) **LIGHT FIXTURE**

(56) **References Cited**

(71) Applicant: **CLAY PAKY S.R.L.**, Seriate (IT)

U.S. PATENT DOCUMENTS

(72) Inventors: **Alessandro Lumassi**, Seriate (IT); **Aris Quadri**, Seriate (IT)

6,352,358 B1 3/2002 Lieberman et al.
2011/0159549 A1* 6/2011 Oldham F21K 9/64
315/118

(73) Assignee: **CLAY PAKY S.R.L.**, Seriate (IT)

FOREIGN PATENT DOCUMENTS

(*) Notice: Subject to any disclaimer, the term of this patent is extended or adjusted under 35 U.S.C. 154(b) by 0 days.

EP 2982906 A1 2/2016
WO 2015106024 A1 7/2015
WO 2016193674 A1 12/2016

OTHER PUBLICATIONS

(21) Appl. No.: **18/640,162**

Italian Search Report in IT Application No. 202300008040 mailed Oct. 18, 2023, an English Translation attached hereto (6 pages).

(22) Filed: **Apr. 19, 2024**

* cited by examiner

(65) **Prior Publication Data**

Primary Examiner — Jason M Han

(74) *Attorney, Agent, or Firm* — Leason Ellis LLP

US 2024/0353091 A1 Oct. 24, 2024

(30) **Foreign Application Priority Data**

(57) **ABSTRACT**

Apr. 24, 2023 (IT) 102023000008040

A light fixture includes a head housing a source assembly configured to emit a light beam and a support assembly configured to support the head. The light fixture further includes a temperature control assembly configured to control the temperature inside the head and/or the support assembly. The temperature control assembly includes at least one temperature control device; at least one first temperature sensor; and at least one first temperature control module housed in the head and/or in the support assembly and regulated by the temperature control device on the basis of data coming from the at least one first temperature sensor. The at least one first temperature control module is provided with a heating element and a ventilating element which are independently controllable by the temperature control device.

(51) **Int. Cl.**
F21V 29/67 (2015.01)
F21V 21/30 (2006.01)

(52) **U.S. Cl.**
CPC **F21V 29/677** (2015.01); **F21V 21/30** (2013.01)

(58) **Field of Classification Search**
CPC F21V 21/30
See application file for complete search history.

9 Claims, 2 Drawing Sheets

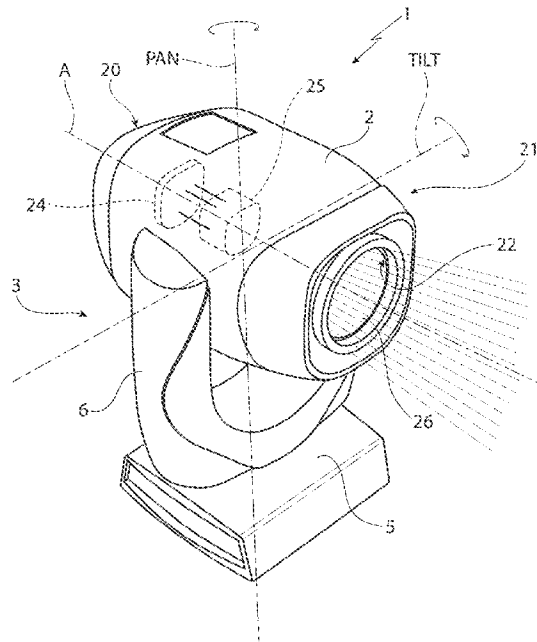

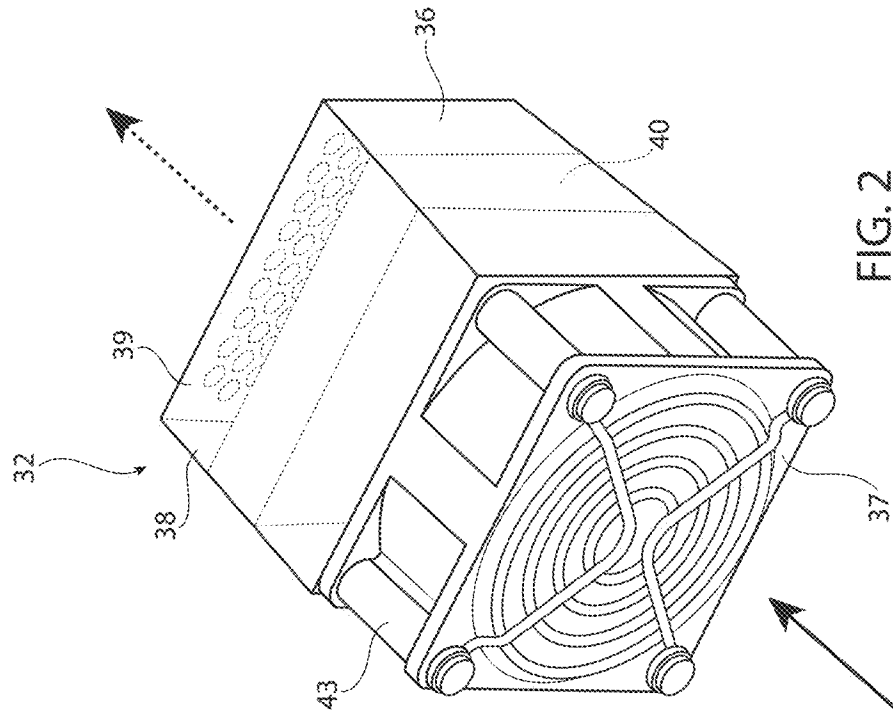
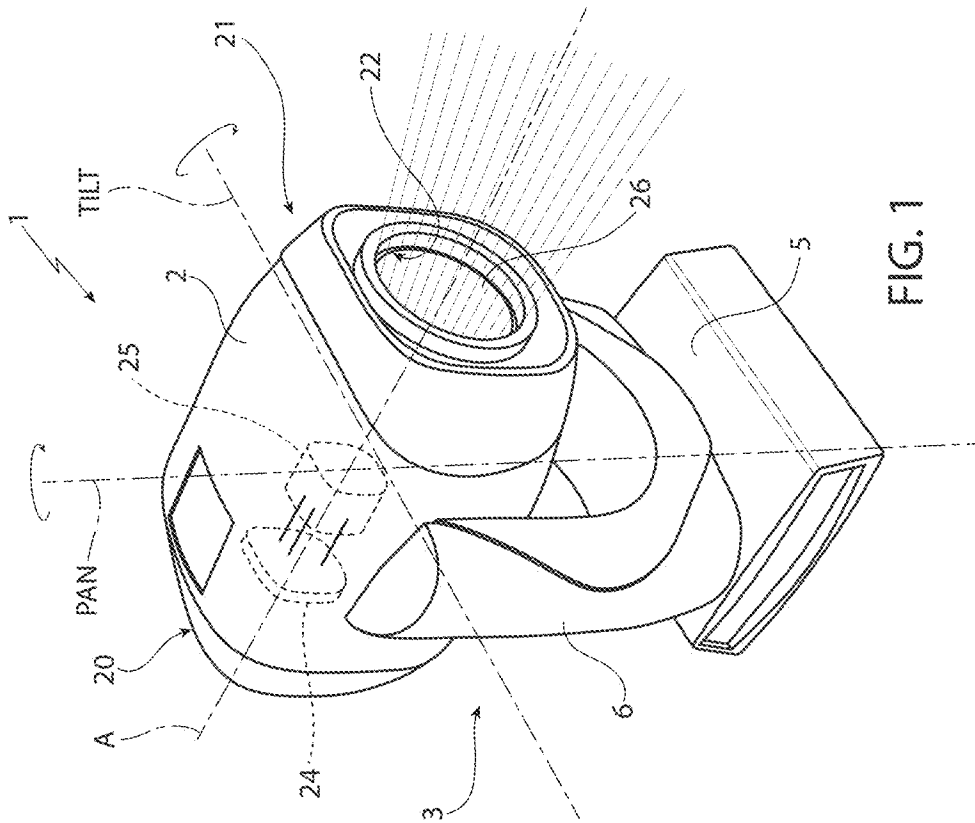

FIG. 1

FIG. 2

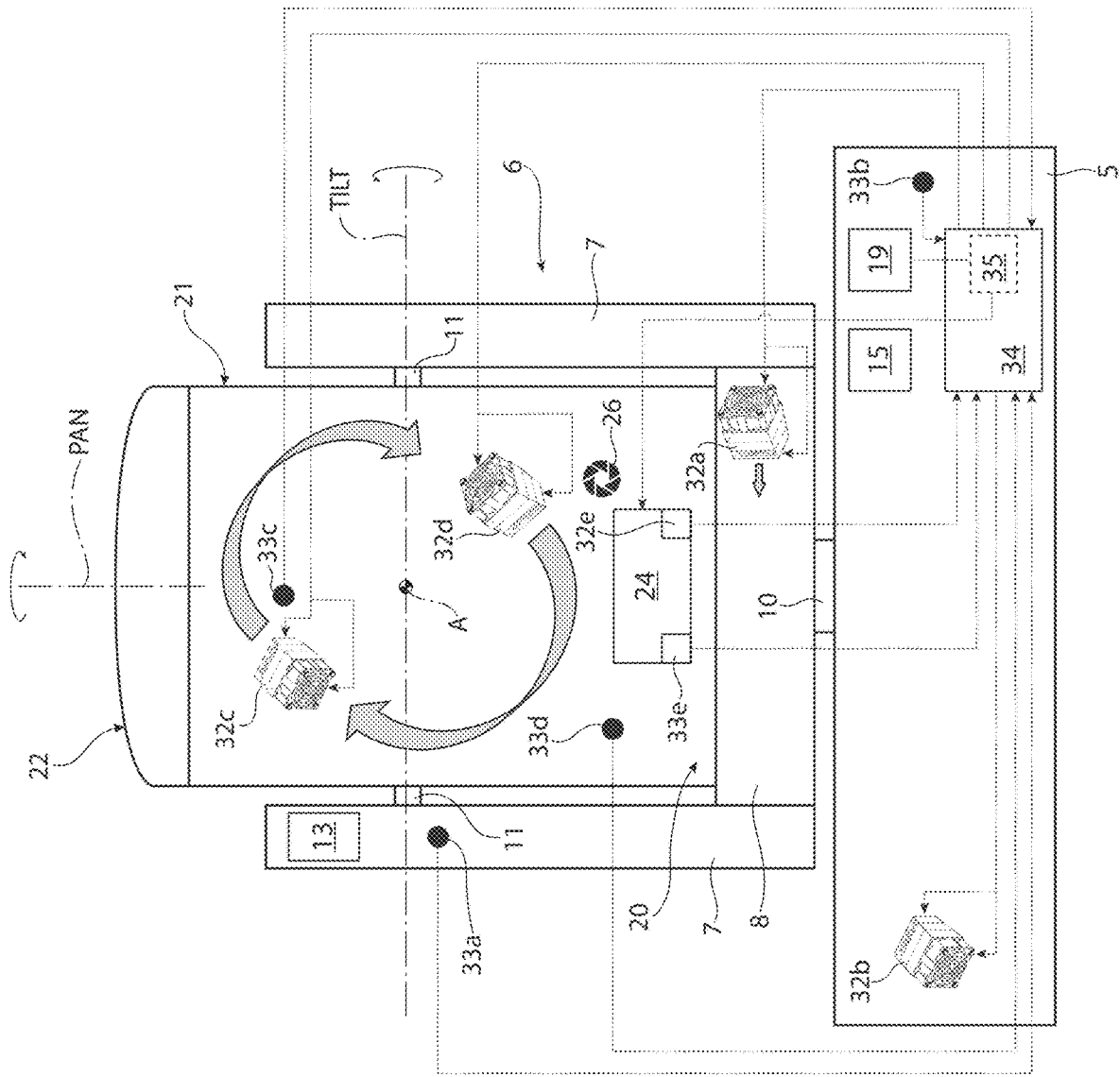

FIG. 3

1

LIGHT FIXTURE

CROSS-REFERENCE TO RELATED APPLICATIONS

This patent application claims priority from Italian patent application no. 102023000008040 filed on Apr. 24, 2023, the entire disclosure of which is incorporated herein by reference.

TECHNICAL FIELD

The present invention concerns a light fixture.

In particular, the present invention concerns a light fixture configured to generate one or more light beams in scenic contexts (for example to light stages) and/or in architectural contexts (for example to light skyscrapers or monuments).

BACKGROUND

Light fixtures of this type are normally provided with ventilation systems dedicated to temperature control. Said systems, however, are dedicated only to removal of the excess heat generated by the light sources used or by the components (electronic and/or mechanical) inside the light fixture.

The use of light fixtures in outdoor environments exposes the light fixtures not only to thermal stress due to high temperatures (up to +45° C.), but also to thermal stress due to excessively low temperatures (down to -40° C.), which can compromise the correct operation of some components (mechanical and/or electronic) of the light fixture or cause condensation inside the light fixture which can affect the functionality of the optical elements.

SUMMARY

An object of the present invention is therefore to provide a light fixture which is simple and inexpensive to produce and which is reliable in any external thermal condition.

In accordance with said objects the present invention concerns a light fixture comprising:

a head housing a source assembly configured to emit a light beam;

a support assembly configured to support the head;

a temperature control assembly configured to control the temperature inside the head and/or of the support assembly; the temperature control assembly comprising:

at least one temperature control device;

at least one first temperature sensor; and

at least one first temperature control module housed in the head and/or in the support assembly and regulated by the temperature control device on the basis of the data coming from the at least one first temperature sensor; the at least one first temperature control module being provided with a heating element and a ventilating element which are independently controllable by the temperature control device.

BRIEF DESCRIPTION OF THE DRAWINGS

Further characteristics and advantages of the present invention will appear clear from the following description of a non-limiting embodiment example thereof, with reference to the figures of the attached drawings, in which:

2

FIG. 1 is a perspective schematic view, with parts removed for clarity and internal parts shown by broken lines, of a light fixture according to the present invention;

FIG. 2 is a perspective view, with parts removed for clarity, of a detail of the light fixture according to the present invention;

FIG. 3 is a planar schematic view, with parts removed for clarity and parts shown schematically, of the light fixture according to the present invention.

DESCRIPTION OF EMBODIMENTS

In FIG. 1 the reference number 1 indicates a light fixture comprising a casing 2, which here and below will be generically referred to as head 2, and a support assembly 3 configured to support the head 2.

The support assembly 3 is configured so as to allow the head 2 to rotate about two orthogonal axes, commonly defined PAN and TILT. Therefore, in the non-limiting example described and illustrated here, the head 2 is a movable head.

In particular, the support assembly 3 comprises a base 5 and a yoke 6.

The yoke 6 is coupled to the base 5 in such a manner as to rotate about the axis PAN and is provided with two arms 7 and a bridge portion 8 that connects the two arms 7.

The yoke 6 supports the head 2 in a rotating manner about the axis TILT. In particular, the arms 7 of the yoke 6 are coupled to the head 2.

With reference to the schematic representation of FIG. 3, the rotation of the yoke 6 about the axis PAN occurs by means of a pin 10 (in this example vertical), which is integral with the yoke 6 and extends from the bridge portion 8 of the yoke 6 until it penetrates the base 5.

The rotation of the head 2 around the axis TILT occurs by means of pins 11 arranged on opposite sides of the head 2 and aligned along the axis TILT (in this example horizontal). The pins 11 are integral with the head 2 and penetrate into the respective arms 7 of the yoke 6.

To generate the rotations described above, a first motor 13 is provided (schematically shown in FIG. 3) housed in one of the arms 7 of the yoke 6 and configured to move one of the pins 11 and a second motor 15 (also schematically shown in FIG. 3), housed in the base 5 and configured to move the pin 10.

Operation of the motors 15 and 13 is regulated by a control device, which comprises at least one electronic control module 19 housed in the base 5 (schematically shown in FIG. 3).

The control device can comprise further control electronics housed in the head 2 and/or in the yoke 6 and is preferably remote-controlled by means of communications with DMX protocol.

With reference to FIG. 1 and FIG. 3, the head 2 extends along a longitudinal axis A. In FIG. 1 the axis A is arranged crosswise to the axis PAN, while in FIG. 3 the head 2 is in a different position from the one illustrated in FIG. 1 and the axis A is arranged parallel to the axis PAN.

The head 2 has a closed end 20 and an open end 21, which is arranged opposite the closed end 20 along the axis A and is provided with at least one projection opening 22 (which can be seen more clearly in FIG. 1). In the non-limiting example described and illustrated here, the projection opening 22 has a substantially circular section.

Inside the head 2 at least one source assembly 24 is housed (schematically shown in FIG. 3) configured to generate at least one light beam and at least one beam process-

ing element **25** arranged so as to intercept the light beam generated by the source assembly **24**. A final optical element **26** (preferably a lens) is housed in the projection opening **22**.

The light fixture **1** according to the present invention also comprises a temperature control assembly, which preferably comprises a plurality of temperature control modules **32**, a plurality of temperature sensors **33** and a temperature control device **34**.

Preferably, the temperature control assembly also comprises a fan **26** configured to move the air inside the head **2**.

The fan **26** is preferably arranged at the closed end **20** of the head **2** near the source assembly **24**.

The temperature control modules **32** are distributed in the light fixture **1** and in particular are housed in the base **5** and/or in the yoke **6** and/or in the head **2**.

With reference to FIG. 2, each temperature control module **32** comprises a heating element **36** and a ventilating element **37**.

The heating element **36** is configured to emit heat and comprises a casing **38**, provided with at least a drilled (or at least partly drilled) wall **39**, and a heater assembly **40** (schematically shown in FIG. 2) housed in the casing **38**.

The heater assembly **40** can be produced using different technologies. For example, the heating element **36** can comprise a PTC heater assembly based on ceramic semiconductors in aluminium housings.

Alternatively, the heater assembly **40** can comprise plates made with heating cables or Joule effect resistive heating systems, wire-wound resistors, plate resistors, armoured resistors, etc.

The ventilating element **37** comprises at least a fan (not clearly visible in FIG. 2) housed in a housing body **43**. The fan of the ventilating element **37** is configured to suck in and/or expel any air heated by the heating element **36**.

The heating element **36** and the ventilating element **37** are arranged alongside each other. Preferably the heating element **36** and the ventilating element **37** are coupled to each other.

The heating element **36** and the ventilating element **37** of each temperature control module **32** can be independently controlled by the temperature control device **34**.

The temperature control device **34** is therefore able to activate and regulate independently, for each temperature control module **32**, the heating element **36** and the ventilating element **37**.

In this way, as will be seen in detail further on, the temperature control modules **32** can be used not only in heating mode (i.e. with heating element **36** and ventilating element **37** active simultaneously), but also in cooling mode (i.e. with only the ventilating element **37** active and the heating element **36** not active).

The temperature control device **34** is configured to selectively regulate each temperature control module **32** on the basis of temperature values detected in the light fixture **1** by means of at least one temperature sensor **33**.

In the non-limiting example described and illustrated here, the temperature control assembly comprises at least one temperature control module **32a** housed in the yoke **6**, at least one temperature control module **32b** housed in the base **5** and at least one temperature control module **32c** housed in the head **2**.

Preferably, the temperature control assembly also comprises a further temperature control module **32d** housed in the head **2** and a heater device **32e** housed in the head **2** and preferably in the source assembly **24**.

The temperature control module **32a** is housed in the yoke **6** preferably in a junction portion between one of the arms **7** and the bridge portion **8** of the yoke **6**.

More preferably, the temperature control module **32a** is arranged in the junction between the arm **7** that does not house the motor **13** and the bridge portion **8** of the yoke **6**.

The temperature control module **32b** is arranged in the base **5**.

The temperature control modules **32c** and **32d** are preferably arranged in the head **2** in substantially diametrically opposite positions so as to create, in use, a forced ventilation that follows a substantially circular ventilation path. Preferably, the temperature control modules **32c** and **32d** are arranged respectively in a portion proximal to the open end **21** of the head **2** and in a portion proximal to the source assembly **24** and, preferably, also to the fan **26**.

In particular, the temperature control modules **32c** and **32d** are arranged in the head **2** in the portions just defined, but in areas proximal to the walls of the head **2** so as not to intercept the light beam generated by the source assembly **24** (said aspect is not clearly visible in the planar representation of FIG. 3).

The temperature control assembly further comprises at least one temperature sensor **33a** housed in the yoke **6**, at least one temperature sensor **33b** housed in the base **5** and at least one temperature sensor **33c** housed in the head **2**.

Preferably, the temperature control assembly also comprises two further temperature sensors **33d** **33e** housed in the head **2**.

The temperature sensor **33a** is preferably arranged in the arm **7** in which the motor **13** is housed.

The temperature sensor **33b** is housed in the base **5** near the electronic control module **19**.

The temperature sensor **33c** is arranged at the open end **21** of the head **2**, preferably in a substantially median portion (i.e. on a median plane passing through the axis **A**), but preferably near the walls of the head **2** in order not to intercept the light beam generated by the source assembly **24**.

The temperature sensor **33d** is arranged at the closed end **20** of the head **2**, near the source assembly **24** and ventilation path generated by the temperature control modules **32c** and **32d**.

The temperature sensor **33e** is arranged in the source assembly **24**.

The temperature sensors **33a** **33b** **33c** **33d** are preferably NTC probes. The temperature sensor **33e** is preferably a thermocouple arranged in contact with a portion of the source assembly **24**. For example, if the source assembly **24** comprises a laser source and at least one phosphor disc, the temperature sensor **33e** is preferably arranged in contact with the motor responsible for the movement of the phosphor disc.

In use, the temperature control device **34** receives in input the data coming from at least one temperature sensor **33** (in the example described here from at least one of the temperature sensors **33a** **33b** **33c** **33d** **33e**) and on the basis of said data, selectively regulates at least one temperature control module **32** (in the example described here at least one of the temperature control modules **32a** **32b** **32c** **32d**) and possibly the heater **32e**.

Furthermore, the temperature control device **34** comprises a safety module **35**, which sends a consent signal enabling the source assembly **24** and/or the electronic control module **19** on the basis of the temperatures detected by at least one of the temperature sensors **33b** **33d** **33e**.

5

In particular, if the temperature detected by both the sensors **33d** and **33e** is higher than 0° C., the safety module **35** sends a consent signal enabling the source assembly **24** and/or if the temperature detected by the sensor **33b** is higher than 0° C. the safety module **35** sends a consent signal enabling the electronic control module **19**. Without the consent signal, the source assembly **24** and the electronic control module **19** cannot be used.

In other words, the source assembly **24** and the electronic control module **19** can be activated only when the temperature detected inside the head **2** and inside the base **5** is higher than 0° C.

In further detail, the temperature control device **34** is configured to monitor the temperature detected by the temperature sensors **33a 33b 33c 33d 33e**.

If at least one of the temperature sensors **33c, 33d** and **33e** housed in the head **2** detects a temperature lower than 0° C., the temperature control device **34** activates the heating element **36** and the ventilating element **37** of the control modules **32c, 32d** in the head **2** and, preferably, also activates the heater device **32e**.

If at least one of the temperature sensors **33c, 33d** and **33e** detects a temperature higher than 5° C., the temperature control device **34** deactivates the heating element **36** of the control modules **32d** and **32c** and the heater device **32e**, leaving active the ventilating element **37** of the control modules **32d** and **32c**.

If the temperature sensor **33e** integrated in the source assembly **24** detects a temperature higher than 20° C., the fan **26** and any other ventilation systems provided in the head **2** are activated by the temperature control device **34**.

If the temperature detected by the temperature sensor **33c** is higher than 20° C., the heating element **36** of the control module **32c** is deactivated, leaving only the ventilating element **37** active.

In this way, in the head **2** an optimal temperature is guaranteed for operation of the source assembly **24** and the components arranged inside the head **2** in all operating and external temperature conditions.

The temperature control device **34** is furthermore configured to activate the heating element **36** and the ventilating element **37** of the temperature control module **32a** when the temperature value detected by the temperature sensor **33a** in the yoke **6** is lower than 0° C.

The temperature in the yoke **6** is therefore kept at optimal levels for operation of the motor **13** and the components housed in the yoke **6** (e.g. transmissions, etc.).

Lastly, the temperature control device **34** is configured to activate the heating element **36** and the ventilating element **37** of the temperature control module **32b** when the temperature value detected by the temperature sensor **33b** in the base **5** is lower than 10° C. The heating element **36** of the temperature control module **32b** is therefore maintained active until the temperature detected by the temperature sensor **33b** in the base **5** reaches 20° C. When the temperature of 20° C. is reached, the ventilating element **37** of the temperature control module **32b** is maintained active and the heating element **36** of the temperature control module **32b** is switched off.

In this way the temperature in the base **5** is kept under control in all external temperature conditions.

Advantageously, the light fixture according to the present invention is able to maintain a controlled temperature in all ambient temperature conditions from -40° C. to +45° C.

Moreover, the presence of temperature control modules **32** having a ventilating element **37** and a heating element **36** that can be independently controlled means that different

6

temperature conditions can be addressed. When the circulation of hot air is necessary, the temperature control modules **32** are used in heating and ventilation mode. When, on the other hand, it is sufficient to facilitate the air circulation without any need for heating, the temperature control modules **32** are used only in ventilation mode, helping to convey the air as required by the situation.

Substantially, the temperature control modules **32** are configured to generate a forced air circulation which can be selectively heated as required.

Lastly it is evident that modifications and variations can be made to the light fixture described here without departing from the scope of the attached claims.

The invention claimed is:

1. A light fixture comprising:

a head housing a source assembly configured to emit a light beam;

a support assembly configured to support the head;

a temperature control assembly configured to control the temperature inside the head and/or the support assembly; the temperature control assembly comprising:

at least one temperature control device;

at least one first temperature sensor; and

at least one first temperature control module housed in the head and/or in the support assembly and regulated by the temperature control device on the basis of data coming from the at least one first temperature sensor; the at least one first temperature control module being provided with a heating element and a ventilating element which are independently controllable by the temperature control device;

wherein the temperature control device is configured to activate the heating element and the ventilating element of the at least one first temperature control module when the temperature value detected by the at least one first temperature sensor is lower than a first threshold value and to deactivate the heating element while leaving the ventilating element active when the temperature value detected by the at least one first temperature sensor is higher than a second threshold value; the second threshold value being higher than the first threshold value;

wherein the temperature control assembly comprises two first control modules and at least one first temperature sensor housed in the head; the two first control modules being arranged in substantially diametrically opposite positions so as to create, in use, a forced ventilation following a substantially circular ventilation path.

2. The light fixture according to claim 1, wherein the first two temperature control modules are respectively arranged in a portion proximal to a projection opening of the head and in a portion proximal to the source assembly.

3. The light fixture according to claim 1, wherein the temperature control device is configured to activate the heating element and the ventilating element of the first temperature control modules when the temperature value detected by the at least one first temperature sensor housed in the head is lower than the first threshold value and to deactivate the heating element while leaving the ventilating element active when the temperature value detected by the at least one first temperature sensor in the head is higher than the second threshold value.

4. The light fixture according to claim 1, wherein the temperature control device comprises a safety module, which is configured to send a consent signal to enable the source assembly based on temperatures detected by the at least one first temperature sensor housed in the head.

7

5. The light fixture according to claim 1, wherein the support assembly is configured to move the head.

6. A light fixture comprising:
a head housing a source assembly configured to emit a light beam;
a support assembly configured to support the head;
a temperature control assembly configured to control the temperature inside the head and/or the support assembly; the temperature control assembly comprising:
at least one temperature control device;
at least one first temperature sensor; and
at least one first temperature control module housed in the head and/or in the support assembly and regulated by the temperature control device on the basis of data coming from the at least one first temperature sensor; the at least one first temperature control module being provided with a heating element and a ventilating element which are independently controllable by the temperature control device;

wherein the support assembly is configured to move the head;

8

wherein the support assembly is configured to allow the head to rotate about a first axis and a second axis, orthogonal to the first axis; the support assembly comprising a base and a yoke; the yoke being coupled to the base in a manner rotatable about the first axis and supporting the head in a manner rotatable about the second axis.

7. The light fixture according to claim 6, wherein the temperature control assembly comprises at least a second temperature sensor and at least a second temperature control module both housed in the base.

8. The light fixture according to claim 6, wherein the temperature control assembly comprises at least a third temperature sensor and at least a third temperature control module both housed in the yoke.

9. The light fixture according to claim 8, wherein the yoke is provided with two arms, connected to the head, and a bridge portion connecting the two arms; the third control module being arranged in a junction portion between one of the arms and the bridge portion of the yoke.

* * * * *