



US011428384B2

(12) **United States Patent**  
**Jurik et al.**

(10) **Patent No.:** **US 11,428,384 B2**

(45) **Date of Patent:** **Aug. 30, 2022**

(54) **DUV CONTROL OF LUMINAIRE BEAM COLOR**

(71) Applicant: **Robe Lighting s.r.o.**, Roznov pod Radhostem (CZ)

(72) Inventors: **Pavel Jurik**, Prostedni Becva (CZ); **Jan Zamecnik**, Hodslavice (CZ); **Jan Vilem**, Vsetin (CZ); **Josef Valchar**, Prostedni Becva (CZ)

(73) Assignee: **Robe Lighting s.r.o.**, Roznov pod Radhostem (CZ)

(\* ) Notice: Subject to any disclaimer, the term of this patent is extended or adjusted under 35 U.S.C. 154(b) by 0 days.

(21) Appl. No.: **17/576,045**

(22) Filed: **Jan. 14, 2022**

(65) **Prior Publication Data**

US 2022/0228727 A1 Jul. 21, 2022

**Related U.S. Application Data**

(60) Provisional application No. 63/138,171, filed on Jan. 15, 2021.

(51) **Int. Cl.**  
**F21V 9/40** (2018.01)  
**F21V 9/08** (2018.01)  
(Continued)

(52) **U.S. Cl.**  
CPC ..... **F21V 9/40** (2018.02); **F21V 9/08** (2013.01); **F21V 14/08** (2013.01); **F21S 10/007** (2013.01);  
(Continued)

(58) **Field of Classification Search**  
CPC ..... F21V 9/08; F21V 9/20; F21V 9/40; F21V 14/08; F21V 14/085; F21W 2131/406; F21S 10/007; F21S 10/02; F21S 10/026  
See application file for complete search history.

(56) **References Cited**

U.S. PATENT DOCUMENTS

4,602,321 A \* 7/1986 Bornhorst ..... F21V 9/40  
362/268  
5,969,868 A \* 10/1999 Bornhorst ..... G02B 26/008  
359/590

(Continued)

OTHER PUBLICATIONS

European Extended Search Report; Application No. 22151694.1; dated Jun. 3, 2022; 8 pages.

*Primary Examiner* — Colin J Cattanach

(74) *Attorney, Agent, or Firm* — Conley Rose, P. C.; Brooks W Taylor

(57) **ABSTRACT**

A luminaire includes a white light LED light source emitting a light beam that that is filtered by first and second color filters. An optical device modifies the filtered light beam. A control system receives a commanded value for the optical device and responds by causing the optical device to move based on the commanded value; determining a Duv change in the light beam caused by the optical device; determining positions for the color filters based on the Duv change, a current correlated color temperature (CCT) isotherm value, and a current Duv value; and moving the color filters to their determined positions. The control system may alternatively receive a command with a Duv value and respond by determining color filters positions based on the received Duv value and a current CCT isotherm value; and moving the color filters to their determined positions.

**20 Claims, 7 Drawing Sheets**

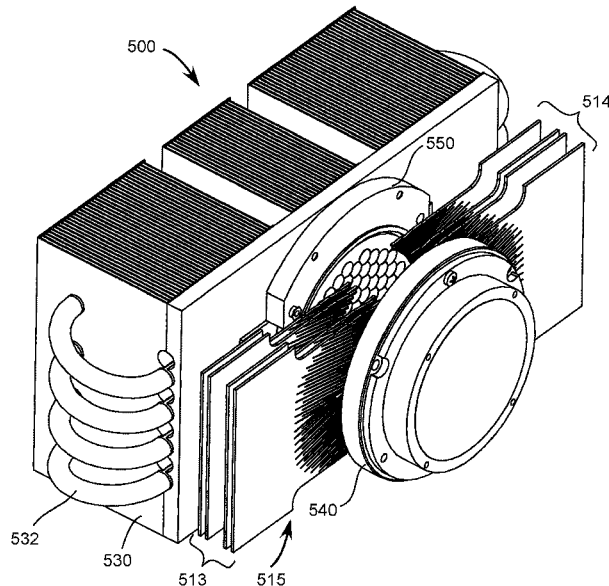

- (51) **Int. Cl.**  
*F21V 14/08* (2006.01)  
*F21V 9/20* (2018.01)  
*F21W 131/406* (2006.01)  
*F21S 10/00* (2006.01)  
*F21S 10/02* (2006.01)
- (52) **U.S. Cl.**  
CPC ..... *F21S 10/02* (2013.01); *F21S 10/026*  
(2013.01); *F21V 9/20* (2018.02); *F21V 14/085*  
(2013.01); *F21W 2131/406* (2013.01)

(56) **References Cited**

U.S. PATENT DOCUMENTS

2001/0055209 A1\* 12/2001 Dedoro ..... F21S 10/007  
362/268  
2002/0159262 A1\* 10/2002 Romano ..... F21V 7/24  
362/426  
2009/0231854 A1\* 9/2009 Jurik ..... F21S 10/02  
362/293  
2018/0045390 A1\* 2/2018 Campetella ..... F21S 10/007  
2018/0368217 A1\* 12/2018 Toft ..... G02B 5/22  
2019/0024860 A1\* 1/2019 Belliveau ..... F21V 9/40  
2019/0078742 A1\* 3/2019 Dalsgaard ..... F21V 14/08  
2019/0219249 A1\* 7/2019 David ..... F21V 14/08  
2021/0356095 A1\* 11/2021 Gadegaard ..... H05B 45/22

\* cited by examiner

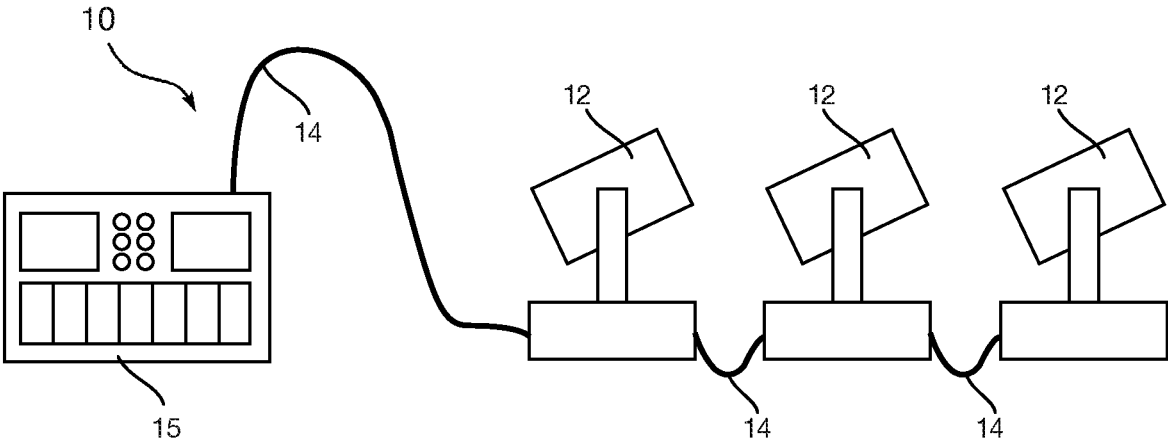

FIG. 1

20

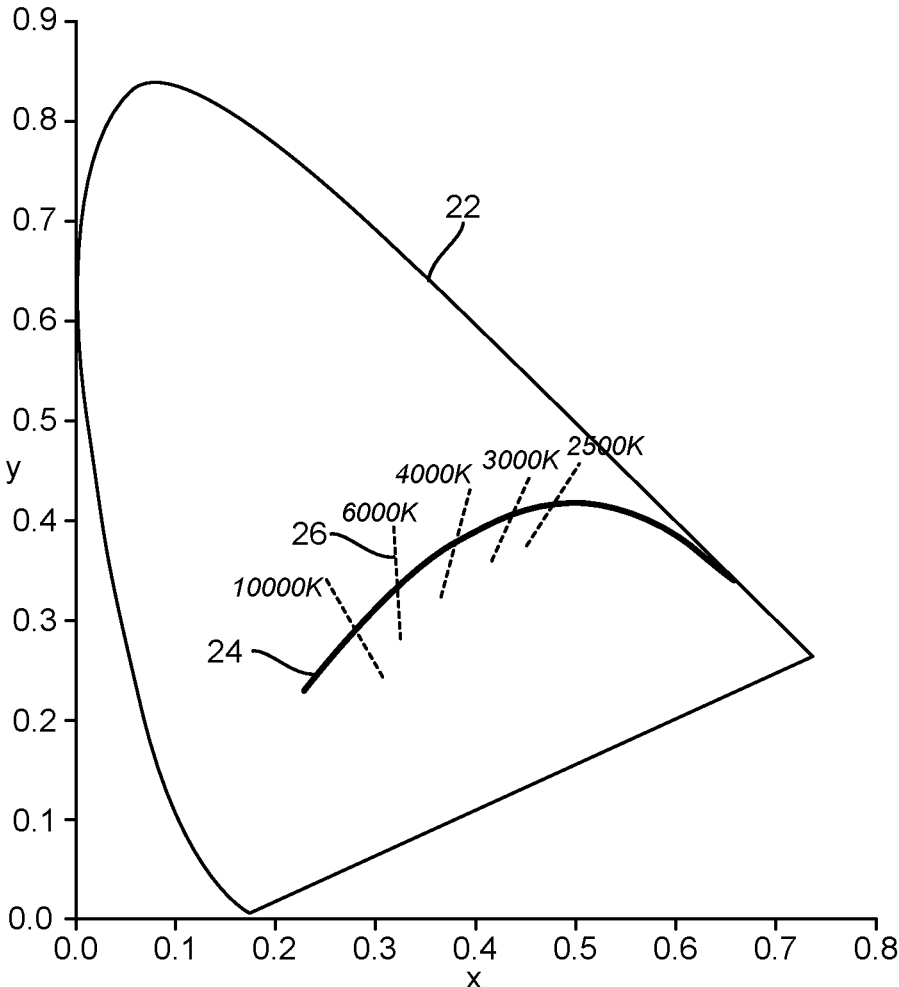

FIG. 2

30

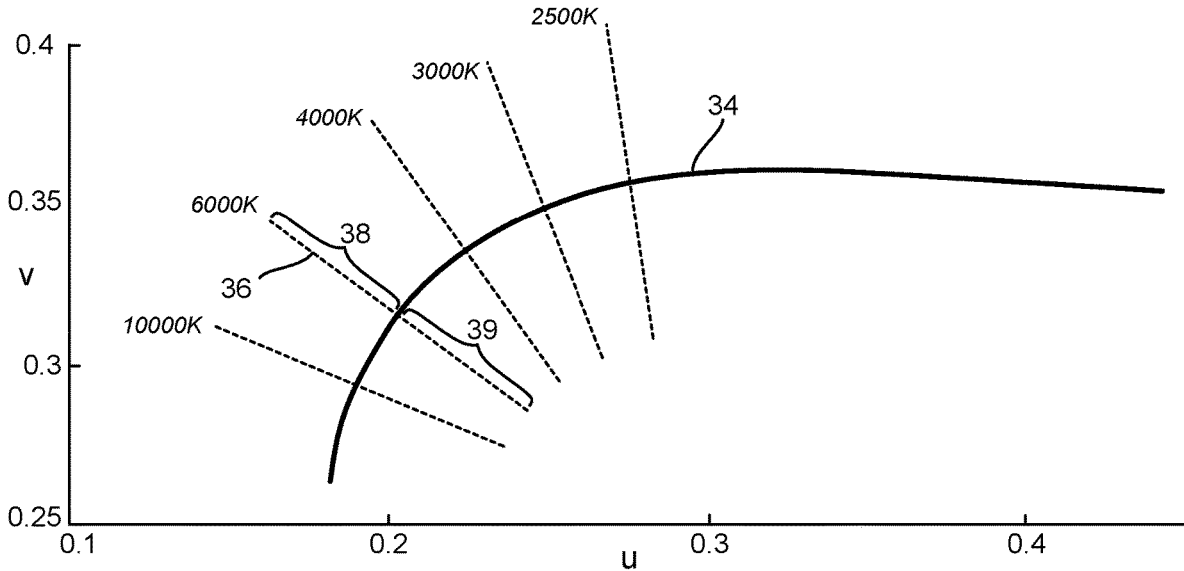

FIG. 3

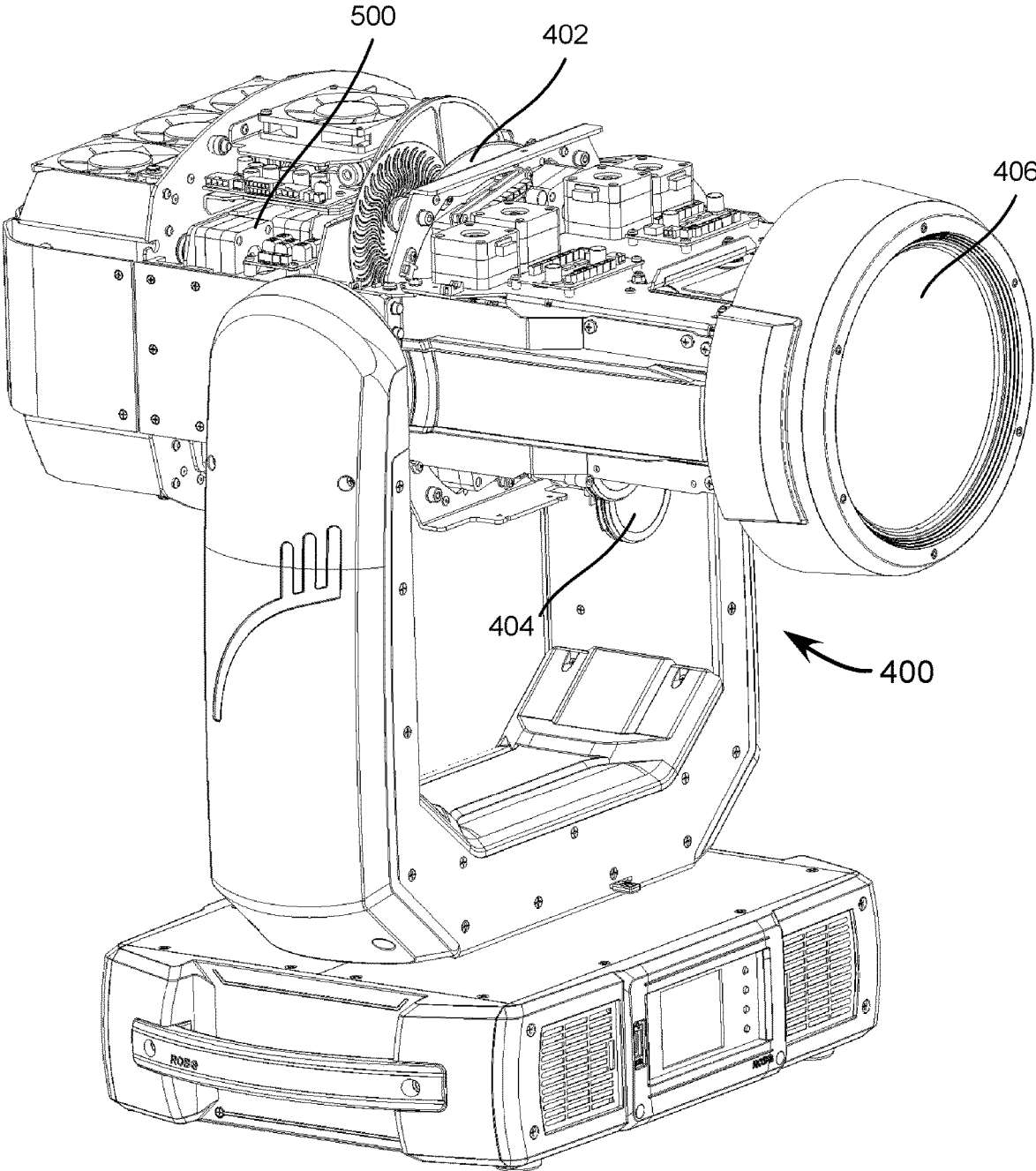

FIG. 4

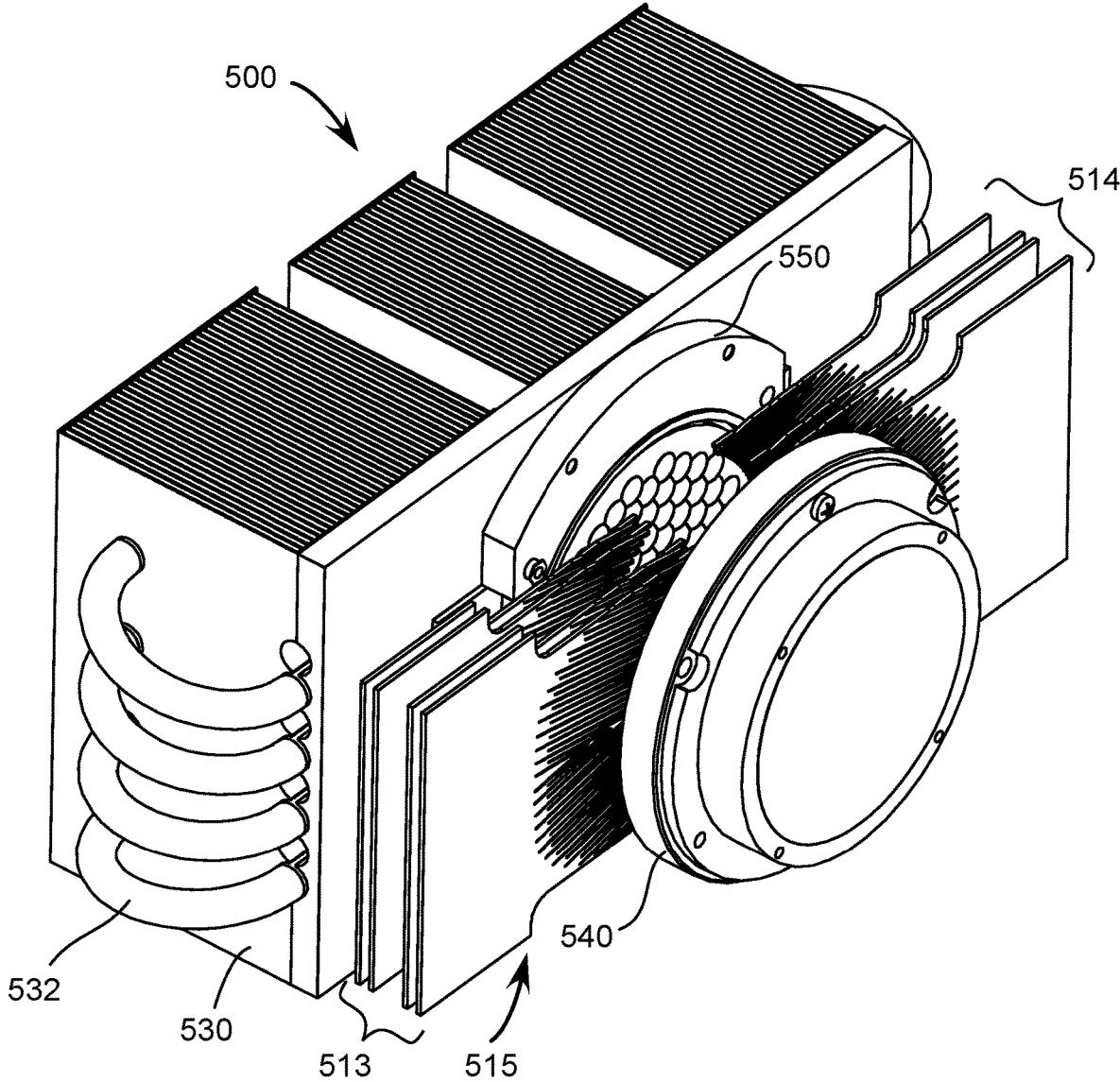

FIG. 5

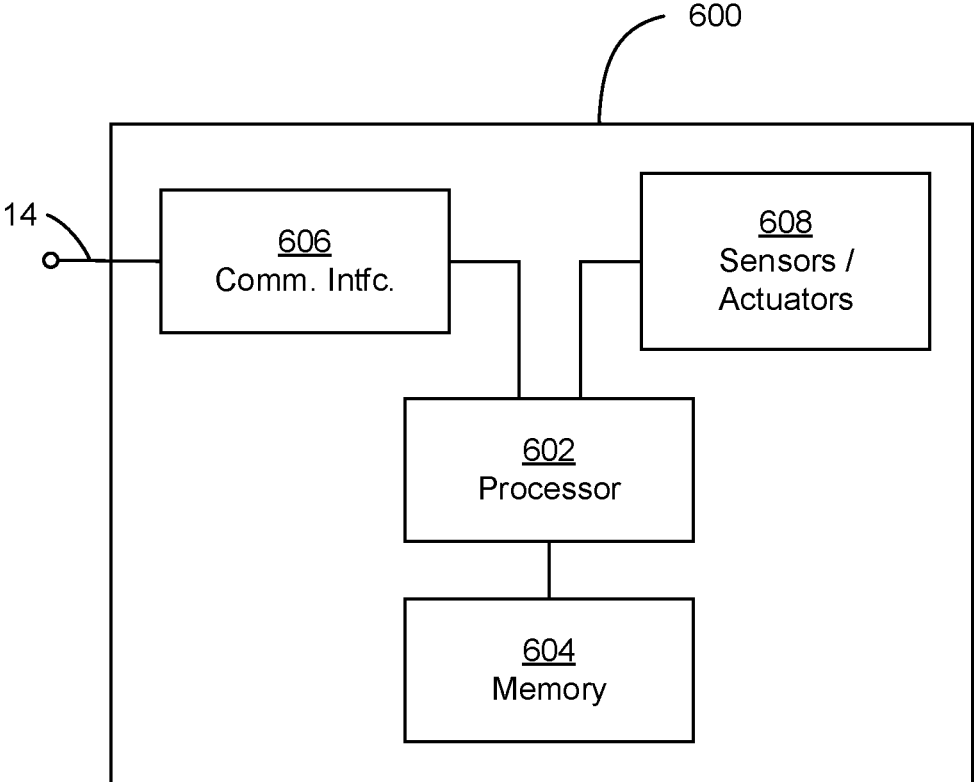

FIG. 6

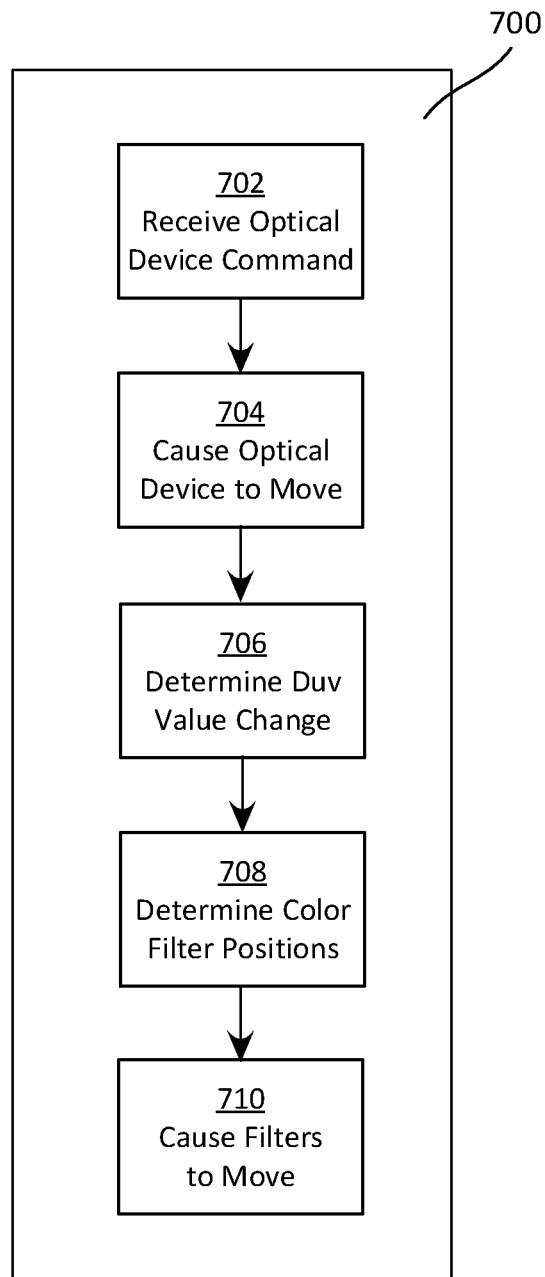

FIGURE 7

1

## DUV CONTROL OF LUMINAIRE BEAM COLOR

### CROSS-REFERENCE TO RELATED APPLICATIONS

This application claims priority to U.S. Provisional Application No. 63/138,171 filed Jan. 15, 2021 by Pavel Jurik, et al. entitled, "Duv Control of Luminaire Beam Color", which is incorporated by reference herein as if reproduced in its entirety.

### TECHNICAL FIELD OF THE DISCLOSURE

The disclosure generally relates to luminaires, and more specifically to a color control system for providing adjustment of the Duv parameter of light emitted from luminaires, in particular white light-emitting diode (LED) based luminaires.

### BACKGROUND

Luminaires utilizing white light LED light sources have become well known in the entertainment and architectural lighting markets. Such products are commonly used in theatres, television studios, concerts, theme parks, night clubs, and other venues. These LED luminaires may be static or automated luminaires. A typical static LED luminaire will commonly provide control over the intensity of the luminaire. A typical automated luminaire will commonly provide control over the intensity and color of the light output of the luminaire.

### SUMMARY

In a first embodiment, a luminaire includes an LED light source, first and second color filters, an optical device, and a control system. The LED light source is configured to emit a white light beam. The first and second color filters are configured to receive the white light beam and emit a colored light beam. The optical device is configured to receive the colored light beam, modify the colored light beam, and emit a modified light beam. The control system is electrically coupled to the first and second color filters and the optical device and is configured to receive via a data link an optical device command that includes a setting value for the optical device. The control system is also configured to, in response to the optical device command, cause the optical device to move based on the setting value; determine a Duv value change that is caused by the optical device, based on the setting value; determine first and second positions, respectively, of the first and second color filters based on the Duv value change, a current correlated color temperature (CCT) value of a CCT isotherm, and a current Duv value; and cause the first and second color filters to move, respectively, to the first and second positions.

In a second embodiment, a luminaire includes an LED light source, first and second color filters, and a control system. The LED light source is configured to emit a white light beam. The first and second color filters are configured to receive the white light beam and emit a colored light beam. The control system is electrically coupled to the first and second color filters and is configured to receive via a data link a Duv command that includes a received Duv value for the colored light beam. The control system is also configured to, in response to the Duv command, determine first and second positions, respectively, of the first and

2

second color filters based on the received Duv value and a correlated color temperature (CCT) value of a CCT isotherm; and cause the first and second color filters to move, respectively, to the first and second positions.

5 In a third embodiment, a method of controlling a color of a light beam emitted by a luminaire includes receiving an optical device command, which includes a setting value for an optical device that is configured to modify a light beam emitted by the luminaire. The method also includes causing the optical device to move based on the setting value and determining, based on the setting value, a Duv value change in a color of the light beam emitted by the luminaire, where the Duv value change is caused by the optical device based on the setting value. The method further includes determining first and second positions, respectively, of first and second color filters of the luminaire, based on the Duv value change, a CCT value of a CCT isotherm, and a current Duv value. The method also includes changing the color of the light beam by causing the first and second color filters, respectively, to move to the first and second positions in the light beam.

### BRIEF DESCRIPTION OF THE DRAWINGS

25 For a more complete understanding of the present disclosure and the advantages thereof, reference is now made to the following description taken in conjunction with the accompanying drawings in which like reference numerals indicate like features and wherein:

30 FIG. 1 presents a schematic view of an automated luminaire system according to the disclosure;

FIG. 2 presents a standard Commission Internationale de l'Éclairage (CIE) 1931 xy chromaticity diagram;

35 FIG. 3 presents a central portion of a standard CIE 1960 uv chromaticity diagram;

FIG. 4 presents a luminaire according to the disclosure;

FIG. 5 presents a more detailed view of the LED light engine of FIG. 4;

40 FIG. 6 presents a block diagram of a control system for an automated luminaire according to the disclosure; and

FIG. 7 presents a flow chart of a process for color control of an automated luminaire according to the disclosure.

### DETAILED DESCRIPTION

Preferred embodiments are illustrated in the figures, like numerals being used to refer to like and corresponding parts of the various drawings.

50 Some LED luminaires include an LED based light source designed to collate and direct light through the optical systems installed in the luminaire. The LED light sources along with associated collimating and directing optics are referred to herein as a light engine. Some LED light engines include LEDs of a single color, such as white, herein referred to as a white light LED engine. Other LED light engines include LEDs of a range of colors, where the brightness of at least some LEDs or groups of LEDs of a common color are controllable to provide additive mixing of the LED output colors. Although the embodiment described and illustrated in the disclosure uses an LED based light engine, in other embodiments the light source may use discharge lamps, plasma lamps, incandescent lamps or other suitable light sources. A color control system according to the disclosure is not dependent on nor limited by a specific light source.

65 A typical white light LED engine contains a plurality of white LEDs and associated optical systems to combine,

collimate, and direct a light beam from the LED engine through the remainder of the optical system of the luminaire. The remainder of the optical system may include elements such as gobos, prisms, frost filters, zoom lenses and other optical devices designed to receive the light beam from the LED engine, modify the light beam, and emit a modified light beam.

The term 'white light' encompasses a range of actual colors. Light referred to as 'white' may vary from a very cold bluish white (e.g., as produced by an arc lamp) through warm reddish whites (e.g., as produced by a candle). These colors are referred to as 'white,' but may be differentiated by a characteristic referred to as 'color temperature.' The higher the value of color temperature, the more blue the 'white' light appears.

The colors of light that are accepted by the eye as white of a given color temperature may be referred to as a CCT value. 'White' beams with a common value of CCT will appear as the same color temperature to the human eye, but with a tint towards either magenta or green. The amount of tint is described by a value referred to as 'Duv.' Remotely controlled automated luminaires may have tunable color systems that enable them to emit white light beams having CCT values that are under the control of an operator of such luminaires.

Luminaires with differing types of light sources or from different manufacturers may produce light beams that have common CCT values, but that do not look the same to a human eye because the light beams differ in their Duv parameters. The color control system according to the disclosure enables a user to match the Duv of a luminaire to other luminaires that are being used in the same lighting system without changing the CCT values of the luminaires. Such matching does not require the operator to adjust manually the positions of individual color filters or the brightness of colored LED emitters.

FIG. 1 presents a schematic view of an automated luminaire system **10** according to the disclosure. The automated luminaire system **10** includes a plurality of automated luminaires **12** according to the disclosure. Each automated luminaire **12** includes a light source and parameter control devices such as color changing devices, light modulation devices, and pan and/or tilt systems to control an orientation of a head of the automated luminaire **12**. Mechanical drive systems to control parameters of the automated luminaire **12** include motors or other suitable actuators coupled to control electronics, as described in more detail with reference to FIG. 6. Such actuators may include stepper motors to provide the movement for internal optical systems. Examples of such optical systems include gobo wheels, effects wheels, and color mixing systems, as well as prism, iris, shutter, and lens movement.

In addition to being connected to mains power either directly or through a power distribution system, each automated luminaire **12** is connected in series or in parallel by a data link **14** to one or more control desks **15**. Upon actuation by an operator, the control desk **15** sends control signals (such as commands) via the data link **14**, where the control signals are received by one or more of the automated luminaires **12**. The one or more of the automated luminaires **12** that receive the control signals may respond by changing one or more of the parameters of the receiving automated luminaires **12**. The control signals are sent by the control desk **15** to the automated luminaires **12** via data link **14** using DMX-512, Art-Net, ACN (Architecture for Control Networks), Streaming ACN, or other suitable communication protocol.

In some embodiments, control of the automated luminaires **12** is limited to control of an intensity of the light source. Such embodiments are often referred to as static luminaires. The static luminaire is still remotely controllable, but the user has no control over the position of the unit. In other embodiments, the automated luminaire **12** includes a motorized head or mirror to control a direction of an emitted light beam. Such embodiments are often referred to as moving luminaires. The present disclosure applies equally to moving or static luminaires.

FIG. 2 presents a standard CIE 1931 xy chromaticity diagram **20**. The diagram **20** shows a boundary **22**, which encompasses all colors viewable by the human eye. The boundary **22** indicates the range of colors from a saturated blue in the bottom left corner, through a saturated red in the bottom right corner, and a saturated green at the top left peak of the curve. Line **24** is referred to as the 'Planckian locus' (or the 'black body' line) and indicates the color emitted by an incandescent black body at various temperatures. The Planckian locus **24** is limited to colors that are considered as 'white.' Some example color temperatures (or temperatures of the incandescent black body) are labeled on the diagram **20**. For example, line **26** is the line for a color temperature of 6000 Kelvin (K). Other dashed lines in the diagram **20** represent other color temperatures.

The example color temperatures are represented in the diagram **20** as lines, rather than as single points because, while the actual white point for a given color temperature lies exactly on the Planckian locus **24**, the human vision system is flexible and perceives as the same white of a given color temperature lightly saturated colors that lie close to the Planckian locus **24**, but not exactly on it. The value of color temperature of light on the dashed lines that are accepted by the eye as white of a given color temperature may be referred to as the Correlated Color Temperature (CCT) value. 'White' beams with a common value of CCT will appear as the same color temperature to the human eye, but with a tint towards either magenta (for points below the Planckian locus **24**) or green (for points above the Planckian locus **24**). The dashed lines in FIG. 2 such as line **26** are referred to as 'CCT isotherms.' Every point along a CCT isotherm has the same value of CCT, but differs in its amount of tint, which difference is shown as a distance from the Planckian locus.

FIG. 3 presents a central portion **30** of a standard CIE 1960 uv chromaticity diagram. The full CIE 1960 uv color space describes the same range of colors as the 1931 xy chromaticity diagram **20** shown in FIG. 2 (i.e., all colors visible to the human eye), however only the portion **30** of the CIE 1960 uv color space around the Planckian locus is shown in FIG. 3. The axes in the CIE 1960 uv color space are adjusted via a linear projective transform such that CCT isotherms (e.g., CCT isotherm **36** for CCT value of 6000K) are now shown as normal to the Planckian locus **34**. Because the CCT isotherms are normal to the Planckian locus **34** in the uv chromaticity diagram of FIG. 3, we can use the CCT value and CCT isotherms as orthogonal coordinates to uniquely refer to any white point. The two coordinates are referred to as CCT and Duv. Duv is sometimes referred to as 'Delta uv', 'Delta (u,v)', '+/-green', or 'plus-or-minus green'. For consistency this disclosure will use Duv throughout to refer to this parameter but it should be understood that the parameter could equally be labeled or called '+/-green' or any other synonym. CCT is the color temperature white position along the Planckian locus **34**, such as the intersection point of the CCT isotherm **36** with the Planckian locus **34**, while Duv is the distance an actual

5

white color point is from the Planckian locus **34** along a given CCT isotherm. As a convention, points that are above the Planckian locus **34** (e.g., in the range **38**) have positive Duv values, while points that are below the Planckian locus **34** (e.g., in the range **39**) have negative Duv values. Points on a CCT isotherm that have a more positive value of Duv are perceived as having a larger amount of green tint, while those that have a more negative value of Duv are perceived as having a larger amount of pink or magenta tint.

FIG. 4 presents a luminaire **400** according to the disclosure. Luminaire **400** includes an LED light engine **500** emitting a colored light beam and optical devices such as gobos **402**, prism and frost systems **404**, and zoom lens system **406**. Other embodiments may include more or fewer optical devices. Such optical devices receive the colored light beam emitted by the LED light engine **500** and emit a modified light beam.

FIG. 5 presents a more detailed view of the LED light engine **500** of FIG. 4. An LED light source **550** comprising an array of white light LED emitters is mechanically and thermally coupled to a heat sink **530** that includes light pipes **532**. Diverging white light beams emitted by the emitters of the LED light source **550** pass through dichroic filters **513** and **514**, which comprise a color mixing module **515**. A control system **600** according to the disclosure (described in more detail with reference to FIG. 6) is electrically coupled to and controls the positions and settings of the LED light engine **500**, the color mixing module **515**, and the optical devices such as gobos **402**, prism and frost systems **404**, and zoom lens system **406**.

While the embodiment in FIG. 5 includes a plurality of LED emitters, other embodiments may include a single LED emitter. Still other embodiments may include a single or multiple arc sources or other suitable emitter(s) of light beam(s). While the LED array of the LED light source **550** emits diverging light beams, in other embodiments a light source according to the disclosure may emit one or more parallel or converging light beams.

Dichroic filters **513** and **514** comprise like-colored pairs of filters (one each from dichroic filters **513** and **514**) each comprising a dichroic coated transparent substrate. Each like-colored pair is configured to be independently positioned with the dichroic coating completely out of the light beams, fully covering the light beams, or in intermediate positions partially or completely covering one or more (i.e., a subset) of the light beams.

An integration module **540** receives the light beams emitted by the array of LEDs of the LED light source **550** and passing through the dichroic filters **513** and **514**. All the light beams may still be white, if all of the dichroic filters **513** and **514** are withdrawn from the beams. All the light beams may be fully colored, if one or more pairs of the dichroic filters **513** and **514** are fully covering the beams. If one or more of the dichroic filters **513** and **514** are partially covering the light beams, various subsets of the light beams may be white, fully colored, and/or partially colored. The integration module **540** integrates brightness variations and homogenization of colors of the received light beams, to produce a single light beam with a smoother illumination and color profile across the integrated light beam. By independently and coordinately positioning the dichroic filters **513** and **514**, a user may accurately control the color of the filtered light beams and produce an integrated light beam of a desired color temperature.

The integrated light beam emitted by the integration module **540** is the colored light beam emitted by the LED light engine **500**. In some configurations, the dichroic filters

6

**513** and **514** are withdrawn from the light beam and the colored light beam emitted by the LED light engine **500** is a white light beam comprising the white light beams emitted by the emitters of the LED light source **550** and integrated by the integration module **540**.

In other embodiments, the white light beams emitted by the emitters of the LED light source **550** passes through the integration module **540** and then through the color mixing module **515**. In such embodiments, the light beam emitting from the color mixing module **515** is the colored light beam emitted by the LED light engine **500**.

The color mixing module **515** comprises four pairs of dichroic filters, one pair each in cyan, yellow, magenta, and color temperature orange (CTO). Although the pairs of dichroic filters of the color mixing module **515** are moved linearly across the light beams, other embodiments may include other numbers of dichroic filters that are moved into and out of the light beams in any suitable manner. Color mixing modules according to the disclosure may include filters configured as linear flags, rotary discs, wheels, or arcuate flags. In some embodiments color mixing modules according to the disclosure may include three dichroic filters configured as discs with patterned dichroic coatings that may be rotated across the light beams.

Dichroic filters **513** and **514** each comprises a rectangular, clear substrate whose width (short dimension) completely spans a combined height of the light beams and whose length (long dimension) is longer than the combined width of the light beams. The substrate is coated with dichroic material in a pattern comprising a first portion at a first end of the substrate, the first portion being of a size to fully cover the light beam. The first portion abuts a second portion that comprises a plurality of fingers of dichroic material whose width diminishes toward a second end of the substrate. In this way, the dichroic material of the dichroic filters **513** and **514** fully filter the light beams at the first end, and provide diminishing filtration as they are removed linearly from the light beams.

In other embodiments, the dichroic filter material may be etched, cut, or similarly configured in other patterns on a clear substrate, to form regions of differing amounts of dichroic filter interspersed with regions of clear substrate. In still other embodiments, both the dichroic filter and underlying substrate may be cut into a pattern with varying density, such as tapered fingers, such that regions of differing amount of dichroic filter are interspersed with areas where both dichroic filter and substrate have been removed.

In further embodiments, a clear substrate may be coated with a varying dichroic material, such that different regions of the coated substrate filter the light beams to different colors. In still other embodiments, differing portions of a substrate may be coated with different dichroic materials, where the portions are of sufficient size to fully cover the light beam and each portion produces a different consistent color across the entirety of the light beam. In yet other embodiments, two or more wheels may include removable individual fully coated dichroic filters that each fully covers the light beams.

The color mixing module **515** comprises four pairs of graduated color filters that are adjustable by the user to control a saturation of each color. The filters of the color mixing module **515** comprise cyan, yellow, magenta (CYM), and CTO. The four filters are arranged such that the white light beams from the LED light source **550** pass in series through any filters or portions of filters that are positioned in the beam, such that the resultant light color after passing through the color mixing module **515** is a

subtractive combination of all four filters from the original white light of the LED emitters of the LED light source 550. In other embodiments, a CTB filter may be used in place of a CTO filter. In still other embodiments, the CTO filter is not present and only cyan, magenta, and yellow filters are used.

Each of the cyan, magenta, yellow, and CTO filters affects a characteristic range of wavelengths (or wavelength range) of the light passing through it. As the filter is moved into the white light beams from the LED light source 550, the filter removes progressively more of the light in the wavelength range from those light beams that pass through the filter. Examples of such wavelength ranges in some embodiments are band pass from 380 nanometers (nm) to 555 nm for a cyan filter, band reject from 450 nm to 620 nm for a magenta filter, band pass from 510 nm to 780 nm for a yellow filter, and transmissivity above 600 nm that decreases from 600 nm to 400 nm for a CTO filter. In other embodiments, filters having other characteristic wavelength ranges may be used.

Each of the optical devices such as the gobos 402, the prism and frost systems 404, and the zoom lens system 406 may have an effect on the color of the light beam passing through them. They may change either or both of the CCT and the Duv of the light beam. Users of color controllable luminaires are accustomed to adjusting the CCT of the light beam using the color mixing module 515, in fact, there may be a dedicated pale-yellow filter called CTO as part of the color mixing module 515 that is specifically designed for this purpose. However, adjusting the Duv of the light beam color may be more difficult. Because the Planckian locus follows a curve, the adjustment needed to change Duv without changing CCT may vary depending upon the value of CCT. At some CCT values, changing the Duv may require adjustment of only the magenta filter, while at other CCT values changing the Duv may require adjustment of all three subtractive filters to compensate for a change in Duv without changing the CCT value. The control system 600 reduces that difficulty for the user by providing a single parameter control of the Duv value while maintaining a CCT value.

During design and manufacture of a luminaire according to the disclosure (or at another stage, such as final calibration during quality control, regular maintenance, repair, or refurbishment), the color system of the luminaire may be measured and characterized so as to map out a range of CCT and Duv values the color system can provide. Then, through use of a lookup table or other computational tool, the control system 600 is configured to convert a current Duv value and a received CCT value in a CCT command received via the data link 14 into filter positions of the color mixing module 515 to produce a color specified by the current Duv value and the received CCT value or to convert a current CCT value and a received Duv value in a Duv command received via the data link 14 into filter positions to produce a color specified by the current CCT value and the received Duv value.

In some embodiments, the CCT value is received on a CCT control channel of the data link 14 and the Duv command value is received on a Duv control channel of the data link 14. In other embodiments, a command value is received via the data link 14 along with information identifying the command value as a CCT value or a Duv value.

For example, the color mixing module 515 may be adjusted by use of the CCT control channel to provide the 6000K CCT indicated by CCT isotherm 36 in FIG. 3. Then, as the user adjusts the Duv control channel, the control system 600 automatically recalculates and re-positions any necessary ones of the dichroic filters 513 and 514 so that the light beam color moves along the 6000K CCT isotherm 36.

The user may thus adjust the Duv value into the positive range 38 or the negative range 39, as desired, without accidentally also changing the CCT of the emitted light beam. In some embodiments, the Duv parameter adjustment system according to the disclosure allows the user to control Duv within a range of +/-0.02.

Tables 1 and 2 presents lookup tables for converting Duv command values on the Duv control channel into filter motor positions for CCT values 6000K and 3200K, respectively, on the CCT control channel. The filter motor positions correspond to positions of the dichroic filters 513 and 514 in the LED light beams from the LED light source 550. Similar tables may be provided for other frequently used values of CCT (e.g., 2500K, 4000K, and 10,000K). Other Duv command values may be converted into filter motor positions by interpolating between values in adjacent rows of a lookup table (e.g., a Duv command value of 0.005 for 6000K may be calculated from values in the 6000K tables for Duv command values of 0.003 and 0.01). Similarly, for other CCT values received on the CCT control channel, Duv command values may be converted into filter motor positions by interpolation (linear or nonlinear) between values in adjacent lookup tables (e.g., Duv command values for 3000K may be calculated from values in the tables for 3200K and 2500K).

TABLE 1

CCT	Duv	Cyan	Magenta	Yellow	CTO
6000K	0.02	5%	1.6%	6%	9.0%
6000K	0.01	5%	2.2%	6%	9.5%
6000K	0.003	5%	3.1%	6%	9.8%
6000K	0.001	5%	3.7%	6%	9.9%
6000K	0.00	5%	4%	6%	10%
6000K	-0.001	5%	4.3%	6%	10.1%
6000K	-0.003	5%	4.9%	6%	10.2%
6000K	-0.01	5%	5.8%	6%	10.5%
6000K	-0.02	5%	6.5%	6%	11.0%

TABLE 2

CCT	Duv	Cyan	Magenta	Yellow	CTO
3200K	0.02	8%	1.0%	9.2%	88%
3200K	0.01	8%	1.2%	8.6%	90%
3200K	0.003	8%	1.8%	8.2%	91%
3200K	0.001	8%	1.9%	8.1%	91.5%
3200K	0.00	8%	2.0%	8.0%	92%
3200K	-0.001	8%	2.1%	7.9%	92.5%
3200K	-0.003	8%	2.2%	7.8%	93%
3200K	-0.01	8%	2.8%	7.4%	94%
3200K	-0.02	8%	3.0%	6.8%	96%

This facility enables the user to match the Duv of a luminaire according to the disclosure to other luminaires being used in the same lighting system. Luminaires with differing types of light sources, or even those from other manufacturers that use the same type of light source, may produce light beams of the same color temperature or CCT value, but still not look the same to a human eye or a camera because the light beams differ in their Duv parameters. The Duv parameter adjustment system according to the disclosure enables the user to match light beams visually to the eye and/or camera without altering the CCT values of the luminaires. Such matching may be done without having to manually adjust individual CYM/CTO color parameters of the color mixing system. Light beams from luminaires according to the disclosure may be more closely matched with other white light sources.

In some embodiments, the Duv parameter adjustment system according to the disclosure provides automatic Duv correction as optical devices are inserted/removed into/from the beam or as they are adjusted. Optical systems for which automatic Duv correction may be made may include the gobos **402**, the prism and frost systems **404**, and the zoom lens system **406**, as well as prism, iris, shutter, neutral density (ND) dimming and lens movement devices. In some embodiments, the LED light source **550** is an optical device for which automatic Duv correction may be made, as the color temperature of the LEDs may change as they are dimmed electronically.

In one example, the adjustment by a user of a focal length of the zoom lens system **406** from a narrow beam setting to a wide beam setting may alter the Duv value of the emitted light beam. In such embodiments, the Duv parameter adjustment system according to the disclosure is configured to compensate for this emitted beam Duv change in an active, dynamic manner. The control system **600** in such embodiments may be either controlling, monitoring, or otherwise determining a setting of the zoom lens system **406** (e.g., positions and movement of the motors that control the zoom lens focal length). As a focal length of the zoom lens system **406** changes (whether by independent control or by operation of the control system **600**), the control system **600**, without requiring user intervention, determines the new setting and uses the motor position information to automatically adjust the color mixing system to correct the Duv continuously to maintain a commanded Duv value. In other embodiments, where inserting a glass gobo, frost filter, or prism alters the Duv value of the emitted light beam, or where the beam is dimmed by electronic dimming or an ND filter, the control system **600** is configured to compensate automatically for such changes and maintain the commanded Duv value.

Table 3 presents a lookup table for changes in Duv value produced by zoom lens focal length changes, either alone or in combination with other optical devices, in a sample luminaire where the CCT/Duv tables were created with the zoom lens set to a wide zoom angle. In the example luminaire, as the zoom angle is adjusted from narrow to wide, the Duv value change varies from 0.0005 to 0.0. In other luminaires, the Duv value may change over a larger range, for example, 0.0 to 0.01. The Duv value change from Table 3 can be applied to the commanded Duv value and a resulting adjusted Duv value be combined with a CCT value using the lookup tables and interpolation techniques described above.

TABLE 3

	Zoom Narrow	Zoom Mid	Zoom Wide
No effects inserted	0.0005	0.0003	0.0
Gobo inserted	0.0002	0.0000	-0.0017
Prism inserted	-0.0011	-0.0016	-0.0013
Frost inserted	-0.0008	-0.0012	-0.0011

In other embodiments, parameter adjustment system according to the disclosure may compensate for changes in one or both of Duv and CCT value produced by optical device changes. In such embodiments, a table similar to Table 3 may include change values for both Duv and CCT that are caused by optical devices alone or in combination. As described for Table 3, such Duv and CCT value changes can be applied to commanded Duv and/or CCT values and

resulting adjusted Duv and/or CCT values be used with the lookup tables and interpolation techniques described above.

In some embodiments, a Duv parameter adjustment system according to the disclosure may be used with an additive color mixing LED light source that includes LEDs or groups of LEDs of a plurality of colors, as previously described. In some such embodiments, the additive color mixing LED light source includes LEDs emitting light in a plurality of colors such that, by adjusting the relative brightness of each color of LED, the color of the output beam can also be adjusted. The LED colors used for an additive color mixing system, may be chosen from, but are not restricted to, red, green, blue, cyan, amber, lime, and white.

Each of the groups of like-colored LEDs emits light in a characteristic wavelength range. Examples of such wavelength ranges in some embodiments are 580 nm to 700 nm for red LEDs, 470 nm to 610 nm for green LEDs, 400 nm to 530 nm for blue LEDs, and 550 nm to 670 nm for amber LEDs. In other embodiments, LEDs emitting light in other characteristic wavelength ranges may be used.

In such embodiments, as the user adjusts the command value on the Duv control channel, the control system **600** automatically recalculates the relative brightness of one or more colors of LED so that movement of the emitted color is constrained along a user-selected CCT isotherm. Thus, the Duv parameter adjustment system according to the disclosure enables the user of a fixture with an additive color mixing LED light engine to visually match luminaires according to the disclosure to the eye and/or camera without altering the CCT values of the luminaires and to do so without having to manually adjust individual brightness of each color of LED.

Luminaires according to the disclosure comprise an LED light source that emits a colored light beam having a color that is determined by controlling a brightness of each of a plurality of ranges of wavelengths. In such an LED light source having a subtractive color system (such as the color mixing module **515** of FIG. 5), the ranges of wavelengths are determined by filter characteristics of the like-colored pairs of filters in the dichroic filters **513** and **514** and the brightness of each range of wavelengths is controlled by the movement of the filters into and out of the light beam. In such an LED light source having such an additive color mixing system, the ranges of wavelengths are determined by the colors of the LEDs and the brightness of each range of wavelengths is controlled by the brightness of each color of LED.

In summary, the Duv parameter adjustment system according to the disclosure provides at least the following benefits in both subtractive and additive color mixing luminaires:

- a. Allows the user to use a single control to match the Duv value of light emitted from a luminaire according to the disclosure to another luminaire without changing the CCT value, using variable subtractive color mixing.
- b. Provides an automatic system for modifying the Duv value of light emitted from a luminaire according to the disclosure using variable subtractive color mixing so as to keep the Duv constant as optical devices are adjusted or inserted or removed from the light beam of the luminaire.

FIG. 6 presents a block diagram of the control system (or controller) **600** for an automated luminaire **12** according to the disclosure. The control system **600** is suitable for use to control the LED light source **550** and color mixing module **515** and other optical modules of the luminaire **400**. The control system **600** is also suitable for controlling other

control functions of the automated luminaire 12. The control system 600 includes a processor 602 electrically coupled to a memory 604. The processor 602 is implemented by hardware and software. The processor 602 may be implemented as one or more Central Processing Unit (CPU) chips, cores (e.g., as a multi-core processor), field-programmable gate arrays (FPGAs), application specific integrated circuits (ASICs), and digital signal processors (DSPs).

The processor 602 is further electrically coupled to and in communication with a communication interface 606. The communication interface 606 is coupled to, and configured to communicate via, the data link 14. The processor 602 is also coupled via a control interface 608 to one or more sensors, motors, actuators, controls, and/or other devices of the automated luminaire 12. The processor 602 is configured to receive control signals from the data link 14 via the communication interface 606 and, in response, to control the LED light engine, color mixing systems and other mechanisms of the automated luminaire 12 via the control interface 608.

The control system 600 is suitable for implementing processes, color control, and other functionality as disclosed herein, which may be implemented as instructions stored in the memory 604 and executed by the processor 602. The memory 604 comprises one or more disks and/or solid-state drives and may be used to store instructions and data that are read and written during program execution. The memory 604 may be volatile and/or non-volatile and may be read-only memory (ROM), random access memory (RAM), ternary content-addressable memory (TCAM), and/or static random-access memory (SRAM).

FIG. 7 presents a flow chart of a process 700 for color control of an automated luminaire according to the disclosure. The process 700 is described with reference to elements of the luminaire 400, the LED light engine 500, and the control system 600 described with reference to FIGS. 4, 5, and 6, respectively.

In step 702, the control system 600 receives via the data link 14 an optical device command, which includes a setting value for an optical device configured to modify the light beam emitted by the automated luminaire 12, such as the gobos 402, the prism and frost systems 404, the zoom lens system 406, an ND filter dimmer, or an electronically dimmed LED light source. In step 704, the control system 600 causes the optical device to move based on the setting value.

In step 706, the control system 600 determines a change in a Duv value of a color of the light beam emitted by the automated luminaire 12, where the Duv value change is caused by the optical device moving to the setting value. In some embodiments, in step 706 the control system 600 determines changes in one or both the Duv and CCT values of the light beam, caused by the optical device moving to the setting value. In step 708, based on the Duv and/or CCT value changes, a current correlated color temperature (CCT) value of a CCT isotherm, and a current Duv value, the control system 600 determines a first position of a first color filter of the luminaire and a second position of a second color filter of the automated luminaire 12. In step 710, the control system 600 causes a color of the light beam to change by causing the first color filter to move to the first position in the light beam and the second color filter to move to the second position in the light beam.

While only some embodiments of the disclosure have been described herein, those skilled in the art, having benefit of this disclosure, will appreciate that other embodiments may be devised which do not depart from the scope of the

disclosure. While the disclosure has been described in detail, it should be understood that various changes, substitutions, and alterations can be made hereto without departing from the spirit and scope of the disclosure.

What is claimed is:

1. A luminaire, comprising:

a light-emitting diode (LED) light source configured to emit a white light beam;

first and second color filters configured to receive the white light beam and emit a colored light beam;

an optical device configured to receive the colored light beam, modify the colored light beam, and emit a modified light beam; and

a control system electrically coupled to the first and second color filters and the optical device, the control system configured to:

receive an optical device command via a data link, the optical device command comprising a setting value for the optical device; and

in response to the optical device command:

cause the optical device to move based on the setting value;

determine a Duv value change, the Duv value change caused by the optical device, based on the setting value;

determine a first position of the first color filter and a second position of the second color filter based on the Duv value change, a current correlated color temperature (CCT) value of a CCT isotherm, and a current Duv value; and

cause the first color filter to move to the first position and the second color filter to move to the second position.

2. The luminaire of claim 1, wherein the control system is further configured to:

receive a Duv command via the data link, the Duv command comprising a received Duv value for the colored light beam;

in response to the Duv command, determine a third position of the first color filter and a fourth position of the second color filter based on the received Duv value, the Duv value change, and the current CCT value; and cause the first color filter to move to the third position and the second color filter to move to the fourth position.

3. The luminaire of claim 1, wherein the luminaire further comprises, the control system further configured to:

receive a CCT command via the data link, the CCT command comprising a received CCT value for the colored light beam;

in response to the CCT command, determine a fifth position of the first color filter and a sixth position of the second color filter based on the received CCT value, the Duv value change, and the current Duv value; and cause the first color filter to move to the fifth position and the second color filter to move to the sixth position.

4. The luminaire of claim 1, wherein the optical device is a first optical device, the optical device command is a first optical device command, the setting value is a first setting value, and the modified light beam is a first modified light beam and wherein the luminaire further comprises a second optical device configured to receive the first modified light beam and emit a second modified light beam, the control system further configured to:

receive a second optical device command via the data link, the second optical device command comprising a second setting value for the second optical device; and

in response to the second optical device command:

## 13

cause the second optical device to move based on the second setting value;  
 determine a second Duv value change based on the first setting value and the second setting value;  
 determine a seventh position of the first color filter and an eighth position of the second color filter based on the second Duv value change, the current CCT value, and the current Duv value; and  
 cause the first color filter to move to the first position and the second color filter to move to the second position.

5. The luminaire of claim 1, wherein the white light beam comprises a plurality of white light beams.

6. The luminaire of claim 5, wherein the light beams of the plurality of white light beams are diverging light beams.

7. The luminaire of claim 5, wherein in at least one position of the first color filter, light beams of a first subset of the plurality of white light beams pass through the first color filter.

8. The luminaire of claim 1, wherein the control system is further configured to, in response to the optical device command:

determine a CCT value change, the CCT value change caused by the optical device, based on the setting value; and

determine the first position of the first color filter and the second position of the second color filter based on the Duv value change, the CCT value change, the current correlated color temperature (CCT) value of the CCT isotherm, and the current Duv value.

9. A luminaire, comprising:

a light-emitting diode (LED) light source configured to emit a white light beam;

first and second color filters configured to receive the white light beam and emit a colored light beam; and

a control system electrically coupled to the first and second color filters, the control system configured to: receive a Duv command via a data link, the Duv command comprising a received Duv value for the colored light beam;

in response to the Duv command, determine a first position of the first color filter and a second position of the second color filter based on the received Duv value and a correlated color temperature (CCT) value of a CCT isotherm; and

cause the first color filter to move to the first position and the second color filter to move to the second position.

10. The luminaire of claim 9, wherein the control system is further configured to:

receive a CCT command via the data link, the CCT command comprising the CCT value for the colored light beam; and

in response to the CCT command, determine a third position of the first color filter and a fourth position of the second color filter based on the CCT value and the received Duv value; and

cause the first color filter to move to the third position and the second color filter to move to the fourth position.

11. The luminaire of claim 9, wherein the luminaire further comprises an optical device configured to receive the colored light beam, modify the colored light beam, and emit a modified light beam, the control system further configured to:

determine a setting value of the optical device;  
 determine a Duv value change, the Duv value change caused by the optical device, based on the setting value;

## 14

determine a fifth position of the first color filter and a sixth position of the second color filter based on the Duv value change, the CCT value, and the received Duv value; and

cause the first color filter to move to the fifth position and the second color filter to move to the sixth position.

12. The luminaire of claim 11, wherein the optical device is a first optical device having a first setting and wherein the luminaire further comprises a second optical device configured to receive the modified light beam and emit a second modified light beam, the control system further configured to:

determine a second setting of the second optical device;  
 determine a second Duv value change based on the first setting of the first optical device and the second setting of the second optical device;

determine a seventh position of the first color filter and an eighth position of the second color filter based on the second Duv value change, the CCT value, the received Duv value; and

cause the first color filter to move to the seventh position and the second color filter to move to the eighth position.

13. The luminaire of claim 9, wherein the white light beam comprises a plurality of white light beams.

14. The luminaire of claim 13, wherein the light beams of the plurality of white light beams are diverging light beams.

15. The luminaire of claim 13, wherein in at least one position of the first color filter, light beams of a first subset of the plurality of white light beams pass through the first color filter.

16. A method of controlling a color of a light beam emitted by a luminaire, the method comprising:

receiving by a control system of a luminaire via a data link an optical device command, the optical device command comprising a setting value for an optical device configured to modify a light beam emitted by the luminaire;

causing the optical device to move based on the setting value;

determining a Duv value change in a color of the light beam emitted by the luminaire, the Duv value change caused by the optical device based on the setting value;

determining a first position of a first color filter of the luminaire and a second position of a second color filter of the luminaire, based on the Duv value change, a current correlated color temperature (CCT) value of a CCT isotherm, and a current Duv value; and

changing the color of the light beam by causing the first color filter to move to the first position in the light beam and the second color filter to move to the second position in the light beam.

17. The method of claim 16, further comprising:

receiving by the control system via the data link a Duv command, the Duv command comprising a received Duv value for the light beam;

based on the received Duv value, the Duv value change, and the current CCT value, determining a third position of the first color filter and a fourth position of the second color filter; and

changing the color of the light beam by causing the first color filter to move to the third position in the light beam and the second color filter to move to the fourth position in the light beam.

15

18. The method of claim 16, further comprising:  
 receiving by the control system via the data link a CCT  
 command, the CCT command comprising a received  
 CCT value for the light beam;  
 based on the received CCT value, the Duv value change, 5  
 and the current Duv value, determining a fifth position  
 of the first color filter and a sixth position of the second  
 color filter; and  
 changing the color of the light beam by causing the first  
 color filter to move to the fifth position in the light 10  
 beam and the second color filter to move to the sixth  
 position in the light beam.

19. The method of claim 16, wherein the optical device is  
 a first optical device, the optical device command is a first  
 optical device command, and the setting value is a first 15  
 setting value, the method further comprising:  
 receiving by the control system via the data link a second  
 optical device command, the second optical device  
 command comprising a second setting value for a  
 second optical device configured to modify the light 20  
 beam emitted by the luminaire;  
 causing the second optical device to move based on the  
 second setting value, wherein the Duv value change is  
 caused by the first and second optical devices, based on  
 the first and second setting values;

16

based on the Duv value change, the CCT value, and the  
 current Duv value, determining a seventh position of  
 the first color filter of the luminaire and an eighth  
 position of the second color filter of the luminaire; and  
 changing the color of the light beam by causing the first  
 color filter to move to the seventh position in the light  
 beam and the second color filter to move to the eighth  
 position in the light beam.

20. The method of claim 16, further comprising:  
 determining a CCT value change in the color of the light  
 beam emitted by the luminaire, the CCT value change  
 caused by the optical device based on the setting value,  
 wherein the first position of the first color filter of the  
 luminaire and the second position of the second color  
 filter of the luminaire are determined based on the Duv  
 value change, the CCT value change, the current CCT  
 value of the CCT isotherm, and the current Duv value;  
 and  
 determining the first position of the first color filter and  
 the second position of the second color filter based on  
 the Duv value change, the CCT value change, the  
 current CCT value of the CCT isotherm, and the current  
 Duv value.

\* \* \* \* \*