



US010845030B1

(12) **United States Patent**
Tornyai

(10) **Patent No.:** **US 10,845,030 B1**

(45) **Date of Patent:** **Nov. 24, 2020**

(54) **LIGHTING FIXTURE WITH INTERNAL SHUTTER BLADE**

(71) Applicant: **Electronic Theatre Controls, Inc.**,
Middleton, WI (US)

(72) Inventor: **Frank Tornyai**, Santa Maria, CA (US)

(73) Assignee: **Electronic Theatre Controls, Inc.**,
Middleton, WI (US)

(*) Notice: Subject to any disclaimer, the term of this patent is extended or adjusted under 35 U.S.C. 154(b) by 0 days.

(21) Appl. No.: **16/801,543**

(22) Filed: **Feb. 26, 2020**

(51) **Int. Cl.**
F21V 11/02 (2006.01)
F21V 7/04 (2006.01)
F21V 5/00 (2018.01)
F21V 5/04 (2006.01)
F21V 7/00 (2006.01)
F21Y 113/13 (2016.01)

(Continued)

(52) **U.S. Cl.**
CPC **F21V 7/04** (2013.01); **F21V 5/007** (2013.01); **F21V 5/008** (2013.01); **F21V 5/045** (2013.01); **F21V 7/0066** (2013.01); **F21Y 2105/18** (2016.08); **F21Y 2113/13** (2016.08); **F21Y 2115/10** (2016.08)

(58) **Field of Classification Search**
CPC F21Y 2115/10; F21Y 2105/00; F21Y 2105/12; F21Y 2105/14; F21Y 2105/16; F21Y 2105/18; F21V 11/18; F21V 11/185; F21V 14/08; F21V 5/007; F21V 7/04

See application file for complete search history.

(56) **References Cited**

U.S. PATENT DOCUMENTS

4,179,726 A 12/1979 Aron
5,622,426 A 4/1997 Roman et al.
6,200,002 B1 3/2001 Marshall et al.
(Continued)

FOREIGN PATENT DOCUMENTS

EP 1482240 B1 3/2008
EP 1844262 B1 4/2009
WO 2015138483 A2 9/2015

OTHER PUBLICATIONS

Diaz, "Prototyping illuminations systems with stock optical components" Photonik International 2012 originally published in German in Photonik Mar. 2012 (4 Pages).

(Continued)

Primary Examiner — Robert J May

(74) *Attorney, Agent, or Firm* — Michael Best and Friedrich LLP

(57) **ABSTRACT**

A lighting fixture includes a housing, light source, reflector, tandem lens array, shutter blade, and condenser. The housing includes an outlet. An optical axis extends centrally through the outlet. The light source includes an array of light-emitting diodes. The reflector has an input end positioned along the optical axis between the light source and the outlet. The reflector has an output end positioned along the optical axis between the input end and the outlet. The light source emits light from the input end through the output end. The tandem lens array is positioned along the optical axis between the output end and the outlet. The shutter blade is positioned along the optical axis between the tandem lens array and the outlet. The shutter blade is disposed at least partially within the housing. The condenser, including a lens, is positioned along the optical axis between the shutter blade and the outlet.

20 Claims, 11 Drawing Sheets

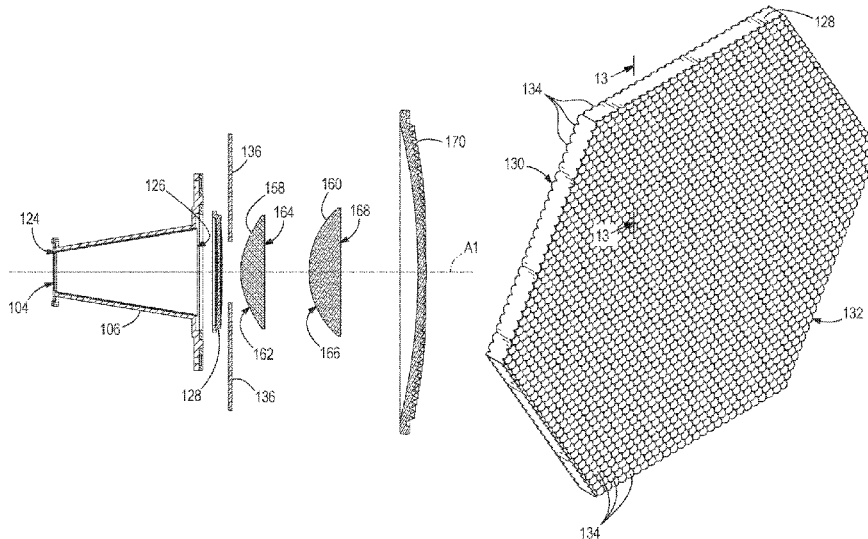

- (51) **Int. Cl.**
F21Y 115/10 (2016.01)
F21Y 105/18 (2016.01)

(56) **References Cited**
 U.S. PATENT DOCUMENTS

6,222,623	B1	4/2001	Wetherell
6,382,803	B1	5/2002	Arumugasaamy
6,527,411	B1	3/2003	Sayers
6,536,914	B2	3/2003	Hoelen et al.
6,547,416	B2	4/2003	Pashley et al.
6,834,982	B2	12/2004	Dedoro
7,163,317	B2	1/2007	Warnecke et al.
7,614,767	B2	11/2009	Zulim et al.
7,777,955	B2	8/2010	Cassarly et al.
7,874,487	B2	1/2011	Nunnink et al.
7,946,729	B2	5/2011	Ivey et al.
8,292,463	B2	10/2012	Speier et al.
8,456,107	B2	6/2013	Saem
8,529,103	B2	9/2013	Tukker et al.
8,602,601	B2	12/2013	Khazi et al.
8,733,949	B2	5/2014	Chong et al.
8,814,376	B2	12/2014	Nicolai et al.
8,915,612	B2	12/2014	Kurt et al.
9,169,997	B2	10/2015	Kurt et al.
9,249,947	B2	2/2016	Goldstein et al.

9,746,596	B2	8/2017	Preston et al.
9,989,217	B2	6/2018	Junk et al.
9,995,872	B2	6/2018	Angelini et al.
10,018,329	B1	7/2018	Belliveau
10,031,405	B2*	7/2018	Matsubara F21K 9/64
10,317,044	B2*	6/2019	Di Trapani F21S 8/06
2008/0266893	A1	10/2008	Speier
2008/0310152	A1	12/2008	Verbrugh et al.
2010/0113101	A1	10/2010	Adams
2010/0284201	A1	11/2010	Alasaanela
2011/0013389	A1	1/2011	Willemsen et al.
2012/0140463	A1	6/2012	Kinzer et al.
2013/0329429	A1	12/2013	Lowes et al.
2014/0117877	A1	5/2014	Mapel et al.
2015/0362654	A1	12/2015	Sadasivan et al.
2016/0018064	A1	1/2016	Jurik et al.
2016/0208999	A1	7/2016	Junk
2016/0370529	A1	12/2016	Angelini et al.
2018/0180268	A1	6/2018	Jurik et al.

OTHER PUBLICATIONS

Intematix, "Mixing Chamber Design Considerations for ChromaLit™ Remote Phosphor Light Sources", Website: <http://www.intematix.com/uploads/application%20notes/MixingChamberDesign.pdf>, Application Literature dated Dec. 14, 2017 (11 Pages).

* cited by examiner

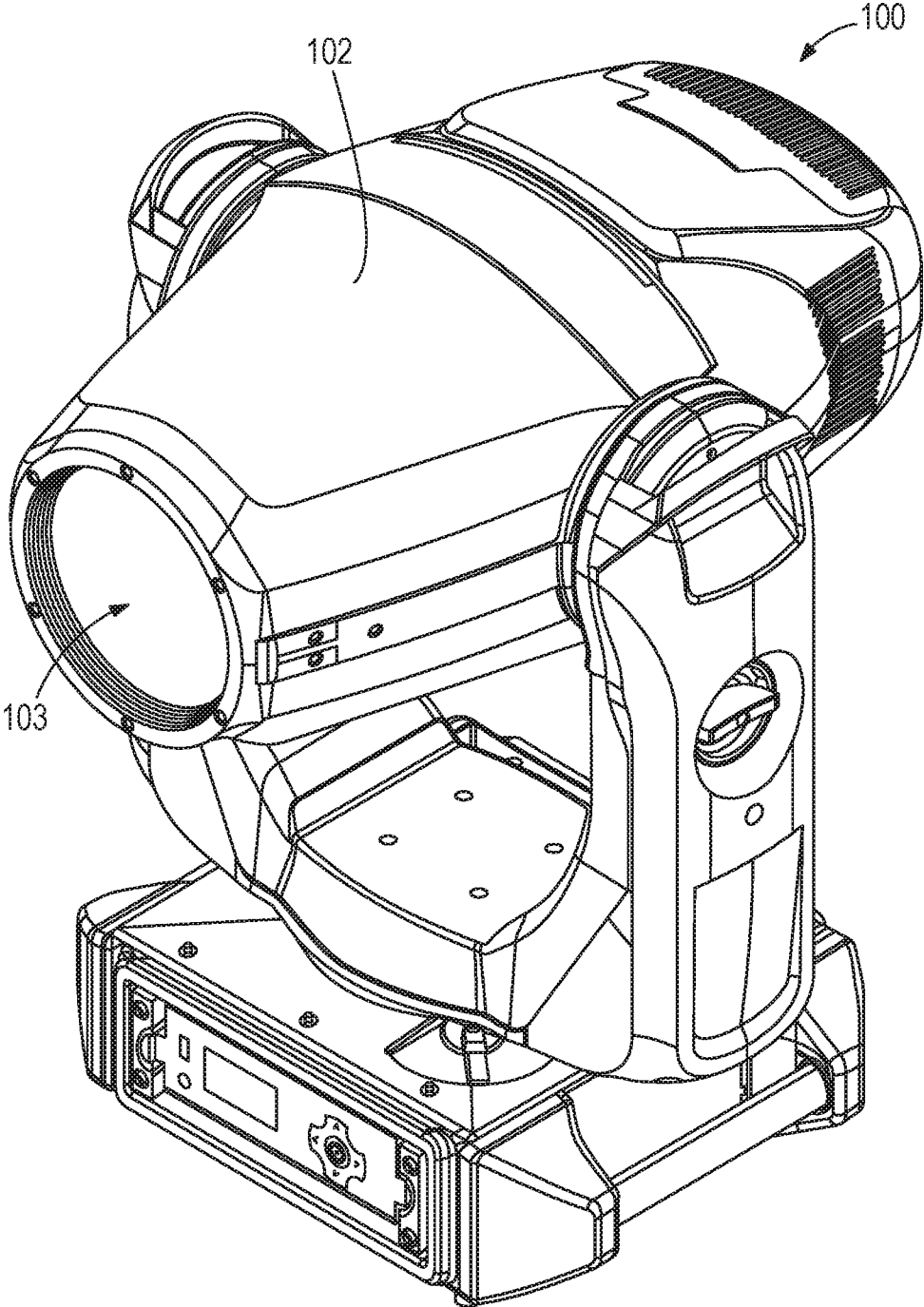

FIG. 1

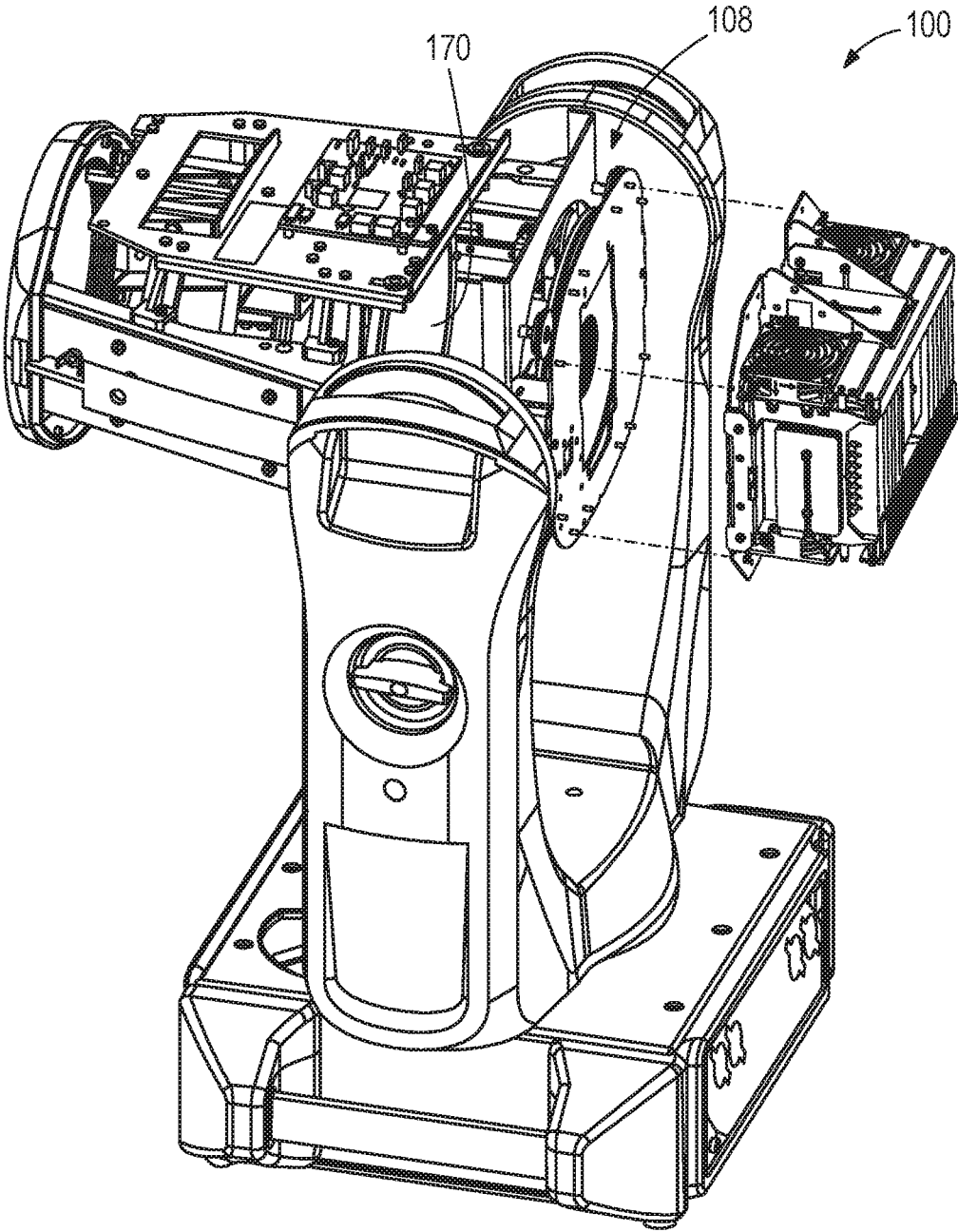

FIG. 2

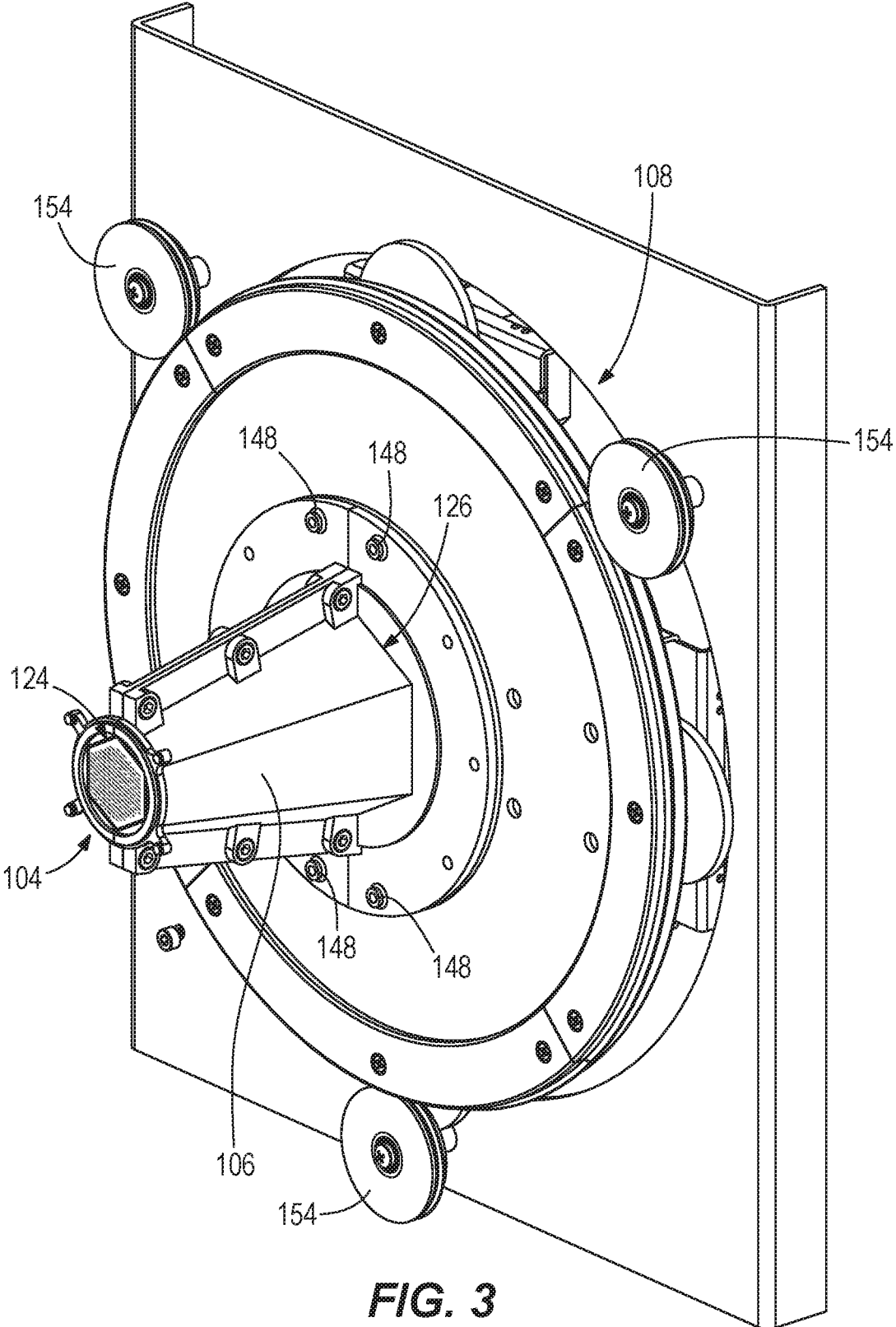

FIG. 3

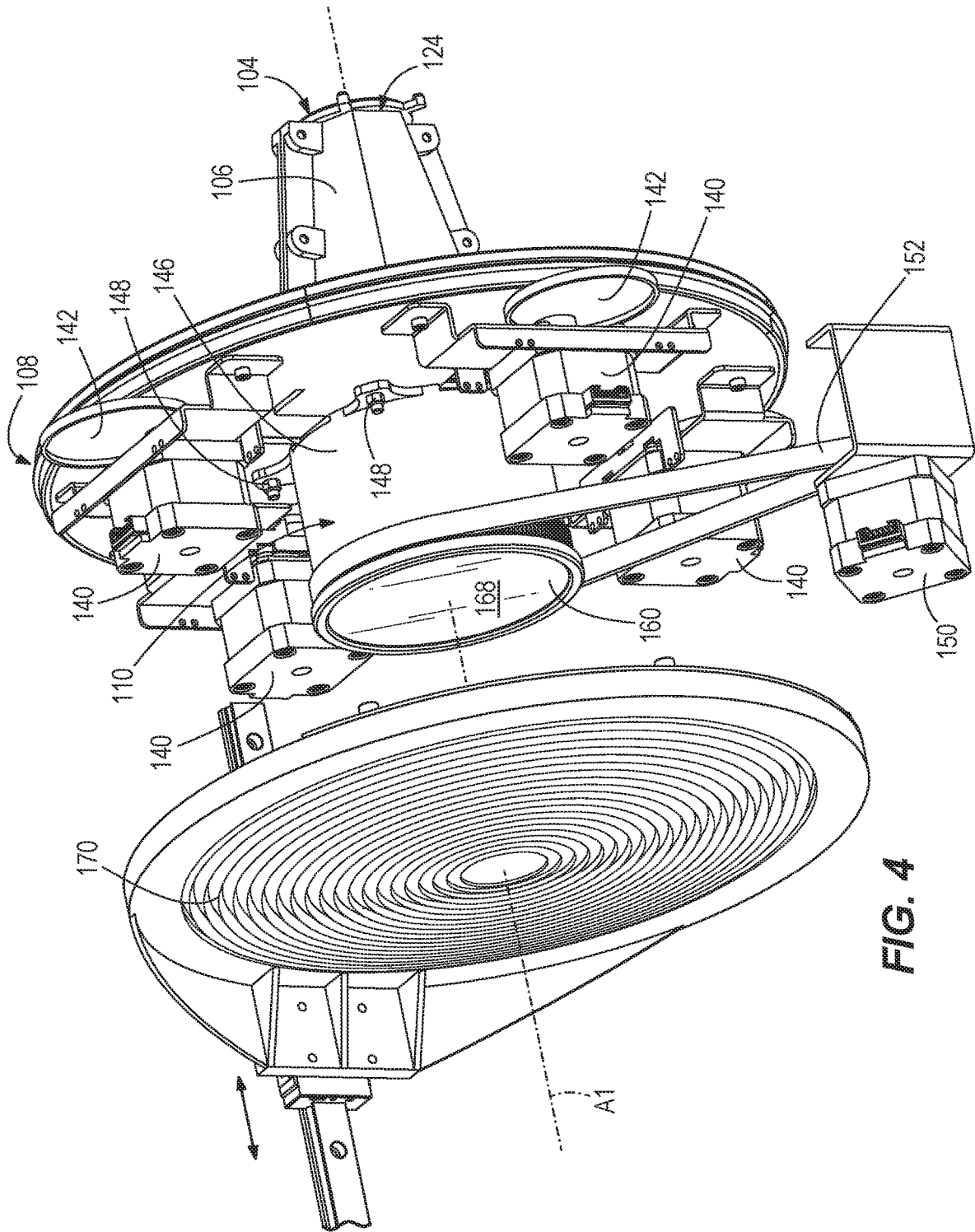

FIG. 4

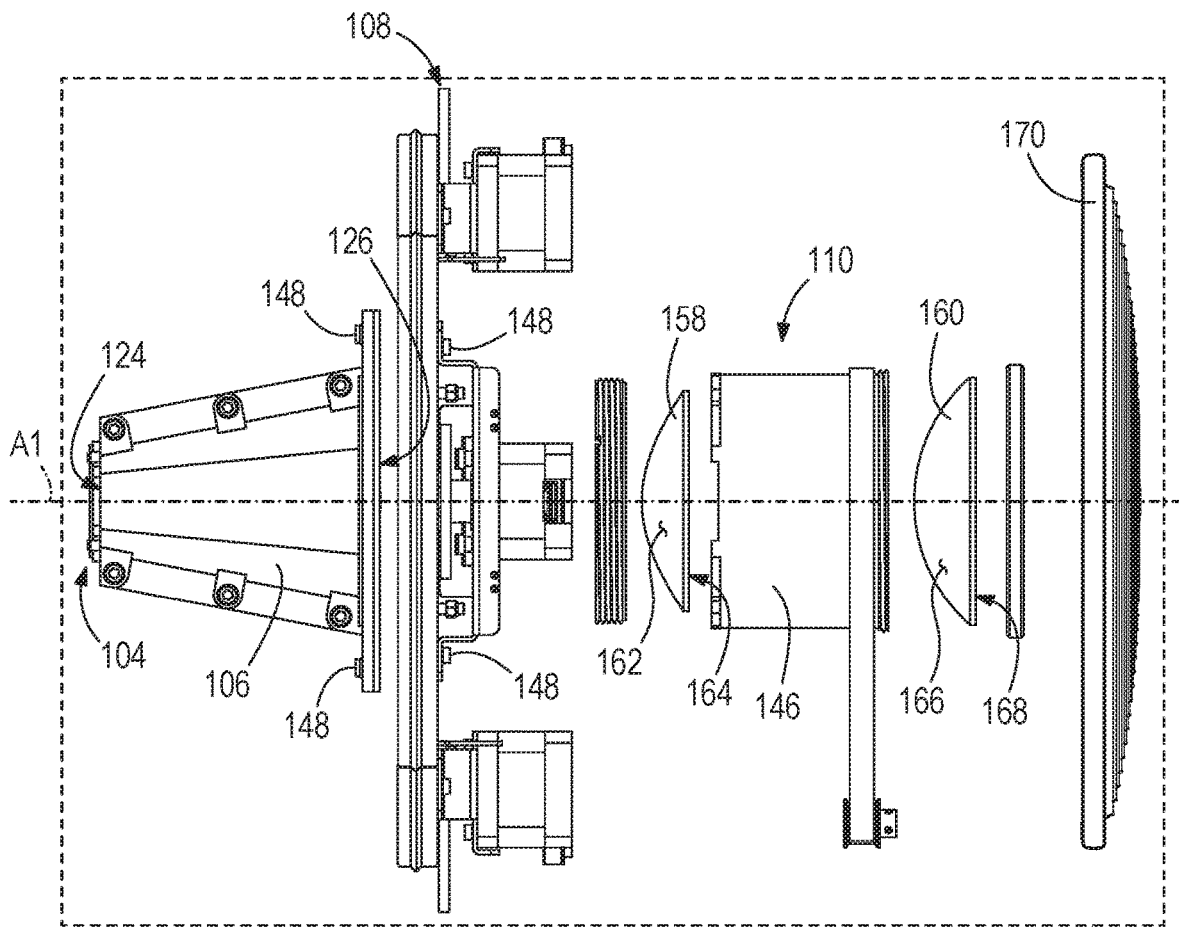

FIG. 5

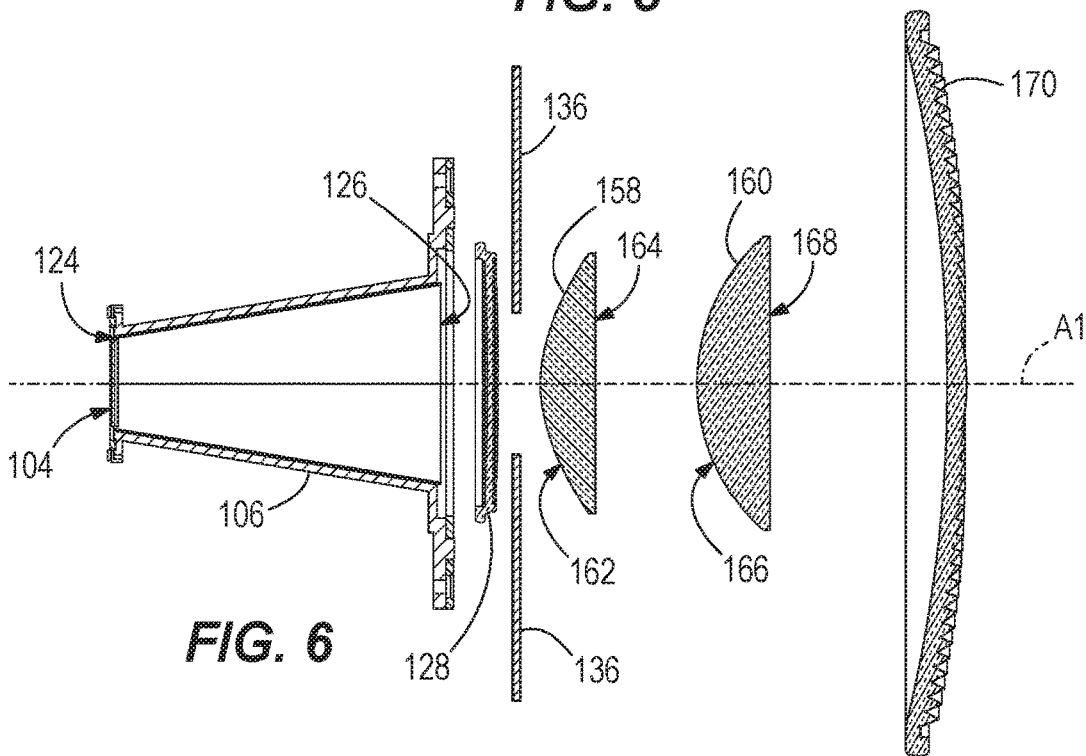

FIG. 6

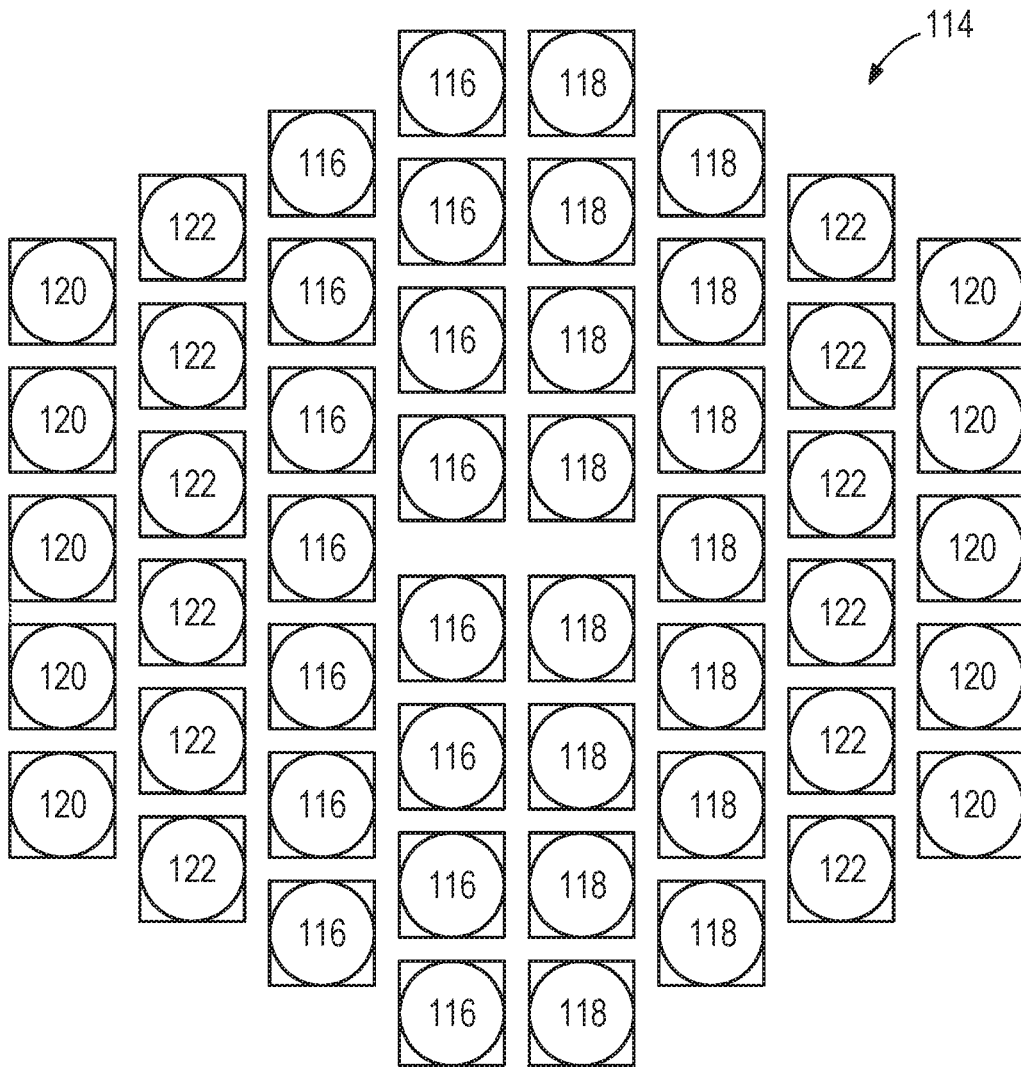

FIG. 7

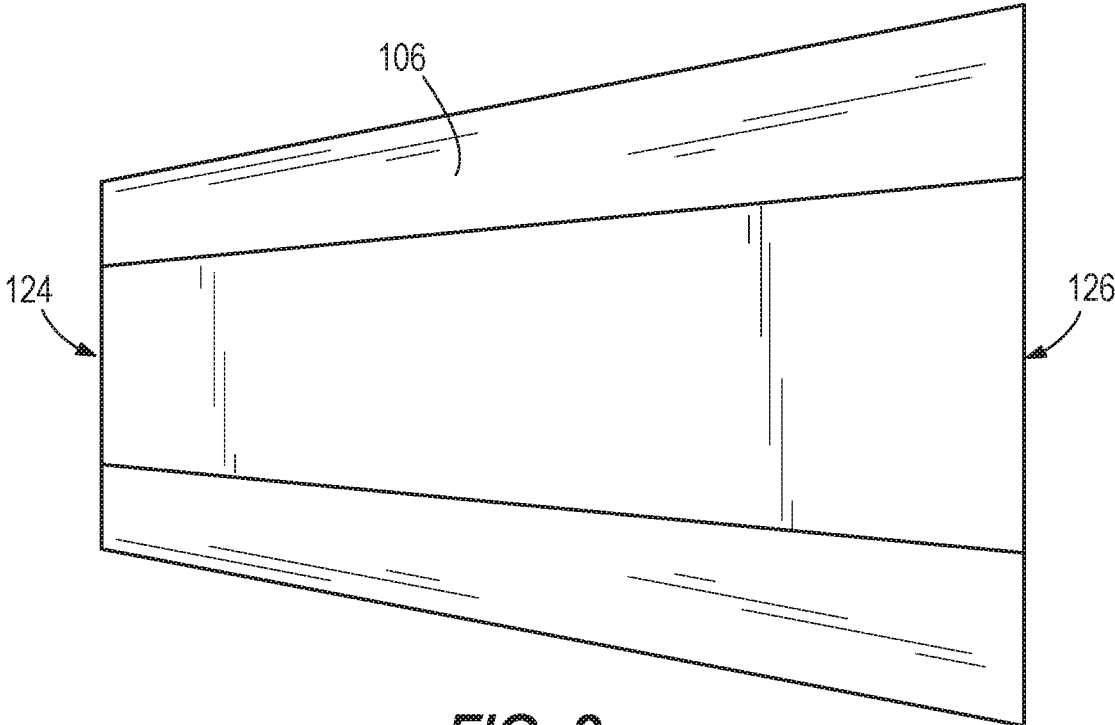

FIG. 8

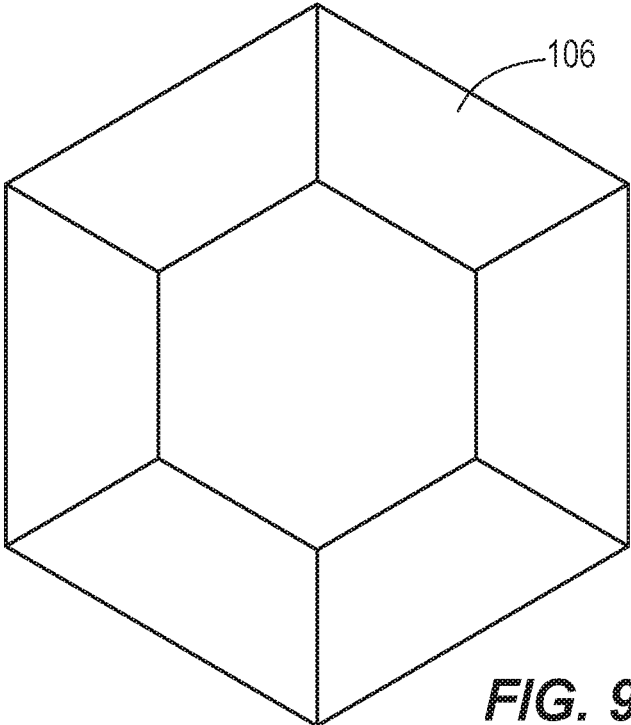

FIG. 9

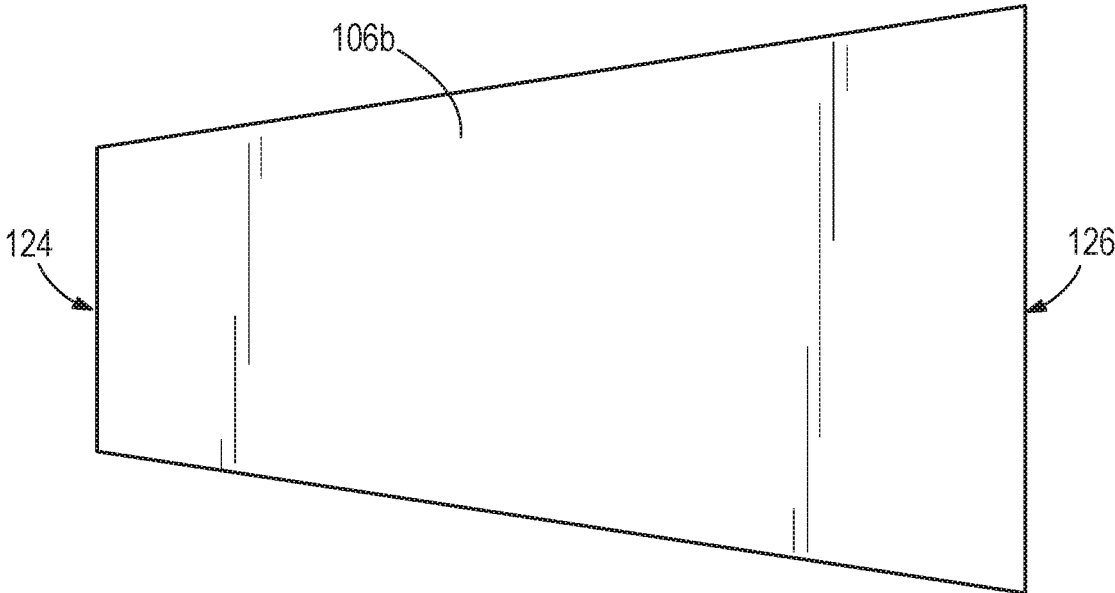

FIG. 10

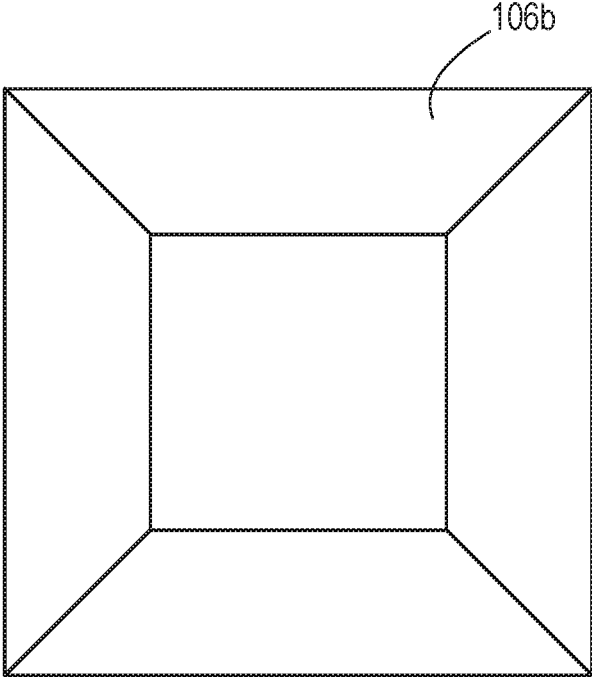

FIG. 11

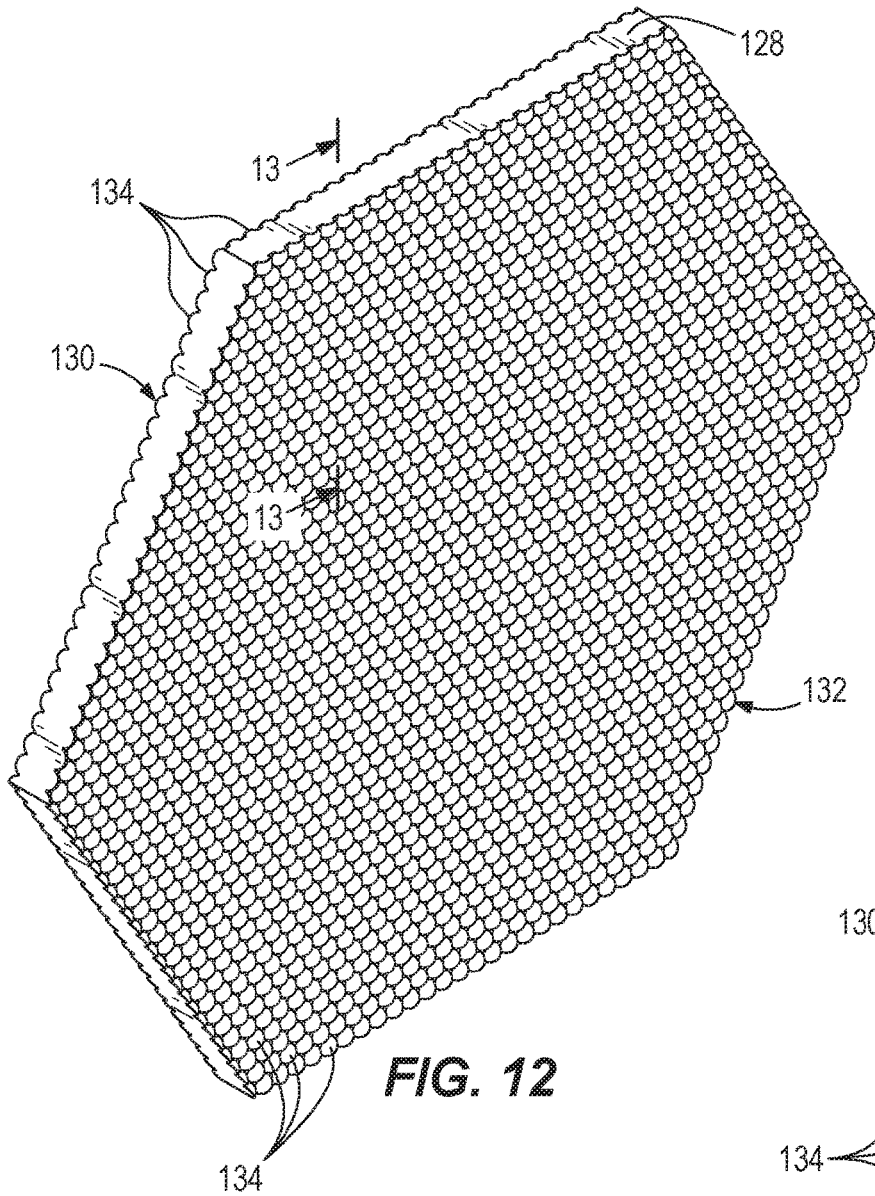

FIG. 12

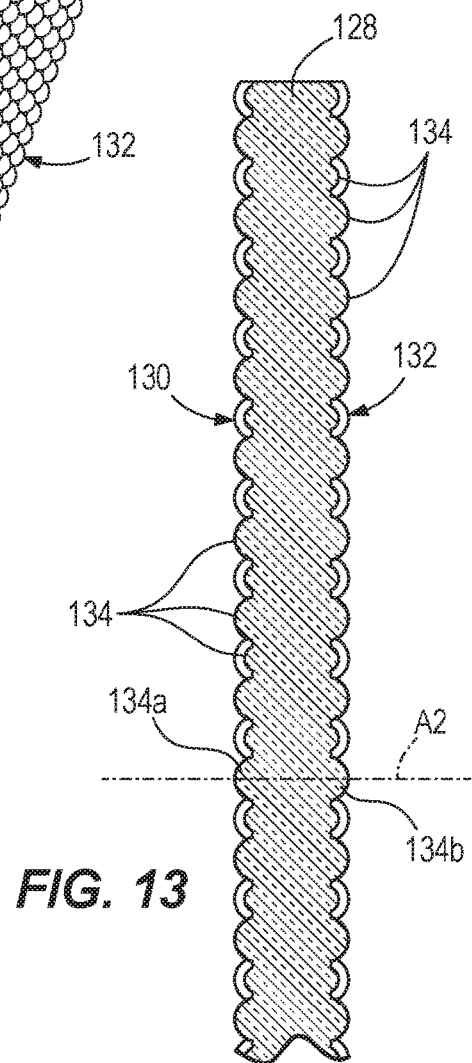

FIG. 13

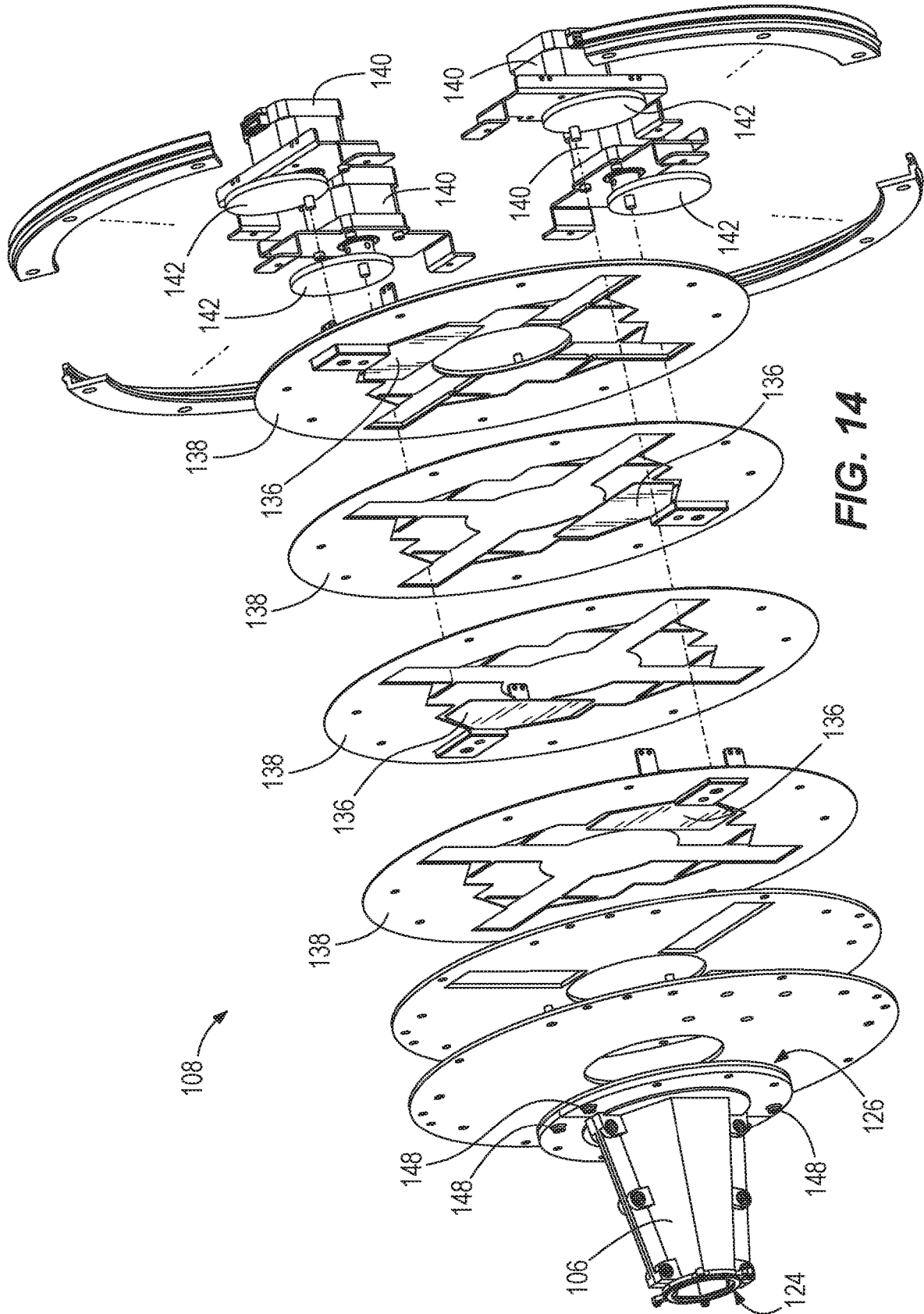
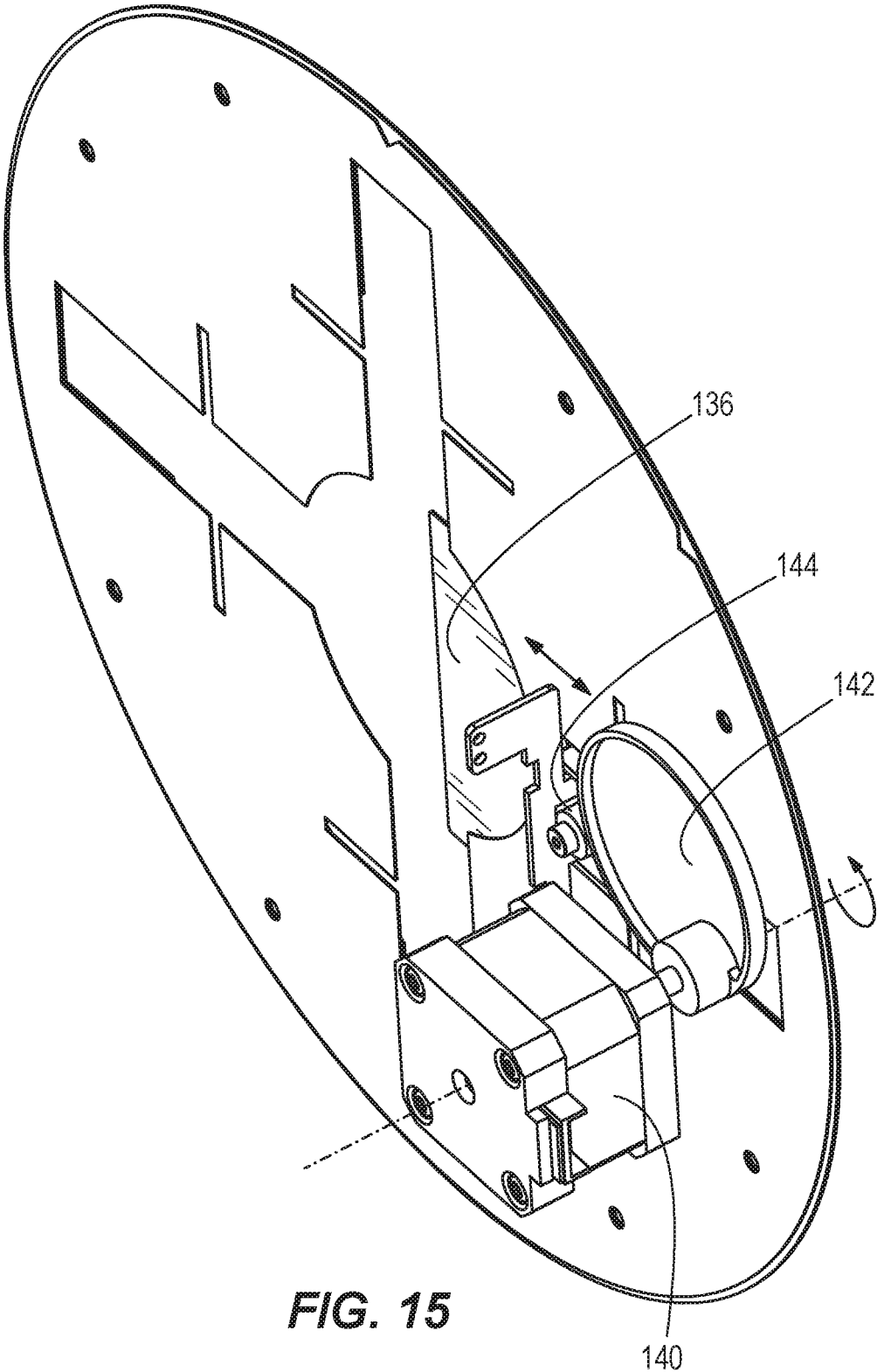

FIG. 14



1

LIGHTING FIXTURE WITH INTERNAL SHUTTER BLADE

BACKGROUND

The present disclosure relates to lighting fixtures and, more particularly, to lighting fixtures that utilize light-emitting diodes (LEDs).

SUMMARY

In one aspect, the disclosure relates to a lighting fixture including a housing, a light source, a reflector, a tandem lens array, a shutter blade, and a condenser. The housing includes an outlet through which light passes. An optical axis of the lighting fixture extends centrally through the outlet of the housing. The light source includes an array of light-emitting diodes disposed within the housing. The reflector has an input end positioned along the optical axis between the light source and the outlet of the housing. The reflector also has an output end positioned along the optical axis between the input end and the outlet of the housing. The light source emits light through the reflector from the input end through the output end. The tandem lens array is positioned along the optical axis between the output end of the reflector and the outlet of the housing. The shutter blade is positioned along the optical axis between the tandem lens array and the outlet of the housing. The shutter blade is disposed at least partially within the housing. The condenser is positioned along the optical axis between the shutter blade and the outlet of the housing. The condenser includes a lens. In some embodiments, the lens includes an aspheric lens.

In another aspect, the disclosure relates to a lighting fixture including a housing, a light source, a tapered reflector, a tandem lens array, a shutter blade, and a condenser. The light source includes an array of light-emitting diodes disposed within the housing. The tapered reflector is disposed within the housing and includes an input end and an output end. The input end is adjacent the light source. The output end is opposite the input end. The output end is wider than the input end. The light source emits light through the tapered reflector from the input end through the output end. The tandem lens array is adjacent the output end of the reflector. The tandem lens array is disposed within the housing and includes a first side and a second side. The first side is facing toward the light source and includes an array of lenses. The second side is opposite the first side and includes an array of lenses. The shutter blade is adjacent the second side of the tandem lens array. The shutter blade is disposed at least partially within the housing. The condenser is adjacent the shutter blade. The condenser includes two condenser lenses disposed within the housing.

Other aspects of the disclosure will become apparent by consideration of the detailed description and accompanying drawings.

BRIEF DESCRIPTION OF THE DRAWINGS

FIG. 1 illustrates a perspective view of a lighting fixture, according to embodiments described herein.

FIG. 2 illustrates a partially exploded view of the lighting fixture of FIG. 1.

FIG. 3 illustrates a rear perspective view of a light source, a reflector, and a shutter system of the lighting fixture of FIG. 1.

2

FIG. 4 illustrates a front perspective view of the light source, the reflector, the shutter system, the condenser, and a Fresnel lens of the lighting fixture of FIG. 1.

FIG. 5 illustrates a side elevation view of an exploded portion of the lighting fixture of FIG. 1.

FIG. 6 schematically illustrates a cross-sectional elevation view of the light pathway of the lighting fixture of FIG. 1.

FIG. 7 illustrates an LED color arrangement of an LED array of the lighting fixture of FIG. 1.

FIG. 8 illustrates a side elevation view reflector of the lighting fixture of FIG. 1.

FIG. 9 illustrates a front elevation view of the reflector of FIG. 8.

FIG. 10 illustrates a side elevation view of a reflector according to another embodiment described herein.

FIG. 11 illustrates a front elevation view of the reflector of FIG. 10.

FIG. 12 illustrates a perspective view of a tandem lens array of the lighting fixture of FIG. 1.

FIG. 13 illustrates a cross-sectional elevation view of the tandem lens array of FIG. 12.

FIG. 14 illustrates a rear perspective view of the reflector and an exploded shutter system of the lighting fixture of FIG. 1.

FIG. 15 illustrates a front perspective view of a portion of the shutter system of FIG. 14.

DETAILED DESCRIPTION

Before any embodiments are explained in detail, it is to be understood that the embodiments are not limited in application to the details of the configuration and arrangement of components set forth in the following description or illustrated in the accompanying drawings. The embodiments are capable of being practiced or of being carried out in various ways. Also, it is to be understood that the phraseology and terminology used herein are for the purpose of description and should not be regarded as limiting. The use of “including,” “comprising,” or “having” and variations thereof are meant to encompass the items listed thereafter and equivalents thereof as well as additional items. Unless specified or limited otherwise, the terms “mounted,” “connected,” “supported,” and “coupled” and variations thereof are used broadly and encompass both direct and indirect mountings, connections, supports, and couplings.

FIG. 1 illustrates a lighting fixture, or luminaire **100**, having a housing **102** with an outlet **103** defined therein. The outlet **103** allows light to pass therethrough to exit the light fixture **100**. As shown in FIG. 2, which illustrates the lighting fixture **100** with the housing **102** removed, various components are contained partially or completely within the housing **102**.

Referring to FIGS. 3-6, the lighting fixture **100** includes a light source **104**, a light pipe, or reflector, **106**, a shutter system **108**, and a condenser **110**, which are disposed within the housing **102**. The lighting fixture **100** is particularly suited for use during live performances including theater productions, concerts, television or movie studio productions, or the like.

With reference to FIG. 7, the light source **104** includes an array **114** of light-emitting diodes (LEDs). In the illustrated embodiment, the array **114** of LEDs is in the shape of a hexagon, which generally matches or corresponds to the cross-sectional shape of an input end **124** of the reflector **106**. In other embodiments, a reflector **106** having another cross-sectional shape may be used. In such embodiments, the array **114** of LEDs can match or correspond to the

cross-sectional shape of the reflector **106**. The illustrated array **114** includes fifty two individual LEDs spaced closely together. The LEDs may be, for instance, Luxeon C LEDs that cooperate to produce about 10,000 lumens. The array **114** can include various colors of LEDs including, for instance, red **116**, lime **118**, green **120**, and indigo **122** color LEDs. In many lighting fixtures, the LEDs must be carefully arranged in order to promote adequate mixing of the light produced from the LEDs. For instance, the LEDs are often arranged symmetrically. In some embodiments, the lighting fixture **100** includes the array **114** including at least two different color LEDs, and the arrangement of the LEDs is asymmetrical with regard to color. The different color LEDs may be radially asymmetrical, bilaterally asymmetrical, or the like. Stated another way, the pattern of LEDs according to color may be different about the optical axis **127** passing through the center of the light source **104**. In some embodiments, the pattern of LEDs according to color may be different on one side of the optical axis **127** from on the opposite side of the optical axis **127**. In still other embodiments, the LEDs may be scattered according to color such that no pattern exists. In the illustrated embodiment, the array **114** includes straight strips of each of red **116**, lime **118**, green **120**, and indigo **122** color LEDs.

As shown in FIG. 3, the reflector **106** includes a first end, or input end **124**, adjacent the light source **104** and a second end, or output end **126**, opposite the input end **124**. As is best shown in FIG. 6, the reflector **106** is tapered such that the reflector **106** is narrower at the input end **124** than at the output end **126**. Stated another way, the reflector **106** includes an output end **126** that is wider than the input end **124**. At the input end **124** of the reflector **106**, the width is about the same as a corresponding width of the array **114** of LEDs to reduce or eliminate any gaps between the array **114** and the sidewall(s) of the reflector **106**. The light source **104** emits light through the reflector **106** from the input end **124** through the output end **126** in a direction along an optical axis **127** of the lighting fixture **100**. As shown in FIGS. 8 and 9, the reflector **106** has a hexagonal cross-sectional shape formed by six side walls. Other embodiments of the lighting fixture **100** may include a reflector **106** of a different shape, such as a reflector **106b** having a rectangular cross-sectional shape (shown in FIGS. 10 and 11), or the like.

As shown in FIG. 6, the lighting fixture **100** further includes a tandem lens array **128** adjacent the output end **126** of the reflector **106**. In some embodiments, the tandem lens array **128** is positioned within the output end **126** of the reflector **106**. The tandem lens array **128** is also disposed within the housing **102** of the lighting fixture **100**. With particular reference to FIG. 12, the tandem lens array **128** is shown as a hexagonal tandem lens array to generally match or correspond to the cross-sectional shape of the output end **126** of the hexagonal reflector **106**. In other embodiments, a reflector **106** having another cross-sectional shape may be used. In such embodiments, the tandem lens array **128** can match or correspond to the cross-sectional shape of the reflector **106**. Generally, all or substantially all of the light emitted from the reflector **106** passes through the tandem lens array **128**. The tandem lens array **128** enhances color mixing and is particularly suited for use in a wash beam type lighting fixture **100**.

As shown in FIGS. 12 and 13, in some embodiments, the tandem lens array **128** is a single substrate that includes a first side **130** that faces toward the light source **104** and a second side **132** that is opposite the first side **130**. Each of the first side **130** and the second side **132** includes an array of approximately semi-sphere shaped lenses **134**. The lenses

134 are approximately semi-sphere shaped because the lenses **134** have an F-number that is about 1.159 in the illustrated embodiment, where an F-number of 1.0 would correspond to lenses that are an exact or precise semi-sphere shape. In other embodiments, the pattern of lenses **134** may be randomized rather than repeating. The tandem lens array **128** breaks up the light after it has been mixed and collimated in the reflector **106** into multiple overlapping beams, or Kohler illuminators, which further mixes the light to a better uniformity. In the illustrated embodiment, each lens **134** on the first side **130** is paired with a corresponding lenses **134** on the second side **132** with a common axis **135** that extends centrally through the paired lenses **134**. A lens pair **134a** and **134b** from the first and second sides **130**, **132**, respectively, are labeled in FIG. 13 having the common axis **135**. In other embodiments, the tandem lens array **128** includes lenses **134** arranged in a circular pattern around a center of the tandem lens array **128**. In some embodiments, the tandem lens array **128** includes lenses **134** that have a randomly shaped arrangement.

As shown in FIG. 3, the lighting fixture **100** further includes a shutter system **108**. An exploded view of the shutter system **108** is shown in FIG. 14. The shutter system **108** includes a plurality of shutter blades **136**. In the illustrated embodiment, each of the shutter blades **136** is disposed entirely within the housing **102** and between the tandem lens array **128** and the outlet **103** of the housing **102**. In some embodiments, only a portion of each of the shutter blades **136** may be within the housing **102** with at least a portion of the shutter blades **136** extending through the housing **102** and being disposed outside of the housing **102**. In the illustrated embodiment, the shutter blades **136** are disposed adjacent the tandem lens array **128**. The illustrated shutter system **108** includes four shutter guide plates **138**. Each shutter guide plate **138** includes at least one shutter blade **136**. The at least one shutter blade **136** of each guide plate **138** translates relative to the shutter guide plate **138**. Each shutter blade **136** is radially adjustable in a direction that is perpendicular to the optical axis **127**. In the illustrated embodiment, each shutter blade **136** slides relative to the corresponding shutter guide plate **138**.

As shown in FIG. 15, the lighting fixture **100** includes a motor **140** associated with each of the shutter guide plates **138** and the corresponding shutter blade **136**. Each motor **140** rotates a corresponding cam **142** to engage a follower **144** coupled to the corresponding shutter blade **136**. Rotation of the cam **142** pushes the follower **144** such that the shutter blade **136** moves radially toward the optical axis **127**. As the cam **142** rotates further, or rotates in the opposite direction, the shutter blade **136** moves away from the optical axis **127** by, for instance, a bias. Stated another way, a spring or other resilient member urges the shutter blade **136** radially outward relative to the optical axis **127**.

As shown in FIGS. 3 and 4, the shutter system **108** is rigidly connected to the reflector **106** and a cylindrical frame member **146** with fasteners **148**. Shown particularly in FIG. 4, a shutter system rotation motor **150** rotates a belt **152**, which, in turn, rotates the cylindrical frame member **146**. Due to the rigid connections, operation of the shutter system rotation motor **150** causes the shutter guide plates **138** and the corresponding shutter blades **136** to rotate about the optical axis **127**. This rotation allows the shutter blades **136** to move to different positions about the optical axis **127** to alter the shape of the light permitted to travel along the optical axis **127**. Shown particularly in FIG. 3, the shutter system **108** is supported by multiple rollers **154**, which

5

maintain the components of the lighting fixture 100 in place laterally as the components rotate about the optical axis 127.

With reference to FIG. 4, the lighting fixture 100 further includes the condenser 110 disposed along the optical axis 127 between the shutter system 108 and the outlet 103 of the housing 102. In the illustrated embodiment shown in FIGS. 5 and 6, the condenser 110 includes a first condenser lens 158 and a second condenser lens 160. At least one of the first condenser lens 158 and the second condenser lens 160 may be an aspheric lens. In the illustrated embodiment, the first condenser lens 158 is an aspheric lens and the second condenser lens 160 is a spherical lens. The first condenser lens 158 is disposed nearer to the shutter system 108 than the second condenser lens 160. The second condenser lens 160 is positioned along the optical axis 127 between the first condenser lens 158 and the outlet 103 of the housing 102. In the illustrated embodiment, the first condenser lens 158 includes a first curved side 162 that faces toward the light source 104 and a first flat side 164 that is opposite the first curved side 162. The second condenser lens 160 includes a second curved side 166 that faces toward the light source 104 and a second flat side 168 that is opposite the second curved side 166. Both the first condenser lens 158 and the second condenser lens 160 are coupled to the cylindrical frame member 146 such that the first condenser lens 158 and the second condenser lens 160 are axially fixed relative to the tandem lens array 128 and will rotate with the shutter system 108.

As shown in FIGS. 4-6, the lighting fixture 100 also includes a Fresnel lens 170. The Fresnel lens 170 is disposed along the optical axis 127 between the condenser 110 and the outlet 103 of the housing 102. With reference to FIGS. 5 and 6, the light source 104, the reflector 106, the tandem lens array 128, the shutter system 108, the condenser 110, and the Fresnel lens 170 are all aligned along the optical axis 127, which extends longitudinally through the lighting fixture 100. The Fresnel lens 170 is movable along the optical axis 127 to alter the beam angle of the light traveling through and exiting the lighting fixture 100. Because the light source 104, the reflector 106, the tandem lens array 128, the shutter system 108, and the condenser 110 are all axially stationary relative to each other along the optical axis 127, the Fresnel lens 170 moves axially relative to these components of the lighting fixture 100.

In the illustrated embodiment, the light source 104, the reflector 106, the tandem lens array 128, the shutter system 108, the condenser 110, and the Fresnel lens 170 are all wholly disposed within the housing 102 of the lighting fixture 100.

Thus, embodiments described herein provide a lighting fixture having a shutter blade at least partially disposed within the housing of the lighting fixture.

What is claimed is:

1. A lighting fixture comprising:

a housing including an outlet through which light passes; an optical axis extending centrally through the outlet;

a light source including an array of light-emitting diodes (LEDs) disposed within the housing;

a reflector including

an input end positioned along the optical axis between the light source and the outlet of the housing, and an output end positioned along the optical axis between the input end and the outlet of the housing, such that the light source emits light through the reflector from the input end through the output end;

6

a tandem lens array positioned along the optical axis between the output end of the reflector and the outlet of the housing;

a shutter blade positioned along the optical axis between the tandem lens array and the outlet of the housing, the shutter blade disposed at least partially within the housing; and

a condenser positioned along the optical axis between the shutter blade and the outlet of the housing, the condenser including a lens.

2. The lighting fixture of claim 1, wherein the lens includes an aspheric lens.

3. The lighting fixture of claim 2, wherein the condenser further includes a second lens positioned along the optical axis between the aspheric lens and the outlet of the housing.

4. The lighting fixture of claim 3, wherein the second lens includes a spherical lens.

5. The lighting fixture of claim 3, wherein each of the aspheric lens and the second lens includes a curved side that faces toward the light source and a flat side that is opposite the curved side.

6. The lighting fixture of claim 1, wherein the tandem lens array includes a first side that faces toward the light source and a second side that is opposite the first side, the first side includes an array of lenses, and the second side includes an array of lenses.

7. The lighting fixture of claim 1, wherein the reflector includes a tapered reflector being narrower at the input end than the output end.

8. The lighting fixture of claim 7, wherein the reflector has a hexagonal cross-section.

9. The lighting fixture of claim 1, wherein the shutter blade is adjacent the tandem lens array.

10. The lighting fixture of claim 1, wherein the condenser is in an axially fixed position relative to the tandem lens array.

11. The lighting fixture of claim 1, further comprising a Fresnel lens positioned along the optical axis between the condenser and the outlet of the housing.

12. The lighting fixture of claim 10, wherein the Fresnel lens moves relative to the condenser along the optical axis.

13. The lighting fixture of claim 1, wherein the array of LEDs includes two different color LEDs, and the arrangement of the LEDs is radially asymmetrical with regard to color.

14. The lighting fixture of claim 13, wherein each color of LEDs is arranged in a straight strip of LEDs.

15. A lighting fixture comprising:

a housing;

a light source including an array of light-emitting diodes (LEDs) disposed within the housing;

a tapered reflector disposed within the housing, the tapered reflector including

an input end adjacent the light source,

an output end opposite the input end, the output end being wider than the input end, and

wherein the light source emits light through the tapered reflector from the input end through the output end;

a tandem lens array adjacent the output end of the reflector, the tandem lens array disposed within the housing and including

a first side facing toward the light source, the first side including an array of lenses, and

a second side opposite the first side, the second side including an array of lenses;

a shutter blade adjacent the second side of the tandem lens array, the shutter blade disposed at least partially within the housing; and

a condenser adjacent the shutter blade, the condenser including two condenser lenses disposed within the housing. 5

16. The lighting fixture of claim **15**, wherein the light source, the tapered reflector, the tandem lens array, the shutter blade, and the condenser lenses are all aligned along an optical axis extending longitudinally through the lighting fixture. 10

17. The lighting fixture of claim **16**, further comprising a Fresnel lens disposed adjacent the condenser and aligned along the optical axis, the Fresnel lens adjustable along the optical axis. 15

18. The lighting fixture of claim **17**, wherein the light source, the tapered reflector, the tandem lens array, the shutter blade, and the condenser lenses are stationary relative to each other along the optical axis.

19. The lighting fixture of claim **18**, wherein the shutter blade is adjustable in a direction perpendicular to the optical axis. 20

20. The lighting fixture of claim **15**, wherein the shutter blade is disposed completely within the housing.

* * * * *