



US010520175B2

(12) **United States Patent**  
**Jurik et al.**

(10) **Patent No.:** **US 10,520,175 B2**  
(45) **Date of Patent:** **Dec. 31, 2019**

(54) **COLLIMATION AND HOMOGENIZATION SYSTEM FOR AN LED LUMINAIRE**

(71) Applicant: **Robe Lighting s.r.o.**, Roznov pod Radhostem (CZ)

(72) Inventors: **Pavel Jurik**, Prostredni Becva (CZ); **Josef Valchar**, Prostredni Becva (CZ)

(73) Assignee: **Robe Lighting s.r.o.**, Roznov pod Radhostem (CZ)

(\*) Notice: Subject to any disclaimer, the term of this patent is extended or adjusted under 35 U.S.C. 154(b) by 0 days.

(21) Appl. No.: **15/026,889**

(22) PCT Filed: **Oct. 1, 2014**

(86) PCT No.: **PCT/US2014/058682**

§ 371 (c)(1),

(2) Date: **Apr. 1, 2016**

(87) PCT Pub. No.: **WO2015/051031**

PCT Pub. Date: **Apr. 9, 2015**

(65) **Prior Publication Data**

US 2016/0290597 A1 Oct. 6, 2016

(51) **Int. Cl.**

**F21V 21/15** (2006.01)

**F21V 14/08** (2006.01)

(Continued)

(52) **U.S. Cl.**

CPC ..... **F21V 21/15** (2013.01); **F21K 9/62** (2016.08); **F21S 10/007** (2013.01); **F21V 5/008** (2013.01);

(Continued)

(58) **Field of Classification Search**

CPC ..... **F21V 7/0091**; **F21V 5/008**; **F21V 11/186**; **F21V 14/06**; **F21S 10/007**; **F21W 2131/406**

See application file for complete search history.

(56) **References Cited**

U.S. PATENT DOCUMENTS

4,151,584 A 4/1979 Labrum  
5,188,452 A 2/1993 Ryan

(Continued)

FOREIGN PATENT DOCUMENTS

CN 2062838 U 9/1990  
CN 1172762 A 2/1998

(Continued)

OTHER PUBLICATIONS

Jurik, Pavel, et al.; U.S. Appl. No. 15/516,397, filed Apr. 1, 2017; Title: Collimation and Homogenization System for an LED Luminaire; 46 pages.

(Continued)

*Primary Examiner* — Sharon E Payne

(74) *Attorney, Agent, or Firm* — Conley Rose, P.C.; Grant Rodolph; Brooks W Taylor

(57) **ABSTRACT**

Disclosed is an LED light source automated luminaire with a multi sided elongated light collimator/mixer/integrator with receiving lens and output lens both with spill shields and where the receiving spill shield is nesting in the output spill shield. The elongated integrator has a square input cross-section and a hexagon or octagon output cross section and is tapered so that the input cross section is smaller than the output cross section.

**19 Claims, 23 Drawing Sheets**

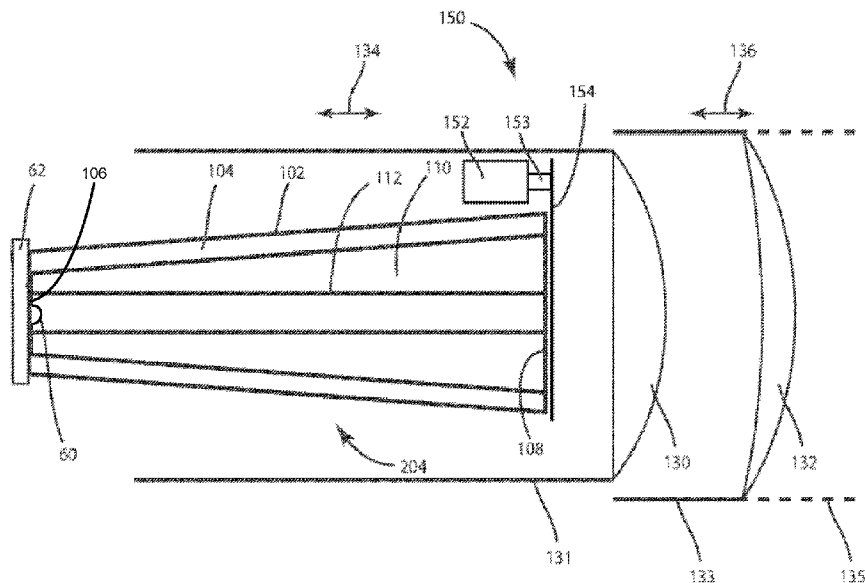

(51) **Int. Cl.**

**F21V 8/00** (2006.01)  
**F21K 9/62** (2016.01)  
**F21V 14/06** (2006.01)  
**F21V 5/00** (2018.01)  
**G02B 19/00** (2006.01)  
**G02B 27/00** (2006.01)  
**F21V 11/18** (2006.01)  
**F21S 10/00** (2006.01)  
**F21V 7/00** (2006.01)  
**G02B 6/00** (2006.01)  
**G02B 27/09** (2006.01)  
**F21V 5/04** (2006.01)  
**F21V 9/08** (2018.01)  
**F21Y 105/10** (2016.01)  
**F21Y 115/10** (2016.01)  
**F21Y 113/13** (2016.01)  
**F21W 131/406** (2006.01)  
**F21Y 101/00** (2016.01)

FOREIGN PATENT DOCUMENTS

CN	1194369	A	9/1998	
CN	1349877	A	5/2002	
CN	2589551	Y	12/2003	
CN	1854598	A	11/2006	
CN	102959326	A	3/2013	
CN	103270437	A	8/2013	
EP	1710495	B1 *	7/2012	..... F21S 8/00
EP	2590044	A1	5/2013	
EP	2770251	A1	8/2014	
JP	2006162878	A	6/2006	
JP	2012084298	A	4/2012	
WO	03079532	A2	9/2003	
WO	WO 2012004760	A1 *	1/2012	..... F21V 5/008
WO	2012083957	A1	6/2012	
WO	2013098387	A2	7/2013	
WO	2014031641	A2	2/2014	

(52) **U.S. Cl.**

CPC ..... **F21V 5/04** (2013.01); **F21V 7/0091** (2013.01); **F21V 9/08** (2013.01); **F21V 11/186** (2013.01); **F21V 14/06** (2013.01); **F21V 14/08** (2013.01); **G02B 6/00** (2013.01); **G02B 6/0008** (2013.01); **G02B 19/0028** (2013.01); **G02B 19/0066** (2013.01); **G02B 27/0018** (2013.01); **G02B 27/0927** (2013.01); **G02B 27/0994** (2013.01); **F21W 2131/406** (2013.01); **F21Y 2101/00** (2013.01); **F21Y 2105/10** (2016.08); **F21Y 2113/13** (2016.08); **F21Y 2115/10** (2016.08)

OTHER PUBLICATIONS

PCT International Search Report; Application No. PCT/US2014/058682, dated Jul. 20, 2015; 5 pages.  
 PCT Written Opinion of the International Searching Authority; Application No. PCT/US2014/058682; dated Jul. 20, 2015; 6 pages.  
 PCT International Search Report; Application No. PCT/US2014/058688; dated Mar. 12, 2015; 3 pages.  
 PCT Written Opinion of the International Searching Authority; Application No. PCT/US2014/058688; dated Mar. 12, 2015; 6 pages.  
 PCT International Search Report; Application No. PCT/US2015/053557; dated Mar. 15, 2016; 5 pages.  
 PCT Written Opinion of the International Searching Authority; Application No. PCT/2015/053557; dated Mar. 15, 2016; 7 pages.  
 European Examination Report; Application No. 14824174.8; dated Jan. 5, 2018; 5 pages.  
 Office Action dated Mar. 9, 2018; U.S. Appl. No. 15/125,162, filed Sep. 10, 2016; 16 pages.  
 Notice of Allowance dated Aug. 8, 2018; U.S. Appl. No. 15/125,162, filed Sep. 10, 2016; 23 pages.  
 Office Action dated May 24, 2018; U.S. Appl. No. 15/516,397, filed Apr. 1, 2017; 16 pages.  
 PCT International Search Report; Application No. PCT/US2015/019746; dated Dec. 1, 2015; 4 pages.  
 PCT Written Opinion of the International Searching Authority; Application No. PCT/US2015/019746; dated Dec. 1, 2015; 8 pages.  
 Chinese Office Action; Application No. 201480065736.5; dated May 28, 2018; 13 pages.  
 Chinese Office Action; Application No. 201480065732.7; dated Jun. 5, 2018; 11 pages.  
 European Examination Report; Application No. 15825876.4; dated May 29, 2018; 5 pages.  
 Notice of Allowance dated Oct. 3, 2018; U.S. Appl. No. 15/516,397, filed Apr. 1, 2017; 14 pages.  
 European Examination Report; Application No. 14821902.5; dated Apr. 23, 2019; 4 pages.  
 Chinese Office Action; Application No. 201480065732.7; dated Apr. 15, 2019; 13 pages.  
 Chinese Office Action; Application No. 201480065736.5; dated Feb. 19, 2019; 9 pages.  
 European Examination Report; Application No. 15825876.4; dated Sep. 3, 2019; 5 pages.

(56)

**References Cited**

U.S. PATENT DOCUMENTS

5,227,931	A	7/1993	Misumi	
5,374,883	A	12/1994	Morser	
5,406,176	A	4/1995	Sugden	
5,764,018	A	6/1998	Liepe et al.	
5,955,855	A	9/1999	Van Ochten et al.	
6,580,244	B2	6/2003	Tanaka et al.	
9,632,035	B2 *	4/2017	Brucilacchio	..... G01N 21/8806
2001/0007527	A1	7/2001	Lammers et al.	
2004/0135534	A1	7/2004	Cullen	
2008/0137345	A1	6/2008	Wimberly	
2009/0231854	A1	9/2009	Jurik	
2009/0231864	A1 *	9/2009	Polasek	..... G05B 19/404 362/418
2011/0063847	A1 *	3/2011	Quadri	..... F21V 11/10 362/284
2011/0249442	A1 *	10/2011	Jurik	..... F21S 10/007 362/277
2013/0162172	A1	6/2013	Baaijens et al.	
2014/0025195	A1	1/2014	Ahmadpour	
2014/0301071	A1 *	10/2014	Jorgensen	..... F21V 14/06 362/231
2015/0230320	A1	8/2015	Gritti et al.	
2015/0308663	A1 *	10/2015	Jurik	..... F21S 10/007 362/277
2016/0299489	A1	10/2016	Junk et al.	
2017/0016595	A1	1/2017	Kubis et al.	

\* cited by examiner

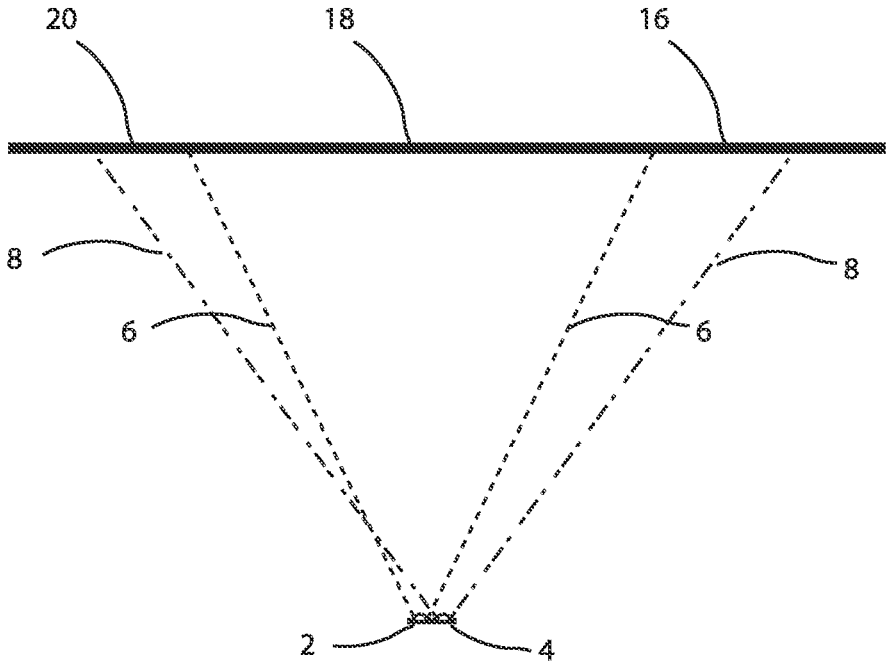

(Prior art)

FIG 1

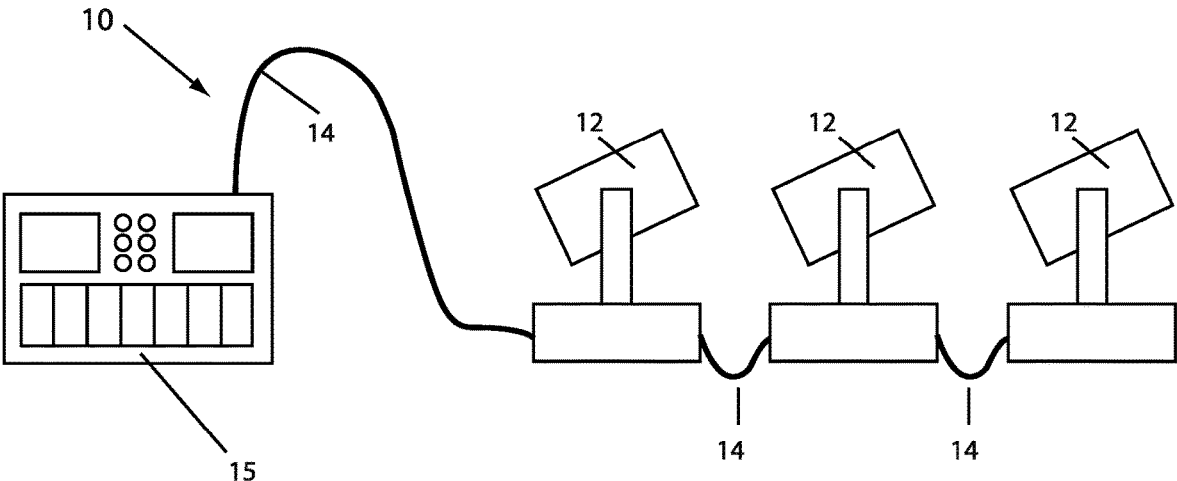

FIG 2

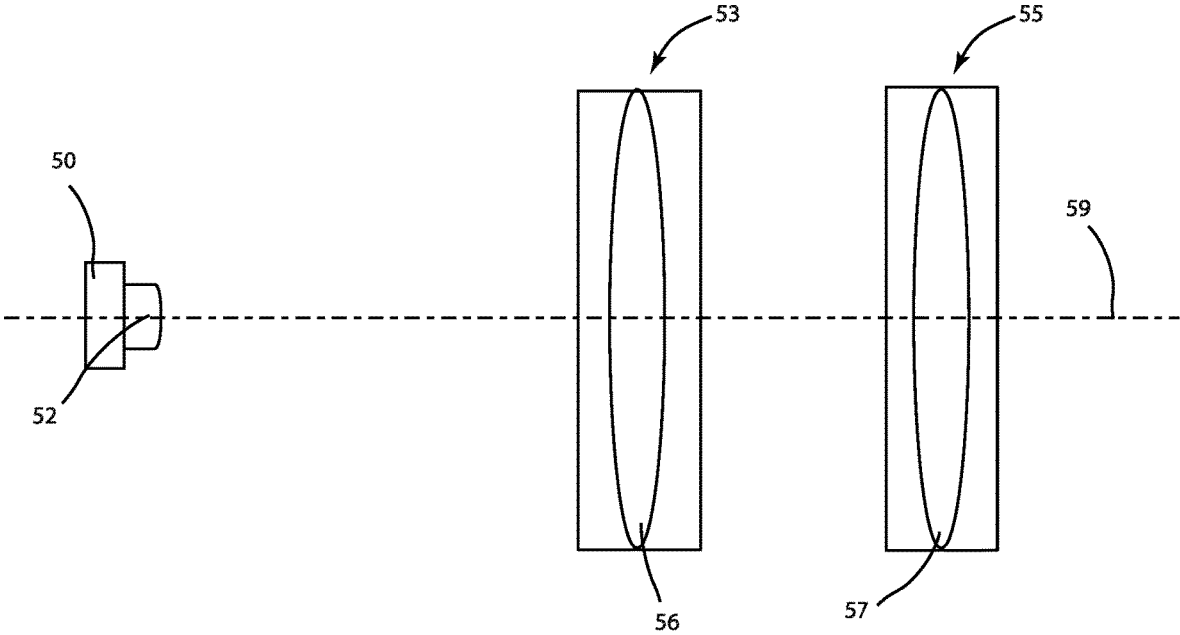

FIG 3

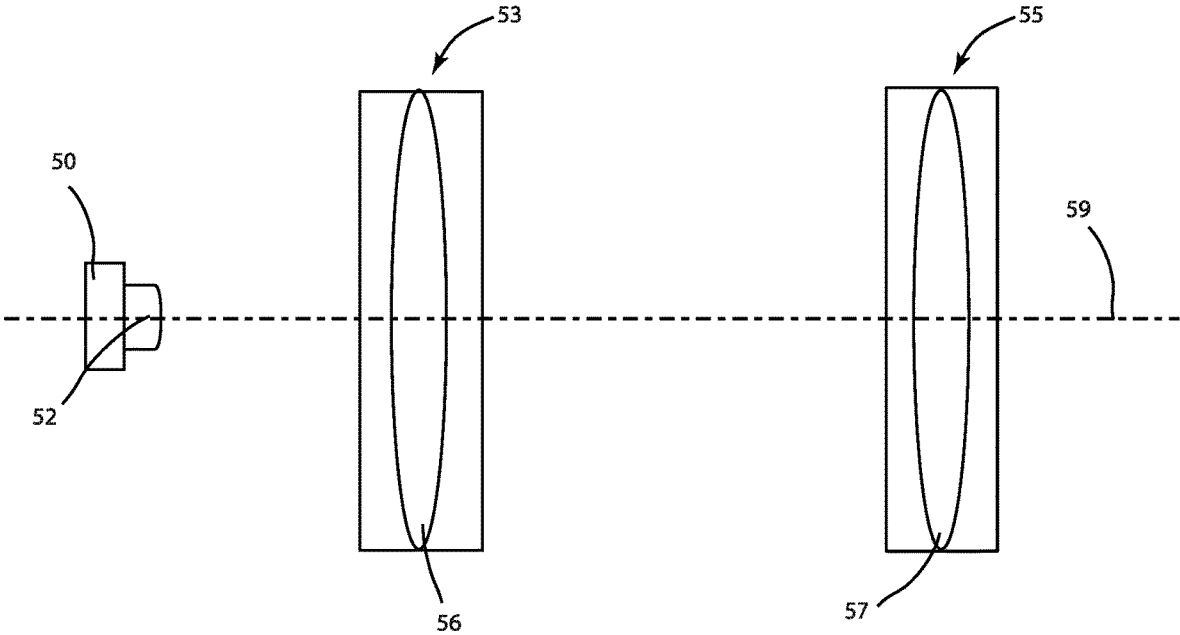

FIG 4

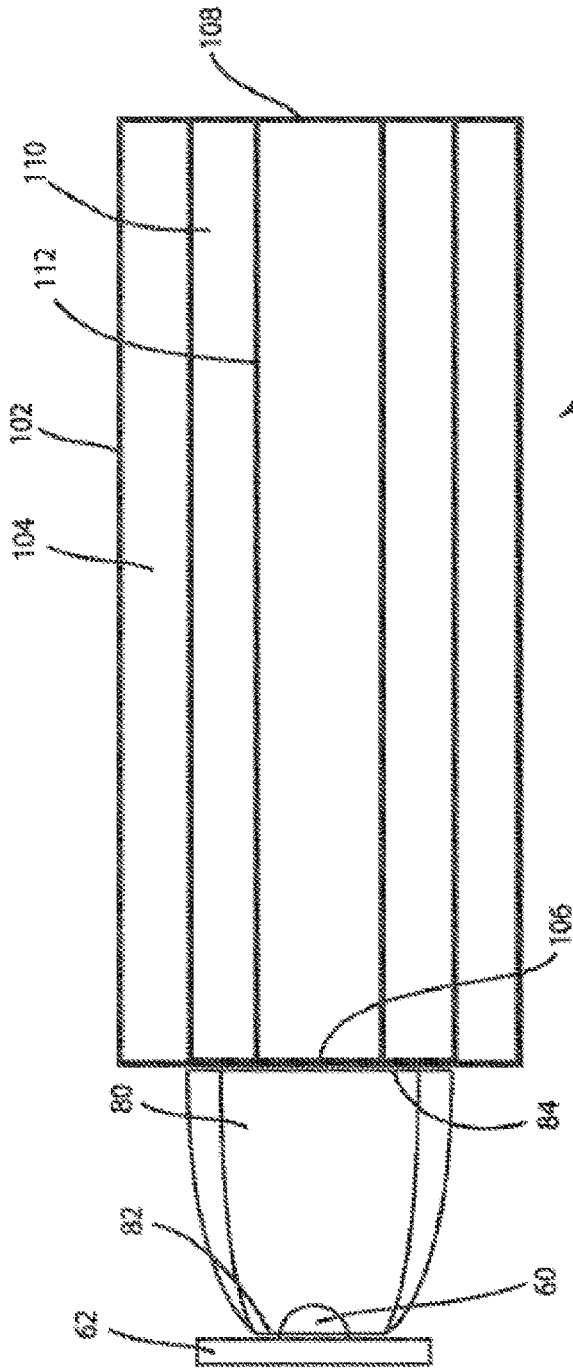

FIG 5

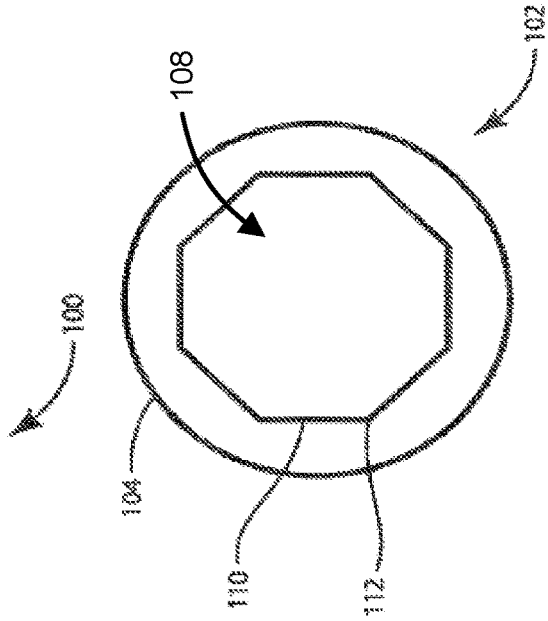

FIG 6

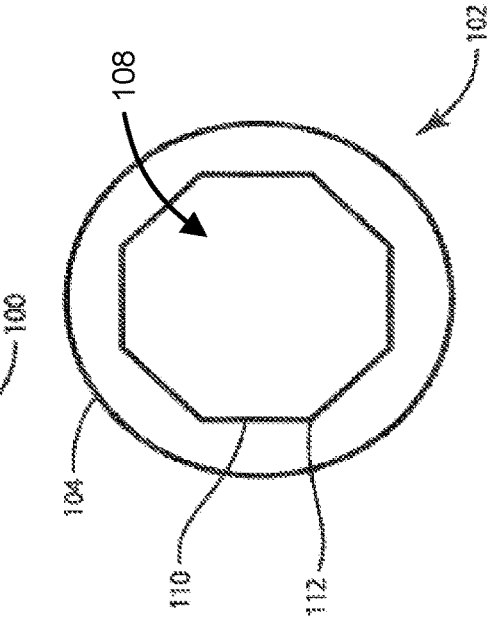

FIG 7

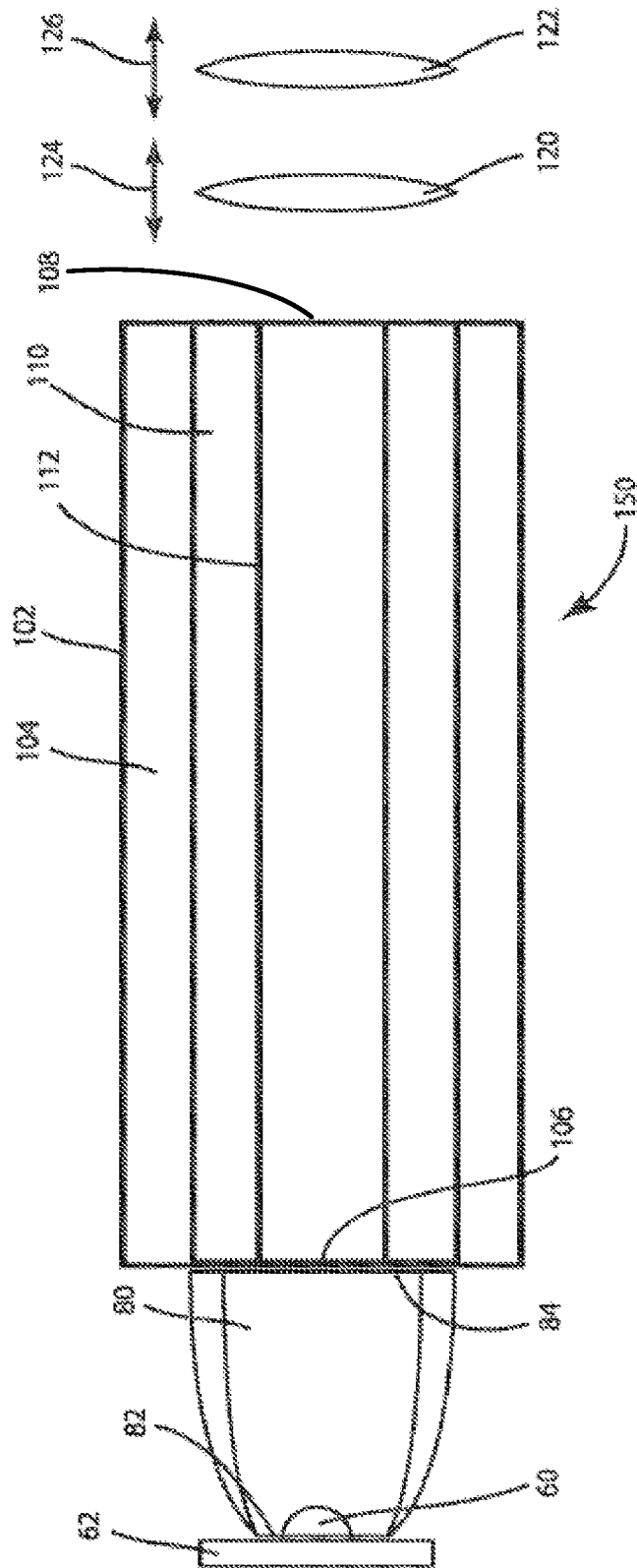
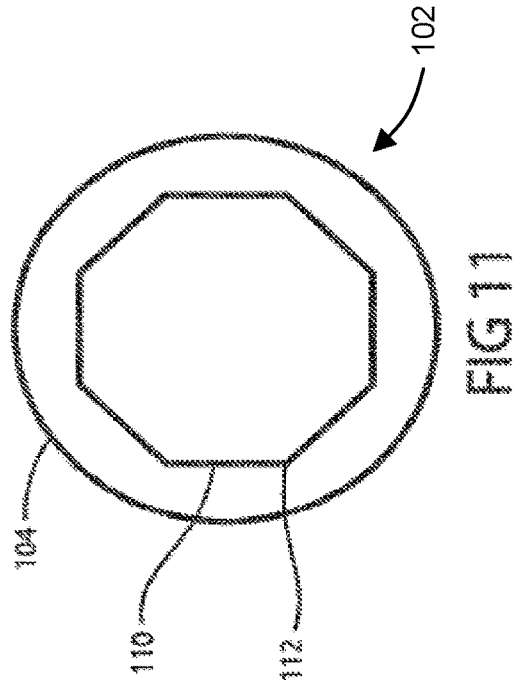
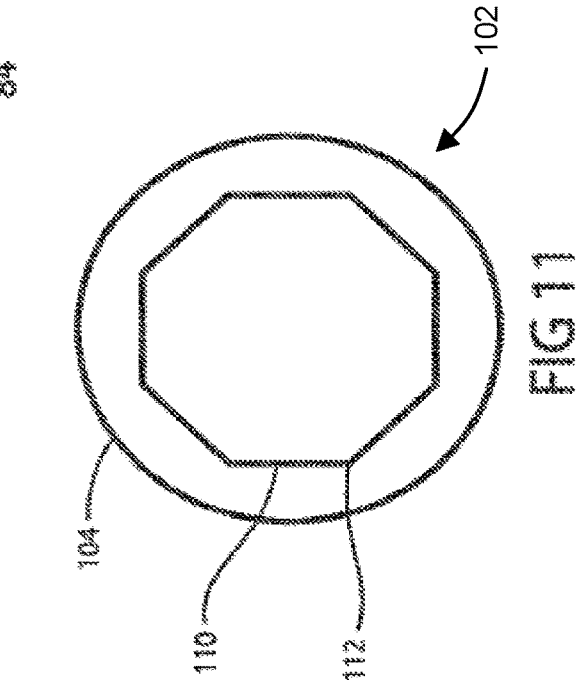
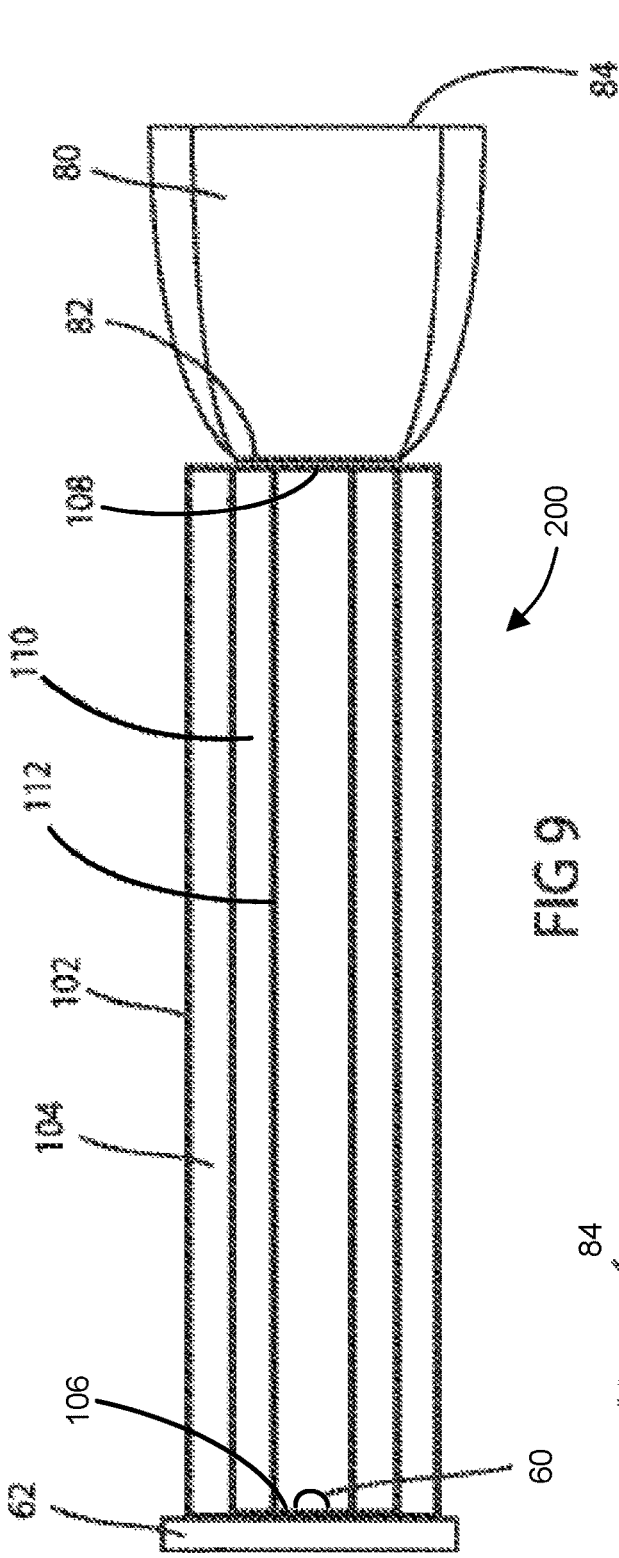

FIG 8



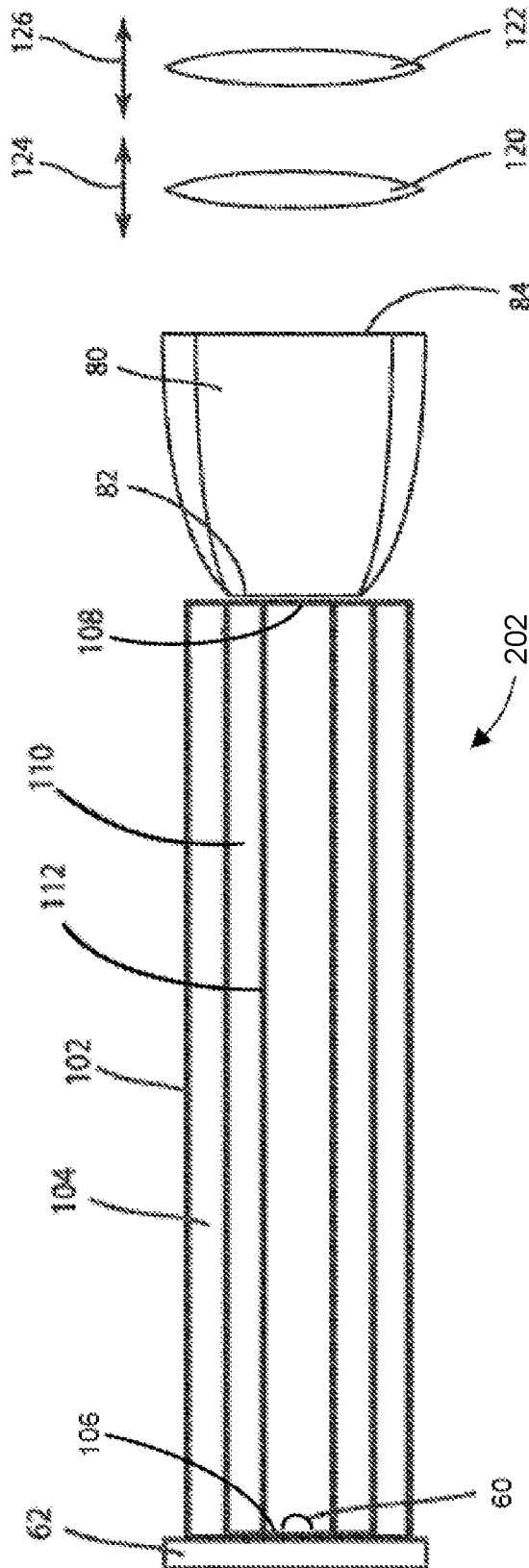

FIG 12

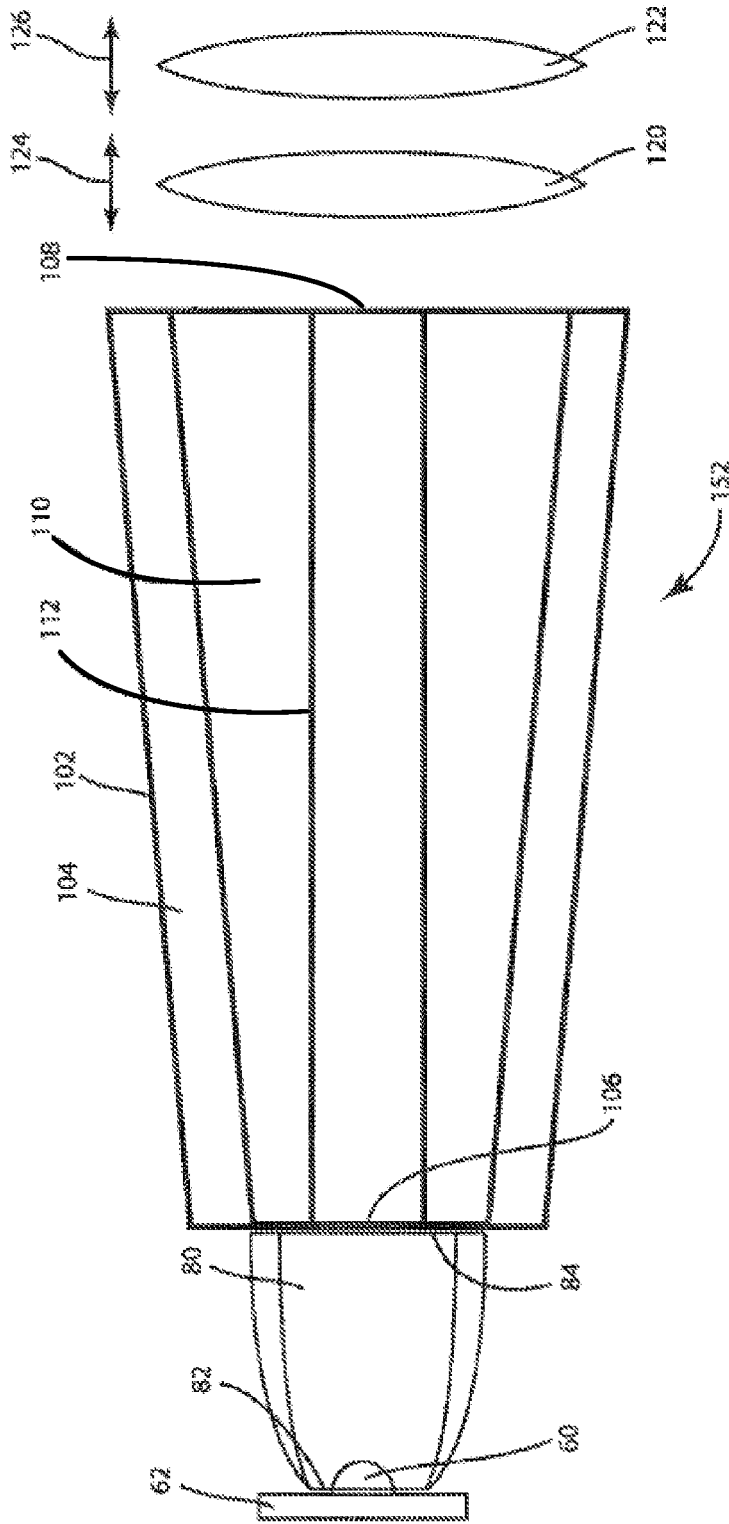

FIG 13

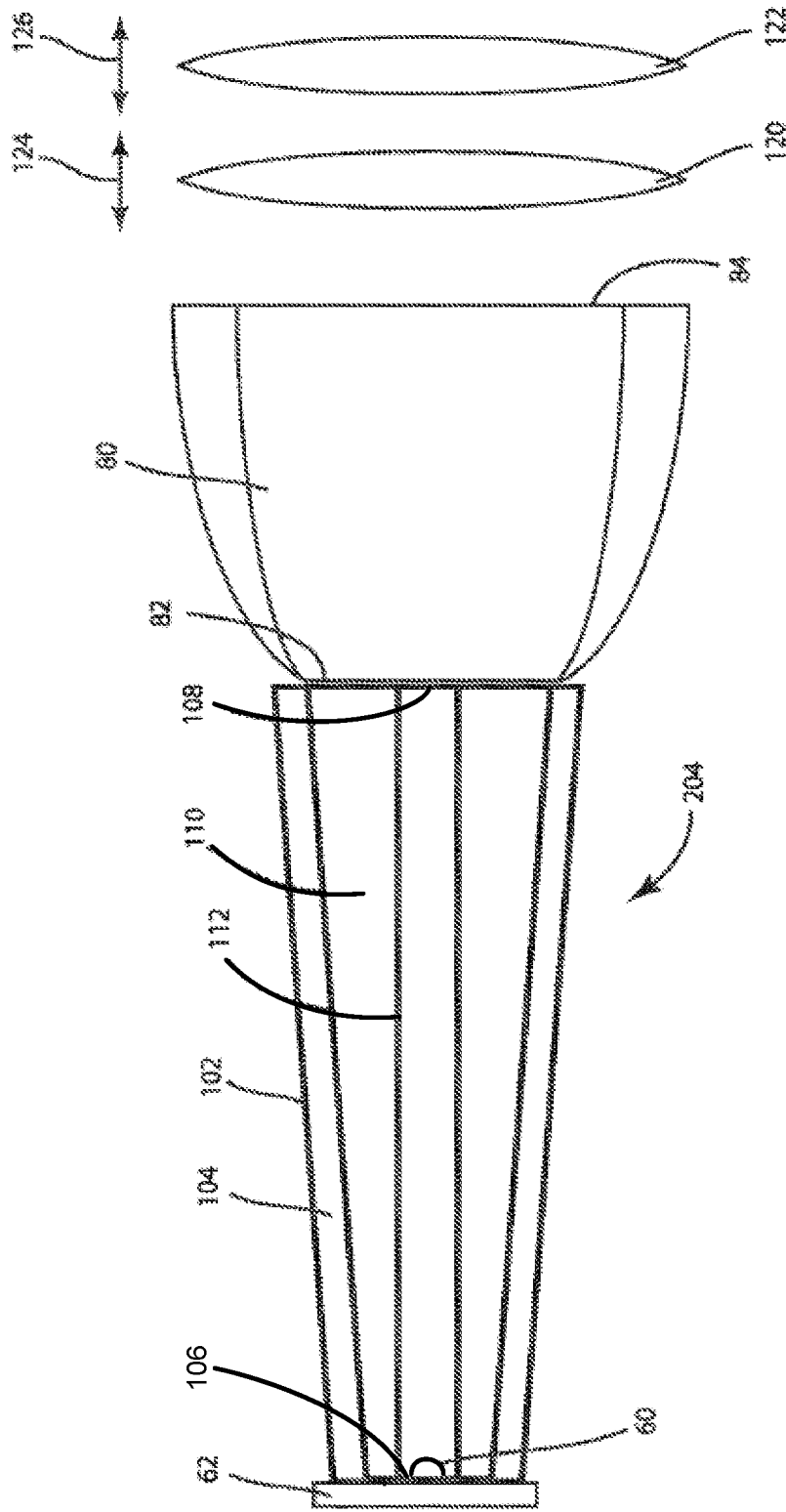

FIG 14

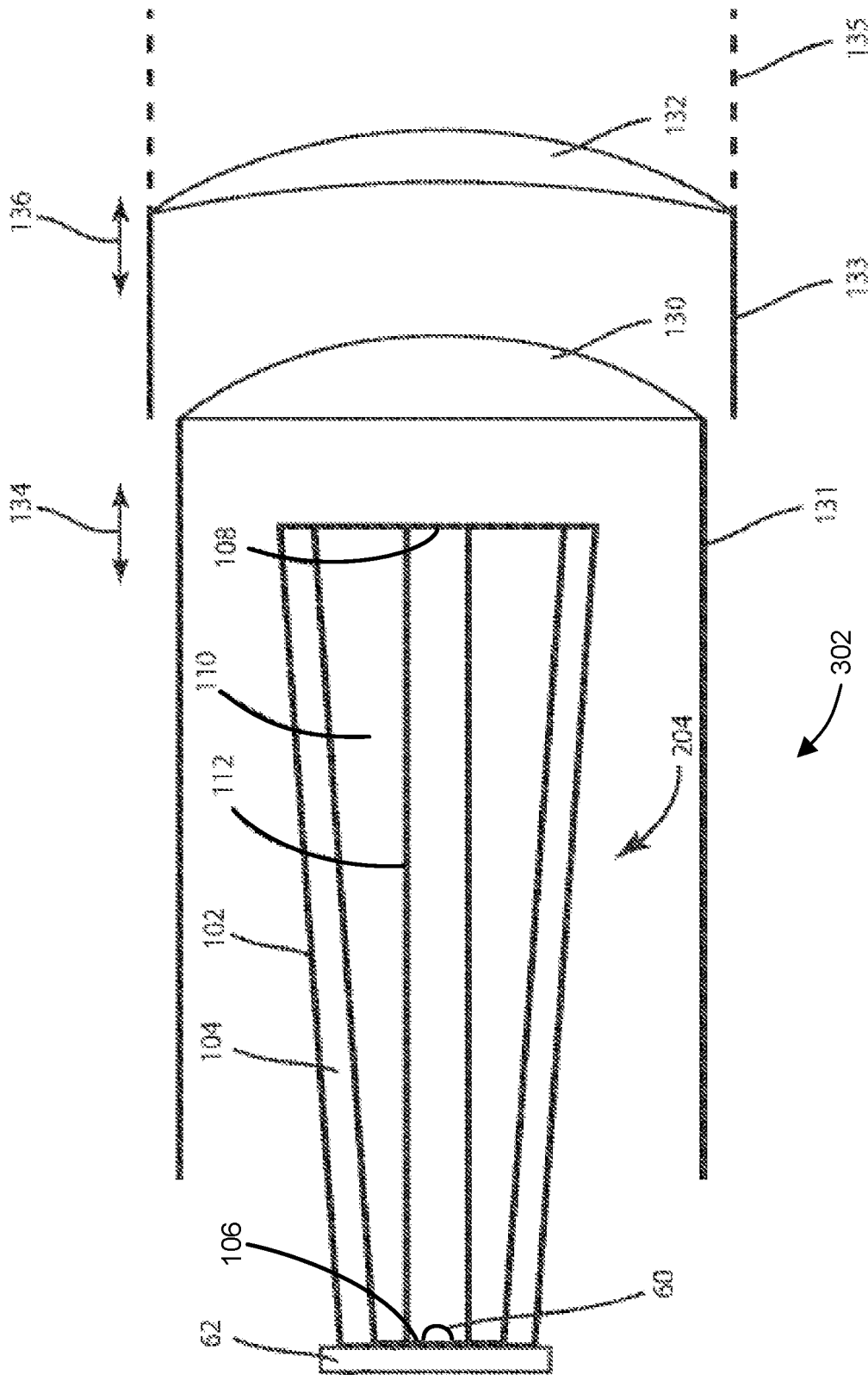

FIG 15

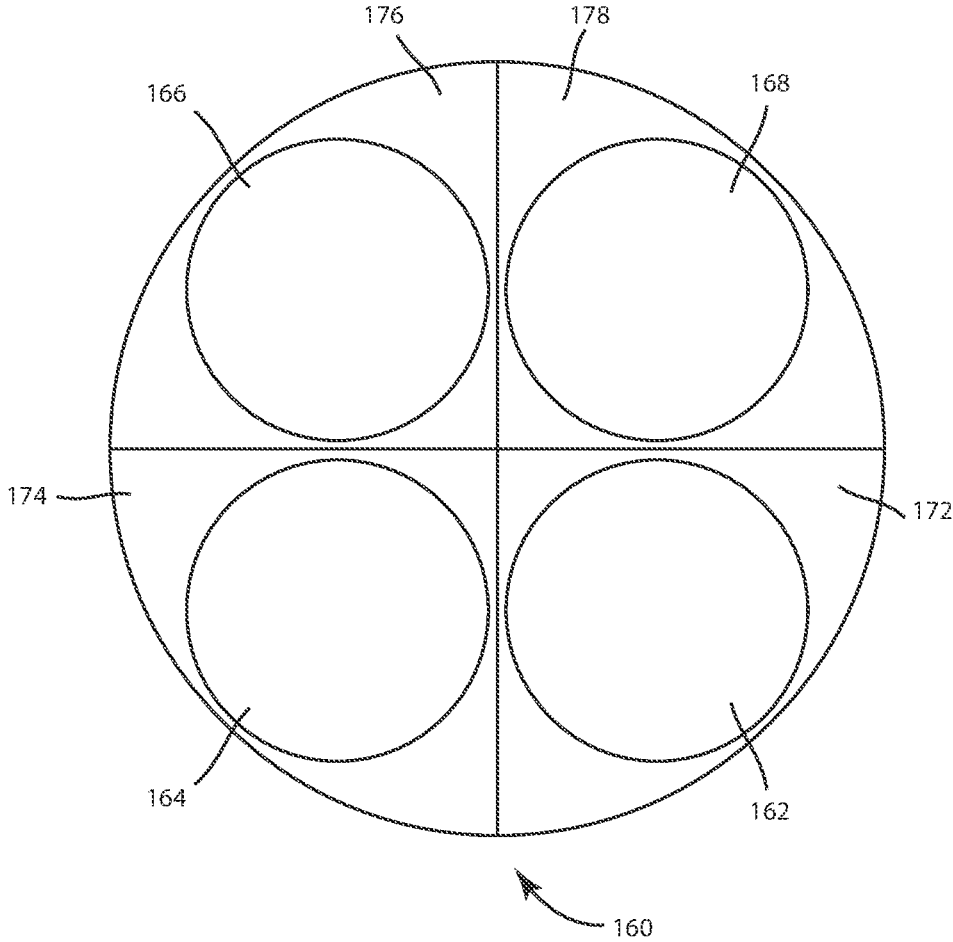

FIG 16

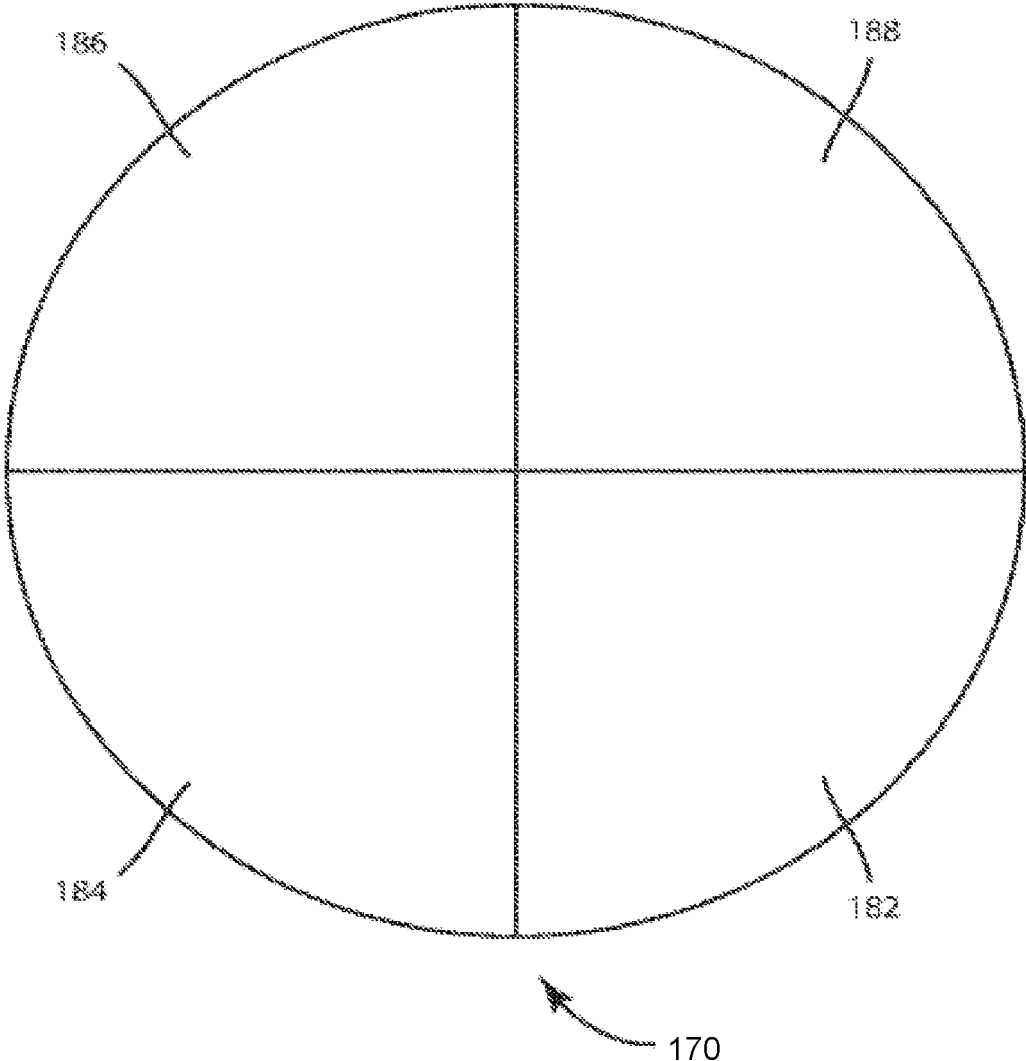

FIG 17

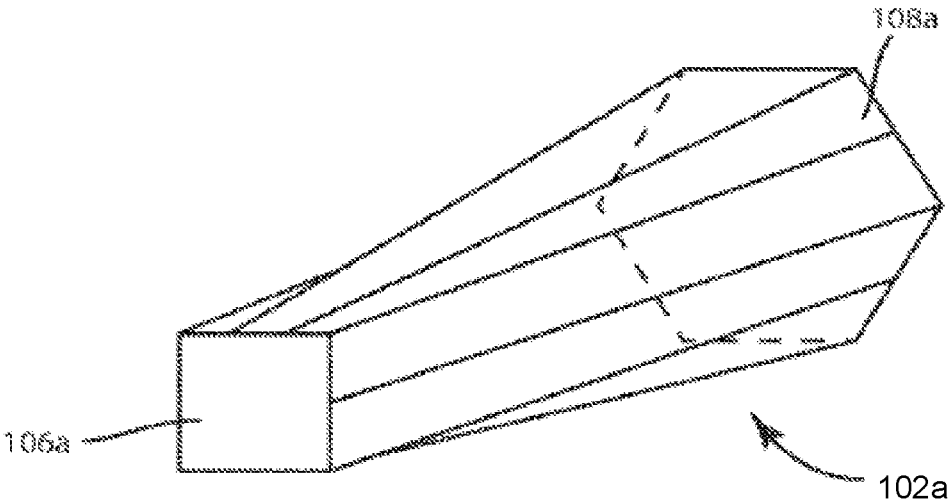

FIG 18

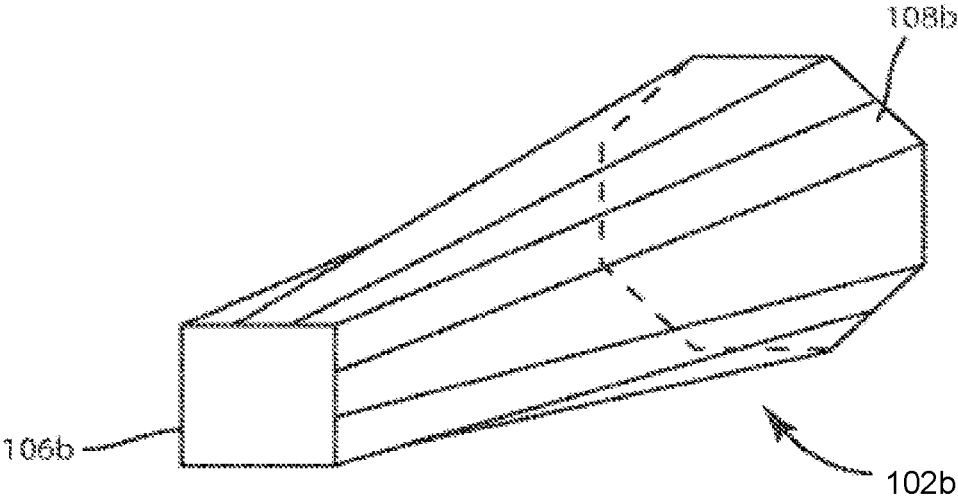

FIG 19



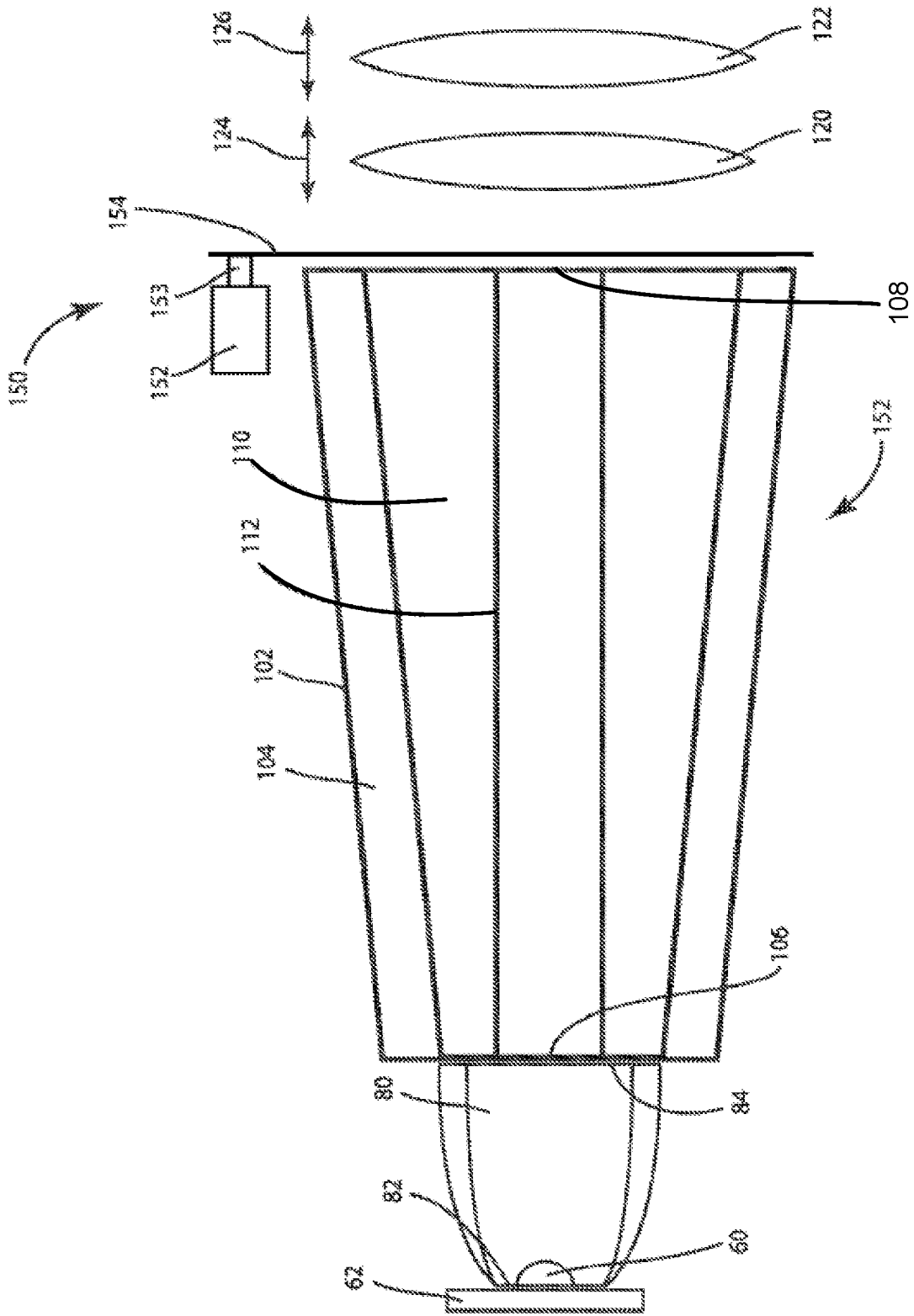

FIG 21

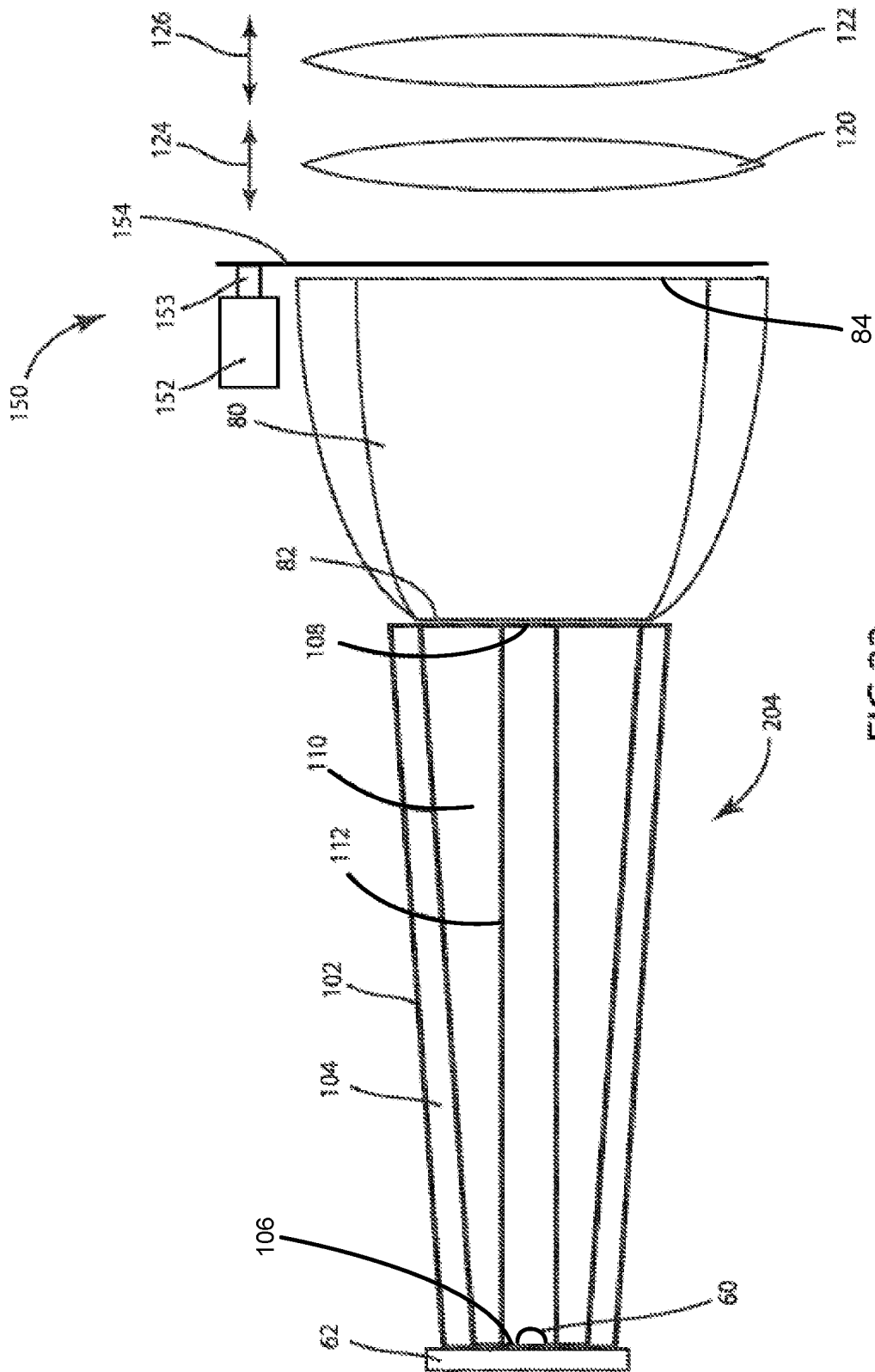

FIG 22

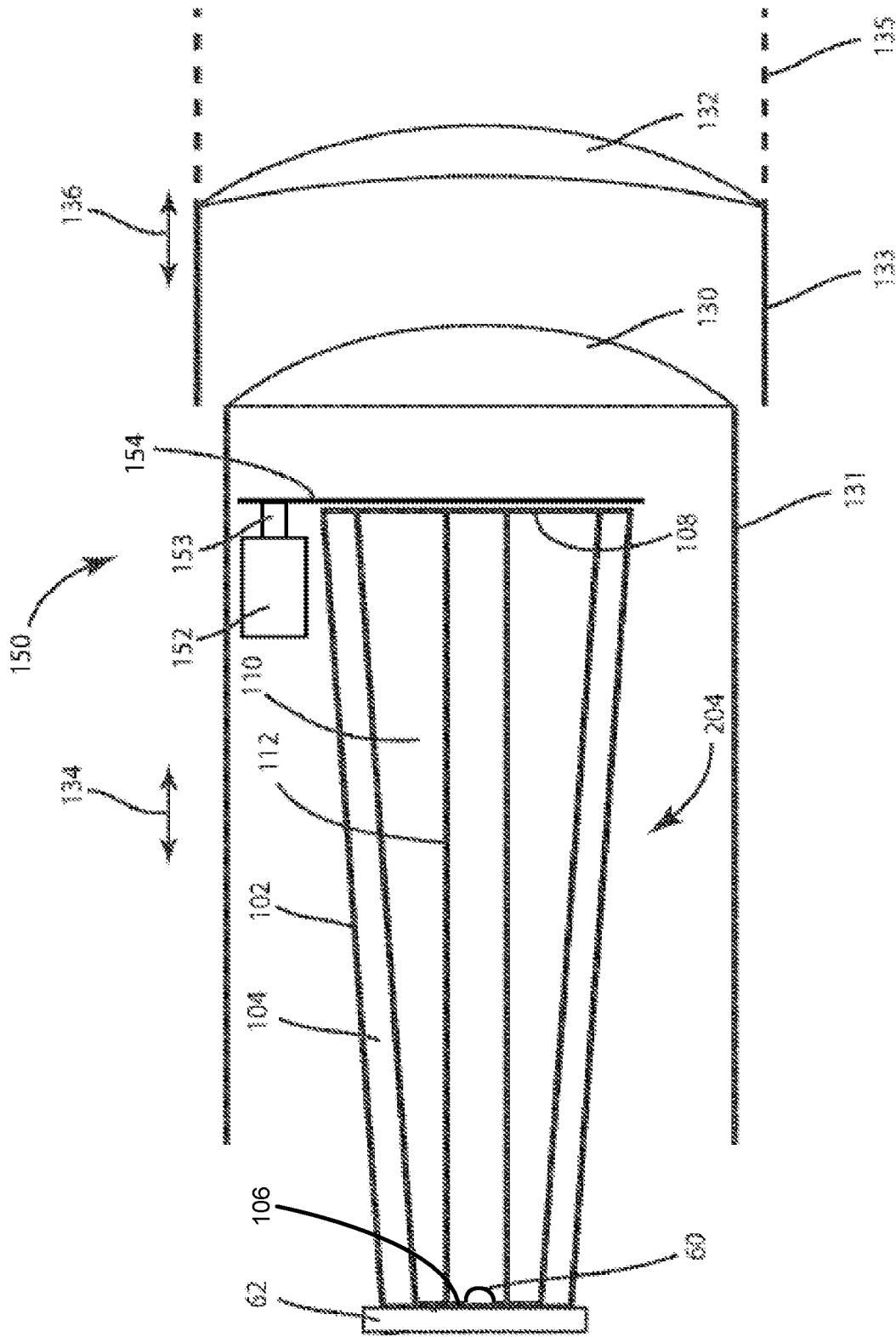

FIG 23

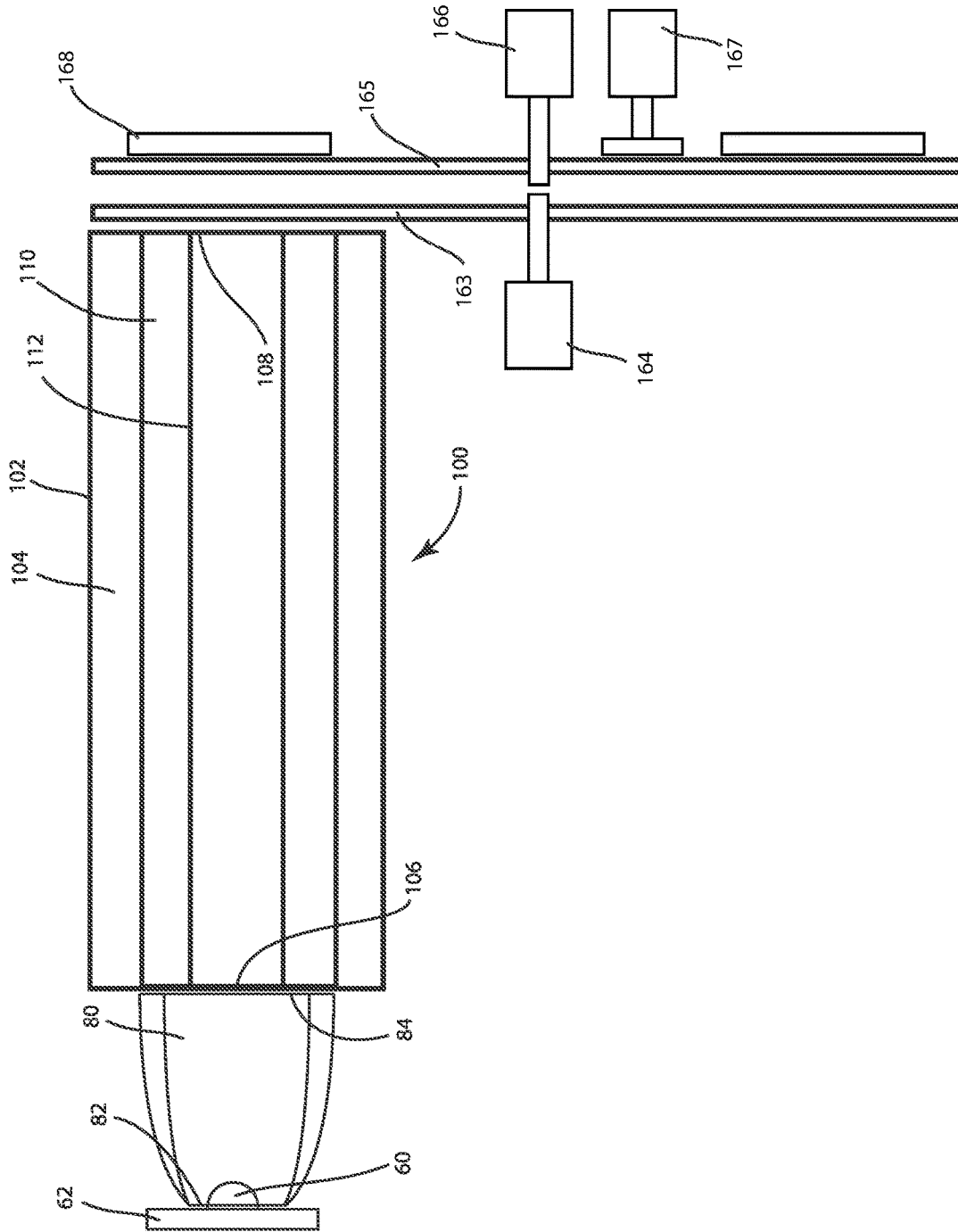

FIG 24



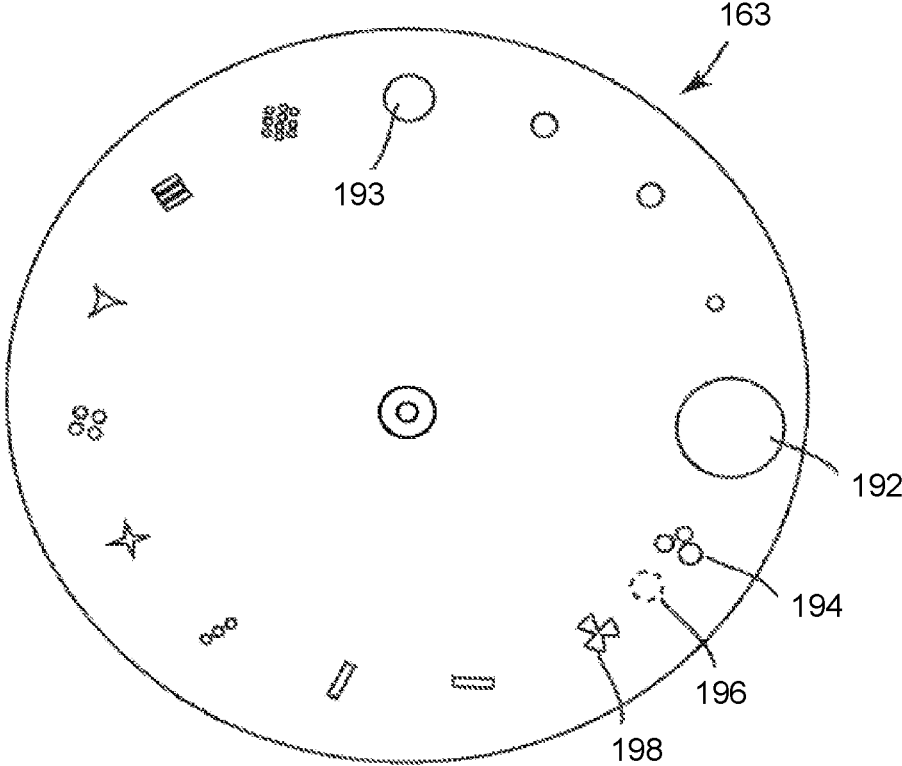

FIG 27

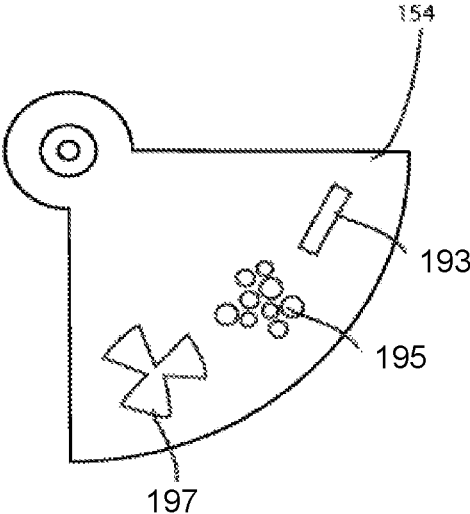

FIG 28

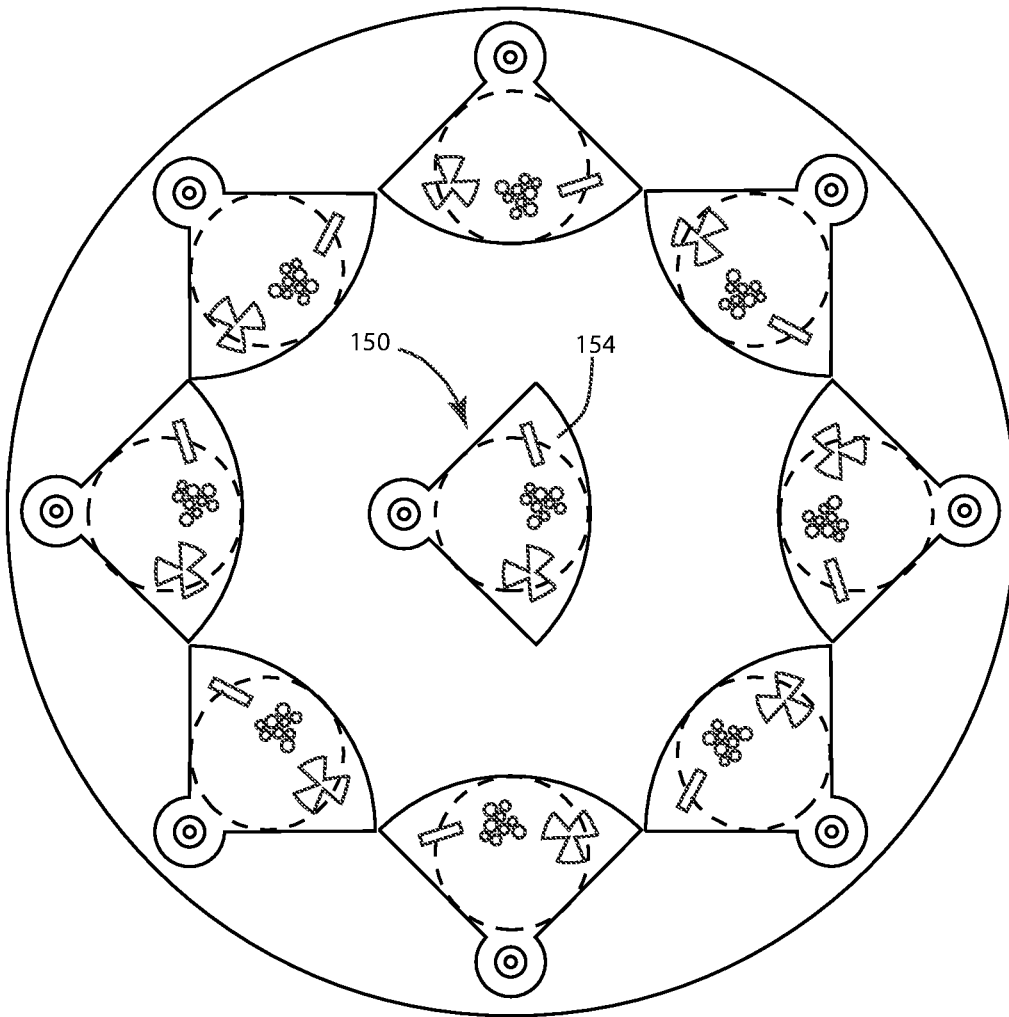
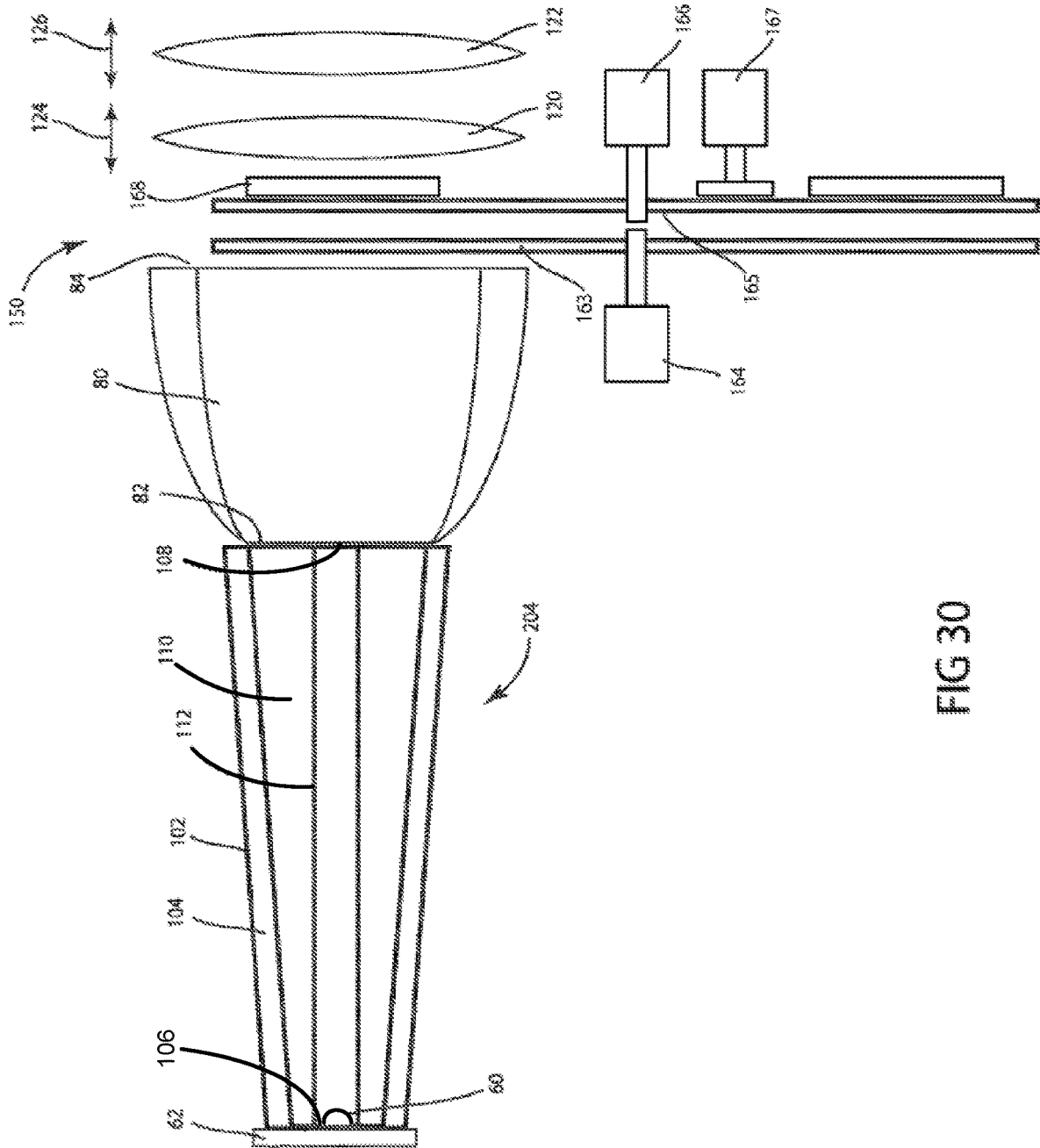

FIG 29





## COLLIMATION AND HOMOGENIZATION SYSTEM FOR AN LED LUMINAIRE

### CROSS-REFERENCE TO RELATED APPLICATIONS

This application is a filing under 35 U.S.C. § 371 of International Application No. PCT/US2014/058682 filed Oct. 1, 2014 entitled, "Collimation and Homogenization System for an LED Luminaire."

### TECHNICAL FIELD OF THE DISCLOSURE

The present disclosure generally relates to a method for controlling the light output from an array of light emitting diodes (LEDs) when used in a light beam producing luminaire, specifically to a method relating to improving the homogenization and collimation of the LEDs and for controlling the beam angle of the array.

### BACKGROUND OF THE DISCLOSURE

Luminaires with automated and remotely controllable functionality are well known in the entertainment and architectural lighting markets. Such products are commonly used in theatres, television studios, concerts, theme parks, night clubs, and other venues. A typical product will typically provide control over the pan and tilt functions of the luminaire, allowing the operator to control the direction the luminaire is pointing and thus the position of the light beam on the stage or in the studio. This position control is often done via control of the luminaire's position in two orthogonal rotational axes usually referred to as pan and tilt. Many products provide control over other parameters such as the intensity, color, focus, beam size, beam shape, and beam pattern. Additionally, it is becoming common to utilize high power LEDs as the light source in such luminaires and, for color control, it is common to use an array of LEDs of different colors. For example a common configuration is to use a mix of Red, Green and Blue LEDs. This configuration allows the user to create the color they desire by mixing appropriate levels of the three colors. For example illuminating the Red and Green LEDs while leaving the Blue extinguished will result in an output that appears Yellow. Similarly Red and Blue will result in Magenta and Blue and Green will result in Cyan. By judicious control of the LED controls the user may achieve any color they desire within the color gamut set by the LED colors in the array. More than three colors may also be used and it is well known to add an Amber or White LED to the Red, Green and Blue to enhance the color mixing and improve the gamut of colors available. The products manufactured by Robe Show Lighting such as the Robin 600 LEDWash are typical of the art.

The differently colored LED dies may be arranged on packages in the luminaire such that there is physical separation between each color of LED, and this separation, coupled with differences in die size for each color, may affect the spread of the individual colors and result in inadequate mixing of the different colors along with objectionable spill light and color fringing of the combined mixed color output beam. It is common to use a lens or other optical device in front of each LED package to control the beam shape and angle of the output beam; however, these optical devices may have differing effects for different colors and color fringing or other aberrations may be visible in the output beam. It would be advantageous to have a system where stray light and aberrations are well controlled.

FIG. 1 illustrates a prior art LED lighting system showing two LEDs in a package as may be used in a luminaire. LED 2 and LED 4 may be of differing colors and, due to the different optical properties and construction of the LEDs 2 and 4 produce light beams 6 and 8 that differ in beam spread. The differing beam spreads mean that the light beams from LEDs 2 and 4 will impinge on an illuminated object 18 in such a way that areas 20 and 16 of the object 18 are illuminated by a single LED only rather than the desired mix of both. This results in areas 20 and 16 being colored differently from the central mixed area and appearing as colored fringes. Only two (2) LEDs are illustrated in FIG. 1 for clarity and simplicity. It should be appreciated that the same problem exists with systems incorporating more than two colors of LEDs.

FIG. 2 illustrates a typical multiparameter automated LED luminaire system 10. These systems commonly include a plurality of multiparameter automated luminaires 12 which typically each contain on-board an array of LEDs, and electric motors coupled to mechanical drive systems and control electronics (not shown). In addition to being connected to mains power either directly or through a power distribution system (not shown), each automated luminaire 12 is connected in series or in parallel to data link 14 to one or more control desk(s) 15. The automated LED luminaire system 10 is typically controlled by an operator through the control desk 15. Consequently, to effect this control, both the control desk 15 and the individual luminaires 12 typically include electronic circuitry as part of the electromechanical control system for controlling the automated lighting parameters.

FIG. 3 and FIG. 4 illustrate an optical system used in the prior art to provide a variable beam angle or zoom to an automated LED luminaire. Each LED 50 which may be fitted with a primary optic 52 has an associated pair of lenses 53 and 55. Lenses 53 and 55 may be separate lenses or each part of an array of lenses covering the entire LED array. Lenses 53 and 55 may each comprise a single optical element 56 and 57 respectively. In operation at least one of lens 53 or lens 55 is stationary with respect to LED 50 while the other may move along optical axis 59. In the example illustrated in FIGS. 3 and 4, lens 55 is fixed relative to LED 50 while lens 53 is able to move along optical axis 59. FIG. 3 shows lens 53 in a first position and FIG. 4 shows lens 53 in a second position closer to LED 50. This varying relative position between LED 50, lens 53 and lens 55 provides a beam angle or zoom to the light beam from LED 50. Such systems are often limited in their zoom range by optical problems caused by the color separation and inadequate beam homogenization. They may further be limited by requiring large movements of the lenses.

There is a need for an optical system for an LED automated luminaire which provides improved color homogenization and beam collimation while also providing improved zoom range.

### BRIEF DESCRIPTION OF THE DRAWINGS

For a more complete understanding of the present disclosure and the advantages thereof, reference is now made to the following description taken in conjunction with the accompanying drawings in which like reference numerals indicate like features and wherein:

FIG. 1 illustrates a prior art LED lighting system;

FIG. 2 illustrates a typical multiparameter automated LED luminaire system;

3

FIG. 3 illustrates an optical system of a prior art LED luminaire;

FIG. 4 illustrates an optical system of a prior art LED luminaire;

FIG. 5 illustrates an embodiment of the optical system of the disclosure;

FIG. 6 illustrates an end view of the collimating and mixing optic and LED of FIG. 5;

FIG. 7 illustrates a front exit port view of the light integrator optic of FIG. 5;

FIG. 8 illustrates an optical system that is a further embodiment of the disclosure;

FIG. 9 illustrates an alternative embodiment of an optical system of the disclosure;

FIG. 10 illustrates an end view of the collimating and mixing optic of FIG. 9;

FIG. 11 illustrates a front view of the light integrator of FIG. 9;

FIG. 12 illustrates an optical system that is a further embodiment of the disclosure;

FIG. 13 illustrates an optical system that is a further alternative embodiment of an LED luminaire according to the disclosure;

FIG. 14 illustrates an optical system that is a further alternative embodiment of an LED luminaire according to the disclosure;

FIG. 15 illustrates an alternative embodiment of a portion of an LED luminaire according to the disclosure with a light spill reducing element;

FIG. 16 illustrates an embodiment of a layout of front optical elements of an LED luminaire according to the disclosure;

FIG. 17 illustrates a further alternative embodiment of a layout of front optical elements of an LED luminaire according to the disclosure;

FIG. 18 illustrates an embodiment of a light integrator optic of the disclosure;

FIG. 19 illustrates an alternative embodiment of a light integrator optic of the disclosure;

FIG. 20 illustrates an embodiment of a light integrator optic according to the disclosure, fitted with a gobo or pattern wheel;

FIG. 21 illustrates an alternative embodiment of a light integrator optic according to the disclosure, fitted with a gobo or pattern wheel;

FIG. 22 illustrates an alternative embodiment of a light integrator optic according to the disclosure fitted with a gobo or pattern wheel;

FIG. 23 illustrates an embodiment of a light integrator optic according to the disclosure, fitted with a gobo or pattern wheel;

FIG. 24 illustrates both a static gobo wheel and a full rotating gobo wheel as fitted to an embodiment of the disclosure;

FIG. 25 shows a full static gobo wheel in more detail in a further embodiment of the disclosure;

FIG. 26 shows a full rotating gobo wheel in more detail in a further embodiment of the disclosure;

FIG. 27 shows a full static gobo wheel in more detail in a further embodiment of the disclosure;

FIG. 28 illustrates an embodiment of a partial static gobo wheel;

FIG. 29 illustrates an embodiment of an array of light integrators of the disclosure, each fitted with a partial gobo wheel;

4

FIG. 30 illustrates an alternative embodiment of the disclosure, fitted with a full static gobo wheel and a full rotating gobo wheel; and

FIG. 31 illustrates a preferred embodiment of the disclosure fitted with a full static gobo wheel and a full rotating gobo wheel.

#### DETAILED DESCRIPTION OF THE DISCLOSURE

Preferred embodiments of the present disclosure are illustrated in the FIGURES, like numerals being used to refer to like and corresponding parts of the various drawings.

The present disclosure generally relates to a method for controlling the light output from an array of LEDs when used in a light beam producing luminaire, specifically to a method relating to improving the homogenization and collimation of the LEDs and for controlling the beam angle of the array.

Referring now to FIGS. 5, 6, and 7, FIG. 5 illustrates an embodiment of an optical system 100 of the disclosure. LED 60, which may include a primary optic, is mounted on substrate 62. LED 60 may contain a single color die or may contain multiple dies, each of which may be of differing colors. The light output from the dies in LED 60 enters collimating and mixing optic 80 at light entry port 82. Collimating and mixing optic 80 may be a solid optic using total internal reflection (TIR) to direct the light or may be a hollow reflective surface. Collimating and mixing optic 80 may have four sides 86, each of which may be curved with corners 92. The end view of collimating and mixing optic 80 in FIG. 6, combined with the side illustration of the collimating and mixing optic 80 in FIG. 5, illustrates details of an embodiment of the shape. The combination square sided shape with curved sides provides excellent mixing of the light from the dies 64 in LED 60. A further feature of collimating and mixing optic 80 is that it directs the reflected light to an external focal point which is comparatively close to its output port 84 of the collimating and mixing optic 80.

In the embodiment illustrated in FIG. 6 the configuration of the plurality of LED dies 64 in LED 60 is square and aligned with the sides 86 of the collimating and mixing optic 80. In other embodiments the alignment of the dies 64 with the sides 86 of collimating and mixing optic 80 may not be aligned, for example as illustrated in FIG. 10. In alternative embodiments of those illustrated in FIG. 6 and FIG. 10 the collimator may have three sides or more than four sides. In further embodiments the arrangement of the dies in the LED array may be configured in different shapes and paired with collimators with matching or divergent shapes.

In different embodiments, a degree of curvature of the sides 86 may vary—flatter for some configurations and more curved for other configurations. Additionally, the sharpness of the corners 92 between the sides 86 may vary among different collimators—sharper for some configurations and rounder for others. The selection of the number of sides and the curvature of the sides and curvature of the corners is/are tradeoffs between the degree of mixing desired and acceptable light loss for a particular configuration or application.

In the embodiment shown in FIG. 5, the reflected light exits collimating and mixing optic 80 at output port 84 and enters light integrator optic 102 at its entry port 106. Light integrator optic 102 is a device utilizing internal reflection so as to collect, homogenize, constrain, and conduct the light from collimating and mixing optic 80. Light integrator optic 102 may be a hollow tube with a reflective inner surface such that light impinging into the entry port 106 may be

reflected multiple times along the tube before leaving at the exit port **108**. Light integrator optic **102** may be a square tube, a hexagonal tube, a heptagonal tube, an octagonal tube, a circular tube, or a tube of any other cross section. In a further embodiment light integrator optic **102** may be a solid rod constructed of glass, transparent plastic or other optically transparent material where the reflection of the incident light beam within the rod is due to total internal reflection (TIR) from the interface between the material of the rod and the surrounding air. The integrating rod may be a square rod, a hexagonal rod, a heptagonal rod, an octagonal rod, a circular rod, or a rod of any other cross section. Embodiments of light integrator optics according to the disclosure with a polygonal cross section have reflective sides **110** and corners **112** between the reflective sides as seen in FIG. **5**, which includes a side cross sectional view of the light integrator optic **102** and more easily seen in FIG. **7**, a front exit port **108** view of the light integrator optic **102**.

In a yet further embodiment the light integrator optic **102** may have a straight sided square cross section at the entry port **106** and a straight sided polygonal cross section with more than four sides at the exit port **108**. The exit port **108** may be pentagonal, hexagonal, heptagonal, octagonal, or have any other integral number of sides.

A feature of a light integrator optic **102**, which comprises a hollow tube or solid rod where the sides of the rod or tube are essentially parallel and the entry port **106** and exit port **108** are of the same size, is the divergence angle of light exiting the light integrator optic **102** at exit port **108** will be the same as the divergence angle for light entering the light integrator optic **102** at entry port **106**. Thus, a parallel sided light integrator optic **102** has no effect on the beam divergence and will transfer the position of the focal point of collimating and mixing optic **80** at its output port **84** to the light integrator optic's **102** exit port **108**. The light exiting light integrator optic **102** will be well homogenized with all the colors of LED **60** mixed together into a single colored light beam and may be used as our output, or may be further modified by downstream optical systems.

Light integrator optic **102** may advantageously have an aspect ratio where its length is much greater than its diameter. The greater the ratio between length and diameter, the better the resultant mixing and homogenization will be. Light integrator optic **102** may be enclosed in a tube or protective sleeve **104** which provides mechanical protection against damage, scratches, and dust.

FIG. **8** illustrates an optical system **101** that is a further embodiment of the disclosure. Elements LED **60**, substrate **62**, collimating and mixing optic **80**, and light integrator optic **102**, are as described above for FIG. **5**, FIG. **6**, and FIG. **7**. In this embodiment, the homogenized and focused light exiting from light integrator optic **102** is directed through a lens system comprising lenses **120** and **122**. Lenses **120** and **122** may be independently movable, as shown by arrows **124** and **126**, along the optical axis so as to provide beam angle control over the light beam. Because the focal point of collimating and mixing optic **80** is short, a small motion of lenses **120** and **122** may cause a large change in beam angle. In one embodiment, movements of 10 mm in the position of lenses **120** and/or **122** may cause a change in beam angle from 5° to 50°. Thus providing an improved variable beam angle or zoom to an automated LED luminaire.

In further embodiments, lenses **120** and **122** may form an achromatic optical system such that it provides the same degree of beam angle change to long wavelength red light as it does to short wavelength blue light and thus avoids

chromatic aberration. This ensures that the beams from the different colors of LED dies **64** in LED **60** are all the same size resulting in a uniformly colored combined beam. In yet further embodiments, any number of lenses may be used as the lens system. In all cases, lenses may contain one or more optical elements. Lenses **120** and **122** are illustrated herein as bi-convex lenses however the disclosure is not so limited and lenses **120** and **122** may be any shaped optical element as well known in the art.

Referring now to FIGS. **9-11**, FIG. **9** illustrates an embodiment (system **200**) of the optical system of the disclosure. LED **60**, which may include a primary optic, is mounted on substrate **62**. LED **60** may contain a single color die **64** or may contain multiple dies **64**, each of which may be of differing colors. The light output from the dies **64** in LED **60** enters light integrator optic **102** at entry port **106**. Light integrator optic **102** may be of the same construction and configuration as in the embodiment illustrated in FIG. **5**. Light integrator optic **102** is a device utilizing internal reflection so as to collect, homogenize and constrain, and conduct the light to the entry port **82** of collimating and mixing optic **80**. Light integrator optic **102** may be a hollow tube with a reflective inner surface such that light impinging into the entry port **106** may be reflected multiple times along the tube before leaving at the exit port **108**. Light integrator optic **102** may be a square tube, a hexagonal tube, a heptagonal tube, an octagonal tube, a circular tube, or a tube of any other cross section. In a further embodiment light integrator optic **102** may be a solid rod constructed of glass, transparent plastic, or other optically transparent material where the reflection of the incident light beam within the rod is due to total internal reflection (TIR) from the interface between the material of the rod and the surrounding air. The integrating rod may be a square rod, a hexagonal rod, a heptagonal rod, an octagonal rod, a circular rod, or a rod of any other cross section. FIG. **11** illustrates a front view of the light integrator optic **102** of FIG. **9**.

A feature of a light integrator optic **102** which comprises a hollow tube or solid rod where the sides of the rod or tube are essentially parallel and the entry port **106** and exit port **108** are of the same size is that the divergence angle of light exiting the light integrator optic **102** at exit port **108** will be the same as the divergence angle for light entering the light integrator optic **102** at entry port **106** from LED **60**. Thus a parallel sided light integrator optic **102** has no effect on the beam divergence and will transfer the light from LED **60** to its exit port **108**. The light exiting light integrator optic **102** will be well homogenized with all the colors of LED **60** mixed together into a single colored light beam.

Light integrator optic **102** may advantageously have an aspect ratio where its length is much greater than its diameter. The greater the ratio between length and diameter, the better the resultant mixing and homogenization will be. Light integrator optic **102** may be enclosed in a tube or protective sleeve **104** which provides mechanical protection against damage, scratches, and dust.

Light exiting light integrator optic **102** at exit port **108** enters collimating and mixing optic **80** at its entry port **82**. Collimating and mixing optic **80** may be of the same construction and configuration as the collimating and mixing optic in the embodiment illustrated in FIG. **5**. Collimating and mixing optic **80** may be a solid optic using total internal reflection (TIR) to direct the light or may be a hollow reflective surface. Collimating and mixing optic **80** may have four sides, each of which may be curved. The side view of collimating and mixing optic **80** included in FIG. **9** and the end view of collimating and mixing optic **80** in FIG.

10 illustrate the detail of this shape. The combination square sided shape with curved sides provides further mixing of the light from the dies 64 in LED 60 as homogenized by light integrator optic 102. A further feature of collimating and mixing optic 80 is that it directs the reflected light to an external focal point which is comparatively close to its output port 84.

In the embodiment shown in FIG. 9 the reflected light exits collimating and mixing optic 80 at output port 84 and may be used as our output, or may be further modified by downstream optical systems.

FIG. 12 illustrates a further embodiment (system 202) of the disclosure. Elements LED 60, substrate 62, collimating and mixing optic 80, and light integrator of 102, can be as described above. In this embodiment the homogenized and focused light exiting from collimating and mixing optic 80 is directed through a lens system comprising lenses 120 and 122. Lenses 120 and 122 may be independently movable along the optical axis so as to provide beam angle control over the exiting light beam. Because the focal point of collimating and mixing optic 80 is short, a small motion of lenses 120 and 122 may cause a large change in beam angle. In one embodiment, a movement of 10 mm in the position of lenses 120 and/or 122 may cause a change in beam angle from 5° to 50°. Thus providing an improved variable beam angle or zoom to an automated LED luminaire.

In further embodiments, lenses 120 and 122 may form an achromatic optical system such that it provides the same degree of beam angle change to long wavelength red light as it does to short wavelength blue light and thus avoids chromatic aberration. This ensures that the beams from the different colors of LED dies 64 in LED 60 are all the same size resulting in a uniformly colored combined beam. In yet further embodiments any number of lenses may be used as the lens system. In all cases, lenses may contain one or more optical elements. Lenses 120 and 122 are illustrated herein as bi-convex lenses however the disclosure is not so limited and lenses 120 and 122 may be any shaped optical element as well known in the art and may include any number of lenses including a single lens. This applies to any of the embodiments discussed above

FIG. 13 and FIG. 14 illustrate further alternative embodiments (systems 103 and 204, respectively) of LED luminaires according to the disclosure. In both of these embodiments the light integrator optic 102, whether solid or hollow, has sides 110 which are tapered so that entry port 106 is smaller than the exit port 108. The advantage of this structure is that the divergence angle of light exiting the light integrator optic 102 at exit port 108 will be smaller than the divergence angle for light entering the light integrator optic 102 at entry port 106. The combination of a smaller divergence angle from a larger aperture serves to conserve the etendue of the system. Thus, the tapered light integrator optic 102 may provide similar functionality to a condensing optical system. Therefore, some embodiments may not include lenses 120 and 122 as discussed above while other embodiments may include such elements as discussed above with regard to embodiments with non-tapered integrators.

FIG. 15 illustrates a further alternative embodiment of a portion 302 of an LED luminaire with the optical system 204 having a light spill reducing element. In this embodiment the light integrator optic 102, whether solid or hollow, and with any number of sides, or with a square entry port 106 and a polygonal exit port 108 has sides 110 which are tapered so that entry port 106 is smaller than the exit port 108. The advantage of this structure is that the divergence angle of light exiting the light integrator optic 102 at exit port 108

will be smaller than the divergence angle for light entering the light integrator optic 102 at entry port 106. The combination of a smaller divergence angle from a larger aperture serves to conserve the etendue of the system. Thus a tapered light integrator optic 102 may provide similar functionality to a condensing optical system. Therefore, some embodiments may not include lenses 120 and 122 as discussed above while other embodiments may include such elements as discussed above with regard to embodiments with non-tapered integrators. Additionally, this embodiment may alternately utilize lenses 130 and 132 as optical elements providing condensing, beam angle control, and focusing functionality as described above as a replacement for the collimating and mixing optic 80 used in earlier embodiments. Lenses 130 and 132 may be meniscus lenses, plano-convex lenses, bi-convex lenses, or other lenses as well known in the art. In the embodiment illustrated, lens 130 is a plano-convex lens and lens 132 is a meniscus lens.

FIG. 15 also shows optional spill reducing elements 131 and 133. Spill reducing elements 131 and 133 may comprise hollow opaque thin walled tubes which are attached to, and move with, lenses 130 and 132 respectively. These tubes reduce light spill from the exit port 108 which may impinge on adjacent light integrators and their associated optical systems. Spill reducing element 131 may be of a smaller diameter than spill reducing element 133 such that lens 130 and its attached spill reducing element 131 may move within spill reducing element 133 such that lenses 130 and 132 may move to be adjacent. An external further additional spill reducing element 135 may also be added to and may move with lens 132. Lens 130 may be moved as shown by arrow 134, and lens 132 may be moved as shown by arrow 136. Such movement allows changing the focal length, and thus the beam angle of the output light beam. Lenses 130 and 132 may move together as a pair with a single actuator, or, in a further embodiment, may move independently each with its own actuator.

FIG. 16 shows an embodiment of a layout 160 of front optical elements of the LED luminaire 302. In FIG. 15, there is a front lens 132 which forms the final output lens of the system. FIG. 16 shows a front view of four of the systems 204 shown in FIG. 15 mounted in a square array. In this embodiment the four optical elements 162, 164, 166, and 168 in FIG. 16 each represent an identical example of lens 132 in FIG. 15. Optical element 162 is constructed as part of a larger, quadrant shaped, structure 172. Structure 172 incorporating optical element 162 may be molded from a single piece of glass or optical plastic. Similarly optical element 164 is incorporated as part of quadrant shaped structure 174, optical element 166 is incorporated as part of quadrant shaped structure 176, and optical element 168 is incorporated as part of quadrant shaped structure 178. The incorporation of the optical elements into quadrants provides two desirable results. Firstly, four modules may be placed in a square array while representing an unbroken and clean appearance from the front with the four quadrants joining to provide a complete circle. Secondly, any remaining spill light from the optical modules will disperse and dissipate within the areas of the quadrants outside the optical elements, providing an attractive light glow between the optical elements.

FIG. 17 shows a further alternative embodiment of a layout 170 of front optical elements of the LED system 302. In, for example FIG. 15, there is a front lens 132 which forms the final output lens of the system. FIG. 16 shows a front view of four of the systems 204 shown in FIG. 15 mounted in a square array. In this embodiment the four

optical elements **182**, **184**, **186**, and **188** in FIG. **17** each represent an identical example of lens **132** in FIG. **15** molded into a quadrant shape. The configuration of the optical elements as quadrants provides two desirable results. Firstly, four modules may be placed in a square array while representing an unbroken and clean appearance from the front with the four quadrants joining to provide a complete circle. Secondly, any remaining spill light from the optical modules will disperse and dissipate within the areas of the quadrants outside the optical elements, providing an attractive light glow between the optical elements.

FIG. **18** illustrates an embodiment of the light integrator optic **102a** of the disclosure. In this embodiment entry port **106a** is square in cross-section and exit port **108a** is hexagonal in cross-section.

FIG. **19** illustrates an alternative embodiment of the light integrator optic **102b** of the disclosure. In this embodiment, entry port **106b** is square in cross-section and exit port **108b** is octagonal in cross-section.

In the alternative embodiments illustrated in FIGS. **20**, **21**, **22**, and **23** the optical system is further fitted with a gobo wheel system **150**. A gobo wheel contains patterns or images that will controllably mask the light exiting through output port **84**. These images will then be projected by downstream optical elements to create a pattern projecting light beam. The lens system after the gobo wheel may be a zoom lens system such as shown in FIG. **20** by lenses **120** and **122** or any other projecting lens system as well known in the art. Gobo wheel **154** may be rotated through motor **152** and shaft **153** in order to select different gobo patterns in front of output port **84**. Gobo wheel system **150** may incorporate a static gobo wheel, a rotating gobo wheel, or both. The static gobo wheel or rotating gobo wheel may each be a full wheel, or a partial wheel.

FIG. **24** illustrates both a full static gobo wheel and a full rotating gobo wheel as fitted to an embodiment of the disclosure. Gobo wheel **163** may be rotated through motor **164** in order to select different gobo patterns in front of exit port **108**. In yet further embodiments individual gobo patterns may be further rotated about their axes by supplementary motors in order to provide a moving rotating image. Such rotating gobo wheels are well known in the art. Rotating gobo wheel **165** is an example of such an embodiment. Rotating gobo wheel **165** may be rotated through motor **166** in order to select different gobo patterns **168** in front of exit port **108**. Gobo patterns **168** may then be rotated about the optical axis of the system through motor **167**.

FIG. **25** shows gobo wheel **163** in more detail in a further embodiment of the disclosure. Gobo wheel **163** contains a plurality of patterns including, for example, **192**, **193**, **194**, **196**, and **198** that may be moved across and in front of the exit port of the light integrator by rotation about motor **164**. FIG. **26** shows rotating gobo wheel **165** in more detail in a further embodiment of the disclosure. Gobo wheel **165** contains a plurality of patterns including, for example, a pattern **191** that may be moved across and in front of the exit port of the light integrator by rotation about motor **166**. These gobo patterns may then be rotated about the optical axis of the system through motor **167**. FIG. **27** shows gobo wheel **163** in more detail in a further embodiment of the disclosure. Gobo wheel **163** contains a plurality of patterns including, for example, **192**, **193**, **194**, **196**, and **198** that may be moved across and in front of the exit port of the light integrator by rotation about motor **164**.

In further embodiments the gobo wheel may not be a complete circular disc as shown in FIG. **27**, but may be a portion of a disc, or a flag so as to save space and provide

a more limited number of gobo options. FIG. **28** illustrates an embodiment of a partial static gobo wheel where gobo wheel **154**, which is a quadrant of a circle containing three gobo patterns, **193**, **195**, and **197**. Such an arrangement with partial wheel **154** facilitates embodiments such as that illustrated in FIG. **29** where multiple light integrators are utilized in a single luminaire. Each of those light integrators may be fitted with an independent gobo system **150** comprising a partial gobo wheel **154**, all or any of which may be individually or cooperatively controlled. Utilizing partial gobo wheels **154** may allow a tighter packing density for the light integrators and optical systems without interference between the adjacent wheels. In the example illustrated, nine light integrators and associated gobo systems **150** are utilized in a circular arrangement. However, the disclosure is not so limited and any number of light integrators in any arrangement may be utilized without departing from the spirit of the disclosure. Additionally, it is not necessary that every light integrator is fitted with a gobo system; embodiments may be constructed where a proportion of the light integrators are fitted with gobo systems, and a proportion are not.

FIG. **30** illustrates both a full static gobo wheel and a full rotating gobo wheel as fitted as gobo wheel system **150** in an alternative embodiment of the disclosure. Gobo wheel **163** may be rotated through motor **164** in order to select different gobo patterns in front of output port **84**. In yet further embodiments, individual gobo patterns may be further rotated about their axes by supplementary motors in order to provide a moving rotating image. Such rotating gobo wheels are well known in the art. Rotating gobo wheel, **165**, is an example of such an embodiment. Rotating gobo wheel **165** may be rotated through motor **166** in order to select different gobo patterns **168** in front of output port **84**. Gobo patterns **168** may then be rotated about the optical axis of the system through motor **167**.

FIG. **31** illustrates both a full static gobo wheel and a full rotating gobo wheel as fitted as gobo wheel system **150** in a preferred embodiment of the disclosure. Gobo wheel **163** may be rotated through motor **164** in order to select different gobo patterns in front of exit port **108**. In yet further embodiments individual gobo patterns may be further rotated about their axes by supplementary motors in order to provide a moving rotating image. Such rotating gobo wheels are well known in the art. Rotating gobo wheel, **165**, is an example of such an embodiment. Rotating gobo wheel **165** may be rotated through motor **166** in order to select different gobo patterns **168** in front of exit aperture **108**. Gobo patterns **168** may then be rotated about the optical axis of the system through motor **167**.

In all embodiments both the static and rotating gobo patterns may be of any shape and may include colored images or transparencies. Additionally effects such as prisms, lenticular lenses, or break up glasses may be used without departing from the spirit of the disclosure. For example, the use of a lenticular lens may provide an elliptical beam from each light integrator and rotating that lenticular lens may rotate the elliptical beam about its optical axis. Cooperatively or independently rotating such lenticular lenses on a luminaire with multiple light integrators such as that illustrated in FIG. **29**, may provide new dynamic lighting effects for the operator.

While the disclosure has been described with respect to a limited number of embodiments, those skilled in the art, having benefit of this disclosure, will appreciate that other embodiments may be devised which do not depart from the scope of the disclosure as disclosed herein. The disclosure

11

has been described in detail, it should be understood that various changes, substitutions and alterations can be made hereto without departing from the spirit and scope of the disclosure.

What is claimed is:

1. An automated luminaire, comprising:
  - a plurality of light sources, each light source comprising:
    - a plurality of light emitting diode (LED) sources, each LED source configured to emit a different color of light; and
    - a light integrator optically coupled to the plurality of LED sources and configured to homogenize the colors of light emitted by the LED sources;
  - a plurality of receiving lens assemblies, each receiving lens assembly optically coupled to an associated one of the plurality of light sources, each receiving lens assembly comprising a receiving lens and a receiving lens spill shield, the receiving lens spill shield extending (i) toward the associated one of the plurality of light sources, (ii) parallel to a light source optical axis of the associated one of the plurality of light sources, and (iii) around at least a portion of the light integrator and mechanically coupled to the receiving lens, each receiving lens spill shield configured to reduce light spill from between the light integrator of the associated one of the plurality of light sources and the receiving lens impinging on a receiving lens or other optical component associated with an adjacent light integrator;
  - an output lens assembly optically coupled to the plurality of receiving lens assemblies, the output lens assembly comprising an output lens and an output lens spill shield, the output lens spill shield extending around at least a portion of at least one receiving lens assembly and configured to move with the output lens, the output lens spill shield configured to reduce light spill from the at least one receiving lens assembly impinging on optical components associated with an adjacent receiving lens assembly; and
  - a gobo carrier optically coupled to at least one light source of the plurality of light sources and to the associated one of the plurality of receiving lens assemblies, the receiving lens spill shield extending around at least a portion of the gobo carrier, the gobo carrier comprising a plurality of gobo patterns, the gobo carrier configured to be electrically actuated to move a selected one of the plurality of gobo patterns into a light beam emitted from the at least one light source, the receiving lens assembly associated with the gobo carrier is configured to move along the light source optical axis of the associated one of the plurality of light sources, the output lens assembly is configured to move along an optical axis of the plurality of receiving lens assemblies, and the receiving lens assembly associated with the gobo carrier is configured to move independently of the output lens assembly.
2. The automated luminaire of claim 1, wherein at least one light integrator comprises an input port having a square cross section and an output port having a hexagonal cross section.
3. The automated luminaire of claim 1, wherein the light integrator comprises a solid rod where reflection within the solid rod of light emitted by the LED sources is due to total internal reflection (TIR).
4. The automated luminaire of claim 1, wherein the light integrator comprises an input port and an output port, the

12

input port having a smaller size than the output port, the light integrator tapering in size from the input port to the output port.

5. The automated luminaire of claim 1, wherein the gobo carrier comprises a portion of a disc.
6. The automated luminaire of claim 1, wherein the gobo carrier is a first gobo carrier, the automated luminaire further comprising a second gobo carrier optically coupled to the first gobo carrier and to the receiving lens assembly, the receiving lens spill shield extending around at least a portion of the second gobo carrier, and the first gobo carrier comprising static gobo patterns and the second gobo carrier comprising rotating gobo patterns.
7. The automated luminaire of claim 1, comprising a plurality of output lens assemblies corresponding to the plurality of light sources, wherein the plurality of output lens assemblies comprise a single optical element.
8. The automated luminaire of claim 1, comprising a plurality of gobo carriers corresponding to the plurality of light sources, wherein at least one gobo carrier of the plurality of gobo carriers is configured to be electrically actuated independently from the other gobo carriers.
9. The automated luminaire of claim 1, further comprising electronic circuitry configured to individually control the brightness of each of the plurality of LED sources.
10. The automated luminaire of claim 1, further comprising electronic circuitry configured to individually move the selected one of the plurality of gobo patterns into a light beam, move the receiving lens assembly associated with the gobo carrier along the light source optical axis of the associated one of the plurality of light sources, and move the output lens assembly along the optical axis of the plurality of receiving lens assemblies.
11. The automated luminaire of claim 10, further comprising first and second electromechanical drive systems configured to rotate the automated luminaire about corresponding first and second orthogonal axes, wherein the electronic circuitry is configured to operate the first and second electromechanical drive systems in response to signals received via a data link.
12. An automated luminaire, comprising:
  - a plurality of light sources, each light source comprising:
    - a plurality of light emitting diode (LED) sources, each LED source configured to emit a different color of light; and
    - a light integrator optically coupled to the plurality of LED sources and configured to homogenize the colors of light emitted by the LED sources;
  - a gobo carrier optically coupled to the plurality of light sources, wherein the gobo carrier comprises a plurality of gobo wheels, the number of gobo wheels being less than or equal to the number of light sources, each of the plurality of gobo wheels being optically coupled to an associated one of the plurality of light sources, the gobo carrier configured to move at least one of the plurality of gobo wheels into a light beam emitted from the associated one of the plurality of light sources;
  - a plurality of receiving lens assemblies, each receiving lens assembly optically coupled via the gobo carrier to an associated one of the plurality of light sources, each receiving lens assembly comprising a receiving lens and a receiving lens spill shield, the receiving lens spill shield mechanically coupled to the receiving lens and extending (i) toward the associated one of the plurality of light sources, (ii) parallel to a light source optical axis of the associated one of the plurality of light

13

sources, and (iii) around at least a portion of the gobo carrier and the light integrator of the associated one of the plurality of light sources, each receiving lens spill shield configured to reduce light spill from between the light integrator of the associated one of the plurality of light sources and the receiving lens impinging on a receiving lens or other optical component associated with an adjacent light integrator; and

a plurality of output lens assemblies, each output lens assembly optically coupled to an associated one of the plurality of receiving lens assemblies, each output lens assembly comprising an output lens and an output lens spill shield mechanically coupled to the output lens, the output lens spill shield extending around at least a portion of the associated one of the plurality of receiving lens assemblies,

each of the plurality of receiving lens assemblies is configured to move along the light source optical axis of the associated one of the plurality of light sources, and each of the plurality of output lens assemblies is configured move along an optical axis of the associated one of the plurality of receiving lens assemblies, the receiving lens assemblies configured to move independently of the output lens assemblies.

13. The automated luminaire of claim 12, wherein at least one light integrator of the plurality of light sources comprises an input port having a square cross section and an output port having a hexagonal cross section.

14. The automated luminaire of claim 12, wherein at least one light integrator of the plurality of light sources com-

14

prises a solid rod where reflection within the solid rod of light emitted by the LED sources is due to total internal reflection (TIR).

15. The automated luminaire of claim 12, wherein at least one light integrator of the plurality of light sources comprises an input port and an output port, the input port having a smaller size than the output port, and the light integrator tapering in size from the input port to the output port.

16. The automated luminaire of claim 12, wherein at least one gobo wheel of the plurality of gobo wheels comprises a portion of a disc.

17. The automated luminaire of claim 12, wherein optical axes of the plurality of light sources are parallel, and wherein the plurality of output lens assemblies comprise a single optical element, and wherein the single optical element is configured to move in a direction parallel to the optical axes of the plurality of light sources.

18. The automated luminaire of claim 12, further comprising electronic circuitry configured to individually control the brightness of each of the plurality of LED sources in at least one of the plurality of light sources.

19. The automated luminaire of claim 12, further comprising electronic circuitry configured to individually move the at least one of the plurality of gobo wheels, the plurality of receiving lens assemblies along the light source optical axes of the associated ones of the plurality of light sources, and the plurality of output lens assemblies along the receiving lens optical axes of the associated ones of the plurality of receiving lens assemblies.

\* \* \* \* \*